



- IT** Ponte sollevatore elettroidraulico a forbice ideale per gommisti, carrozzerie e garage.  
**EN** Electro-hydraulic scissor lift suitable for tyre shops, body shops and workshops.  
**FR** Pont élévateur électrohydraulique à ciseaux pour le service pneus, carrosserie et garages.  
**DE** Elektrohydraulische Scherenhebebühne für Reifenhändler, Karosserie und Reparaturwerkstätten.  
**ES** Elevador de tijera electrohidráulico ideal para servicios de neumáticos, chapisterías y talleres.



- IT** Minimo ingombro a ponte chiuso.  
**EN** Minimal size for lift in lowest position.  
**FR** Encombrement minimale à pont fermé.  
**DE** Minimaler Raumbedarf in der geschlossenen Position.  
**ES** Dimensiones mínimas todo cerrado.

**Caratteristiche • Features • Fonctions • Funktionen • Funciones**



**IT** Centralina di comando mobile, coperta. Comandi “Uomo presente”.  
**EN** Portable control unit, covered. “Dead man” controls.  
**FR** Unité de commande mobile, couverte. Commandes de type “Homme mort”.  
**DE** Tragbare Steuerheit, überdachte. Steuerungen „Bedienerpräsenz”.  
**ES** Unidad de mando móvil, cubierta. Mandos “Hombre muerto”.



**IT** Struttura robusta.  
**EN** Strong frame.  
**FR** Structure solide.  
**DE** Robuste Struktur.  
**ES** Estructura robusta.



**IT** 2 mt. di tubi flessibili di collegamento pont-centralina **EN** 2 mt. flexible hoses between lift and control unit **FR** 2 mt. de tuyaux flexibles de connections entre pont et pupitre **DE** 2 mt. Verbindungsschlauch Hebebühne/Steuereinheit **ES** 2 mt. de tubos flexibles de conexión elevador-unidad de control.

**IT** Pattini di scorrimento in materiale plastico autolubrificanti  
**EN** Self-lubricating plastic sliders **FR** Patins en matière plastique autolubrifiants **DE** Selbstschmierende Gleitböcke aus Kunststoff **ES** Patines de deslizamiento de material plástico autolubricantes.

**IT** Perni con boccole autolubrificanti.  
**EN** Pins with self-lubricating bushes.  
**FR** Axes avec bagues autolubrifiant.  
**DE** Bolzen mit selbstschmierenden Buchsen.  
**ES** Pernos con casquillos autolubricantes.

**IT** Sincronizzazione meccanica con doppia barra di torsione  
**EN** Mechanical synchronization with double torsion bar **FR** Synchronisation mécanique avec une double barre de torsion **DE** Mechanischer Gleichlauf mit doppeltem Torsionsstab **ES** Sincronización mecánica con doble barra de torsión.



**IT** Sicurezza meccanica a comando elettrico.  
**EN** Mechanical safety with electric control.  
**FR** Sécurité mécanique à commande électrique.  
**DE** Mechanische Sicherheitsvorrichtung mit elektrischer Steuerung.  
**ES** Seguridad mecánica de mando eléctrico.

**IT** Valvola controllo velocità di discesa.  
**EN** Safety valves to check the descent speed.  
**FR** Soupape de sécurité pour le contrôle vitesse de descente.  
**DE** Ventil zur Kontrolle der Senkgeschwindigkeit.  
**ES** Válvula de control de la velocidad de descenso.

**IT** Valvola di sovraccarico.  
**EN** Overload valve.  
**FR** Vanne de surcharge.  
**DE** Überdruckventil.  
**ES** Válvula de sobrecarga.

**IT** Segnale acustico in fase finale della discesa.  
**EN** Acoustic signal during the final lowering phase.  
**FR** Signal sonore d'avertissement dans la phase finale de la descente.  
**DE** Akustisches Signal in Endphase der Senkung.  
**ES** Señal acústica durante el momento final de descenso.

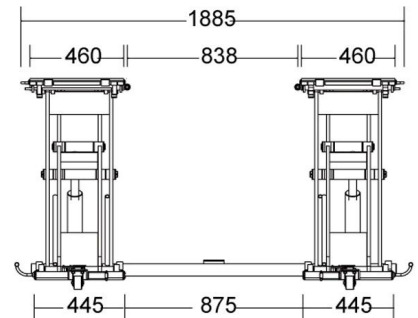
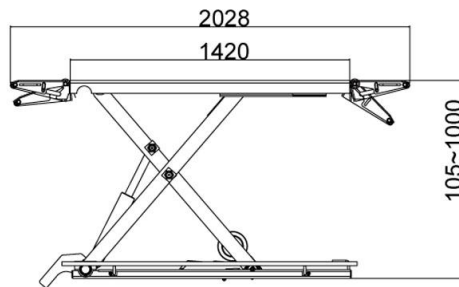
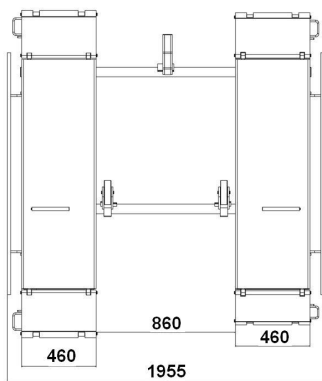
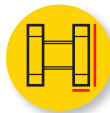

**Dati tecnici • Technical data • Données techniques • Technisches Daten • Datos técnicos**

<ul style="list-style-type: none"> <li>• Portata massima</li> <li>• Capacity</li> <li>• Capacité de charge</li> <li>• Tragfähigkeit</li> <li>• Capacidad</li> </ul>	<ul style="list-style-type: none"> <li>• Altezza max</li> <li>• Maximum height</li> <li>• Hauteur maxi</li> <li>• Maximalhöhe</li> <li>• Altura máxima</li> </ul>	<ul style="list-style-type: none"> <li>• Altezza min</li> <li>• Minimum height</li> <li>• Hauteur minimum</li> <li>• Minimalhöhe</li> <li>• Altura mínima</li> </ul>	<ul style="list-style-type: none"> <li>• Alimentazione</li> <li>• Power supply</li> <li>• Alimentation</li> <li>• Stromversorgung</li> <li>• Alimentación</li> </ul>	<ul style="list-style-type: none"> <li>• Tempo di sollevamento</li> <li>• Lifting time</li> <li>• Temps de soulèvement</li> <li>• Heben Zeit</li> <li>• Tiempo de elevación</li> </ul>	<ul style="list-style-type: none"> <li>• Peso netto</li> <li>• Net weight</li> <li>• Poids net</li> <li>• Nettogewicht</li> <li>• Peso neto</li> </ul>
3000 Kg	1000 mm	110 mm	230/400V 50Hz 3ph 230V 50Hz 1ph	30 sec	500 Kg