

FORBIKES

S.R.L.

COMPONENTI PER MOTOCICLI

|| CATALOGO 2022



ASIDEROS PARA MOTOS DEPORTIVAS



QUICK RELEASE MOTORCYCLE TURN INDICATORS

DAYTONA



FK VISORS
THE VISORS SPECIALISTS

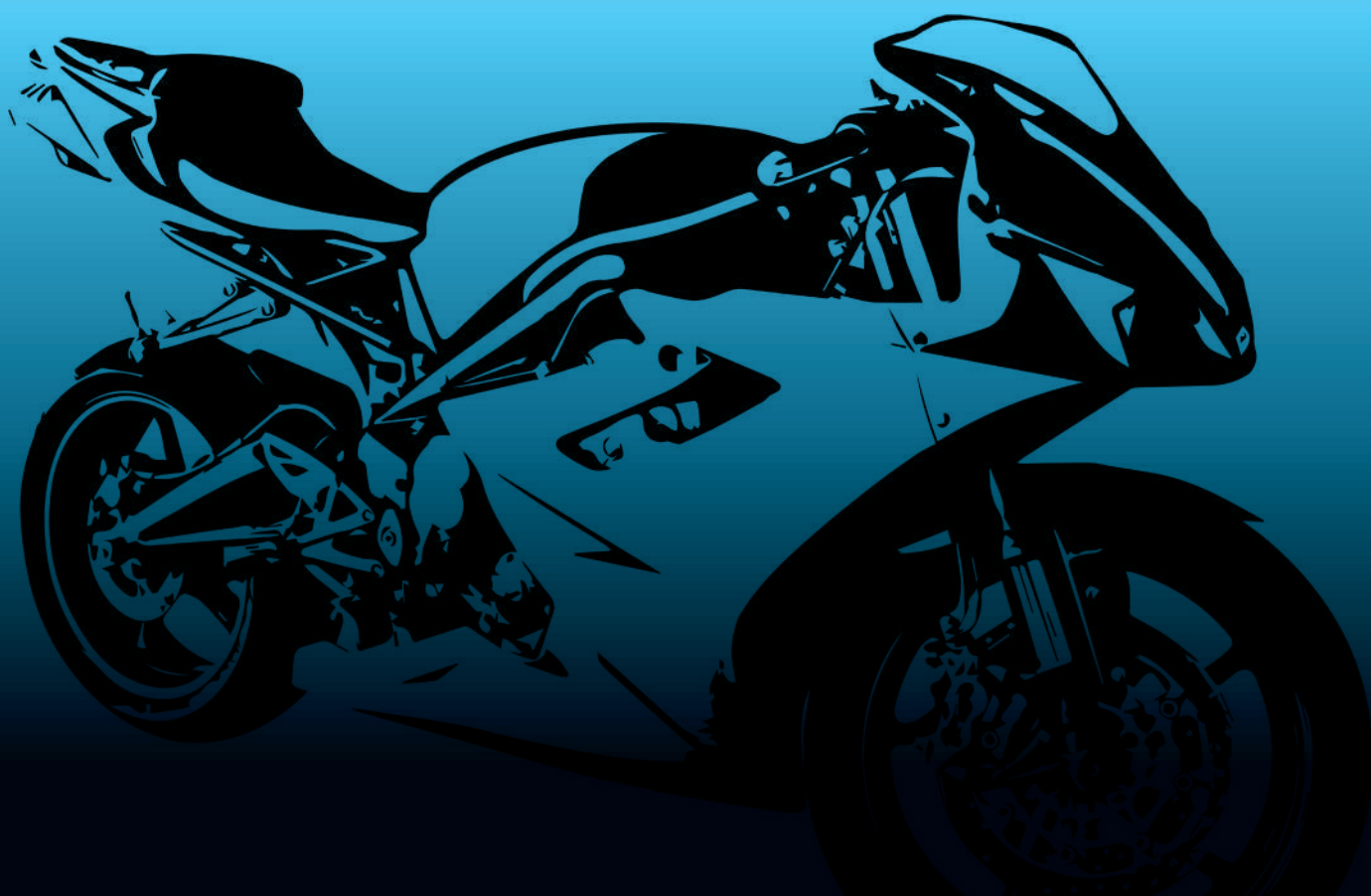

INDICE



BRAND	PAGINA
FORBIKES	9
A-SIDER	89
BARKBUSTERS	95
CLICK N' RIDE	99
DAYTONA	103
EAZI-GRIP	119
FK VISORS	139
HEL PERFORMANCE	149
KAOKO	211
NONOISE	233
R&G RACING	237

INDICE ALFABETICO

CATEGORIA	PAGINA
A	
ABBIGLIAMENTO	85
ADATTATORE POMPA FRENO	151
ADATTATORE PRESA USB	51
ADATTATORI MINI FRECCHE	63 / 238
ADATTATORI SPECCHIETTI	46
ADESIVI	76
ADESIVI ANTISCIVOLO PARASERBATOIO	121
ADESIVI ANTISCIVOLO PARATACCO	238
ADESIVI ANTISCIVOLO SERBATOIO	238
APPLICATORE STRISCE PER CERCHI	77
ATTREZZI RIMOZIONE CUSCINETTI	74
B	
BARRA MULTIFUNZIONE + PRESA USB	52
BARRE DI RICAMBIO PER SEMIMANUBRI	17
BASE APPOGGIO CAVALLETTO	238
BIDONCINO CON POMPA MULTIUSO	68
BLOCCALEVA	67
BOCCOLA INOX IMPIANTI ABS	151
BORSA DA SELLA	10
BORSETTA PORTA-ATTREZZI	10
BRACCIALE FRIZIONE	30

CATEGORIA	PAGINA
BULLONI FISSAGGIO CORONA	67
BULLONI INOX PER TUBI FRENO	151
C	
CABLAGGI / NASTRO	75
CABLAGGI SFUSI	115
CABLAGGIO FARETTI	55
CAPICORDA	112
CAPPUCCIO PER CONNETTORE	114
CARTUCCIA CO2	68
CATADIOTTRO	54
CAVALLETTI ALZAMOTO	79
CAVALLETTI ALZAMOTO OFF-ROAD	82
CAVALLETTI / BASE APPOGGIO	238
CAVALLETTI / CURSORI	83
CAVALLETTI E-BIKE	84
CAVALLETTI / FORCHETTE	83
CAVALLETTI MONOBRACCIO	81
CAVALLETTI / NOTTOLINI	84
CAVALLETTI / TAMPONI	83
CAVALLETTO IDRAULICO	82
CAVETTO PER BLOCCADISCO	12
CHIAVE A T	73
CHIAVE ESAGONALE	74

CATEGORIA	PAGINA
CHIAVE FILTRO OLIO	73
CHIAVI A BRUGOLA	74
CINGHIE ANCORAGGIO	66
CINTURA LOMBARE	86
CLICK N' RIDE / CONFEZIONE	101
CO2 / CARTUCCIA	68
COLLARE FORCELLA PER POMPA POLLICE	154
CONNETTORE CAPPUCCIO	114
CONNETTORI ELETTRICI	111
CONNETTORI FRECCHE	114
CONNETTORI H4	113
CONNETTORI HM	111
CONNETTORI HM WATERPROOF	112
CONNETTORI MT WATERPROOF	112
CONNETTORI PER MINI FRECCHE	62
CONTAGIRI DIAMETRO 48 MM	105
CONTAGIRI DIAMETRO 60 MM	106
CONTAGIRI DIAMETRO 80 MM	109
CONTAGIRI DIGITALE	109
CONTAMARCE DIGITALE	109
CONTAORE	48
CONVERTITORE SEGNALE VELOCITÀ	50
COPPIA INDICATORI DIREZIONE	60
COPPIA MANOPOLE	34
COPPIA MINI FRECCHE	59
COPRIFORO SPECCHIETTO	46 / 238
COPRIGAMBE	87
COPRIMOTO INDOOR	15
COPRIMOTO OUTDOOR	15
CORDA ELASTICA PER BAGAGLI	13
CORNICE PER STRUMENTI VELONA	107
CORNICE TARGA	71
CRICCHETTO, CHIAVE CANDELA	74
CRUISE CONTROL KAOKO	213
CUBETTI SPUGNA RACING	65
CURSORI CAVALLETTO	83
CURSORI PERNO RUOTA POSTERIORE	238
CUSCINO MEMORY FOAM	11
E	
E-BIKE CAVALLETTO	84
ELASTICI FISSAGGIO MASCHERINA OFF-ROAD	70
ELASTICI PER BAGAGLI	13
ESTENSIONE PARAFANGO	238
ESTENSIONE SPECCHIETTI	46 / 238
F	
FANALE ANTERIORE	55
FANALE ANTERIORE / PROTEZIONE TRASPARENTE	238
FANALERIA	54
FANALI / STAFFE SUPPORTO	57

CATEGORIA	PAGINA
FANALINO POSTERIORE	54
FARETTO / CABLAGGIO	55
FARETTO / SUPPORTO	55
FARETTO LED	55
FASCETTA STRINGITUBO	117 / 151
FERMACOPERTONE	66
FILO E SENSORE TEMPERATURA ACQUA / OLIO	50
FILO INOX PER PINZA GIRAFILO	74
FILO SPIRALE AD INDUZIONE	50
FLASH RELAY	62
FORCELLA / PROTEZIONE	238
FORCELLONE / PROTEZIONE	238
FORCHETTE / CAVALLETTO	83
FRECCHE	59
FRECCHE SGRANCIO RAPIDO	101
FRONTINO VISIERA TRE BOTTONI	146
G	
GIACCA SENZA MANICHE	86
GIUNTI TUBI BENZINA	68
GOMMINI CON INSERTO FILETTATO	66
GOMMINO PASSACAPO	151
GONFIAGGIO RAPIDO	68
GUAINE	116
GUANTI	87
I	
INDICATORI DI DIREZIONE SGANCIO RAPIDO	101
INDICATORI DI DIREZIONE	59
INDICATORI LED / STRUMENTAZIONE	49
INSERTO PROTEZIONE TELAIO	238
INTERMITTENZA	62
INTERRUTTORI	47
K	
KIT ALTEZZA VARIABILE RISER MANUBRIO	18
KIT COVER RAGGI CERCHI RUOTA	14
KIT MANOPOLE RISCALDATE	38
KIT MONTAGGIO PARAMANI	97
KIT TAGLIO E RIBATTITURA CATENA TRASMISSIONE	73
KIT TAGLIO RIBATTITURA PERNO A RICAMBIO	73
KIT TRASFORMAZIONE A LED	58
L	
LAMPADINA ALOGENA	58
LEVA CAMBIO	19
LEVA SMONTA GOMME	73
LEVE FRENO E FRIZIONE SYNCRO	20
LIQUIDO PULIZIA VISIERE	145
LUCE POSTERIORE PIOGGIA	238
LUCE TARGA	54
M	

CATEGORIA	PAGINA
MANIGLIE PASSEGGERO	90
MANOMETRO	74
MANOPOLE	34
MANOPOLE RISCALDATE	38
MANUBRI	16
MASCHERINA OFF-ROAD ELASTICI	70
MINI FRECCHE	59
MINI FRECCHE / ADATTATORI	238
MINI FRECCHE / CONNETTORI	62
MINI FRECCHE / RESISTENZA	62
MODIFICA MANUBRIO 22,2/28,6 MM	18
MOLLA MARMITTA	67
MORSETTI PER STAFFA MANUBRIO	18
N	
NASTRO TELATO	75
NOTTOLINI CAVALLETTO	84 / 238
O	
OFF ROAD PORTATARGA	71
OFF-ROAD CAVALLETTO ALZAMOTO	82
OFF-ROAD SFIATO PER TAPPO	70
P	
PANNO FONOASSORBENTE	73
PARACATENA	238
PARAFANGO / ESTENSIONE	238
PARAMANI	97
PARAMOTORE ADVENTURE BARS	238
PEDANE ACCOSTA MOTO	82
PEDANE ARRETRATE	238
PEDANE RACING SCOOTER	238
PELLICOLA PROTETTIVA	130
PERNO A RICAMBIO PER KIT TAGLIO RIBATTITURA	73
PERNO SGANCIO RAPIDO	66
PIASTRA PER AGGANCIAMENTO CINGHIE	238
PIATTO SUPPORTO TARGA	71
PINNA SICUREZZA CATENA	238
PINZA GIRAFILO	74
PINZA GIRAFILO / FILO INOX	74
PINZE ANTERIORI RADIALI	153
PINZE POSTERIORI ASSIALI	153
PISTONCINI ALZA-SELLA	65
PLACCHETTA POST RIMOZIONE POGGIPIEDE	238
POMPA FRENO	152
POMPA FRENO / ADATTATORE	151
POMPA FRENO INDICE	154
POMPA FRENO POLLICE	154
POMPA FRENO POLLICE / COLLARE	154
POMPA FRIZIONE	152
PORTA CELLULARE	53
PORTATARGA	238

CATEGORIA	PAGINA
PORTATARGA OFF ROAD	71
PRESA PER FRECCHE CLICK N' RIDE	101
PRESA USB	51
PRESA USB / ADATTATORE	51
PRESA USB E BARRA MULTIFUNZIONE	52
PROLUNGA SPECCHIETTI	46 / 238
PROTEZIONE AERODINAMICA LEVA	97
PROTEZIONE ANTISCIVOLO SERBATOIO	121
PROTEZIONE CENTRALE SERBATOIO	129
PROTEZIONE CODONE	238
PROTEZIONE FANALE ANTERIORE	238
PROTEZIONE LEVA FRENO/FRIZIONE	238
PROTEZIONE MONOAMMORTIZZATORE	238
PROTEZIONE RADIATORE	238
PROTEZIONE SERBATOIO / ADESIVI	76 / 238
PROTEZIONE SERBATOIO INTEGRALE	128
PROTEZIONE SILENZIATORE	14 / 238
PROTEZIONE STRUMENTAZIONE	135 / 238
PROTEZIONE TUBO SCARICO	65
PROTEZIONI FORCELLA	238
PROTEZIONI FORCELLONE	238
PROTEZIONI MOTORE	238
PROTEZIONI TELAIO	238
PROTEZIONI UDITO	235
PULITORE PARAOLI FORCELLA E SEDI	74
R	
RACCORDI RAPIDI STÄUBLI	152
RAMPA CARICO MOTO - QUAD	80
RELAY CON CONNETTORE	62
RESISTENZA MINI FRECCHE	62
RESISTENZA PER FRECCHE CLICK N' RIDE	101
RETE FERMA CARICO	12
RETINA PROTEZIONE COLLETTORI SCARICO	238
RETINA PROTEZIONE RADIATORE	238
RICETTACOLO A MOLLETTA	66
RICETTACOLO A RIVETTO	66
RIMOZIONE CUSCINETTI / ATTREZZI	74
RIPARAZIONE PNEUMATICI	67
RISER MANUBRIO	18
RIVETTO A CLIP	67
RONDELLA IN RAME	152
RONDELLE TEFLON	66
RULLINO CATENA	70
S	
SALVACHIAPE	11
SAPONETTE	86
SCALDACOLLO	86
SCARICO / STAFFA	238
SCARICO / PROTEZIONE	65 / 238

CATEGORIA	PAGINA
SCHIACCIATUBO	117
SEGNALE VELOCITÀ / CONVERTITORE	50
SELLA IN NEOPRENE	12
SEMIMANUBRI / BARRE DI RICAMBIO	17
SEMIMANUBRI RACING	17
SEMIMANURBI RIALZATI	17
SENSORE DI VELOCITÀ	50
SERBATOIO FRENI / STAFFA SUPPORTO	72
SERBATOIO LIQUIDO FRENI	71
SFIATO PER TAPPO OFF-ROAD	70
SLIDERS CODONE POSTERIORE	238
SLIDERS SERBATOIO	238
SMARTPHONE SUPPORTO	53
SMONTAGOMME / LEVE	73
SOFFIETTI COPERTURA SNODO PEDANE MX	65
SOTTOCASCO	86
SPECCHIETTI	43
SPECCHIETTI / ADATTATORI	46
SPECCHIETTI / COPRIFORO	46 / 238
SPECCHIETTI / ESTENSIONE	46 / 238
SPINE FERMA-PASTIGLIE	67
SPINE STOPPA FLUIDO OLIO E CARBURANTE	74
SPUGNA SERBATOIO	65
STABILIZZATORI / TAMPONI MANUBRIO	238
STABILIZZATORI MANUBRIO	40
STAFFA MANUBRIO	18
STAFFA MANUBRIO / ADATTATORE	18
STAFFA MANUBRIO / MORSETTI	18
STAFFA PER VELONA 48 MM	105
STAFFA PER VELONA 60 MM	107
STAFFA SPECCHIETTI	46 / 238
STAFFA SUPPORTO SCARICO	238
STAFFA SUPPORTO SERBATOIO FRENI	72
STAFFE SUPPORTO FANALI	57
STAMPELLA LATERALE	82
STÄUBLI RACCORDI RAPIDI	152
STRINGITUBO / FASCETTA	117 / 151
STRISCE PER CERCHI	77
STRISCE PER CERCHI / APPLICATORE	77
STRISCIA A MANUBRIO ANCORAGGIO CINGHIE	66
STRUMENTAZIONE MULTIFUNZIONE	110
STRUMENTO / INDICATORI LED	49
SUPPORTO FARETTO A LED	55
SUPPORTO SMARTPHONE	53
SUPPORTO SPECCHIO	46
SUPPORTO TARGA	71
SYNCRO LEVE FRENO E FRIZIONE	20
T	
TACHIMETRO DIAMETRO 48 MM	105

CATEGORIA	PAGINA
TACHIMETRO DIAMETRO 60 MM	106
TACHIMETRO DIAMETRO 80 MM	108
TACHIMETRO DIGITALE	109
TAMPONI / PROTEZIONI TELAIO	238
TAMPONI CAVALLETTO	83
TAPPETO	238
TAPPI PROTEZIONE UDITO	235
TAPPINO IN GOMMA SPURGO PINZA/POMPA	14
TAPPO CARICO OLIO MOTORE	72
TAPPO PER MARMITTA	13
TAPPO RADIATORE	65
TAPPO SERBATOIO OLIO FRENI	72
TAPPO VALVOLA	14
TARGA / SUPPORTO	71
TELO COPRIMOTO INDOOR	15
TELO COPRIMOTO OUTDOOR	15
TELO ELASTICO PER BAGAGLI	13
TERMINALI CAPICORDA	112
TERMINALI MANUBRIO	40
TERMINALI PER HM/MT	112
TERMOCOPERTE	69
TERMOMETRO DIGITALE	109
TESSUTO FONOASSORBENTE	73
TESSUTO TERMORIFRANGENTE	73
TRASFORMAZIONE A LED	58
TUBI FRENO IN TRECCIA	155
TUBI IN SILICONE	133
TUBO CARBURANTE	117
TUBO CON VALVOLA SFIATO	70
TUBO PASSACAVO	116
TUTA ANTIACQUA	85
U	
USB PRESA	51
V	
VALVOLE PNEUMATICI RACING	70
VISIERA DI PROTEZIONE CERTIFICATA	147
VISIERE	141
VISIERE / LIQUIDO PULIZIA	145
VITE SPURGO ACCIAIO INOX	151
VOLTMETRO	50

CONDIZIONI GENERALI DI VENDITA

PRODOTTI:

FORBIKES non si assume nessuna responsabilità in merito alla completezza, correttezza ed aggiornamento del catalogo. Le caratteristiche e i dati tecnici relativi ai prodotti presenti in questo catalogo non sono impegnativi e possono essere modificati senza alcun preavviso.

MARCHI:

I seguenti marchi registrati con i nomi: Aprilia, Ducati, Honda, Kawasaki, Suzuki, Triumph, MV Agusta, Yamaha e altri sono di proprietà delle rispettive Case e vengono qui utilizzati solo a titolo descrittivo.

INOLTRO ORDINI:

Verranno accettati ed evasi secondo la disponibilità del momento.

Si accettano ordini a mezzo fax, e-mail, tramite il ns. sito web aziendale o tramite agente di zona.

Gli ordini o le variazioni di ordini già inviati non verranno accettati telefonicamente.

Per ordini inferiori a € 100,00 I.VA. esclusa, verrà applicato pagamento in contrassegno con addebito di spese incasso contrassegno e spese di trasporto.

GESTIONE INEVASI (BACK-ORDER):

FORBIKES gestisce i back-order (inevasi); gli articoli ordinati ma rimasti in back-order verranno quindi spediti SEMPRE non appena disponibili a magazzino, con il prossimo ordine o singolarmente.

Il cliente potrà comunque fare espressa richiesta di annullamento back-order via fax o e-mail o semplicemente indicando la dicitura "annullare inevasi precedenti" al momento dell'invio di un ordine successivo.

CONSEGNA & TRASPORTO:

La merce viene spedita a mezzo ns. corriere convenzionato in Porto Franco Destino, senza alcun tipo di copertura assicurativa e con addebito in fattura, per tutte le spedizioni salvo casi particolari da concordare tra le parti.

Resta inteso che la merce viaggia comunque a rischio e pericolo del committente.

FORBIKES non è responsabile per ritardi nelle consegne rispetto a quanto stabilito, e non riconoscerà in alcun modo eventuali danni conseguenti.

ARTICOLI DIFETTOSI:

FORBIKES si impegna a sostituire gli articoli difettosi o danneggiati durante il trasporto.

In quest'ultimo caso sarà necessario firmare la ricevuta del corriere con "riserva di verifica" se gli imballi risultano esteriormente e visibilmente danneggiati.

PAGAMENTI:

Sono da effettuarsi esclusivamente al ns. domicilio di Reggio Emilia, senza sconti o arrotondamenti.

Pagamenti al ns. personale non espressamente autorizzato sono a rischio e pericolo del Cliente.

Salvo accordi contrattuali diversi, i pagamenti accettati sono: bonifico anticipato, contrassegno (assegno bancario non trasferibile intestato al mittente o contanti) o RIBA e gli stessi devono essere concordati direttamente con il ns. agente di zona.

Le spese per i pagamenti a mezzo RIBA verranno addebitate su fattura a carico del Cliente.

Per pagamenti ritardati oltre i limiti previsti dalla fattura, verranno addebitati interessi nella misura pari agli interessi legali maggiorati di tre punti percentuali e relative spese.

FORBIKES si riserva la possibilità di sospendere le eventuali forniture in corso e/o successive in caso di mancato pagamento di forniture precedenti. La merce resta di proprietà della FORBIKES fino ad estinzione del pagamento.

RESI MERCE - GARANZIE:

Non si accettano resi merce se prima non autorizzati dal ns. Ufficio Commerciale e comunque dovranno essere comunicati entro 10gg. lavorativi dal ricevimento della merce. La richiesta di autorizzazione al reso dovrà essere inviata a FORBIKES tramite la compilazione dell'apposito modulo allegato al catalogo e successivamente confermata da FORBIKES con l'invio al cliente dello stesso modulo "RIENTRO MERCE AUTORIZZATO".

Tutti i resi dovranno essere comunque spediti Franco ns. magazzino di Reggio Emilia a spese del cliente, salvo diversa disposizione.

La responsabilità di FORBIKES resta limitata alla sostituzione o al rimborso del prezzo dell'articolo in questione, tramite nota di credito. FORBIKES declina ogni responsabilità per danni arrecati a terzi e/o a parti complementari, dalla merce fornita, danni derivanti alle operazioni di montaggio/smontaggio della medesima.

Resta inteso che non si provvederà a rimborso alcuno di spese relative alla manodopera per assemblaggio, lavorazione o altro (fermo tecnico ecc..).

CONTESTAZIONI:

Per qualsiasi controversia il Foro competente è quello di Reggio Emilia.

TRATTAMENTO DATI:

FORBIKES è responsabile del trattamento dei dati ai sensi della tutela della PRIVACY.

Consultare www.forbikes.it > sezione Informativa sulla Privacy. Una copia informativa completa è disponibile su richiesta.

Per presa visione di quanto sopra il cliente accetta ogni condizione di vendita

PERSONALIZZAZIONI

FORBIKES offre la possibilità di personalizzare con il vostro logo aziendale, tutti i prodotti contenuti nel catalogo contrassegnati con la dicitura "PERSONALIZZABILE".

La personalizzazione viene eseguita internamente tramite processo di tampografia o stampa al laser, a seconda del prodotto che si desidera marcare.

Questa pratica offre l'opportunità di promuoversi in modo efficace, e dare visibilità alla vostra azienda con prodotti strettamente inerenti al Vs. settore di riferimento.

Ogni richiesta di personalizzazione deve essere oggetto di stima dedicata relativamente a: tempi, numero pezzi minimi, costi impianto iniziale, modalità di stampa, modalità di consegna e fornitura, modalità di pagamento.

Potete inviare la Vs. richiesta di personalizzazione, scrivendo una mail all'indirizzo commerciale@forbikes.it

FORBIDDEN



FORBIKES S.R.L.
COMPONENTI PER MOTORCICLI

BORSETTA PORTA-ATTREZZI A PARAFANGO

00-0040 Nero



Si fissa mediante viti e bulloni
140x220x90 mm

BORSA DA SELLA "HENLYBEGINS" DH-708, 4 LT

95734 Nero-Carbon

95735 Rosso-Carbon

95736 Blu-Carbon

95741 Nero



In pelle finta e poliestere
Include cover per pioggia
285x250x110 mm



BORSA DA SELLA "HENLYBEGINS" DH-723, 6 LT

97087 Nero



In pelle finta e poliestere
Include cover per pioggia
300x250x185 mm

DAYTONA

BORSA DA SELLA "HENLYBEGINS" DH-710, 7 LT

96043 Nero



In pelle finta e Nylon
Include cover per pioggia
285x235x145 mm



BORSA DA SELLA "HENLYBEGINS" DH-722/A4, 7-12 LT

97241 Nero



In poliestere
Include cover per pioggia
345x250x150-220 mm



CUSCINO MEMORY FOAM IN GEL SALVACHIAPPE



Cuscino dal nome provocante, senza fronzoli o termini incomprensibili, dopo infiniti tentativi, dopo reali KM di test effettuati direttamente dai nostri più fedeli clienti, abbiamo affinato un prodotto decisamente performante: dall'unione di una particolare MEMORY FOAM (prodotta per nostra esclusiva ad alta portanza) con il ben noto gel, nasce il prorompente SALVACHIAPPE!! Del quale il nome non vuole solo essere una trovata commerciale ma una concretezza!!

Pratico da installare, viene fornito in tre formati principali, adattabili alla maggior parte di moto in circolazione, il montaggio richiede davvero pochi minuti, ideale per chi non vuole intervenire sulla struttura originale della sella, perfetto per chi non vuole storpiare l'estetica affusolata di una seduta sportiva fino al primo viaggio dove il dolore la rende davvero odiosa e davvero performante nella sua funzione in quanto migliorerà notevolmente il comfort senza avere la fastidiosa sensazione di galleggiamento causata da altri noti cuscini ad aria, grazie al suo particolare rivestimento antiscivolo, l'aderenza non sarà compromessa e di conseguenza nemmeno il vostro stile di guida.

Spessore 3 cm.

MONTAGGIO IN TRE SEMPLICI FASI



1. Rimuovete la sella dalla propria sede sulla motocicletta;
2. Una volta appoggiato il cuscinetto nella posizione più corretta da voi individuata fate aderire tra loro i velcri appositamente fissati agli elastici nella parte sottostante alla struttura in plastica (n.b. nel caso gli elastici risultassero lunghi potete incrociarli tra loro per ottenere un miglior tiraggio vedi foto);
3. Reinstallate nel proprio alloggio la sella facendo attenzione che gli elastici non intralcino i relativi sistemi di fissaggio.

TIPO A

00-0591

lunghezza max 23 cm



TIPO B

00-0601

lunghezza max 23,5 cm



TIPO C

00-0611

lunghezza max 27 cm



SELLA IN NEOPRENE ADESIVO PER CARENE IN VTR, SPESSORE 1 CM

Tipo A

00-0391

lunghezza max 17 cm



lunghezza max 30 cm

altezza max 29 cm

Tipo B

00-0401

lunghezza max 20,5 cm



lunghezza max 27 cm

altezza max 34,5 cm

Tipo C

00-0411

lunghezza max 29 cm



lunghezza max 28 cm

altezza max 32,5 cm

PERSONALIZZABILE

Realizzazione selle in neoprene con misure di vostra indicazione

CAVETTO "MEMORY" PER BLOCCADISCO

00-0150



Lunghezza max 128 cm

PERSONALIZZABILE

RETE ELASTICA FERMA CARICO RINFORZATA 380X380 MM

00-0230 Nero

00-0233 Blu

00-0234 Rosso

00-0235 Giallo fluo

NEW

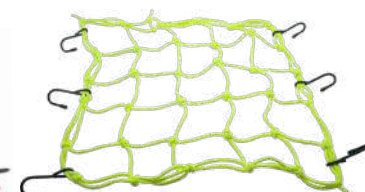
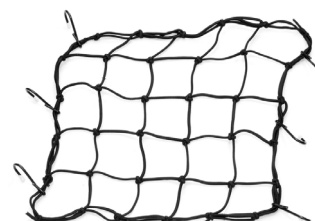
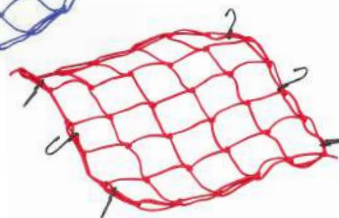

RETE FERMA CARICO 400X400 MM

72733 Nero

77789 Rosso

77790 Blu

NEW

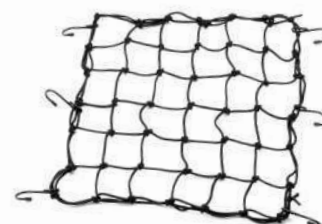

DAYTONA

NEW**RETE FERMA CARICO CON CUSTODIA****72182** 300x300 mm**72185** 400x400 mm**72188** 500x500 mm**72191** 600x600 mm

72182



72185



72188



72191



Include 6 ganci e la custodia

DAYTONA**CORDA ELASTICA PER BAGAGLI****72210** 1500 mm**72213** 2500 mm**72216** 3500 mm**72219** Giunzione a X, 1000 mm x2**NEW**

72210



72213



72216



72219

**DAYTONA****TELO ELASTICO PER BAGAGLI CON GANCI****73223** 400x500 mm**73257** 420x600 mm**NEW****TAPPO PER MARMITTA****00-0564** Piccolo 2T, 35 mm, rosso**00-0575** Grande 4T, 55 mm, giallo**DAYTONA**

TAPPINO IN GOMMA COLORATO SPURGO PINZA/POMPA

00-0581	Nero
00-0583	Blu
00-0584	Rosso
00-0585	Giallo
00-0587	Arancio
00-0588	Verde



COPPIA TAPPO VALVOLA "HEXAGONE"

12-0010	Argento
12-0013	Blu
12-0014	Rosso
12-0015	Oro



KIT COVER RAGGI CERCHI RUOTA 18"-21"

00-0690	Bianco
00-0691	Nero
00-0693	Blu
00-0694	Rosso
00-0695	Giallo fluo
00-0696	Rosa scuro
00-0697	Arancio
00-0698	Verde fluo



Anteriori 38 pezzi 8,5"
Posteriori 38 pezzi 8,5"

PROTEZIONE SILENZIATORE 6" (15 CM), SILENZIATORI 127-152 MM

00-0701	Nero
00-0702	Bianco
00-0703	Blu
00-0704	Rosso
00-0705	Giallo
00-0707	Arancio
00-0708	Verde



PERSONALIZZABILE

PROTEZIONE SILENZIATORE 5" (12,7 CM), SILENZIATORI 102-127 MM

00-0711	Nero
00-0712	Bianco
00-0713	Blu
00-0714	Rosso
00-0715	Giallo
00-0717	Arancio
00-0718	Verde

PERSONALIZZABILE

TELI COPRIMOTO



TELO COPRIMOTO OUTDOOR FORBIKES

00-0640 Taglia S (198x98 cm)

00-0650 Taglia M (223x121 cm)

00-0660 Taglia L (229x125 cm)



Impermeabile
Interno rivestito in cotone
Protegge la carena e i
componenti meccanici ed
elettrici

Fino ad esaurimento



TELO COPRIMOTO INDOOR FORBIKES

00-0721L Taglia L, nero

00-0721XL Taglia XL, nero

00-0723L Taglia L, blu

00-0723XL Taglia XL, blu

00-0724L Taglia L, rosso

00-0724XL Taglia XL, rosso



Elasticizzato su quattro lati
Si adatta perfettamente
ad ogni modello

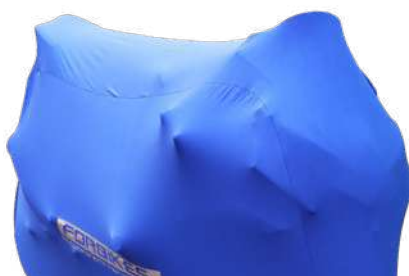

Aggiornamenti sul sito www.forbikes.it

È vietato l'utilizzo su strada pubblica degli articoli non omologati.

FORBIKES
COMPONENTI PER MOTOCICLI

MANUBRIO "ALUMINIUM BICOLOR" ANODIZZATO

12-0743	Nero con inserti blu
12-0744	Nero con inserti rosso
12-0747	Nero con inserti arancio
12-0748	Nero con inserti verde

Diametro 28,6 mm
 Tacche di posizione per facilitare il montaggio e
 impugnatura dotata di scanalature per una fissaggio
 migliore tra manopole e manubrio



PERSONALIZZABILE

MANUBRIO AL6061 ANODIZZATO

DIAMETRO 22,2 MM

12-0370	Medio	Argento
12-0371	Medio	Nero
12-0373	Medio	Blu
12-0374	Medio	Rosso
12-0375	Medio	Oro
12-0380	Basso	Argento
12-0381	Basso	Nero
12-0383	Basso	Blu
12-0384	Basso	Rosso
12-0385	Basso	Oro
12-0390	Extra basso	Argento
12-0391	Extra basso	Nero
12-0393	Extra basso	Blu
12-0394	Extra basso	Rosso
12-0395	Extra basso	Oro

DIAMETRO 28,6 MM

12-0400	Medio	Argento
12-0401	Medio	Nero
12-0410	Extra basso	Argento
12-0411	Extra basso	Nero



DIMENSIONI:

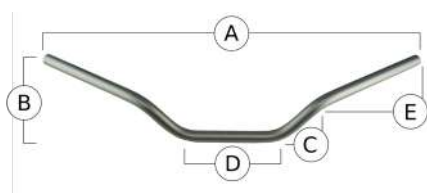

DIAMETRO 22,2 MM

	A	B	C	D	E
MEDIO	725	115	85	185	105
BASSO	755	100	60	195	80
EXTRA BASSO	725	75	50	185	95

DIAMETRO 28,6 MM

	A	B	C	D	E
MEDIO	725	115	85	185	105
EXTRA BASSO	725	75	50	185	95

COPPIA SEMIMANUBRI RACING, INCLINAZIONE 7° E DIAMETRO 22,2 MM

	41 mm	43 mm	45 mm	48 mm	50 mm	52 mm	54 mm
Alluminio	12-0430	12-0440	12-0450	12-0460	12-0470	12-0480	12-0490
Nero	12-0431	12-0441	12-0451	12-0461	12-0471	12-0481	12-0491



PERSONALIZZABILE

COPPIA SEMIMANUBRI RIALZATI 45 MM, INCLINAZIONE REGOLABILE

	41 mm	43 mm	45 mm	48 mm	50 mm	52 mm	54 mm
Alluminio	12-0510	12-0520	12-0530	12-0540	12-0550	12-0560	12-0570
Nero	12-0511	12-0521	12-0531	12-0541	12-0551	12-0561	12-0571



PERSONALIZZABILE

COPPIA BARRE DI RICAMBIO PER SEMIMANUBRI RACING

- 12-0500** Alluminio
- 12-0501** Nero

COPPIA BARRE DI RICAMBIO PER SEMIMANUBRI RIALZATI-REGOLABILI

- 12-0580** Alluminio
- 12-0581** Nero



Diametro 22,2 mm
Lunghezza 28,5 mm

Diametro 22,2 mm
Lunghezza 28,5 mm

KIT ALTEZZA VARIABILE RISER MANUBRIO

12-0240 22,2 mm

12-0680 28,6 mm



COPPIA RISER MANUBRIO 28,6 MM FISSAGGIO SILENT BLOCK CONICI

12-0251



Altezza 32 mm
Vite sfilabile

COPPIA RISER MODIFICA MANUBRIO DA 22,2 A 28,6 MM

12-0611



STAFFA MANUBRIO ANODIZZATA, NERO

NEW

99426 150 mm

99432 200 mm

99438 250 mm



COPPIA MORSETTI PER STAFFA MANUBRIO ANODIZZATI

NEW

99445 Diametro 22,2 mm



ADATTATORE STAFFA MANUBRIO, NERO

NEW

99474 50 mm

99468 100 mm



**LEVA CAMBIO ALLUMINIO
HONDA CRF**

01-0014 Rosso



**LEVA CAMBIO ALLUMINIO
YAMAHA YZ/YZF**

01-0023 Blu



**LEVA CAMBIO ALLUMINIO
YAMAHA YZ/YZF/WR**

01-0033 Blu



LEVA CAMBIO ALLUMINIO KTM

01-0047 4 tempi arancio

01-0057 2 tempi arancio



LEVA CAMBIO ALLUMINIO KTM LC4

01-0067 Arancio



**LEVA CAMBIO ALLUMINIO
KAWASAKI/SUZUKI 250 4T**

01-0070 Lucido



**LEVA CAMBIO ALLUMINIO
KAWASAKI KX 2T**

01-0080 Lucido



**LEVA CAMBIO ALLUMINIO
SUZUKI RM**

01-0095 RM 125 oro

01-0105 RM 250 oro



**LEVA CAMBIO ALLUMINIO
SUZUKI 450Z**

01-0145 Oro



LEVE SYNCRO



LEVE FRENO E FRIZIONE "SYNCRO"

APPLICATIVO MOTO A SEGUIRE

Disponibili solo in colore nero.
Regolabili in lunghezza/distanza e reclinabili.

Specificare sempre il colore del pezzo finale.



Possibilità di acquistare anche solamente la parte finale a ricambio.



PEZZO PARTE FINALE A RICAMBIO LEVA "SYNCRO"

- | | |
|----------|----------------|
| 01-END00 | Alluminio |
| 01-END07 | Grigio titanio |
| 01-END01 | Nero |
| 01-END03 | Blu |
| 01-END04 | Rosso |
| 01-END05 | Oro |
| 01-END07 | Arancio |
| 01-END08 | Verde |



APPLICATIVO LEVE "SYNCRO"

MODELLO	ANNI	CODICE FRENO	CODICE FRIZIONE
APRILIA			
RSV4/RSV4 FACTORY	2009-2015	01-F111	01-V41
RSV MILLE / R	2004-2008	01-F111	01-H111
RSV MILLE / R	1999-2003	01-DB801	01-DC801
TUONO / R	2003-2009	01-DB801	01-DC801
TUONO V4R	2011-2015	01-DB801	01-V41
FALCO / SL1000	2000-2004	01-DB801	01-DC801
CAPONORD / ETV1000	2002-2007	01-F161	01-DC801
CAPONORD 1200	2014	01-DB801	01-DC801
RST1000 FUTURA	2001-2004	01-F161	01-DC801
SHIVER / GT	2007-2015	01-F231	01-C231
DORSODURO 750	2008-2015	01-F231	01-C231
DORSODURO 1200	2011-2015	01-DB801	01-DC801
MANA	2007-2012	01-F231	Non disponibile
BENELLI			
TNT R160	2010-	01-F111	01-H111
BIMOTA			
DB5S	2008	01-F161	01-DC801
DB6R	2008	01-F111	01-H111
TESI 3D	2008	01-F111	01-H111
BMW			
F650GS	2008-2012	01-B11	01-B81
F700GS	2013-2016	01-B11	01-B81
F800S	2006-2013	01-B11	01-B81
F800ST	2006-2015	01-B11	01-B81
F800GS	2008-2016	01-B11	01-B81
F800R	2009-2015	01-B11	01-B81
F800GT	2013-2015	01-B11	01-B81
S1000RR	2010-2014	01-F221	01-B221
S1000R	2014	01-F221	01-B221
K1200R	2005-2008	01-B11	01-B21
K1200R SPORT	2006-2008	01-B11	01-B21
K1200S	2004-2008	01-B11	01-B21
R1200R	2006-2014	01-B11	01-B21
R1200RT/SE	2010-2013	01-B11	01-B21
R1200S	2006-2008	01-B11	01-B21
R1200ST	2005-2008	01-B11	01-B21
R1200GS	2004-2012	01-B11	01-B21
R1200GS ADVENTURE	2006-2013	01-B11	01-B21
K1300 S/R/GT	2009-2015	01-B11	01-B21
K1600 GT/GTL	2011-2015	01-B11	01-B21
HP2 SPORT	2008-2011	01-M11	01-M111
BUELL			

MODELLO	ANNI	CODICE FRENO	CODICE FRIZIONE
1125R	2008-2009	01-F141	01-C7771
1125CR	2009	01-F141	01-C7771
1130	2005-2007	01-D801	01-HLC1
XB12R	2009	01-F141	01-B551
XB12SS	2009	01-F141	01-B551
XB12SCG	2009	01-F141	01-B551
ULYSSES XB12XT	2009	01-F201	01-B551
ULYSSES XB12X	2009	01-F201	01-B551
XB12 ALL MODELS UP TO 08 ONLY	2004-2008	01-F201	01-B551
XB9 ALL MODELS	2003-2009	01-F201	01-B551
X1 LIGHTNING	1998-2002	01-F141	01-B551
S1 LIGHTNING	1997-1998	01-F141	01-B551
M2 CYCLONE	1997-2002	01-F141	01-B551
DUCATI			
DIAVEL/CARBON	2011-2015	01-F111	01-H111
749/S/R	2003-2006	01-F111	01-H111
HYPERMOTARD 796	2010-2012	01-DB121	01-D221
HYPERMOTARD 821 SP	2013-2015	01-D011	01-D821
HYPERMOTARD 821/ STRADA	2013-2015	01-DB121	01-D821
MONSTER 821	2014-2015	01-DB121	01-D821
848/EVO	2007-2013	01-F111	01-H111
STREETFIGHTER /S	2009-2013	01-F111	01-H111
STREETFIGHTER 848	2012-2015	01-F111	01-H111
899 PANIGALE	2014-2015	01-F991	01-H111
999/S/R	2003-2006	01-F111	01-H111
1098/S/TRICOLOR	2007-2008	01-F111	01-H111
MTS1100/S	2007-2009	01-DB801	01-DC801
M1100/S/EVO MONSTER	2009-2013	01-F111	01-H111
HYPERMOTARD 1100/S/ EVO SP	2007-2012	01-D011	01-H111
1198/S/R	2009-2011	01-F111	01-H111
1199 PANIGALE/S/ TRICOLOR	2012-2015	01-F991	01-H111
MULTISTRADA 1200/S	2010-2015	01-F111	01-H111
MONSTER 1200/S	2014-2015	01-F991	01-H111
MONSTER 1200	2014-2015	01-F111	01-H111
S4RS	2006-2008	01-F111	01-H111
MS4/MS4R	2001-2006	01-DB801	01-DC801
M900/M1000	2000-2005	01-DB801	01-DC801
900SS/1000SS	1998-2006	01-DB801	01-DC801
996/998/B/S/R	1999-2003	01-DB801	01-DC801
748/750SS	1999-2002	01-DB801	01-DC801
MTS1000SDS/DS	2004-2006	01-DB801	01-DC801
ST4S	2003	01-DB121	01-D221

APPLICATIVO LEVE "SYNCR0"

MODELLO	ANNI	CODICE FRENO	CODICE FRIZIONE
ST4/S/ABS	2004-2006	01-DB801	01-DC801
ST3/S/ABS	2003-2007	01-DB801	01-DC801
SPORT 1000	2006-2009	01-DB801	01-DC801
GT 1000	2006-2010	01-DB801	01-DC801
DUCATI PAUL SMART LE	2006	01-DB801	01-DC801
S2R 1000	2006-2008	01-DB801	01-DC801
400 MONSTER	2004-2007	01-DB121	01-D221
620 MONSTER / 620 MTS	2003-2006	01-DB121	01-D221
695 MONSTER	2007-2008	01-DB121	01-D221
696 MONSTER	2009-2014	01-DB121	01-D221
796 MONSTER	2011-2014	01-DB121	01-D221
821 MONSTER	FINO 2021	01-DB121	Solo freno
MONSTER S2R 800	2005-2007	01-DB121	01-D221
748	FINO AL 1998	01-DB121	01-DC121
916/916SPS	FINO AL 1998	01-DB121	01-DC121
900SS	1991-1997	01-DB121	01-DC121
MONSTER M400	1999-2003	01-DB121	01-DC121
MONSTER M600	1994-2001	01-DB121	01-DC121
MONSTER M620	2002	01-DB121	01-DC121
MONSTER M750/M750IE	1994-2002	01-DB121	01-DC121
MONSTER M900	1994-1999	01-DB121	01-DC121
ST2	1998-2003	01-DB121	01-DC121
ST4/4S/ST4S ABS	1999-2002	01-DB121	01-DC121
HONDA			
CBR250	2010-2012	01-FX121	01-H6061
CBR250R	2011-2013	01-F251	01-H2501
CBR300R	2011	01-F251	01-RS100L1
CBR300R	2014-2015	01-F251	01-H2501
CBR500R/CB500F/X	2013-2015	01-F251	01-H2501
CB599 / CB600 HORNET	1998-2006	01-F181	01-H6261
CB600F HORNET	2007-2016	01-F181	01-H6071
CBR 600F	2011-2013	01-F181	01-H6071
CBR650F / CB650F	2014-2015	01-F181	01-H651
CBR 600 F2,F3,F4,F4I	1991-2007	01-F181	01-H6261
CBR600RR	2003-2006	01-F291	01-Y688H1
CBR600RR	2007-2016	01-F331	01-Y688H1
CBF600/SA	2010-2013	01-F181	01-H6071
NC700 S/X	2012-2013	01-F181	01-H6261
NC700 S/X	2014-2015	01-F181	Solo freno
VF750S SABRE	1982-1986	01-F181	01-V001
VFR750	1991-1997	01-F181	01-V001
VFR800	1998-2001	01-FXX1	01-V001
VFR800/F	2002-2016	01-F181	01-V001
CB919	2002-2007	01-F181	01-H6261
CBR900RR	1993-1999	01-F181	01-H6261

MODELLO	ANNI	CODICE FRENO	CODICE FRIZIONE
CBR929RR	2000-2001	01-F291	01-H6261
CBR954RR	2002-2003	01-F291	01-Y688H1
CB1000R	2008-2015	01-F331	01-H331
CBR1000RR / FIREBLADE	2004-2007	01-F331	01-H331
CBR1000RR / FIREBLADE/ SP	2008-2016	01-F331	01-Y688H1
RC51 / RVT1000 SP-1/ SP-2	2000-2006	01-F291	01-H331
VTR1000F / FIRESTORM	1998-2005	01-F181	01-V001
CBF1000	2006-2009	01-F181	01-V001
CBF1000/A	2010-2013	01-F181	01-H331
CB1100/GIO SPECIAL	2013-2015	01-F181	01-H331
CBR1100XX / BLACKBIRD	1997-2007	01-FXX1	01-V001
VFR 1200/F	2010-2014	01-F121	01-H331
VFR 1200/F	2014-2015	01-F121	Solo freno
CB1300 X4	2003-2010	01-F181	01-H331
ST1300/ST1300A	2003-2008	01-FXX1	01-V001
ST1300	2008-2012	01-F121	01-V001
VTX1300	2003-2008	01-F181	01-H6261
X-11	1999-2002	01-FXX1	01-H6261
BLACK SPIRIT	2014-2015	01-F181	01-H2501
KAWASAKI			
NINJA 250R	2008-2012	01-F251	01-K251
NINJA 300R	2013-2016	01-F251	01-K251
ZXR400	TUTTI GLI ANNI	01-F141	01-K7501
NINJA 400R	2011-2012	01-F441	01-K7501
GPZ500S/EX500R NINJA	1990-2009	01-F141	01-K7501
ER-5	2004-2005	01-F141	01-K7501
ZX-6 / ZZR600	1990-2004	01-F141	01-K7501
ZZR600	1990-2004	01-F141	01-K7501
ZZR600	2005-2009	01-F141	01-K8281
ZX6R / ZX636R / ZX6RR	2000-2004	01-F141	01-K8281
ZX636R / ZX6RR	2005-2006	01-F351	01-K8281
ZX6R/636	2007-2016	01-F881	01-K8281
ER-6N/F	2009-2016	01-F441	01-K7501
VERSYS 650	2006-2008	01-F141	01-K7501
VERSYS 650	2015-2019	01-F201	01-K7501
VULCAN S 650		01-F201	01-K7501
VERSYS 650	2009-2014	01-F441	01-K7501
NINJA 650R/ER-6F/ER-6N	2006-2008	01-F141	01-K7501
NINJA 650	2017-2019	01-F201	01-K7501
NINJA 650R/ER-6F	2009-2015	01-F441	01-K7501
ZX7R / ZX7RR	1989-2003	01-F141	01-C7771
ZR750 ZEPHYR	1991-1993	01-F141	01-K7501
Z750 (NOT Z750S MODEL)	2007-2012	01-F201	01-K8281

APPLICATIVO LEVE "SYNCRO"

MODELLO	ANNI	CODICE FRENO	CODICE FRIZIONE
Z750	2004-2006	01-F141	01-K7501
Z750S (NOT Z750 MODEL)	2006-2008	01-F141	01-K7501
Z750R	2011-2012	01-F881	01-K8281
Z800/E VERSION	2013-2015	01-F201	01-K8281
W800/SE	2012-2014	01-F141	01-K7501
Z900	2017-2019	01-F201	01-K7501
ZX9	1994-1997	01-F141	01-C7771
ZX9R	1998-1999	01-F141	01-K7501
ZX9R	2000-2003	01-F141	01-K8281
ZG1000 CONCOURS	1992-2006	01-F141	01-C7771
Z1000SX/NINJA 1000	2011-2016	01-F881	01-K8281
VERSYS 1000	2012-2014	01-F141	01-K8281
ZX10R	2004-2005	01-F141	01-K8281
ZX10R	2016-2019	01-F991	01-H111
ZX10R	2006-2015	01-F881	01-K8281
NINJA H2 /H2R		01-F991	01-H111
Z1000	2003-2006	01-F141	01-K8281
Z1000	2007-2016	01-F881	01-K8281
Z1000 R	2017-2019	01-F881	01-K8281
Z1000 ABS	2017-2019	01-F881	01-K8281
VERSYS 1000	2015-2018	01-F201	01-K7501
ZX1100 / ZX-11	1990-2001	01-F141	01-C7771
ZRX1100 / 1200	1999-2007	01-F141	01-C7771
ZX12R	2000-2005	01-F141	01-K8281
ZZR1200	2002-2005	01-F141	01-C7771
ZX1400 / ZX14R / ZZR1400	2006-2015	01-F881	01-H881
GTR1400 / CONCOURS	2007-2015	01-F881	01-H881
KTM			
200 DUKE	2013-2016	01-FK121	01-DK121
390 DUKE	2013-2016	01-FK121	01-DK121
RC 390	2013-2018	01-FK121	01-DK121
690 ENDURO R	2014-2018	01-DB121	01-A901
690 DUKE R	2014-2015	01-F111	01-A901
690 DUKE/SMC/SMC-R	2014-2015	01-DB121	01-A901
990 SUPERDUKE	2005-2012	01-F111	01-M111
RC8/R	2009-2015	01-F111	01-M111
1090 ADVENTURE / R	2017-2018	01-DB121	01-A901
1190 ADVENTURE / R	2013-2016	01-D011	01-A901
1190 SUPERADVENTURE	2015	01-D011	01-A901
1290 SUPERDUKE R	2014-2015	01-F111	01-M111
1290 SUPERADVENTURE R/S	2017-2019	01-D011	01-A901
MOTOGUZZI			
GRISO	2006-2015	01-F161	01-DC801

MODELLO	ANNI	CODICE FRENO	CODICE FRIZIONE
BREVA	2004-2009	01-F161	01-D371
BREVA 1100	2006-2012	01-F161	01-DC801
NORGE 1200/GT8V	2006-2015	01-F161	01-DC801
1200 SPORT	2007-2013	01-F161	01-DC801
STELVIO	2008-2015	01-F161	01-DC801
CALIFORNIA CUSTOM/ TOURING/CLASSIC	2014-2015	01-F231	01-C231
ELDORADO	2015	01-F231	01-C231
AUDACE	2015	01-F231	01-C231
V7 RACER	2011-2015	01-F161	01-D371
V7 CLASSIC	2008-2015	01-F161	01-D371
V7 STONE/SPECIAL	2013-2015	01-F161	01-D371
MV AGUSTA			
F4RR	2011-2016	01-F111	01-H111
MZ			
1000 S	2004-2008	01-F141	01-S141
1000 SF	2005-2008	01-F141	01-C7771
1000 ST	2006-2008	01-F141	01-C7771
SUZUKI			
RGV 250 GAMMA		01-F141	01-S6501
GSR600	2006-2011	01-F141	01-S2481
GSXR600	1997-2003	01-F141	01-S2481
GSXR600	2004-2005	01-F351	01-S2481
GSXR600	2006-2010	01-F351	01-S351
GSXR600	2011-2018	01-F351	01-S351
GSF650 BANDIT	-2007	01-F141	01-S141
SV650/S	1999-2009	01-F141	01-S6501
SFV650 GLADIUS	2009-2015	01-F141	01-S2481
DL650V-STROM	2004-2010	01-F141	01-S6501
DL650V-STROM	2011-2012	01-F141	01-S2481
SV 650 XA/A	2018-2019	01-F141	01-S2481
GSX650F	2008-2015	01-F141	01-S141
BANDIT 650S	2015	01-F141	01-S141
600/750 KATANA	1998-2006	01-F141	01-S6501
GSR750	2011-2015	01-F141	01-S2481
GSXR750	1996-2003	01-F141	01-S2481
GSXR750	2004-2005	01-F351	01-S2481
GSXR750	2006-2010	01-F351	01-S351
GSXR750	2011-2018	01-F351	01-S351
GSX S 750	2018-2019	01-F141	01-S2481
GSX-S 1000/F/ABS	2017-2019	01-F351	01-S351
GSXR1000	2001-2004	01-F141	01-S2481
GSXR1000	2005-2006	01-F351	01-S351
GSXR1000	2007-2008	01-F351	01-S141
GSXR1000	2009-2015	01-F351	01-S351

APPLICATIVO LEVE "SYNCRO"

MODELLO	ANNI	CODICE FRENO	CODICE FRIZIONE
GSXR1000	2017-2019	01-F351	01-S351
GSX-S 1000/F/ABS	2015	01-F351	01-S351
DL1000/V-STROM	2002-2016	01-F141	01-S141
TL1000S	1997-2001	01-F141	01-S2481
TL1000R	1998-2003	01-F141	01-S141
SV1000/S	2003-2007	01-F141	01-S141
KATANA 1000	2018-2019	01-F351	01-S351
GSF1200 BANDIT	2001-2006	01-F141	01-S141
GSF1250 BANDIT	2007-2015	01-F141	01-S141
GSX1250 F/SA/ABS	2010-2015	01-F141	01-S141
HAYABUSA/GSXR1300	1999-2007	01-F141	01-S141
HAYABUSA/GSXR1300	2008-2015	01-F401	01-S141
B-KING	2008-2011	01-F351	01-S311
GSX1400	2001-2007	01-F141	01-S141
TRIUMPH			
TT 600	2000-2003	01-F141	01-T9551
DAYTONA 600/650	2004-2005	01-F141	01-T3331
675 STREET TRIPLE	2008-2015	01-F141	01-T3331
675 STREET TRIPLE / R/RX	2009-2016	01-F351	01-T3331
DAYTONA 675	2006-2015	01-F351	01-T3331
DAYTONA 675 R	2011-2016	01-F011	01-T3331
DAYTONA 955I	1997-2003	01-F141	01-T9551
DAYTONA 955I	2004-2006	01-F141	01-T3331
SPRINT ST	1997-2003	01-F141	01-T9551
SPRINT RS	1999-2003	01-F141	01-T9551
SPEED FOUR	2003-2004	01-F141	01-T9551
SPEED FOUR	2005-2006	01-F141	01-T3331
SPEED TRIPLE	1997-2003	01-F141	01-T9551
SPEED TRIPLE	2004-2007	01-F141	01-T3331
SPEED TRIPLE	2008-2010	01-F351	01-T3331
SPEED TRIPLE 1050	2011-2015	01-F011	01-T3331
SPEED TRIPLE R	2012-2016	01-F011	01-T3331
SPRINT ST/RS	2004-2009	01-F141	01-T3331
SPRINT GT	2011-2015	01-F141	01-T3331
THRUXTON	2004-2015	01-F141	01-T3331
THRUXTON STEVE MCQUEEN SE	2012	01-F141	01-T3331
BONNEVILLE /SE/T100	2006-2015	01-F141	01-T3331
TIGER 800/XC	2011-2014	01-F141	01-T3331
TIGER 1050/SPORT	2007-2015	01-F141	01-T3331
TIGER 1200 EXPLORER	2012-2015	01-F141	01-C7771
ROCKET III	2004-2007	01-F141	01-T3331
ROCKET III CLASSIC	2007-2010	01-F141	01-T3331
ROCKET III ROADSTER	2010-2015	01-F141	01-T3331
SCRAMBLER	2006-2015	01-F141	01-T3331

MODELLO	ANNI	CODICE FRENO	CODICE FRIZIONE
SPEEDMASTER	2006-2015	01-F141	01-T3331
TROPHY/SE	2013-2015	01-F141	01-C7771
AMERICA/LT	2006-2015	01-F141	01-T3331
YAMAHA			
T-MAX 530	2012-2016	01-H531R	01-H531L
V-MAX	2009-2015	01-R1041	01-C7771
YZF R6	1999-2004	01-F141	01-Y6881
YZF R6	2005-2016	01-R1041	01-Y6881
R6S (USA VERSION)	2006-2009	01-F141	01-Y6881
R6S (CANADIAN VERSION)	-2006	01-R1041	01-Y6881
R6S (CANADIAN VERSION)	2007-2009	01-F141	01-Y6881
R6S (EUROPEAN VERSION)	2006-2007	01-R1041	01-Y6881
FZ6 FAZER	2004-2010	01-F161	01-Y6881
FZ6R	2009-2015	01-F161	01-Y6881
MT-07/FZ-07	2014-2016	01-F161	01-Y6881
MT07 TRACER	2016-2019	01-F161	01-Y6881
XSR 700	2016-2019	01-F161	01-Y6881
FZ 8	2011-2015	01-F161	01-Y6881
MT-09/SR/FZ-9	2014-2015	01-F161	01-Y6881
MT09 TRACER	2015-2017	01-F161	01-Y6881
MT09 TRACER/GT/SP/ABS	2018-2019	01-F161	01-Y6881
FJ-09	2015	01-F161	01-S351
TDM 900	2012-2014	01-F161	01-Y6951
YZF R1	1999-2001	01-F201	01-Y6881
YZF R1	2002-2003	01-F141	01-Y6881
YZF R1	2004-2008	01-R1041	01-Y6881
YZF R1	2009-2014	01-R191	01-Y6881
YZF R1 / R1M	2015-2019	01-R151	01-Y6881
YZF R1 / R1M	2020	01-R151	01-Y6881
FZ1 FAZER	2001-2005	01-F141	01-Y6881
FZ1 FAZER	2006-2013	01-F161	01-Y6881
FJR 1300	2003	01-F141	01-C7771
FJR 1300	2004-2015	01-F161	01-C7771
XJR 1300	2004-2015	01-F161	01-C7771
MT-01	2004-2009	01-R1041	01-C7771
XJ6 DIVERSION	2009-2015	01-F161	01-Y6881
SUPERTENERE/XT1200ZE	2012-2015	01-F161	01-C7771

LEVE "OFF-ROAD" A RICAMBIO

APPLICATIVO MOTO A SEGUIRE

LEVA FRIZIONE HONDA CR125R/CR250RT/V

01-C0010 Alluminio lucido



LEVA FRIZIONE HONDA CR250/CRF250/450

01-C0020 Alluminio lucido



LEVA FRIZIONE HONDA CRF250/450F 2007-2009

01-C0030 Alluminio lucido



LEVA FRIZIONE KAWASAKI KX

01-C0040 Alluminio lucido



LEVA FRIZIONE KAWASAKI KX 250 2005-2006

01-C0050 Alluminio lucido



LEVA FRIZIONE KTM 2 STROKE

01-C0060 Alluminio lucido



LEVA FRIZIONE KTM SX65 2002-2003

01-C0070 Alluminio lucido



LEVA FRIZIONE KTM EXC 2T/450SX 2009

01-C0080 Alluminio lucido



LEVA FRIZIONE KTM 250EXC/300EXC 2006/2007

01-C0090 Alluminio lucido



FORGIATA

Aggiornamenti sul sito www.forbikes.it

È vietato l'utilizzo su strada pubblica degli articoli non omologati.

FORBIKES
COMPONENTI PER MOTOCICLI

LEVA FRIZIONE SUZUKI RM125

01-C0100 Alluminio lucido



**LEVA FRIZIONE YAMAHA
YZ125/250/RM SUZUKI**

01-C0110 Alluminio lucido



**LEVA FRIZIONE 2000
YAMAHA LUNGA**

01-C0120 Alluminio lucido



**LEVA FRIZIONE YAMAHA
YZ/WR 2001-2002**

01-C0130 Alluminio lucido



**LEVA FRIZIONE
YAMAHA YZF250/450 2009**

01-C0140 Alluminio lucido



**LEVA FRIZIONE YAMAHA
WR250 2008-2009**

01-C0150 Alluminio lucido



**LEVA FRIZIONE YAMAHA
WR450/250 2003**

01-C0160 Alluminio lucido



**LEVA FRIZIONE KAWASAKI
KDX200 1983-2008**

01-C0170 Alluminio lucido



**COLLARINO E LEVA FRIZIONE
RIBALTABILE C/HOT STARTER**

01-0151 Universale



LEVE "OFF-ROAD" A RICAMBIO

LEVA FRENO HONDA KAWASAKI
CR125/250/500
KX125/250 1993-1994

01-B0010 Alluminio lucido



LEVA FRENO HONDA
CRF250/450F 2007-2009

01-B0020 Alluminio lucido



LEVA FRENO KAWASAKI KX125

01-B0030 Alluminio lucido



LEVA FRENO KAWASAKI
XR125/250 1997

01-B0040 Alluminio lucido



LEVA FRENO KAWASAKI
KX85/125/250 2000, YZ 2001

01-B0050 Alluminio lucido



LEVA FRENO YAMAHA
YZF250 2007

01-B0070 Alluminio lucido



LEVA FRENO KTM CORTA

01-B0080 Alluminio lucido



LEVA FRENO KTM
65/85 2004-2012

01-B0090 Alluminio lucido



LEVA FRENO KTM

01-B0100 Alluminio lucido



LEVA FRENO KTM
125/250/400 SX250 EXC 30/38

01-B0110 Alluminio lucido



LEVA FRENO DIA CASTING
KTM SXF250/450 2014

01-B0120 Alluminio lucido



LEVA FRENO SUZUKI
RM 1985-1995

01-B0130 Alluminio lucido



FORGIATA

LEVA FRENO SUZUKI RM125

01-B0141 Alluminio nero



LEVA FRENO YAMAHA YZ90-95

01-B0150 Alluminio lucido



LEVA FRENO YAMAHA
YZ125/250 1996

01-B0160 Alluminio lucido



LEVA FRENO YAMAHA WRF450 2012

01-B0180 Alluminio lucido



LEVA FRENO YAMAHA YZ85/125/250/450

01-B0190 Alluminio lucido



BRACCIALE FRIZIONE HONDA CR

01-H0010



**BRACCIALE FRIZIONE HONDA
CRF 150 4T CON LEVETTA
DECOMPRESSORE**

01-H0020



**BRACCIALE FRIZIONE HONDA
CR125-250 2004-2008, C/CUFFIA
PARAPOLVERE E REGISTRO RAPIDO**

01-H0030



**BRACCIALE FRIZIONE 4T HONDA
CRF 250/450 CON LEVETTA
DECOMPRESSORE**

01-H0040



**BRACCIALE FRIZIONE
KAWASAKI KX125/250**

01-H0050 Alluminio lucido



**BRACCIALE FRIZIONE KAWASAKI
KX250 2005-2006 C/CUFFIA
PARAPOLVERE E REGISTRO RAPIDO**

01-H0060 Alluminio lucido



**BRACCIALE FRIZIONE 4T KAWASAKI
KX250F 2005-2006 CON LEVETTA
DECOMPRESSORE**

01-H0070

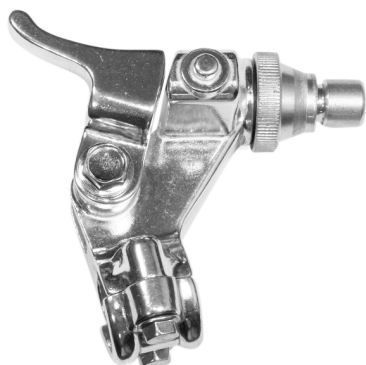

BRACCIALE FRIZIONE SUZUKI

01-H0080 Alluminio lucido



BRACCIALE FRIZIONE SUZUKI

01-H0090 Alluminio lucido



**BRACCIALE FRIZIONE 4T SUZUKI
RMZ450 2005-2006 CON LEVETTA
DECOMPRESSORE**

01-H0100



BRACCIALE FRIZIONE YZ E RM

01-H0110 Alluminio lucido



**BRACCIALE FRIZIONE YAMAHA
YZ 2000-2003**

01-H0120 Alluminio lucido



**BRACCIALE FRIZIONE YAMAHA
WRF250/450 2008-2009 CON
LEVETTA DECOMPRESSORE**

01-H0130



**BRACCIALE FRIZIONE YAMAHA
YZF250/450 2009 CON LEVETTA
DECOMPRESSORE E CUFFIA
PARAPOLVERE/REGISTRO RAPIDO**

01-H0140 Alluminio lucido



**BRACCIALE FRIZIONE 4T KAWASAKI
KX250F 2004 CON LEVETTA
DECOMPRESSORE**

01-H0150 Alluminio lucido



APPLICATIVO LEVE "OFF-ROAD" A RICAMBIO

CILINDRATA	MODELLO	ANNI	LEVA FRIZIONE	LEVA FRENO	BRACCIALE FRIZIONE
HONDA					
80	CR	1996-1997	01-C0010	01-B0010	01-H0010
85	CR	2003-2007	01-C0010	01-B0010	01-H0010
125	CR	1992-2003	01-C0010	01-B0010	01-H0010
125	CR	2004-2014	01-C0020	01-B0010	01-H0030
150	CRF	2007-2018	01-C0010	01-B0010	01-H0020
250	CR	1992-2003	01-C0010	01-B0010	01-H0010
250	CR	2004-2014	01-C0020	01-B0010	01-H0030
450	CRF	2002-2003	01-C0010	01-B0010	01-H0020
450	CRF	2004-2006	01-C0020	01-B0010	01-H0040
500	CR	1992-2002	01-C0010	01-B0010	01-H0010
250R	CRF	2004-2006	01-C0020	01-B0010	01-H0040
250R	CRF	2007-2017	01-C0030	01-B0020	01-H0040
450R	CRF	2007-2018	01-C0030	01-B0020	01-H0040
KAWASAKI					
80	KX	1994-1996	01-C0170	01-B0030	01-H0050
80	KX	1997	01-C0170	01-B0040	01-H0050
80	KX	1998-2000	01-C0040	01-B0040	
85	KX	2001-2018	01-C0040	01-B0050	01-H0050
125	KX	1993-1996	01-C0040	01-B0030	01-H0050
125	KX	1997-1999	01-C0040	01-B0040	01-H0050
125	KX	2000-2005	01-C0040	01-B0050	01-H0050
125	KX	2006-2009	01-C0050	01-B0050	
250	KX	1993-1996	01-C0040	01-B0030	01-H0050
250	KX	1997-1999	01-C0040	01-B0040	01-H0050
250	KX	2000-2004	01-C0040	01-B0050	01-H0050
250	KX	2005-2009	01-C0050	01-B0050	01-H0050
250	KXF	2004	01-C0040	01-B0050	01-H0060
250	KXF	2005-2012	01-C0050	01-B0050	01-H0070
250	KXF	2013-2018	01-C0050	01-B0070	01-H0070
450	KXF	2006-2012	01-C0050	01-B0050	01-H0070
450	KXF	2013-2018	01-C0050	01-B0070	01-H0060
500	KX	1993-1996	01-C0040	01-B0030	01-H0050
500	KX	1997-1999	01-C0040	01-B0040	01-H0050
500	KX	2000-2008	01-C0040	01-B0050	01-H0050
KTM					
65	SX	2002-2003	01-C0070	01-B0080	
65	SX	2004-2011	01-C0060	01-B0090	
65	SX	2012-2013	01-C0060		
85	SX	2004-2012	01-C0060	01-B0090	
125	EXC	1998-1999	01-C0070	01-B0100	
125	EXC	2000-2003	01-C0070	01-B0080	
125	EXC	2004	01-C0060	01-B0080	
125	EXC	2005-2008	01-C0060	01-B0110	
125	SX	1998-1999	01-C0070	01-B0100	

APPLICATIVO LEVE "OFF-ROAD" A RICAMBIO

CILINDRATA	MODELLO	ANNI	LEVA FRIZIONE	LEVA FRENO	BRACCIALE FRIZIONE
125	SX	2000-2003	01-C0070	01-B0080	
125	SX	2004	01-C0060	01-B0080	
125	SX	2005-2008	01-C0060	01-B0110	
125	SX	2009-2013	01-C0080	01-B0110	
125	SX	2014-2018	01-C0080	01-B0120	
144	SX	2008	01-C0060	01-B0110	
150	SX	2009-2013	01-C0080	01-B0110	
150	SX	2014-2018	01-C0080	01-B0120	
200	EXC	2005-2008	01-C0060	01-B0110	
250	EXC	2000-2002	01-C0070	01-B0080	
250	EXC	2003-2004	01-C0060	01-B0080	
250	EXC	2005	01-C0060	01-B0110	
250	EXC	2006-2008	01-C0090	01-B0110	
250	EXC	2009-2018	01-C0090	01-B0110	
250	EXC-F	2006-2018	01-C0090	01-B0110	
250	SX	2000-2002	01-C0070	01-B0080	
250	SX	2003-2004	01-C0060	01-B0080	
250	SX	2005	01-C0060	01-B0110	
250	SX	2006-2008	01-C0090	01-B0110	
250	SX	2009-2013	01-C0090	01-B0110	
250	SX	2014-2018	01-C0090	01-B0120	
250	SX-F	2006	01-C0060	01-B0110	
250	SX-F	2007-2013	01-C0090	01-B0110	
250	SX-F	2014-2018	01-C0090	01-B0120	
300	EXC	2005	01-C0060	01-B0110	
300	EXC	2006-2018	01-C0090	01-B0110	
350	EXC-F	2012-2018	01-C0090	01-B0110	
350	SX-F	2011-2013	01-C0090	01-B0110	
350	SX-F	2014-2018	01-C0090	01-B0120	
380	EXC	2000-2002	01-C0070	01-B0080	
450	EXC-F	2003-2004	01-C0060	01-B0080	
450	EXC-F	2005-2007	01-C0060	01-B0110	
450	EXC-F	2008-2013	01-C0090	01-B0110	
450	SX-F	2003-2004	01-C0060	01-B0080	
450	SX-F	2005-2008	01-C0060	01-B0110	
450	SX-F	2009-2013	01-C0080	01-B0110	
450	SX-F	2014-2018	01-C0090	01-B0120	
520	EXC-F	2000-2002	01-C0070	01-B0080	
520	SX-F	2000-2002	01-C0070	01-B0080	
525	EXC-F	2003-2004	01-C0060	01-B0080	
525	EXC-F	2005-2007	01-C0060	01-B0110	
525	SX-F	2003-2004	01-C0060	01-B0080	
530	EXC-F	2008-2013	01-C0090	01-B0110	
SUZUKI					
125	RM	1987-1995	01-C0100	01-B0130	01-H0080

APPLICATIVO LEVE "OFF-ROAD" A RICAMBIO

CILINDRATA	MODELLO	ANNI	LEVA FRIZIONE	LEVA FRENO	BRACCIALE FRIZIONE
125	RM	1996-2003	01-C0100	01-B0140	01-H0080
125	RM	2004-2009	01-C0100	01-B0050	01-H0090
250	RM	1987-1995	01-C0100	01-B0130	01-H0080
250	RM	1996-2003	01-C0100	01-B0140	01-H0080
250	RM	2004-2009	01-C0100	01-B0050	01-H0090
250	RMZ	2004	01-C0040	01-B0050	01-H0150
250	RMZ	2005-2006	01-C0050	01-B0050	01-H0070
250	RMZ	2007-2017	01-C0040	01-B0050	01-H0100
450	RMZ	2005-2017	01-C0040	01-B0050	01-H0100
YAMAHA					
85	YZ	2002-2014	01-C0110	01-B0190	01-H0110
85	YZ	2015-2018	01-C0140	01-B0070	
125	YZ	1992-1995	01-C0110	01-B0150	01-H0110
125	YZ	1996-1999	01-C0110	01-B0160	01-H0110
125	YZ	2000	01-C0120	01-B0160	01-H0120
125	YZ	2001-2007	01-C0120	01-B0190	01-H0120
125	YZ	2008-2014	01-C0120	01-B0070	01-H0120
125	YZ	2015-2018	01-C0140	01-B0070	
250	WRF	2003-2006	01-C0160	01-B0190	
250	WRF	2007	01-C0120	01-B0190	01-H0130
250	WRF	2008-2018	01-C0150	01-B0190	01-H0130
250	YZ	1992-1995	01-C0110	01-B0150	01-H0110
250	YZ	1996-1999	01-C0110	01-B0160	01-H0110
250	YZ	2000	01-C0120	01-B0160	01-H0120
250	YZ	2001-2007	01-C0120	01-B0190	01-H0120
250	YZ	2008-2014	01-C0120	01-B0070	01-H0120
250	YZF	2001-2006	01-C0120	01-B0190	01-H0120
250	YZF	2007-2008	01-C0120	01-B0070	01-H0120
250	YZF	2009-2018	01-C0140	01-B0070	01-H0140
400	WRF	1998-1999	01-C0110	01-B0160	01-H0110
400	YZF	1998-1999	01-C0110	01-B0160	01-H0110
426	WRF	2000-2002	01-C0110	01-B0160	01-H0120
426	YZF	2000-2002	01-C0110	01-B0160	01-H0120
450	WRF	2003-2006	01-C0160	01-B0190	
450	WRF	2008-2011	01-C0150	01-B0190	01-H0130
450	WRF	2012-2018	01-C0150	01-B0180	01-H0130
450	YZF	2003-2007	01-C0120	01-B0190	01-H0120
450	YZF	2008	01-C0120	01-B0070	01-H0120
450	YZF	2009-2018	01-C0140	01-B0070	01-H0140

COPPIA MANOPOLE "CROSS" L.115 MM

09-0081 Nero

09-0083 Blu

09-0084 Rosso

09-0088 Verde



CP.MANOPOLE SPORT L.115 MM

09-0101 Nero



COPPIA MANOPOLE OFF-ROAD "GUM"

09-0131 Nero-grigio

09-0134 Rosso-grigio

09-0135 Giallo-grigio

09-0137 Arancio-grigio

09-0138 Verde-grigio



CP.MANOPOLE GRIPPY GRIP GGD-BASE, FINALE APERTO

88217 Nero

88218 Grigio

88219 Marrone



DAYTONA

CP.MANOPOLE GRIPPY GRIP GGD-NAMI, FINALE APERTO

88561 Nero

88562 Marrone

88563 Rosso scuro



DAYTONA

COPPIA MANOPOLE GRIPPY GRIP GGD-DELTA, FINALE APERTO

- 88565 Nero
- 88566 Marrone
- 88567 Rosso scuro
- 88568 Tipo gomma



COPPIA MANOPOLE GRIPPY GRIP GGD-AMI, FINALE APERTO

- 88569 Nero
- 88570 Marrone
- 88571 Rosso scuro
- 88613 Grigio
- 88614 Blu scuro
- 88615 Verde scuro



COPPIA MANOPOLE GRIPPY GRIP GGD-KATANA, FINALE APERTO

- 88573 Rosso
- 88574 Blu
- 88575 Verde
- 88576 Grigio
- 88579 Bianco

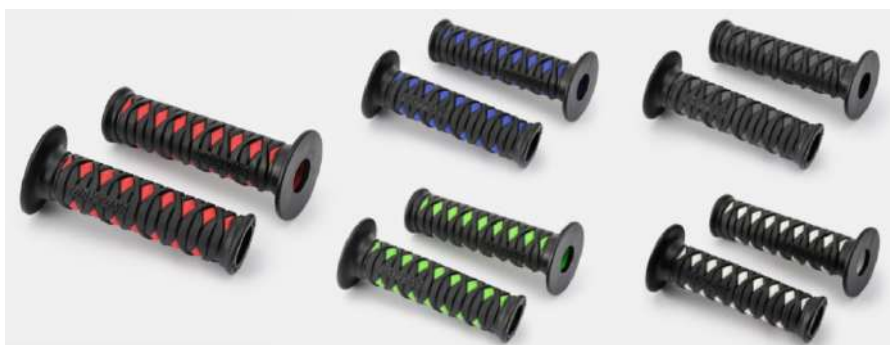

COPPIA MANOPOLE GRIPPY GRIP GGD-NINJA, FINALE APERTO

- 88663 Nero
- 88664 Grigio
- 88665 Marrone
- 88666 Rosso scuro



COPPIA MANOPOLE GRIPPY GRIP GGD-LINE, FINALE APERTO

- 88658 Rosso
- 88659 Blu
- 88660 Verde
- 88661 Giallo
- 88769 Grigio



COPPIA MANOPOLE GRIPPY GRIP GGDI-ARC I, FINALE CHIUSO

- 88667 Nero, manubri 25,4 mm



COPPIA MANOPOLE GRIPPY GRIP GGDI-OCTA, FINALE CHIUSO

- 88674 Nero, manubri 25,4 mm



COPPIA MANOPOLE GRIPPY GRIP GGDI-ARC III, FINALE CHIUSO

- 88675 Nero, manubri 25,4 mm



COPPIA MANOPOLE GRIPPY GRIP GGD-KANI, FINALE APERTO

- 88937 Nero
- 88938 Grigio
- 88939 Marrone
- 88940 Caramello



COPPIA MANOPOLE GRIPPY GRIP GGD-CELL, FINALE APERTO

- 88669 Rosso
- 88670 Blu
- 88671 Verde
- 88672 Grigio
- 88673 Verde scuro



COPPIA MANOPOLE GRIPPY GRIP GGD-SAKURA, FINALE APERTO

- 88942 Nero
- 88943 Grigio
- 88944 Caramello
- 88945 Rosa
- 88946 Bianco





MANOPOLE RISCALDATE

KIT MANOPOLE RISCALDATE PER MANUBRI 22,2 MM, INTERRUTTORE INTEGRATO

89820 Con spie e spegnimento automatico



Protezione della batteria con spegnimento automatico se il voltaggio è inferiore a 12V



Per manubri 22,2 mm
 Terminale aperto, lunghezza 120 mm
 4 livelli di controllo del calore
 5 spie LED
 Waterproof, 12 Volt (DC)



ARANCIO
 Livello 4
 35W



GIALLO
 Livello 3
 32W

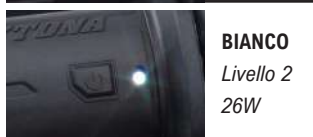

BIANCO
 Livello 2
 26W



BLU
 Livello 1
 19W



ROSSO
 All'avvio

88640 Con spie



KIT MANOPOLE RISCALDATE, CONTROLLO ELETTRICO

86607 Manubri 22,2 mm terminale chiuso

86610 Manubri 25,4 mm, terminale chiuso

86608 ATV, terminale chiuso

86607
 86608



86610



KIT MANOPOLE RISCALDATE CON LEVA DI COMANDO INTEGRATA

88019 Manubri 25,4 mm terminale chiuso

88020 Harley Davidson (96UP, 08UP) terminale chiuso

Con interruttore
3 livelli di controllo del calore
SX 134 mm, DX 125 mm
Waterproof

88019

88020



PANNETTO RISCALDANTE PER MANOPOLE 12V

80583 Con interruttore ON/OFF

NEW



Dimensioni: 105x95 mm
Dotato di interruttore ON/OFF
Si monta facilmente sulle manopole

COPPIA STABILIZZATORI MANUBRIO LISCIO ALLUMINIO 17 MM

12-0020	Lucidi
12-0021	Nero
12-0023	Blu
12-0024	Rosso
12-0025	Oro
12-0029	Carbon



COPPIA STABILIZZATORI MANUBRIO ZIGRINATI ALLUMINIO 17 MM

12-0050	Lucidi
12-0051	Nero
12-0053	Blu
12-0054	Rosso
12-0055	Oro
12-0059	Carbon



COPPIA STABILIZZATORI MANUBRIO ZIGRINATI ALLUMINIO 13 MM

12-0060	Lucidi
12-0061	Nero
12-0063	Blu
12-0064	Rosso
12-0065	Oro
12-0069	Carbon



COPPIA TERMINALI MANUBRIO ANODIZZATI "TKM-2"

- 87331 Nero-rosso
- 87332 Nero-blu
- 87333 Nero-oro
- 87334 Nero-verde
- 87335 Nero-argento
- 87336 Nero-nero
- 88059 Nero-arancione

NEW



COPPIA TERMINALI MANUBRIO CNC "BULLET"

- 98369 Rosso
- 98370 Blu
- 98371 Oro
- 98372 Verde
- 98373 Argento
- 98374 Nero

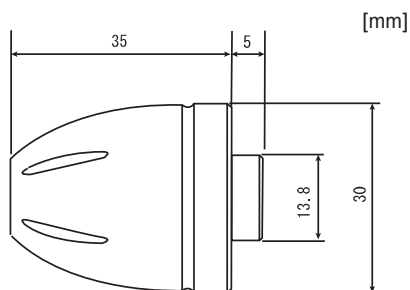

COPPIA TERMINALI MANUBRIO CNC "AERO"

99914	Rosso
99915	Blu
99916	Champagne
99917	Verde
99918	Argento
99919	Nero

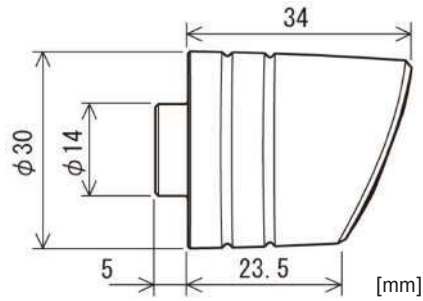

COPPIA TERMINALI MANUBRIO CNC "CANARD"

99920	Rosso
99921	Blu
99922	Champagne
99923	Verde
99924	Argento
99925	Nero

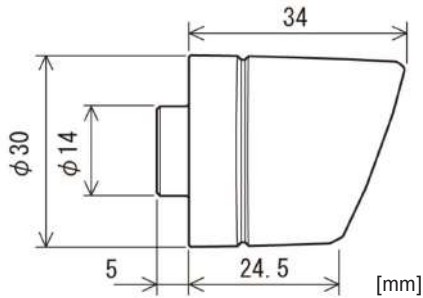

**COPPIA SPECCHIETTI
UNIVERSALI (NO ATTACCO BMW)**

NEW

05-0211 Neri



PERSONALIZZABILE

E-MARKED

**SPECCHIETTO UNIVERSALE
TONDO DX/SX RECLINABILE**

NEW

05-0221 Nero



PERSONALIZZABILE

E-MARKED

**SPECCHIETTO "D-MIRROR-2"
NERO**

88610 Lato sinistro

88611 Lato destro



SPECCHIETTO BAR-END A MANUBRIO IN ALLUMINIO "D-MIRROR" NERO

89428

89430

89474

Specchietto singolo lato destro o sinistro
(acquistarne 2 per moto)
Semplice e minimale e realizzato in alluminio
Comprende un anello manubri 22,2 mm e un
anello per manubri 25,4 mm



89428



89430



89474



E-MARKED

DAYTONA



SPECCHIETTO IN ALLUMINIO "ROD" NERO

89429

89431

89475

Specchietto singolo lato destro o sinistro
(acquistarne 2 per moto)
Incluse viti M10 x P1.25
Realizzato in alluminio



89429



89431



89475



E-MARKED

DAYTONA



COPPIA SPECCHIETTO BAR-END A MANUBRIO

89813 Corto

89814 Lungo

Corpo in ABS e gambo in alluminio
Include due distanziali (22,2 e 25,4 mm) per il
montaggio sul manubrio
Diametro interno morsetto: 30 mm

NEW



89813



89814



E-MARKED

DAYTONA

NEW

COPPIA SPECCHIETTO BAR-END A MANUBRIO

- 89816** Corto

- 89817** Lungo

Corpo in ABS e gambo in alluminio
 Include due distanziali (22,2 e 25,4 mm) per il
 montaggio sul manubrio
 Diametro interno morsetto: 30 mm



89816



89817



E-MARKED



COPPIA SPECCHIETTO DESTRA/SINISTRA

- 89815**

- 89818**

Corpo in ABS e gambo in acciaio
 Include 3 adattatori (1 SX / 2 DX)

89815

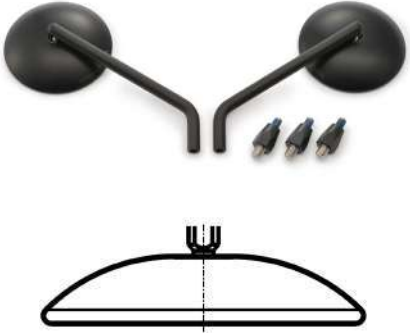

89818

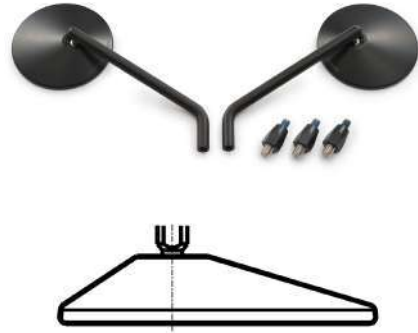

E-MARKED

NEW



ADATTATORI SPECCHIETTI BAR-END A MANUBRIO

89440	Universali
89441	Yamaha 1
89442	Yamaha 2
89443	Suzuki
89444	Kawasaki



DAYTONA

SUPPORTO SPECCHIO A MANUBRIO ALLUMINIO 10 MM

05-0080	Cromato
05-0081	Nero



140x220x90 mm

SUPPORTO SPECCHIO A MANUBRIO, AVANZATO 10 MM

05-0200	Cromato
05-0201	Nero



ESTENSIONE PER SPECCHIETTO RETROVISORE 10 MM, NERO

05-0181	Sinistro
05-0191	Destro



COPRIFORO SPECCHIETTO M10 X P1,25 ANODIZZATO

99614	Destro	Argento
99615	Sinistro	Argento
99616	Destro	Nero
99617	Sinistro	Nero
99618	Destro	Titanio
99619	Sinistro	Titanio
99794	Destro	Rosso
99795	Sinistro	Rosso
99796	Destro	Blu
99797	Sinistro	Blu
99798	Destro	Oro
99799	Sinistro	Oro
99800	Destro	Verde
99801	Sinistro	Verde



NEW

DAYTONA

**INTERRUTTORE SPEGNIMENTO
MOTORE KAWASAKI CROSS**

13-0010



**INTERRUTTORE SPEGNIMENTO
MOTORE YAMAHA CROSS/ENDURO**

13-0020



**INTERRUTTORE A MANUBRIO
UNIVERSALE ON-OFF**

13-0030



**INTERRUTTORE A MANUBRIO
UNIVERSALE ACCENSIONE LUCI
SUPPLEMENTARI**

13-0040



**INTERRUTTORE A MANUBRIO
UNIVERSALE RUN / OFF +
AVVIAMENTO MOTORE**

13-0050



**INTERRUTTORE DI SICUREZZA A
STRAPPO FISSAGGIO A MANUBRIO**

13-0060



**INTERRUTTORE DI SICUREZZA A
STRAPPO FISSAGGIO A TELAIO**

13-0070



**INTERRUTTORE SPEGNIMENTO
SUZUKI CROSS**

13-0120



**INTERRUTTORE A MANUBRIO UNIV.
ACCENSIONE LUCI, INDICATORI
DIREZIONE, CLACSON**

13-0190



INTERRUTTORE A MANUBRIO AVVIAMENTO

13-0220 Tipo Honda CRF250/450



CONTAORE MOTORE ELETTRONICO

13-0210



Wireless e resettabile
Waterproof IP68
Larghezza 68 mm, altezza 33 mm

INTERRUTTORE ON/OFF, FANALE ANTERIORE

71780 Nero

19172 Giallo

NEW



Per manubrio 22,2 mm
Dimensioni: 50x24x20 mm
Lunghezza filo: 1000 mm



INTERRUTTORE UNIVERSALE, PIATTO

71779 Nero

40440 Giallo

NEW



12V o 6V e max. 100W
Dimensioni: 20x35x17 mm
Lunghezza filo: 800 mm



INTERRUTTORE UNIVERSALE CNC PER STRUMENTI SERIE VELONA

87047 Nero

87082 Cromato



INTERRUTTORE ON-OFF "SLIM SWITCH"

88158 A bilanciere, tasti tondi

88159 A bilanciere

88160 Levetta piatta

88161 Levetta cilindrica

88162 A bilanciere per fanale H4

DC 12V / 15A (12V-180 W / 6V-90 W)
Per manubri con diametro 22,2 e 25,4 mm
Realizzato in Nylon

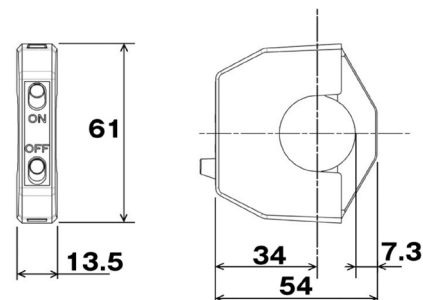

DAYTONA

STRUMENTO COMPATTO INDICATORI LED "ALPHA" ALLUMINIO CNC

86531 Nero

86532 Cromato



Corpo in ABS e morsetto in alluminio CNC
Dimensioni: 14x47x11,7 mm
Per manubri con diametro 22,2 e 25,4 mm

STRUMENTO COMPATTO INDICATORI LED "BETA" ALLUMINIO CNC

87467 Nero

87468 Cromato

87624 Argento



Corpo in alluminio CNC
Dimensioni: 46,8x13,8x11,5 mm
100% waterproof

DAYTONA

STRUMENTO COMPATTO RILEVAMENTO TEMPERATURA OLIO

89278 -9°C - 150°C



Temperatura inferiore a 50°C o superiore a 120°C segnalata dalla luce rossa
Waterproof (IPX7), display LCD con retroilluminazione a LED, include sensore R1/8
Larghezza x altezza x profondità: 42x25x10,8 mm



DAYTONA

Aggiornamenti sul sito www.forbikes.it

È vietato l'utilizzo su strada pubblica degli articoli non omologati.

FORBIKES
COMPONENTI PER MOTOCICLI

VOLTMETRO COMPATTO 7.5 - 18 V

89279



Meno di 12 Volt segnalati dalla luce rossa LED
Waterproof (IPX7), display LCD
Larghezza x altezza x profondità: 42x25x10,8 mm



FILO E SENSORE TEMPERATURA ACQUA / OLIO (CON TERMINALE)

80228



FILO SPIRALE AD INDUZIONE PER CAVO CANDELA + FILO COLLEGAMENTO A BOBINA

87170



KIT SENSORE DI VELOCITÀ E SUPPORTO, PROXIMITY TYPE

87038



CONVERTITORE SEGNALE DI VELOCITÀ

87041 Inserto diametro 18

87143 G2 - inserto diametro 15

87429 A2 - inserto diametro 12

87430 Da meccanico a elettrico

87755 Inserto diametro 10

88457 Per BMW

Trasforma il movimento meccanico in un segnale di impulso elettrico



**ADATTATORE DOPPIA PRESA USB
PER PRESA 12V FORO PICCOLO**

13-0110 Attacco diretto BMW e Triumph



Input 12-24V
Output 5V 2A
2 porte USB

**PRESA 5V/2A DOPPIA PORTA USB
A MANUBRIO**

13-0180



Impermeabile, cavo 120 cm
Input 12V-24V, Output 5V 2A
2 porte USB

**PRESA USB DOPPIA PORTA
3.1A 5V**

NEW

13-0250



Impermeabile
In ABS
2 porte USB

KIT PRESA USB A MANUBRIO SOTTILE

89371 1 porta

89372 2 porte

Per manubri con diametro 22,2 e 25,4 mm
Input: DC12V (DC10V-16V)
Output: DC5V (4.8-5.2 V)
Realizzato in resina ABS

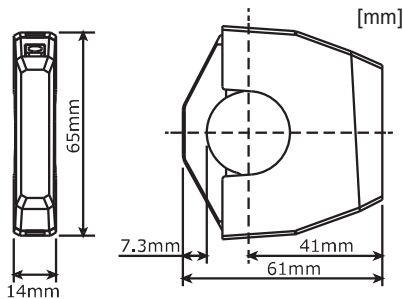

**KIT PRESA USB A MANUBRIO,
TIPO A**

NEW

80729 1 porta 2.4A

80730 2 porte 2.4A x 2



**KIT PRESA USB A MANUBRIO,
TIPO C**

NEW

80399 1 porta



**KIT PRESA USB A MANUBRIO
SOTTILE, TIPO C**

NEW

80400 1 porta



KIT PRESA USB A MANUBRIO

87237 1 porta

87238 2 porte

87239 1 porta con accendisigaro

87406 2 porte con accendisigaro

Input: Battery (DC12V)
Output: USB DC5V / 2.1A
Output: accendisigaro DC12V / 5A

87237



87238



87239



87406



DAYTONA

BARRA MULTIFUNZIONE CON PRESA USB

93380 Su cilindro principale, diam.100 mm

93381 Su rialzo, diam.100 mm

93382 Su stelo, diam.100 mm

93385 Su cilindro principale, diam.155 mm

93386 Su rialzo, diam.155 mm

93387 Su stelo, diam.155 mm

Input: DC12V

Output: DC5V / 2.1A

93380

93385



93381

93386



93382

93387



DAYTONA



SUPPORTO SMARTPHONE

87964 Tipo removibile con sgancio rapido



Larghezza regolabile 55 - 85 mm
Lunghezza regolabile 110 - 147 mm
Profondità 6 - 18 mm
Fino a 300 g di peso
Include morsetto per manubri 22 - 29 mm



SUPPORTO SMARTPHONE TIPO REMOVIBILE CON SGANCIO RAPIDO

80219



Larghezza regolabile 55 - 85 mm
Lunghezza regolabile 123 - 170 mm
Profondità 6 - 18 mm
Fino a 300 g di peso
Include morsetto per manubri 22 - 29 mm



SUPPORTO SMARTPHONE CON CUSTODIA

94944 Tg. M, tipo fisso con montaggio a vite

94945 Tg. M, tipo removibile con sgancio rapido

94805 Tg. XL, tipo fisso con montaggio a vite

94806 Tg. XL, tipo removibile con sgancio rapido

Taglia M: 137x70x20 mm
Taglia XL: 168x89x20 mm

Per manubri di diametro 22 - 29mm.
Rotazione dello smartphone di 360°.
Finestrella trasparente touch-screen.
Dotato di morsetto MINOURA che vanta un'ottima reputazione in termini di affidabilità.
Riduce al minimo le vibrazioni del telefono.
Protegge lo smartphone dagli schizzi di pioggia e dalla polvere.



Aggiornamenti sul sito www.forbikes.it

È vietato l'utilizzo su strada pubblica degli articoli non omologati.

FORBIKES
COMPONENTI PER MOTOCICLI



**CATADIOTTO POSTERIORE
RETTANGOLARE PER PORTATARGA**

00-0334



OMOLOGATO

9x3,2 cm

**FANALINO POSTERIORE A LED
UNIVERSALE "DAYTONA"**

02-0270 Trasparente



OMOLOGATO

**FANALINO POSTERIORE A LED
UNIVERSALE "MACAO"**

02-0320 Trasparente



Luce targa integrata

OMOLOGATO

**LUCE TARGA A LED RIVESTIMENTO
IN PLASTICA**

02-0591



PERSONALIZZABILE

OMOLOGATO

**FANALINO POSTERIORE A LED
OFF-ROAD/RACING IN ABS**

02-0781 Nero



85x54x20 mm

OMOLOGATO

**LUCE TARGA UNIVERSALE IN ABS
M4 X P0.7**

88857



Distanza viti: 24mm
14x49x19,8 mm

E-MARKED

DAYTONA

KIT 2 PEZZI FARETTO LED, INCLUSO CABLAGGIO PER 2 FARETTI

02-0741 Profondità (luce SPOT)

02-0751 Antinebbia (luce FLOOD)

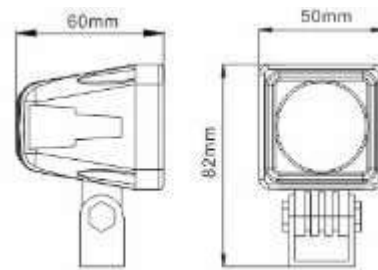

KIT 2 PEZZI SUPPORTO PER FARETTO A LED

02-0761 Diametro 22-26 mm

02-0771 Diametro 26-35 mm



CABLAGGIO ELETTRICO PER DUE FARETTI

04-0100 200 gr

NEW



FANALE ANTERIORE LED OLD STYLE "NEO VINTAGE" 5-3/4"

88431 Nero

88432 Cromato



E-MARKED



FANALE ANTERIORE OLD STYLE "VINTAGE"

86903	Destro	Nero
86904	Destro	Cromato
87357	Destro	Nero, cornice nera
86906	Sinistro	Nero
86907	Sinistro	Cromato
87800	Sinistro	Nero, cornice nera

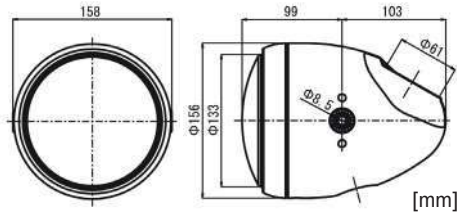

E-MARKED

FANALE ANTERIORE A LED "CAPSULE120"

88633	Montaggio laterale	Nero
88634	Montaggio laterale	Cromato
88635	Montaggio inferiore	Nero
88636	Montaggio inferiore	Cromato



MONTAGGIO LATERALE



MONTAGGIO INFERIORE

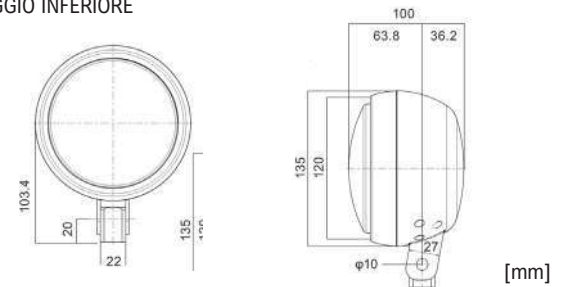
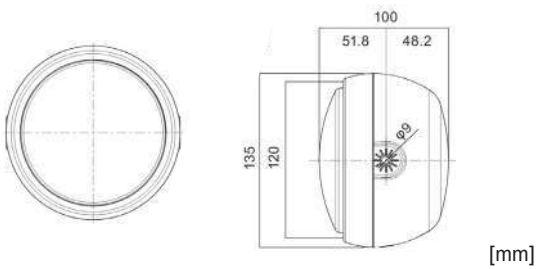

E-MARKED

DAYTONA

E-MARKED

DAYTONA

COPPIA STAFFE SUPPORTO FANALI IN CNC

88622	Lunga 55 mm	Diametro 35 mm
88623	Lunga 55 mm	Diametro 39 mm
88624	Lunga 55 mm	Diametro 41 mm
88625	Lunga 55 mm	Diametro 43 mm
88626	Lunga 55 mm	Diametro 49 mm
88617	Lunga 101,5 mm	Diametro 35 mm
88618	Lunga 101,5 mm	Diametro 39 mm
88619	Lunga 101,5 mm	Diametro 41 mm
88620	Lunga 101,5 mm	Diametro 43 mm
88621	Lunga 101,5 mm	Diametro 49 mm

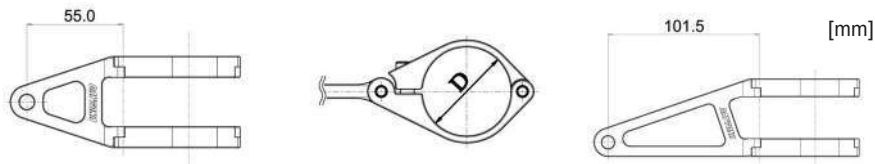

COPPIA STAFFE SUPPORTO FANALE ANTERIORE "VINTAGE"

86981	Diam. 35 mm	Acciaio nero
86909	Diam. 39 mm	Inox lucido
86941	Diam. 39 mm	Acciaio nero
86910	Diam. 41 mm	Inox lucido
86942	Diam. 41 mm	Acciaio nero





KIT TRASFORMAZIONE A LED PER LAMPADA H4

04-0070



KIT TRASFORMAZIONE A LED PER LAMPADA H1

04-0080



KIT TRASFORMAZIONE A LED PER LAMPADA H7

04-0090



KIT 10 PEZZI LAMPADINA ALOGENA 12V21W BAY9S PER MINI FRECCIE

04-0010 Trasparente

04-0017 Arancio



COPPIA MINI FRECCE A LAMPADINA "DOUBLE ARROW"

03-0021	Nero
03-0029	Carbon
03-0031	Nero gambo lungo
03-0039	Carbon gambo lungo



OMOLOGATE

COPPIA MINI FRECCE A LAMPADINA "FUEGO" DOPPIA LENTE

03-0081	Nero
03-0089	Carbon
03-0091	Nero gambo lungo
03-0099	Carbon gambo lungo



OMOLOGATE

COPPIA FRECCE A LED "DIRK" LENTE CHIARA

03-0211	Freccia - posizione
03-0221	Freccia - stop - posizione



OMOLOGATE

COPPIA MINI FRECCE A LED "PILL" VETRO FUMÈ

03-0251



OMOLOGATE

COPPIA MINI FRECCE A LED "RUNNER"

03-0261



OMOLOGATE

LUCE SEQUENZIALE

COPPIA MINI FRECCE A LED "SIOUX"

03-0271	Freccia - stop - posizione
---------	----------------------------



OMOLOGATE

COPPIA MINI FRECCE A LED IN ALLUMINIO

03-0291	Montaggio a specchietto M10
---------	-----------------------------



OMOLOGATE

COPPIA INDICATORI DIREZIONE ALLUMINIO LED "D-LIGHT"

86681	Corpo cromato	Lente chiara
86682	Corpo cromato	Lente fumè
86683	Corpo silver	Lente chiara
86684	Corpo silver	Lente fumè
89232	Corpo nero	Lente fumè

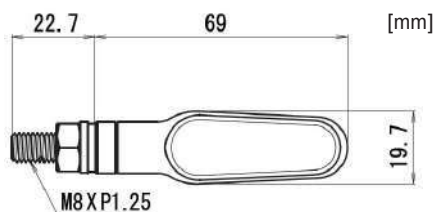

86681
86682



86683
86684



89232



DAYTONA

E-MARKED

COPPIA INDICATORI DIREZIONE ALLUMINIO LED "STELLAR"

88266 Nero



E-MARKED

LUCE SEQUENZIALE

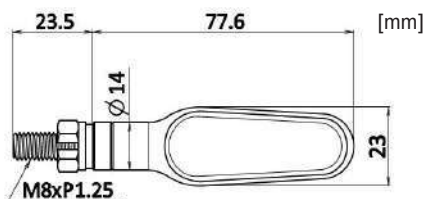

DAYTONA

COPPIA INDICATORI DIREZIONE ALLUMINIO LED "RAY" ANTERIORE/POSTERIORE

89273 Nero

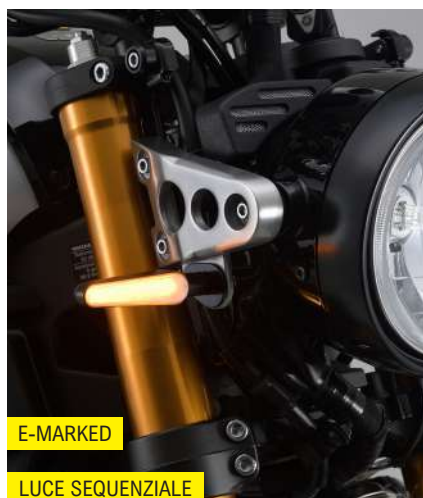

E-MARKED

LUCE SEQUENZIALE

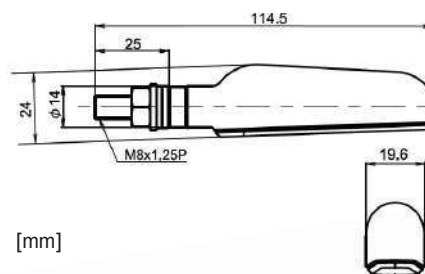

[mm]



DAYTONA

COPPIA INDICATORI DI DIREZIONE IN ALLUMINIO LED "D-LIGHT SOL"

88703 Lente arancio

88731 Lente fumè



E-MARKED



COPPIA INDICATORI DI DIREZIONE IN ALLUMINIO LED "D-LIGHT SOL-W", INDICATORE - STOP - POSIZIONE

89274 Lente arancio

89275 Lente fumè



E-MARKED

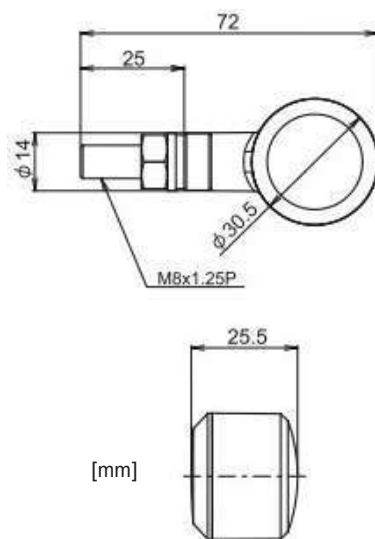

DAYTONA

KIT 2 PEZZI CONNETTORI DEDICATI PER MINIFRECCE

03-0160 Suzuki

03-0170 Yamaha



03-0160

03-0170



KIT 2 PEZZI CONNETTORI DEDICATI PER MINIFRECCE

03-0180 Honda-Kawasaki

03-0190 Honda



03-0180

03-0190



RESISTENZA PER INTERMITTENZA MINI FRECCHE A LED

04-0040



KIT 2 PEZZI RESISTENZA IN ALLUMINIO MINIFRECCE LED

04-0060 8.2 OHM



FLASH RELAY REGOLABILE CON TRIMMER

NEW

13-0230 0.1W-150W / 0.02A-20A



RELAY CON CONNETTORE CONVERTIBILE PER MINIFRECCE A LAMPADINA O LED

88985 0.1-100W / DC12V

38x28,4x17,5 mm

Frequenza di lampeggio: 85 al minuto



DAYTONA

RELAY CON CONNETTORE PER LUCI POSIZIONE / DIREZIONE

89460 0.1-100W / DC12V



38x28,4x17,5 mm

Frequenza di lampeggio:

85 al minuto

DAYTONA

RELAY CON CONNETTORE 8P PER HONDA CON LUCI POSIZIONE / DIREZIONE E LAMPEGGIO DI EMERGENZA

NEW

89658 0.1-100W / DC12V



Frequenza di lampeggio ESS: 220 lampeggi al minuto

Frequenza di lampeggio posizione/direzione: 85 al minuto



DAYTONA

ADATTATORI MINIFRECCE

00-0080 Universali



ADATTATORI MINIFRECCE

00-0090 Honda



ADATTATORI MINIFRECCE

00-0100 Kawasaki

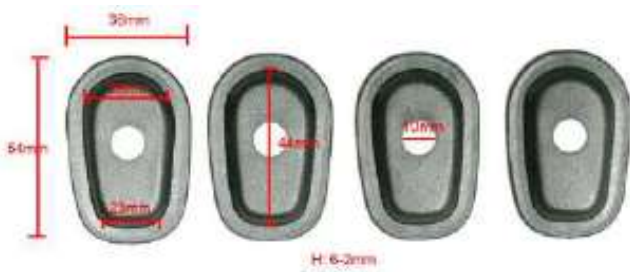

ADATTATORI MINIFRECCE

00-0110 Suzuki



ADATTATORI MINIFRECCE

00-0120 Suzuki



ADATTATORI MINIFRECCE

00-0130 Yamaha



ADATTATORI MINIFRECCE

00-0140 Yamaha



ADATTATORI MINIFRECCE

00-0160 Honda new model

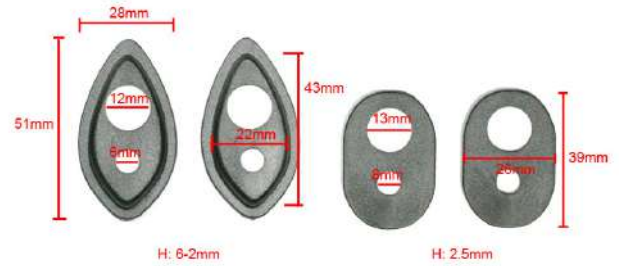

ADATTATORI MINIFRECCE

97235 Kawasaki



CNC

ADATTATORI MINIFRECCE

97238 Honda



CNC

ADATTATORI MINIFRECCE

97398 Suzuki



CNC

ADATTATORI MINIFRECCE

97399 Suzuki



CNC

ADATTATORI MINIFRECCE

97420 Yamaha, Kawasaki



CNC

COPPIA SOFFIETTI COPERTURA SNODO PEDANE MX

00-0531



TAPPO RADIATORE ACQUA 1.8 CON TERMOMETRO INTEGRATO

00-0620 Moto europee - KTM, Husqvarna, Aprilia...

00-0630 Moto Japan - Kawasaki, Yamaha, Honda, Suzuki



Realizzato in acciaio inossidabile # 430, lega di alluminio anodizzato e gomma siliconica
Termometro analogico con scala Celsius, da 0 a 200 °C, per visualizzare le temperature del liquido di raffreddamento

KIT PROTEZIONE TUBO SCARICO

00-0551 Nero



KIT 2 PEZZI PISTONCINI ALZA-SELLA

NEW

00-0771 Yamaha T-Max 500/530
2008-2018



PISTONCINO ALZA-SELLA

NEW

00-0781 Honda Silver Wing 400/600cc
2001-2017, X-ADV 750 2017

00-0791 Kymco Downtown
125/200/300/350, X-Town 125

00-0801 Honda Integra NC700 NC750



KIT 30 CUBETTI IN SPUGNA ANTI-SCUOTIMENTO PER SERBATOIO CARBURANTE

00-0685 Misura 5x5x5 cm, volume 3,8 litri



ANTIDFLAGRAZIONE - ANTISCUOTIMENTO - ANTISCIACQUO

Cubetti antiscuotimento in spugna reticolata per uso racing e offroad: stabilizzano il carburante nel serbatoio, evitano la formazione di vapore e i rischi connessi



Aggiornamenti sul sito www.forbikes.it

È vietato l'utilizzo su strada pubblica degli articoli non omologati.

FORBIKES
COMPONENTI PER MOTOCICLI

KIT CINGHIE ANCORAGGIO A STRAPPO

08-0067 Arancio



Lunghezza cinghia 160 cm

KIT CINGHIE ANCORAGGIO A STRAPPO

08-0071 Extra nero 40 mm



Lunghezza cinghia 160 cm

STRISCIA A MANUBRIO ANCORAGGIO CINGHIE

08-0080



CINGHIA SINGOLA ANCORAGGIO A CRICCHETTO

08-0540



KIT 10 PEZZI PERNO SGANCIO RAPIDO CON ANELLO E RONDELLE

08-0230



KIT 10 PEZZI RICETTACOLO PER ART.08-0230

08-0240 A rivetto

08-0250 A molletta



KIT 50 PEZZI RONDELLA TEFLON

08-0710 Viti M4

NEW

08-0260 Viti M5

08-0270 Viti M6



FERMACOPERTONE CON BATTUTA IN ALLUMINIO

08-0180 Anteriore, 1.40-1.60

08-0190 Posteriore, 1.85

08-0200 Posteriore, 2.15

08-0210 Posteriore, 2.50



KIT 10 PEZZI GOMMINI CON INSERTO FILETTATO

08-0630 Diametro 4x12,6

08-0220 Diametro 5 mm

08-0221 Diametro 6 mm



**KIT 6 PEZZI BULLONI CONICI
FISSAGGIO CORONA M8 X 34MM**

08-0330



**KIT 2 PEZZI MOLLA MARMITTA
UNCINO GIREVOLE**

08-0340 Dimensioni 57 mm

08-0350 Dimensioni 75 mm

08-0360 Dimensioni 83 mm

08-0370 Dimensioni 90 mm



**COPPIA SPINE FERMA-PASTIGLIE
PER PINZE L.50 MM**

08-0410



KIT 10 PEZZI RIVETTO A CLIP JAPAN STYLE PER CARENE

Tipo 1

08-0500



Tipo 2

08-0510



Tipo 3

08-0520



BLOCCALEVA FRENO ANTERIORE

08-0580



KIT RIPARAZIONE PNEUMATICI TUBELESS IN BORSETTA

08-0650 Chiave a T



PERSONALIZZABILE

**CARTUCCIA CO2 A RICAMBIO
16G**

NEW

08-0660



**KIT 5 PEZZI CARTUCCE CO2
A RICAMBIO**

NEW

08-0670



**KIT GONFIAGGIO RAPIDO
CON REGOLATORE**

NEW

08-0700 1 cartuccia CO2



KIT 68 PEZZI GIUNTI TUBI BENZINA (T, L, Y, I)

NEW

08-0680



**BIDONCINO CON POMPA
MULTIUSO**

NEW

08-0690 Capacità 1l



TERMOCOPERTE



COPPIA TERMOCOPERTE "RACE ITALY" 200/120 MM

08-0640 Triplo stadio con termostato 60° / 80° / 95°C



Le termocoperte RACE ITALY consentono agli pneumatici di raggiungere la temperatura ottimale in poco tempo garantendo, di conseguenza, un miglior rendimento della miscela nella sua tenuta.

Il **termostato digitale** permette la regolazione su tre livelli **60°C / 80°C / 95°C** e consente il loro utilizzo su pneumatici di tutte le marche sia a livello professionale che amatoriale, a differenza delle termocoperte impostate su un'unica temperatura fissa e non selezionabile.

Adatte per pneumatici con misura sul posteriore fino a 200/60, sono contraddistinte dal **tessuto tricolore** che richiama la bandiera italiana e sono dotate di un termometro digitale applicabile per il controllo della temperatura in aggiunta al led spia a raggiungimento della temperatura selezionata.

Aggiornamenti sul sito www.forbikes.it

È vietato l'utilizzo su strada pubblica degli articoli non omologati.

FORBIKES
COMPONENTI PER MOTOCICLI

**COPPIA VALVOLE RACING 97° ALLUM. 6061
DIAMETRO 10 MOTO JAPAN**

- 12-0260** Anodizzate colore argento
- 12-0261** Anodizzate colore nero
- 12-0263** Anodizzate colore blu
- 12-0264** Anodizzate colore rosso
- 12-0265** Anodizzate colore oro
- 12-0268** Anodizzate colore verde

**COPPIA VALVOLE RACING 97° ALLUM. 6061
DIAMETRO 8,3 MOTO EUROPEE**

- 12-0720** Anodizzate colore argento
- 12-0721** Anodizzate colore nero



SFIATO PER TAPPO OFF-ROAD

- 12-0630** Argento
- 12-0631** Nero
- 12-0633** Blu
- 12-0634** Rosso
- 12-0635** Oro
- 12-0637** Arancio
- 12-0638** Verde



**TUBO PVC CON VALVOLA SFIATO,
UNIDIREZIONALE**

- 12-0641** Nero
- 12-0643** Blu
- 12-0644** Rosso
- 12-0647** Arancio

**RULLINO CATENA DIAMETRO 32
H.23,5 MM**

14-0021

**KIT 4 PEZZI ELASTICI FISSAGGIO
MASCHERINA OFF-ROAD**

14-0131



MINI SERBATOIO LIQUIDO FRENI

14-0141 Uscita laterale

14-0151 Uscita centrale



CORNICE TARGA TIPO VECCHIO

00-0730 Cromata

00-0731 Nero



SUPPORTO TARGA TIPO VECCHIO

00-0740 Inox cromato

00-0741 Inox verniciato nero



PORTATARGA OFF ROAD CON FANALINO A LED "VYPER"

02-0310



CORNICE TARGA TIPO NUOVO

00-0750 Inox cromato

00-0751 Inox verniciato nero



SUPPORTO TARGA TIPO NUOVO

00-0760 Inox cromato

00-0761 Inox verniciato nero



OMOLOGATO

SUPPORTO TARGA ITALIA ALLUMINIO 6082 T6 ANODIZZATO NERO

12-0731



Adattatore per targhe italiane, leggero e resistente
Utile per l'installazione della targa su portatarga aftermarket

STAFFA SUPPORTO SERBATOIO FRENI NISSIN

	Rosso	Blu	Oro	Verde	Argento
Radial/Axial brake master cylinder	92662	92663	92668	92669	-
Radial clutch master cylinder	92678	92679	92680	92681	92684
Axial clutch master cylinder	92704	92705	92706	92707	92708

Radial/Axial brake master cylinder



Radial clutch master cylinder



Axial clutch master cylinder



TAPPO SERBATOIO OLIO FRENI DOPPIA ANODIZZAZIONE

	Rosso	Blu	Oro	Verde	Argento
NISSIN diametro 38 mm	92737	92738	92739	92740	92741
NISSIN diametro 42 mm	92732	92733	92734	92735	92736
NISSIN diametro 59 mm	92727	-	92729	92730	92731
BREMBO S30 / S35	92742	92743	92744	92751	92752

NISSIN Ø38



NISSIN Ø42



NISSIN Ø59



BREMBO S30 / S35



TAPPO CARICO OLIO MOTORE

	Rosso	Blu	Oro	Verde	Argento	Nero
M20 x P1,5	98393	98394	98395	98396	98397	98398
M20 x P2,5	98399	98400	98401	98402	98403	98404
M24 x P3	98405	98406	98407	98408	98409	98410
M27 x P1,5	98411	98412	98413	98414	98415	98416
M27 x P3	98417	98418	98419	98420	98421	98422

NEW



LEVA SMONTA GOMME

08-0020 L. 240 mm

08-0030 L. 400 mm

08-0040 Curvata L. 380 mm



KIT LEVE SMONTAGOMME CON CHIAVE ESAGONALE INTEGRATA

08-0560 Moto europee

08-0570 Moto Japan



Moto europee: 13, 27, 32 mm

Moto Japan: 12, 22, 32 mm

CHIAVE FILTRO OLIO

08-0090 65 mm
Honda / Yamaha / Kawasaki

08-0100 68 mm Suzuki

08-0120 76 mm Harley

08-0130 80 mm Honda old models

08-0320 BMW (new 1200) /
Piaggio con intagli



CHIAVE A "T" 8/10/12 MM

08-0150



KIT TAGLIO E RIBATTITURA CATENA TRASMISSIONE

08-0310



PERNO A RICAMBIO PER KIT TAGLIO RIBATTITURA ART.08-0310

08-0310A



TESSUTO ALLUMINIO TERMORIFRANGENTE ADESIVO

08-0380 250x200 mm

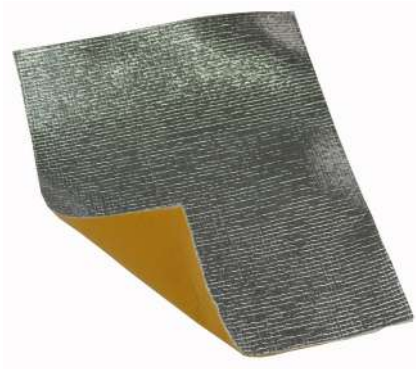

TESSUTO FONOASSORBENTE FILOMAT AS800

08-0390 1000x500x6 mm



PANNO FONOASSORBENTE PROFESS. ALTO SPESSORE CON SUPERFICIE IGNIFUGA 41SIK

08-0400 1000x500 mm



PINZA GIRAFILO (CONFEZIONATA)

08-0430



FILO INOX PER PINZA GIRAFILO

08-0440



KIT CRICCHETTO, CHIAVE CANDELA

08-0470 16, 18, 21 mm



SET 9 PEZZI CHIAVI A BRUGOLA MULTICOLOR

08-0490



1.5, 2, 2.5, 3, 4, 5, 6, 8, 10 mm

SET ATTREZZI RIMOZIONE CUSCINETTI

08-0530



MANOMETRO DI PRECISIONE PRESSIONE PNEUMATICI

08-0550



PULITORE PARAOLI FORCELLA E SEDI

08-0590



SPINE STOPPA FLUIDO OLIO E CARBURANTE (3 MISURE)

08-0600



CHIAVE ESAGONALE UNIV. PER PERNO RUOTA ANTERIORE (4 MISURE)

08-0610



NASTRO TELATO 48 MM X 25 M

08-0280 Argento

08-0281 Nero

08-0283 Blu

08-0284 Rosso

08-0285 Giallo

08-0288 Verde



NASTRO ADESIVO PER CABLAGGIO, PVC 25 M

NEW

94123 Largo 19 mm

94125 Largo 25 mm



DAYTONA



Aggiornamenti sul sito www.forbikes.it

È vietato l'utilizzo su strada pubblica degli articoli non omologati.

FORBIKES
COMPONENTI PER MOTOCICLI

PROTEZIONE SERBATOIO RESINATA

07-0301 Grafica Full Dakar



Fino ad esaurimento

PROTEZIONE SERBATOIO RESINATA

07-0311 Grafica GS



Fino ad esaurimento

PROTEZIONE SERBATOIO RESINATA

07-0321 Grafica Africa Twin



Fino ad esaurimento

PROTEZIONE SERBATOIO RESINATA

07-0341 Grafica Suzuki



Fino ad esaurimento

PROTEZIONE SERBATOIO RESINATA

07-0361 Grafica Aprilia



Fino ad esaurimento

PROTEZIONE SERBATOIO RESINATA

07-0371 Grafica MV



Fino ad esaurimento

PROTEZIONE SERBATOIO RESINATA

07-0381 Grafica KTM



Fino ad esaurimento

Le protezioni serbatoio resinare Forbikes hanno un design unico e distintivo per moto specifiche, perfette per proteggere il serbatoio da intemperie e graffi. Il colore nero è vivido e, insieme alla grafica studiata nei minimi dettagli, conferisce a qualsiasi moto un look aggressivo che non farà passare inosservati!



PROTEZIONE SERBATOIO RESINATA

TIPO 1

- 07-0011 Nero
- 07-0019 Similcarbonio



TIPO 2

- 07-0021 Nero
- 07-0029 Similcarbonio



TIPO 3

- 07-0031 Modulare nero
- 07-0039 Modulare similcarbonio

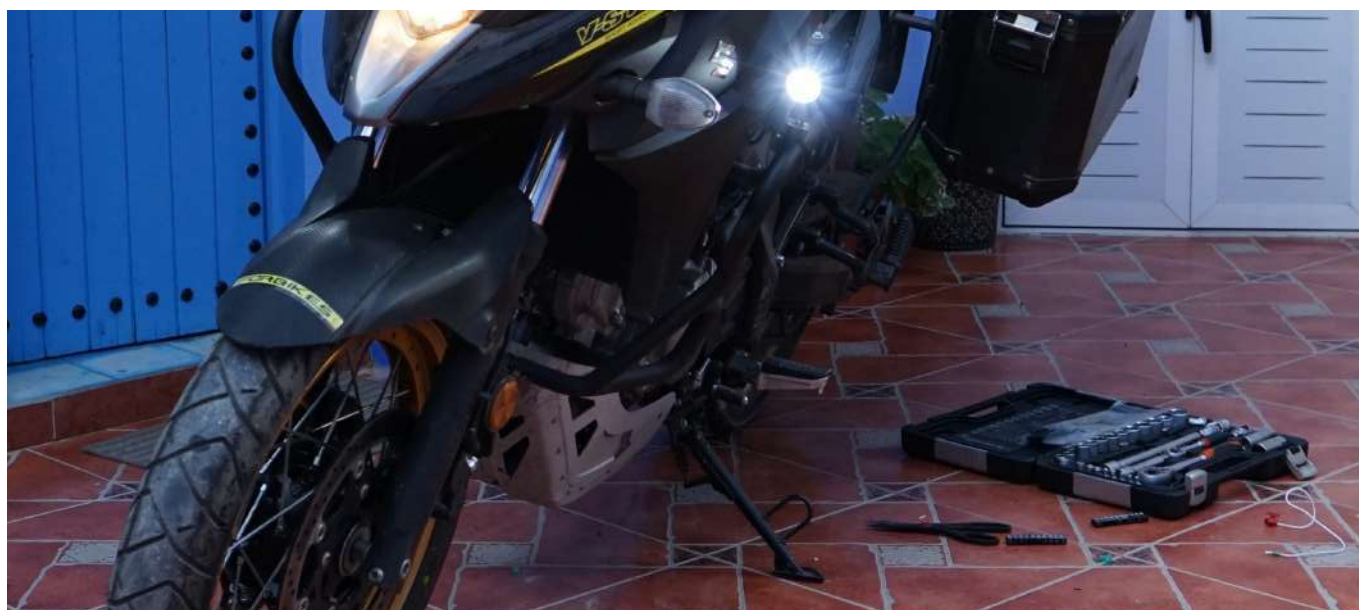

STRISCE PER CERCHI

- 07-0040 Effetto alluminio
- 07-0041 Nero
- 07-0042 Bianco rifrangente
- 07-0043 Blu rifrangente
- 07-0044 Rosso rifrangente
- 07-0045 Giallo fluo
- 07-0047 Arancio fluo
- 07-0048 Verde fluo

Strisce adesive di 7 mm x 6 m/lin per cerchi di 17". Costituite da un adesivo permanente, conformabile e adatto ad applicazioni in esterno.



APPLICATORE STRISCE PER CERCHI

- 07-0050



Aggiornamenti sul sito www.forbikes.it

È vietato l'utilizzo su strada pubblica degli articoli non omologati.



CENTRE TANK PAD



Con le protezioni centrali Eazi-Grip è possibile allestire la moto, sia sulle parti laterali che sulla parte centrale del serbatoio, con la stessa tipologia di materiale. Ai conosciuti ed apprezzati EVO, PRO, SIL si aggiunge anche SCTP, perfetto per chi non necessita grip ma vuole proteggere la vernice.

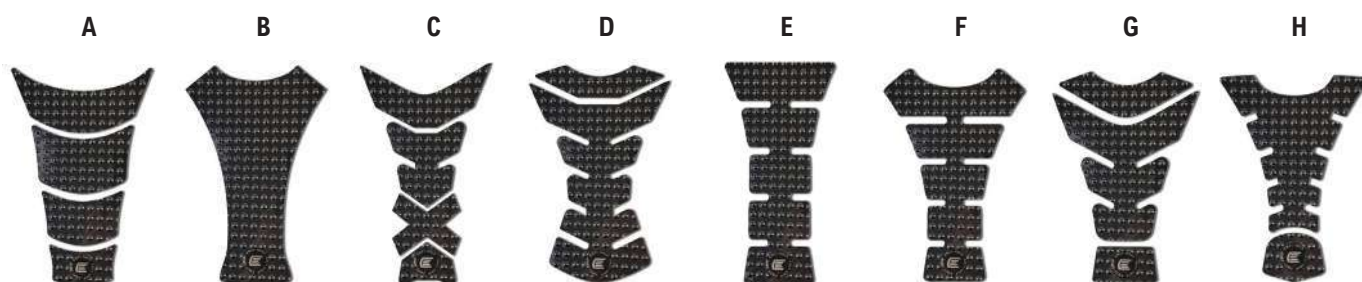

MODELLO	CODICE PRODOTTO
---------	-----------------

DESIGN A	
EVO TRASPARENTE	EVOCENTREPADA CL
EVO NERO	EVOCENTREPADA BL
PRO TRASPARENTE	PROCENTREPADA CL
PRO NERO	PROCENTREPADA BL
SILICONE	SILCENTREPADA BL
SCTP	SCTPCENTREPADA

DESIGN B	
EVO TRASPARENTE	EVOCENTREPAD BCL
EVO NERO	EVOCENTREPAD BBL
PRO TRASPARENTE	PROCENTREPAD BCL
PRO NERO	PROCENTREPAD BBL
SILICONE	SILCENTREPAD BBL
SCTP	SCTPCENTREPAD B

DESIGN C	
EVO TRASPARENTE	EVOCENTREPAD CCL
EVO NERO	EVOCENTREPAD CBL
PRO TRASPARENTE	PROCENTREPAD CCL
PRO NERO	PROCENTREPAD CBL
SILICONE	SILCENTREPAD CBL
SCTP	SCTPCENTREPAD C

MODELLO	CODICE PRODOTTO
---------	-----------------

DESIGN D	
EVO TRASPARENTE	EVOCENTREPAD DCL
EVO NERO	EVOCENTREPAD DBL
PRO TRASPARENTE	PROCENTREPAD DCL
PRO NERO	PROCENTREPAD DBL
SILICONE	SILCENTREPAD DBL
SCTP	SCTPCENTREPAD D

DESIGN E	
EVO TRASPARENTE	EVOCENTREPAD ECL
EVO NERO	EVOCENTREPAD EBL
PRO TRASPARENTE	PROCENTREPAD ECL
PRO NERO	PROCENTREPAD EBL
SILICONE	SILCENTREPAD EBL
SCTP	SCTPCENTREPAD E

DESIGN F	
EVO TRASPARENTE	EVOCENTREPAD FCL
EVO NERO	EVOCENTREPAD FBL
PRO TRASPARENTE	PROCENTREPAD FCL
PRO NERO	PROCENTREPAD FBL
SILICONE	SILCENTREPAD FBL
SCTP	SCTPCENTREPAD F

MODELLO	CODICE PRODOTTO
---------	-----------------

DESIGN G	
EVO TRASPARENTE	EVOCENTREPAD GCL
EVO NERO	EVOCENTREPAD GBL
PRO TRASPARENTE	PROCENTREPAD GCL
PRO NERO	PROCENTREPAD GBL
SILICONE	SILCENTREPAD GBL
SCTP	SCTPCENTREPAD G

DESIGN H	
EVO TRASPARENTE	EVOCENTREPAD HCL
EVO NERO	EVOCENTREPAD HBL
PRO TRASPARENTE	PROCENTREPAD HCL
PRO NERO	PROCENTREPAD HBL
SILICONE	SILCENTREPAD HBL
SCTP	SCTPCENTREPAD H

SCOPRI TUTTI I PRODOTTI EAZI-GRIP A PAGINA 119

CAVALLETTO ALZAMOTO POSTERIORE COMPONIBILE

06-0140 Con forchette

06-0150 Con tamponi



PERSONALIZZABILE

SMONTABILE

CAVALLETTO ALZAMOTO ANTERIORE SOTTOFORCELLA CON CURSORI

06-0160



PERSONALIZZABILE

SMONTABILE

CAVALLETTO POSTERIORE TRIUMPH BONNEVILLE

06-0283 Nero



Made in Italy

CAVALLETTO CON DOPPIA RUOTA SENZA CURSORI

06-0261 Posteriore

06-0271 Anteriore sottofork



Made in Italy

CAVALLETTO POSTERIORE DUCATI SCRAMBLER

06-0291



Made in Italy

CAVALLETTO POSTERIORE CON DOPPIA RUOTA SENZA CURSORI "EASY MOVER"

06-0541

Peso 8,2 kg
Lunghezza 73 cm
Larghezza 64 cm
Altezza 32,5 cm
Made in Italy



CAVALLETTO ANTERIORE BLOCCAGGIO AUTOMATICO

06-0241 Nero



RAMPA

Realizzata in alluminio e dotata di piedini di sostegno aggiuntivi, si caratterizza per essere leggera, robusta e pieghevole, permettendoti di caricare agevolmente moto e quad fino a 500 Kg.

Dimensioni: 2250x280x50 mm

RAMPA CARICO MOTO - QUAD IN ALLUMINIO

06-0250



CAVALLETTO MONOBRACCIO SINISTRO "ECO"

06-0200H	Con perno DUCATI diametro 21,5/25,5 mm
06-0200D	Con perno DUCATI 1098/MV diametro 40,5 mm
06-0200D1	Con perno DUCATI 1098/MV diametro 42,5 mm
06-0200I	Con perno HONDA diametro 28,5 mm
06-0200G	Con perno HONDA diametro 30,5 mm
06-0200B	Con perno BMW diametro 53,5 mm
06-0200A	Con perno TRIUMPH diametro 27,5 mm



CAVALLETTO MONOBRACCIO POSTERIORE SENZA PERNO

06-0301	Sinistro
06-0311	Destro



SMONTABILE

PERSONALIZZABILE

Made in Italy

PERNO CAVALLETTO MONOBRACCIO 06-0301 - 06-0311

06-0370 DUCATI (PANIGALE, 1098 STREETFIGHTER, 1198, MULTISTRADA 1200)
diametro 40,5 mm



06-0380 HONDA
diametro 28,7 mm



06-0390 DUCATI
diametro 29,8 mm



06-0400 BMW F650GS/F800-S/ST
diametro 30 mm



06-0410 BMW R1200GS
diametro 51 mm



06-0420 BMW
diametro 53 mm



06-0430 DUCATI
diametro 21,8 / 25,9 mm



06-0440 HONDA CB1000R
diametro 25,25 mm



06-0450 MV AGUSTA / DUCATI 1098/STREETFIGHTER/1198
diametro 42,50 mm



06-0460 TRIUMPH / KTM SUPERDUKE
diametro 27,5 mm



Aggiornamenti sul sito www.forbikes.it

È vietato l'utilizzo su strada pubblica degli articoli non omologati.

FORBIKES
COMPONENTI PER MOTORICOLI

**PEDANA ACCOSTA-MOTO
PORTATA 180 KG**

06-0231 Nero



Con freno

**PEDANA ACCOSTA-MOTO
PORTATA 400 KG**

06-0324 Rosso



Made in Italy

**PEDANA ACCOSTA-MOTO
PORTATA 500 KG**

06-0521 Nero



Con appendice per stampella laterale

**CAVALLETTO ALZAMOTO OFF-ROAD
A LEVA**

06-0187 Arancio



PERSONALIZZABILE

SMONTABILE

**CAVALLETTO OFF-ROAD IDRAULICO
A PANTOGRAFO PORTATA 140 KG**

06-0501 Nero



**CAVALLETTO IDRAULICO SOTTO
MOTORE MAXI CRUISER / CUSTOM**

06-0511 Nero



Portata 500 kg

**STAMPELLA LATERALE -
HUSQVARNA FE/FX/TE 2009-2016**

06-0483 400 mm, blu



**STAMPELLA LATERALE - KTM EXC/
EXC-F/XC/XC-F/XC-W 2008-2016**

06-0487 400 mm, arancio



**CAVALLETTO ANTERIORE
SOTTOCANNOTTO**

06-0531 8 perni inclusi





**COPPIA FORCHETTE PER
CAVALLETTO ALZAMOTO
POSTERIORE**

06-0090 Perno quadrato

06-0220 Perno arrotondato



Codice 06-0090 monta anche su 06-0261

**COPPIA TAMPONI IN GOMMA
PER CAVALLETTO ALZAMOTO
POSTERIORE**

06-0100 Perno quadrato

06-0490 Perno arrotondato



Codice 06-0100 monta anche su 06-0261

**COPPIA CURSORI SOTTOFORK PER
CAVALLETTO ANTERIORE 06-0271**

06-0340



**COPPIA CURSORI CONICI
SOTTOFORK PER CAVALLETTO
ANTERIORE 06-0271**

06-0350



**COPPIA CURSORI UNIVERSALI A
RULLI PER CAVALLETTO
ANTERIORE 06-0271**

06-0360



**COPPIA CURSORI RULLO PINZE
PER FRENI RADIALI PER
CAVALLETTO ANTERIORE 06-0271**

06-0470



Perno quadrato 20x20 mm

COPPIA NOTTOLINI CAVALLETTO, ANODIZZATI

VITE M6	
12-0690	Argento
12-0691	Nero
12-0693	Blu
12-0694	Rosso
12-0695	Giallo

VITE M8	
12-0700	Argento
12-0701	Nero
12-0703	Blu
12-0704	Rosso
12-0705	Giallo

VITE M10 X 1,5	
12-0710	Argento
12-0711	Nero
12-0713	Blu
12-0714	Rosso
12-0715	Giallo



CAVALLETTO POSTERIORE E-BIKE

NEW

06-0551 Nero

Peso 3,5 kg
Lunghezza 61 cm
Larghezza 35 cm
Altezza 35 cm



PERSONALIZZABILE

CAVALLETTO ANTERIORE BLOCCAGGIO AUTOMATICO E-BIKE

NEW

06-0561 Nero

Peso 10 kg
Apertura max 29"
Azionamento automatico



PERSONALIZZABILE

TUTA ANTIACQUA DIVISIBILE CON RIFRANGENTE

50-0111M Taglia M

50-0111L Taglia L

50-0111XL Taglia XL

Composta da giacca e pantaloni
Impermeabile 3000 mm
Colore nero con bande rifrangenti



TUTA ANTIACQUA DIVISIBILE VENTILATA, REGOLABILE

50-0121S Taglia S

50-0121M Taglia M

50-0121L Taglia L

50-0121XL Taglia XL

50-0121XXL Taglia XXL

Può essere riposta comodamente nel suo
astuccio, per ridurre notevolmente l'ingombro.
Impermeabile
Colore giallo fluo/nero



Aggiornamenti sul sito www.forbikes.it

È vietato l'utilizzo su strada pubblica degli articoli non omologati.

FORBIKES
COMPONENTI PER MOTORICLI

GIACCA SAFETY SENZA MANICHE CON RIFRANGENTE, REGOLABILE, VENTILATO

50-0135L Taglia M/L

50-0135XXL Taglia XL/XXL

Colore giallo fluo con bande rifrangenti
Comoda apertura a cerniera
Pratico taschino frontale
Leggera e confortevole



SCALDACOLLO IN COTONE

50-0061 Nero



SOTTOCASCO 100% COTONE

50-0151 Taglia unica



Tessuto leggero e traspirante
Adatto per periodo estivo

ESTIVO

SOTTOCASCO 100% MICROFIBRA

50-0161 Taglia unica



Protegge dal freddo e dal vento
Adatto per il periodo invernale

INVERNALE

COPPIA SAPONETTE "SLIDY"

51-0061 Nero

51-0063 Blu

51-0064 Rosso

51-0065 Giallo

51-0068 Verde



CINTURA LOMBARE STRADA

52-0071M Taglia S-M-L

52-0071XL Taglia L-XL-XXL



COPRIGAMBE IMPERMEABILE 5000 MM, REGOLABILE

50-0141 Nero, taglia unica



Coprigambe nero con rifrangenti e fodera interna

GUANTO ESTIVO PELLE/MESH MODELLO "ARIOSO" GRIGIO

53-0120S Taglia S

53-0120M Taglia M

53-0120L Taglia L

53-0120XL Taglia XL

53-0120XXL Taglia XXL



GUANTO ESTIVO PELLE/MESH MODELLO "ARIOSO" NERO

53-0121S Taglia S

53-0121M Taglia M

53-0121L Taglia L

53-0121XL Taglia XL

53-0121XXL Taglia XXL



GUANTO SPORTIVO PELLE MODELLO "GRINTOSO" NERO

53-0131S Taglia S

53-0131M Taglia M

53-0131L Taglia L

53-0131XL Taglia XL

53-0131XXL Taglia XXL



GUANTO ESTIVO PELLE MODELLO "STILOSO" NERO

53-0141S Taglia S

53-0141L Taglia L

53-0141XL Taglia XL

53-0141XXL Taglia XXL



Aggiornamenti sul sito www.forbikes.it

È vietato l'utilizzo su strada pubblica degli articoli non omologati.

FORBIKES
COMPONENTI PER MOTOCICLI

A-SIDER



A·SIDER
ASIDEROS PARA MOTOS DEPORTIVAS



CON IL PASSEGGERO ANCHE SULLE MOTO SPORTIVE

A-Sider rappresenta la soluzione ideale per gli amanti dei viaggi in due sulle moto sportive, **coniugando sicurezza e comodità**.

Grazie ad A-Sider il peso del passeggero non grava sul pilota in frenata e non scompone l'assetto in accelerazione, offrendo un punto di tenuta fisso. La pressione sul corpo del pilota si azzerava, la guida diventa più fluida e meglio bilanciata, il passeggero diventa parte integrante della moto, restando sempre in assetto ottimale.

Costituita in **alluminio inossidabile** e disponibile in colorazione nera o silver, A-Sider è facilissima da montare poiché sfrutta gli attacchi originali del **tappo del serbatoio** e garantisce una salda presa del passeggero che potrà finalmente viaggiare in tranquillità.

Il suo disegno è completamente integrato nella sagoma della moto e, insieme alla sua qualità e funzionalità, rende questo prodotto una soluzione ottima per le esigenze del mercato.



MODELLO	CODICE NERO	CODICE SILVER	NUMERO VITI
YAMAHA			
R1 1998-2014	YR011	YR010	5 VITI
R6 1999-2015	YR011	YR010	5 VITI
R6R FINO 2016	YR011	YR010	5 VITI
YZF-R3 2018	YR011	YR010	5 VITI
YZF-R3 2019-2022	YR021	YR020	3 VITI
R1 1998-2001	YR021	YR020	7 VITI

MODELLO	CODICE NERO	CODICE SILVER	NUMERO VITI
R6 1999-2003	YR021	YR020	7 VITI
R1-R1M 2015-2022	YR021	YR020	3 VITI
R6 2017-2020	YR021	YR020	3 VITI
FZ6 1998-2011	YF011	YF010	5 VITI
FZ8 2010-2016	YF011	YF010	5 VITI
FZ1 1998-2013	YF011	YF010	5 VITI
MT01 2010	YF011	YF010	5 VITI
MT03 2010	YF011	YF010	5 VITI
MT09 / SP FINO 2022	YF011	YF010	5 VITI
XJ6 N/S/F 2009-2016	YF011	YF010	5 VITI
NIKEN	YF011	YF010	5 VITI
FZR600,750,1000	YF021	YF020	7 VITI
DIVERSION 600-1000	YF021	YF020	7 VITI
THUNDERACE 1000	YF021	YF020	7 VITI
THUNDERCAT 600	YF021	YF020	7 VITI
MT010 2016-2022	YF021	YF020	3 VITI
MT03 2020-2022	YF021	YF020	3 VITI
R7 2022	YF021	YF020	3 VITI

HONDA

CBR600F 1991-2008	HRF011	HRF010	7 VITI
CBR600RR FINO 2012	HRF011	HRF010	7 VITI
CBR1100XX FINO 2011	HRF011	HRF010	7 VITI
CBR1000RR FINO 2014	HRF011	HRF010	7 VITI
CBR900 FINO 2003	HRF011	HRF010	7 VITI
VTR(S)(SP) FINO 2008	HRF011	HRF010	7 VITI
VFR 750-800 FINO 2013	HRF011	HRF010	7 VITI
NTV 650 FINO 2015	HRF011	HRF010	7 VITI
VFR 1200F FINO 2018	HRF011	HRF010	7 VITI
CBR650R 2019-2022	HRF021	HRF020	5 VITI
CBR500R (F) 2016-2022	HRF021	HRF020	5 VITI
CBR1000RR 2016-2021	HRF021	HRF020	5 VITI
VFR800F 2015-2018	HRF021	HRF020	5 VITI

SUZUKI

GSXR600/750 2004-2017	SR011	SR010	5 VITI
GSXR 1000 2004-2018	SR011	SR010	5 VITI
SV 650 2004-2018	SR011	SR010	5 VITI
SV 1000 2004-2012	SR011	SR010	5 VITI
GSXR 150 2018	SR011	SR010	5 VITI
KATANA 2019-2022	SF011	SF010	5 VITI
GSX-R 1000 2019-2022	SF011	SF010	5 VITI
INAZUMA	SF011	SF010	5 VITI
GSXR 1000 2003-2004	SF011	SF010	5 VITI
GSF, GSX 650 2005-2017	SF011	SF010	5 VITI
SV 650 2004-2020	SF011	SF010	5 VITI
SV 650X 2018-2022	SF011	SF010	5 VITI
GSR 600 2005-2013	SF011	SF010	5 VITI
GLADIUS 2009-2017	SF011	SF010	5 VITI
HAYABUSA (5 VITI)	SF011	SF010	5 VITI
GSR 750(Z) FINO 2017	SF011	SF010	5 VITI

MODELLO	CODICE NERO	CODICE SILVER	NUMERO VITI
GSX-S 750 2017-2022	SF011	SF010	5 VITI
GSX-S 1000 F 2016-2022	SF011	SF010	5 VITI
GSX, BANDIT, 1250 F 2017	SF011	SF010	5 VITI
GSX-S 150	SF011	SF010	5 VITI
GSX 250/300 R 2017-2020	SF011	SF010	5 VITI
GSX-S1000 GT 2022	SF011	SF010	5 VITI
GSXR 600/750/1000	SF021	SF020	7 VITI
SV 650/1000	SF021	SF020	7 VITI
BANDIT 650/750	SF021	SF020	7 VITI
HAYABUSA (7 VITI)	SF021	SF020	7 VITI
B-KING	SK011	SK010	3 VITI
KAWASAKI			
ZX636R 2003-2018	KR011	KR010	5 VITI
ZX6R 2000-2018	KR011	KR010	5 VITI
ZX10R 2003-2020	KR011	KR010	5 VITI
Z1000SX 2017-2020	KR011	KR010	5 VITI
Z1000 2003-2013	KR011	KR010	5 VITI
Z1000 2014-2020	KR041	KR040	5 VITI
Z750R 2013	KR011	KR010	5 VITI
Z750 2003-2013	KR011	KR010	5 VITI
Z800 2016	KR011	KR010	5 VITI
ZZR1400 2016-2019	KR011	KR010	5 VITI
ER6N-6F - 2006-2016	KR011	KR010	5 VITI
NINJA, Z, 250R, SL	KR021	KR020	6 VITI
NINJA 300 FINO 2016	KR021	KR020	6 VITI
1400 GTR	KR011	KR010	5 VITI
NINJA H2 SX 2019-2020	KR011	KR010	5 VITI
Z H2 2021	KR051	KR050	SENZA VITI
Z900 FINO 2022	KR051	KR050	SENZA VITI
Z650 2018-2022	KR051	KR050	SENZA VITI
Z400 2019-2022	KR051	KR050	SENZA VITI
NINJA 1000SX 2020-2022	KR051	KR050	SENZA VITI
NINJA 650 2017-2022	KR051	KR050	SENZA VITI
NINJA 400 2019-2022	KR051	KR050	SENZA VITI
ZX6R 2019-2022	KR051	KR050	SENZA VITI
ZX10R 2021-2022	KR051	-	SENZA VITI
NINJA SX 2022	KR051	-	SENZA VITI
DUCATI			
1000SS	DR011	DR010	5 VITI
1000DS	DR011	DR010	5 VITI
748	DR011	DR010	5 VITI
916	DR011	DR010	5 VITI
996	DR011	DR010	5 VITI
998	DR011	DR010	5 VITI
900 - ST3	DR011	DR010	5 VITI
1098 - 1198 2007-2012	DF011	DF010	5 VITI
848 - 2008-2013	DF011	DF010	5 VITI
MONSTER 600-1000	DF011	DF010	5 VITI
620 - 695 - S2R - S4R/S	DF011	DF010	5 VITI

MODELLO	CODICE NERO	CODICE SILVER	NUMERO VITI
MONSTER 821-1200	DF011	DF010	5 VITI
MONSTER 797	DF011	DF010	5 VITI
MONSTER 937 2021	DF011	DF010	5 VITI
SUPER SPORT 2017-2021	DF011	DF010	5 VITI
PANIGALE 1199-1299	DAF011	DAF010	SENZA VITI
PANIGALE 959	DAF011	DAF010	SENZA VITI
PANIGALE V4 - V2	DAF011	DAF010	SENZA VITI
STREETFIGHTER V4 - V2	DAF011	DAF010	SENZA VITI
MV AGUSTA			
F4 750-1000 FINO 2009	DR011	DR010	5 VITI
BRUTALE FINO 2009*	DR011	DR010	5 VITI
F4 1000 2016-2018	DAF011	DAF010	SENZA VITI
BRUTALE 1090-1000 RR - 800RR	DAF011	DAF010	SENZA VITI
BRUTALE 675 / 800 (2020)	TR011	TR010	6 VITI
RIVALE 800	TR011	TR010	6 VITI
DRAGSTER 800 FINO 2020	TR011	TR010	6 VITI
F3 800 2016-2021	TR011	TR010	6 VITI
F3 675	TR011	TR010	6 VITI
SUPERVELOCE	TR011	TR010	6 VITI
CAGIVA			
MITO 125	DR011	DR010	5 VITI
TRIUMPH			
DAYTONA 675 2006-2018, 765 2019-2022	TR011	TR010	6 VITI
STREET TRIPLE 2008-2022	TR011	TR010	6 VITI
SPEED TRIPLE 1050 RS 2008-2021	TR011	TR010	6 VITI
SPRINT ST- GT 2008-2015	TR011	TR010	6 VITI
SPEED FOUR 600 2000-2006	TR011	TR010	6 VITI
DAYTONA 955i 1998-2006	TR011	TR010	6 VITI
SPEED TRIPLE 1200 RS 2021-2022	BR011	BR010	6 VITI
BMW			
S1000RR	BR021	BR020	SENZA VITI
S1000R	BR021	BR020	SENZA VITI
R850R, R1100R, FINO 2006	BR011	BR010	6 VITI
R1150R, R1200R, FINO 2006	BR011	BR010	6 VITI
R1250R / R1250RS	BR011	BR010	6 VITI
R1200RS 2016-2019	BR011	BR010	6 VITI
KTM			
*RC8R	DAR011	DAR010	SENZA VITI
SUPERDUKE 1290 / R	BR011	BR010	6 VITI
RC 390	KR031	KR030	7 VITI
APRILIA			
RSV4	DAR011	DAR010	SENZA VITI
TUONO RSV4 FINO 2020	DAF011	DAF010	SENZA VITI
RSV4 RR/RF 1100 2020	DAF011	DAF010	SENZA VITI
SHIVER 750-900	TR011	TR010	6 VITI
RS 660 2021-2022	TR011	TR010	6 VITI

BARKBUSSTERS



 **Barkbusters**
HANDGUARDS



I PARAMANI NATI PER L'AVVENTURA PIÙ ESTREMA

L'australiana Barkbusters produce **paramani** in grado di unire stile, resistenza e durata nel tempo.

Con un team di appassionati motociclisti, Barkbusters è diventato velocemente leader nella produzione di paramani di altissima qualità a livello internazionale aggiungendo a catalogo anche accessori, kit di montaggio specifici, indicatori di posizione per paramani, protezioni leva e molto altro.

Le protezioni Barkbusters si riconoscono per forme diverse, **modelli variegati** e una conformazione delle plastiche ben studiata e calibrata per il settore a cui sono destinate. Essenziali per una protezione da eventuali urti ma anche contro le condizioni meteo avverse che possono indebolire la sensibilità sui comandi.

Chi li ha provati, non è più voluto tornare indietro!



JET

Snelle, agili e coloratissime per adattarsi a tutti i modelli di moto più famosi. Sono estremamente resistenti e progettate per moto Dual-Sport, Enduro e Trail.



EGO

Stile inconfondibile con un profilo incurvato e ampissimo range di colori, rappresentano protezioni ad alta resistenza agli urti e sono progettati per Enduro, Trail e Mini Bikes.



VPS

Con linee più grandi ma sempre in tantissimi colori, sono pensati per Enduro, Supermoto, ATV, Street e Adventure. Dotati di deflettori che possono essere montati in due posizioni.



STORM

Per chi cerca massima protezione senza rinunciare allo stile. Ottima protezione da vento, freddo e urti accidentali con detriti stradali. Disponibili in nero o in bianco.



CARBON

Realizzati in vera fibra di carbonio, sono una miscela unica di stile e praticità. Rifiniti con trattamento in resina, proteggono le mani contro il freddo e le intemperie.



BBZ

A prova di nubifragio, sono perfetti per proteggere le mani da freddo e intemperie. Progettati per Street, Cruiser, Naked, Touring, ATV, Adventure e Scooters.



SABRE

Specificamente progettate per Motocross e Enduro. Sagoma sottile e design minimale. Sfiati per una maggiore ventilazione e deflettori per una protezione estrema.



PROTEZIONI LEVA AERO-GP

AGP-001-01-BK

Robuste, aerodinamiche e progettate sia per moto stradali che da pista. Concepite pensando alla sicurezza e, allo stesso tempo, create per completare l'estetica delle moto.



KIT MONTAGGIO PARAMANI

Realizzati in alluminio trattato termicamente per una maggiore resistenza e protezione dagli urti. Doppio punto di attacco e specifici per ogni modello di moto.



CLICK N' RIDE



CLICK'N'RIDE[®]
QUICK RELEASE MOTORCYCLE TURN INDICATORS



I PRIMI INDICATORI DI DIREZIONE RIMOVIBILI

“Mai più frecce distrutte!” è il motto del brand australiano ideatore degli indicatori di direzione rimovibili. Infatti al cuore del design di Click N' Ride vi è l'innovativo **sistema di sgancio rapido** che permette l'attacco e lo sgancio con un semplice click e consente di non doversi più preoccupare di cercare ricambi ed effettuare riparazioni ma permette di godersi l'uscita in spensieratezza.

Una volta rimossi, il nuovo sistema Moisture Guard permette di proteggere la parte di attacco da polvere, fango ed acqua nell'utilizzo off-road. Mentre le frecce possono essere comodamente riposte nella confezione Roll Up, pronte per essere rimontate all'occorrenza.

Gli indicatori Click N' Ride sono dotati di un **attacco universale**, non hanno parti mobili o che possano deteriorarsi e sono realizzati con materiali di alta qualità per una durata estrema. Grazie ai LED Philips viene garantita un'alta luminosità, un colore dell'ambra stabile e una durata fino a 50.000 ore.

Sono stati sottoposti a rigidi test per assicurarne l'omologazione su strada. I test sono stati condotti secondo lo **standard UNECE R50** che non include solo specifiche legate all'utilizzo motociclistico come l'intensità della lampada, il colore, la distanza e l'angolazione del fascio ma garantisce anche che la produzione rispetti gli standard di qualità ISO9001.



CLICKNRIDE®

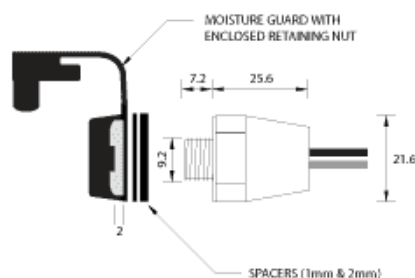
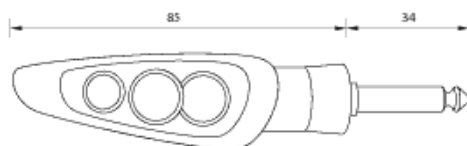



**KIT 2 PEZZI FRECCHE ATTACCO/
SGANCIO RAPIDO CLICK N'RIDE**

CNR-4202



**KIT 4 PEZZI FRECCHE ATTACCO/
SGANCIO RAPIDO CLICK N'RIDE**

CNR-4204



FRECCIA A RICAMBIO

CNR-4205-L Sinistra posteriore /
destra anteriore

CNR-4205-R Destra posteriore /
sinistra anteriore



PRESA UNIVERSALE A RICAMBIO

CNR-4206



COPPIA RESISTENZE A LED

CNR-4207



**CONFEZIONE ROLL UP PER
TRASPORTO**

CNR-4208



DAYTONA



DAYTONA



DESIGN MINIMALE E PRECISIONE GIAPPONESE

Daytona ha sede in Giappone e dal 1972 è leader nel settore dei ricambi ed accessori, originali e personalizzati, per il mercato motociclistico internazionale.

Tutti i suoi prodotti sono realizzati con la **massima cura ai dettagli**, garantita dalle fasi di progettazione e di produzione svolte sotto l'attento controllo giapponese. Infatti tutti i prodotti a catalogo hanno trovato un ottimo riscontro tra i motociclisti italiani e non.

Il team di ricerca e sviluppo di Daytona è continuamente alla ricerca di novità per soddisfare al meglio le necessità dei motociclisti. L'**ampia gamma** di articoli a catalogo comprende diverse categorie di prodotti, tra cui fanaleria, manopole, strumentazioni di alto livello e finiture, articoli con doppia anodizzazione e colorazioni mozzafiato.

Già da alcuni anni Forbikes collabora con Daytona per portare in Italia gli accessori del brand giapponese e soddisfare la **crescente richiesta** del mercato italiano. Ogni anno i prodotti del brand giapponese si ri-confermano di ottima qualità e, grazie allo stile inconfondibile e un design pulito e minimal, soddisfano anche i motociclisti più esigenti.

SCARICA IL CATALOGO COMPLETO NELL'AREA DOWNLOAD SU WWW.FORBIKES.IT



DIAMETRO 48 MM

TACHIMETRO ANALOGICO ELETTRONICO VELONA NERO

87383 Diametro 48 mm, 140 KM/H

87386 Diametro 48 mm, 200 KM/H

87389 Diametro 48 mm, 260 KM/H

Comprende la staffa

Display LED intercambiabile in 3 colori (blu, bianco, arancio)



E-MARKED



87383



87386



87389



CONTAGIRI ANALOGICO ELETTRONICO VELONA NERO

87392 Diametro 48 mm, 9000 RPM

87395 Diametro 48 mm, 15000 RPM

87392



87395

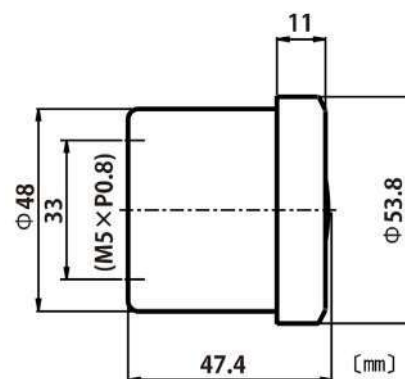

Comprende la staffa

Display LED intercambiabile in 3 colori (blu, bianco, arancio)

STAFFA PER SUPPORTO STRUMENTO VELONA DIAM. 48 MM PER SPIE MICRO LED

87768 Singolo

87785 Doppio



DIAMETRO 60 MM

TACHIMETRO ANALOGICO ELETTRONICO VELONA

- 85833** Diametro 60 mm, 200 KM/H
- 86863** Diametro 60 mm, 200 KM/H, nero
- 86267** Diametro 60 mm, 260 KM/H
- 86861** Diametro 60 mm, 260 KM/H, nero

Comprende staffa a V
Profondità 42,5 mm



E-MARKED

TACHIMETRO ANALOGICO ELETTRONICO VELONA CON SPIE

- 88641** Diametro 60 mm, 140 KM/H
- 88642** Diametro 60 mm, 200 KM/H
- 88643** Diametro 60 mm, 260 KM/H



E-MARKED

Comprende la staffa

CONTAGIRI ANALOGICO ELETTRONICO VELONA

- 85835** Diametro 60 mm, 8000 RPM
- 86864** Diametro 60 mm, 8000 RPM, nero
- 87527** Diametro 60 mm, 15000 RPM, nero
- 85834** Diametro 60 mm, 18000 RPM
- 86862** Diametro 60 mm, 18000 RPM, nero

Comprende staffa a V
Display a LED



CONTAGIRI ANALOGICO ELETTRONICO VELONA CON INDICATORE DI CAMBIO MARCIA

88644 Diametro 60 mm, 9000 RPM

88645 Diametro 60 mm, 15000 RPM

88677 Diametro 60 mm, 15000 RPM

88644



Comprende la staffa

88645



88677



STRUMENTO ROUND DIGITAL VELONA

85836 Diametro 60 mm, nero



E-MARKED

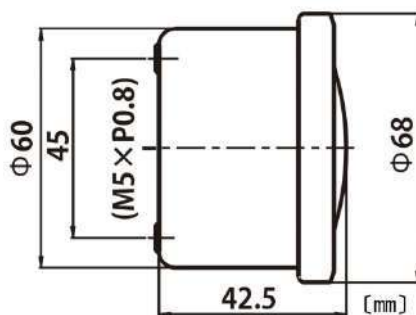

Comprende staffa a V
Display LCD nero con retroilluminazione a LED
In acciaio inossidabile

KIT CORNICE ALLUMINIO CNC

85819 Cromato



Per strumenti serie VELONA diametro 60 mm

STAFFA PER SUPPORTO STRUMENTO VELONA DIAM. 60 MM E SPIE MICRO LED

87403 Lucido

87404 Nero

87403



87404



SUPPORTO ANTI-VIBRAZIONE PER VELONA 60

- 61197** Centrale / piegato 10°
- 63526** Centrale
- 63527** Sinistro OFFSET / piegato 10°
- 63528** Destro OFFSET / piegato 10°
- 63529** Destro OFFSET



DIAMETRO 80 MM

TACHIMETRO ANALOGICO ELETTRONICO VELONA

- 87789** Diametro 80 mm, 140 KM/H + RPM in LCD
- 87790** Diametro 80 mm, 200 KM/H + RPM in LCD
- 87791** Diametro 80 mm, 260 KM/H + RPM in LCD

Comprende staffa a V
In acciaio inossidabile

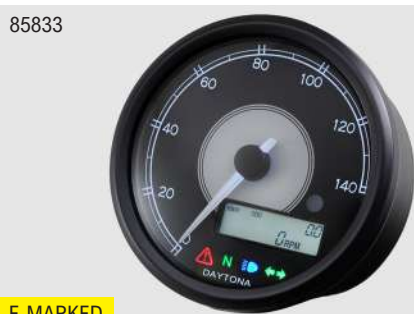

E-MARKED

TACHIMETRO ANALOGICO ELETTRONICO VELONA CON INDICATORE VELOCITÀ ELETTRICO

- 89364** Diametro 80 mm, 200 KM/H

Comprende staffa a V
In acciaio inossidabile



E-MARKED

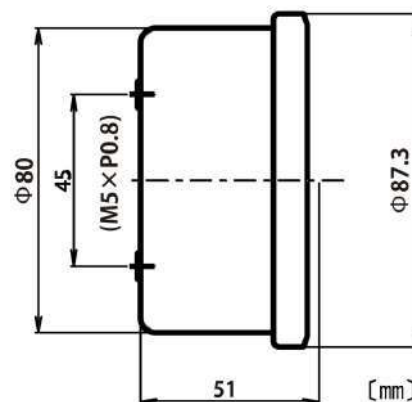

CONTAGIRI ANALOGICO ELETTRONICO VELONA

87792 Diametro 80 mm, 9000 RPM + SPD in LCD

87793 Diametro 80 mm, 15000 RPM + SPD in LCD

87792

87793



E-MARKED

Comprende staffa a V
In acciaio inossidabile

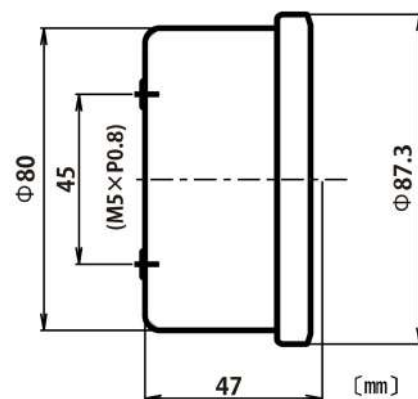

TACHIMETRO DIGITALE COMPATTO "NANO"

85998 300 KM/H



40x60x17,6 mm
Senza retroilluminazione
Include sensore di velocità

TACHIMETRO DIGITALE COMPATTO "NANO2"

86596 399 KM/H



40x60x22 mm
Retroilluminazione a LED bianca
Include sensore di velocità

CONTAGIRI DIGITALE COMPATTO "NANO2"

86719 20000 RPM



40x60x22 mm
Retroilluminazione a LED bianca

TERMOMETRO DIGITALE OIL/AIR COMPATTO "NANO"

85995



40x60x17,6 mm
Senza retroilluminazione
Include sensore R1/8

CONTAMARCE DIGITALE "NANO2"

86533



40x60x22 mm
Retroilluminazione a LED bianca

STRUMENTAZIONE MULTIFUNZIONE MODELLO "ASURA"

84580 Silver

84787 Nero

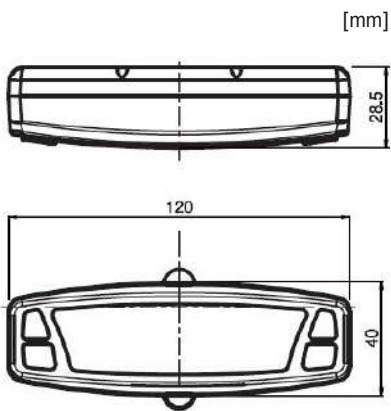

E-MARKED

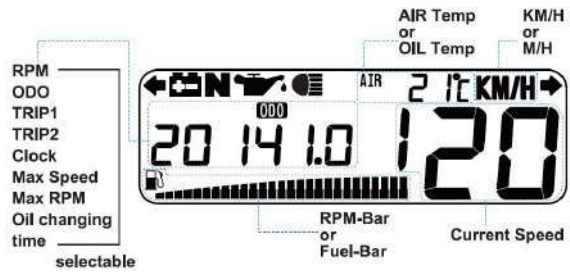

STRUMENTAZIONE MULTIFUNZIONE DIGITALE "DEVA"

89363

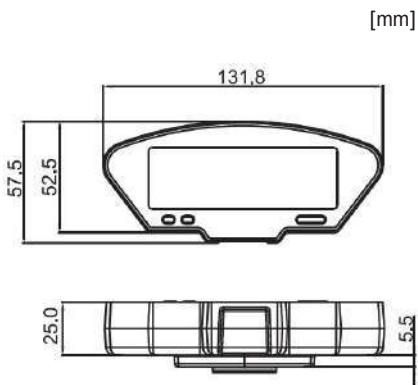

E-MARKED

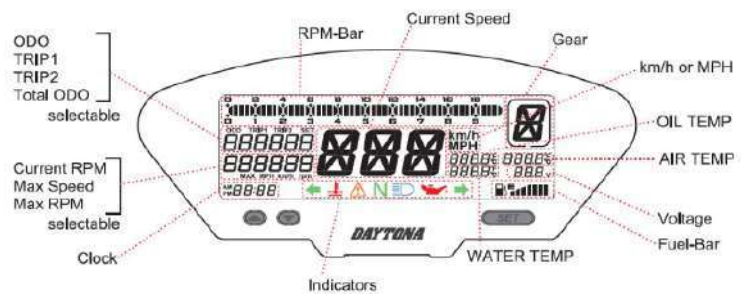

NEW

KIT CONNETTORI TYPE 110

96167	2 pin
96168	3 pin
96169	4 pin
96170	6 pin
96171	9 pin

Compresi terminali e connettori maschio e femmina



KIT CONNETTORI TYPE 250

NEW

96172	2 pin
96173	3 pin
96174	4 pin
96175	6 pin

Compresi terminali e connettori maschio e femmina



KIT CONNETTORI HM

NEW

96182	2 pin
96183	3 pin
96184	4 pin
96185	6 pin

Compresi terminali e connettori maschio e femmina

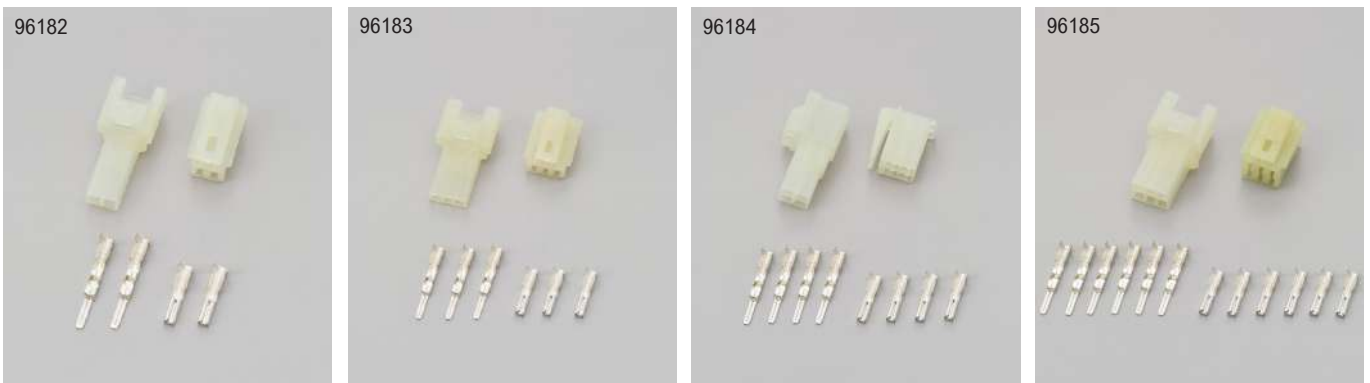

KIT CONNETTORI HM WATERPROOF

96176 2 pin

96177 3 pin

96178 4 pin

96179 6 pin

Compresi terminali, guarnizioni e connettori maschio e femmina

96176



96177



96178



96179



KIT CONNETTORI MT WATERPROOF

96180 3 pin

96181 4 pin

96180



96181



TERMINALI PER HM/MT CONNETTORE WATERPROOF

96303 Set di 30



TERMINALI CAPICORDA TONDI

96155 CA/CB103, set di 5

96153 CA/CB103, set di 30

96157 CA/CB104, set di 5

96156 CA/CB104, set di 30

96158 Per Kawasaki, set di 30

96155



96153



96157



96156



96158



TERMINALI CAPICORDA PIATTI

NEW

- 96160 110-TYPE, set di 5
- 96159 110-TYPE, set di 30
- 96162 250-TYPE, set di 5
- 96161 250-TYPE, set di 30

96160 96162
96159 96161



CAPICORDA IMPERMEABILI

NEW

- 61938 CA/CB103, set di 5
- 41220 CA/CB103, set di 20
- 61939 CA/CB104, set di 5
- 41221 CA/CB104, set di 20

61938 61939
41220 41221



TERMINALE CAPICORDA DOPPIO

NEW

- 96304 CA/CW104, set di 5
- 96305 CA/CW103, set di 5

96304



96305



TERMINALI CAPICORDA PIATTI 187-TYPE

NEW

- 96163 Set di 5



CONNETTORI PER MOTO H4

NEW

- 96186



CONNETTORE, LOCKING TYPE, 250-TYPE

NEW

- 96187 2 pin
- 96188 3 pin
- 96189 4 pin
- 96190 6 pin

Compresi terminali e connettori maschio e femmina

96187



96188



96189



96190



NEW**KIT CONNETTORI FRECCIE**

15414	Kawasaki 2 pin, 040-TYPE
96199	Kawasaki 2 pin, nero
96200	Kawasaki 2 pin, grigio
96191	Honda 2 pin, azzurro
96192	Honda 2 pin, arancione
96300	Honda 2 pin, 050-TYPE, azzurro
96301	Honda 2 pin, 050-TYPE, arancione
96302	Honda 3 pin, 050-TYPE, bianco
96193	Suzuki 2 pin, nero
96194	Suzuki 2 pin, grigio
96195	Suzuki 2 pin, bianco

**5 PEZZI CAPICORDA AD ANELLO****NEW**

96164	LA106, diametro interno 6 mm
96165	LA108, diametro interno 8 mm
96166	LA110, diametro interno 10 mm

**5 PEZZI CAPICORDA A C PER UTENSILI MANUALI****NEW**

69062	Diametro 6 mm
69063	Diametro 8 mm

**CAPPUCCIO DI PROTEZIONE CONNETTORE****NEW**

96206	Diametro 8x22x70 mm
96207	Diametro 16x37x84 mm
96208	Diametro 27x42x84 mm



**CABLAGGIO AWG16
(AVS1.25SQ), 1M****NEW**

- 93203 Nero
- 93201 Rosso
- 93202 Verde

**CABLAGGIO AWG14
(AVS2.0SQ), 1M****NEW**

- 93206 Nero
- 93204 Rosso
- 93205 Verde

**CABLAGGIO AWG20
(AVS0.5SQ), 2M****NEW**

- 65098 Nero
- 65097 Rosso
- 65099 Verde

**CABLAGGIO AWG18 (AVS0.75SQ), 2M****NEW**

- 93182 Nero
- 93181 Rosso
- 93183 Verde
- 93184 Azzurro
- 93185 Arancione
- 93186 Blu
- 93187 Bianco
- 93188 Giallo
- 93189 Verde/giallo
- 93190 Marrone
- 93191 Verde chiaro
- 93192 Nero/bianco
- 93193 Bianco/nero
- 93194 Grigio
- 93195 Nero/giallo
- 93196 Rosso/nero
- 93197 Rosso/giallo
- 93198 Nero/marrone
- 93199 Arancione/bianco
- 93200 Azzurro/bianco



GUAINA PVC CABLAGGIO, 2M

NEW

- 96212 Diametro interno 5 mm
- 96213 Diametro interno 8 mm
- 96214 Diametro interno 10 mm
- 96215 Diametro interno 13 mm



GUAINA TRECCIATA PET, 5M

NEW

- 16043 Diametro interno 6 mm
- 16044 Diametro interno 8 mm
- 16053 Diametro interno 10 mm
- 16057 Diametro interno 12 mm



GUAINA TERMORESTRINGENTE

NEW

- 16064 Diametro 3,2 mm, 3M nero
- 16068 Diametro 3,2 mm, 3M rosso
- 16065 Diametro 6,4 mm, 3M nero
- 16069 Diametro 6,4 mm, 3M rosso
- 16066 Diametro 9,5 mm, 1,2M nero
- 16070 Diametro 9,5 mm, 1,2M rosso
- 16067 Diametro 15 mm, 1,2M nero
- 16071 Diametro 15 mm, 1,2M rosso



16064



16065



16066



16067



GUAINA TERMORESTRINGENTE

NEW

- 96201 Diametro 3x70 mm, set di 10
- 96202 Diametro 6x70 mm, set di 10
- 96203 Diametro 8x70 mm, set di 10
- 44068 Diametro 19x120 mm, set di 2
- 44069 Diametro 25x120 mm, set di 2
- 44070 Diametro 38x120 mm, set di 2



TUBO PASSACAVO, CON FESSURA, 2M

NEW

- 96204 Diametro interno 7 mm
- 96205 Diametro interno 10 mm

96204



96205



**TUBO CARBURANTE IN PVC 1M ROSA,
CON 5 CLIPS**

NEW

91857	3x6 mm
91858	4x7 mm
91859	5x8 mm
91860	6x9 mm



**TUBO CARBURANTE A 2 STRATI 1M,
CON 5 CLIPS**

NEW

96460	Diametro interno 4 mm / diametro esterno 8 mm
96461	Diametro interno 5 mm / diametro esterno 10mm
96462	Diametro interno 6 mm / diametro esterno 10 mm
96463	Diametro interno 8 mm / diametro esterno 13 mm
96464	Diametro interno 10 mm / diametro esterno 15 mm



KIT 2 PEZZI FASCETTE STRINGITUBO A MOLLA LARGHE

NEW

91238	6 mm
91239	7 mm
91240	8 mm
91241	9 mm
91242	10 mm
91243	11 mm
91244	12 mm
91245	13 mm
91246	14 mm



KIT 10 PEZZI FASCETTE STRINGITUBO A MOLLA

NEW

91420	6 mm
91422	8 mm
91423	9 mm
91424	11 mm
91425	13 mm
91426	15 mm



SCHIACCIATUBO

NEW

91110



EAZI-G RIP



E EAZI-GRIP™
RACING PRODUCTS

LA SCELTA DI TANTISSIMI TEAM RACING

Fondato nel 2011, il brand Eazi-Grip™ continua a crescere ed affermarsi in tutto il mondo al fianco dei migliori team realizzando prodotti altamente ricercati:

Adesivi paraserbatoio, il prodotto di punta del brand inglese. Pre-tagliati e specifici per tantissimi modelli di moto, sono disponibili in nero o trasparente e nelle texture: EVO (bolle grandi e distanziate), PRO (bolle piccole e ravvicinate), SIL (silicone nero con nessuna bolla), SCTP (trasparente e perfetto per proteggere la vernice).

Protezione serbatoio integrale progettata con lo stesso materiale della serie SIL. Fornisce un'alternativa full coverage mantenendo, al tempo stesso, un alto livello di grip e proteggendo la verniciatura.

Protezione centrale, 8 diversi modelli disponibili nelle stesse texture dei paraserbaio: EVO, PRO SIL e SCTP.

Pellicola protettiva non ingiallente ed ultrasottile, estremamente resistente e progettata per proteggere la moto e limitare possibili danni.

Kit di tubi in silicone progettati per resistere a temperature estreme e pressioni osservate su moto ad alte prestazioni.

Protezione strumentazione antigraffio e di facile installazione, offre un'eccellente copertura dello schermo.

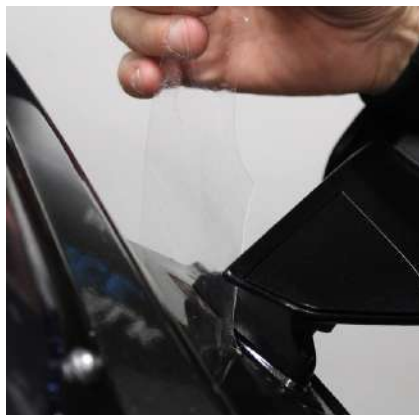

ADESIVI ANTISCIVOLO PARASERBATOIO



EVO SERIES

bolle grandi e distanziate,
massimo grip



PRO SERIES

bolle piccole e ravvicinate,
profilo elegante e dinamico



SILICONE SERIES

nessuna bolla, superficie
ruvida



STONE CHIP TANK PROTECTION

pellicola protettiva

MODELLO	ANNI	EVO SERIES		PRO SERIES		SILICONE SERIES	STONE CHIP TANK PROTECTION
		CODICE TRASPARENTE	CODICE NERO	CODICE TRASPARENTE	CODICE NERO	CODICE NERO	CODICE
APRILIA							
RSV1000	2004-2010	EVO001CL	EVO001BL	PRO001CL	PRO001BL	SIL001BL	SCTP001
RSV4	2008-2020	EVO002CL	EVO002BL	PRO002CL	PRO002BL	SIL002BL	SCTP002
TUONO	2006-2010	EVO003CL	EVO003BL	PRO003CL	PRO003BL	SIL003BL	SCTP003
TUONO V4	2011-2020	EVO004CL	EVO004BL	PRO004CL	PRO004BL	SIL004BL	SCTP004
RS4 125 / TUONO 125 / RS 125	2011-	EVO005CL	EVO005BL	PRO005CL	PRO005BL	SIL005BL	SCTP005
CAPONORD 1200 1200 RALLY	2013-	EVO007CL	EVO007BL	PRO007CL	PRO007BL	SIL007BL	SCTP007
SHIVER 750/900	2008-	EVO008CL	EVO008BL	PRO008CL	PRO008BL	SIL008BL	SCTP008
RS660 / Tuono 660	2021-	EVO009CL	EVO009BL	PRO009CL	PRO009BL	SIL009BL	SCTP009
RSV4 / TUONO V4	2021-	EVO010CL	EVO010BL	PRO010CL	PRO010BL	SIL010BL	SCTP010
BMW							
K1200S/K1300S	2005-2016	EVO100CL	EVO100BL	PRO100CL	PRO100BL	SIL100BL	SCTP100
K1200R/K1300R	2005-2015	EVO102CL	EVO102BL	PRO102CL	PRO102BL	SIL102BL	SCTP102
S1000R/RR	2009-2013	EVO104CL	EVO104BL	PRO104CL	PRO104BL	SIL104BL	SCTP104
S1000R/RR	2014	EVO105CL	EVO105BL	PRO105CL	PRO105BL	SIL105BL	SCTP105
F800ST	2006-2013	EVO106CL	EVO106BL	PRO106CL	PRO106BL	SIL106BL	SCTP106
R1200GS R1300GS	2004-2012	EVO107CL	EVO107BL	PRO107CL	PRO107BL	SIL107BL	SCTP107
S1000RR	2015-2018	EVO108CL	EVO108BL	PRO108CL	PRO108BL	SIL108BL	SCTP108
R1200RS	2015-2018	EVO109CL	EVO109BL	PRO109CL	PRO109BL	SIL109BL	SCTP109
S1000XR	2015-2019	EVO110CL	EVO110BL	PRO110CL	PRO110BL	SIL110BL	SCTP110
F800GS	2015-2017	EVO111CL	EVO111BL	PRO111CL	PRO111BL	SIL111BL	SCTP111
1600GTLE	2011-2016	EVO112CL	EVO112BL	PRO112CL	PRO112BL	SIL112BL	SCTP112
R9T	2014-	EVO113CL	EVO113BL	PRO113CL	PRO113BL	SIL113BL	SCTP113
R1200RT	2014-2018	EVO114CL	EVO114BL	PRO114CL	PRO114BL	SIL114BL	SCTP114
F800R	2009-	EVO115CL	EVO115BL	PRO115CL	PRO115BL	SIL115BL	SCTP115
R1200GS RALLYE	2017-2018	EVO116CL	EVO116BL	PRO116CL	PRO116BL	SIL116BL	SCTP116
R1200GS ADVENTURE	2014-2018	EVO117CL	EVO117BL	PRO117CL	PRO117BL	SIL117BL	SCTP117
R1200R/SPORT	2015-2018	EVO118CL	EVO118BL	PRO118CL	PRO118BL	SIL118BL	SCTP118
R1200GS	2013-2016	EVO119CL	EVO119BL	PRO119CL	PRO119BL	SIL119BL	SCTP119

MODELLO	ANNI	EVO SERIES		PRO SERIES		SILICONE SERIES	STONE CHIP TANK PROTECTION
		CODICE TRASPARENTE	CODICE NERO	CODICE TRASPARENTE	CODICE NERO	CODICE NERO	CODICE
G 310R	2016-	EVO120CL	EVO120BL	PRO120CL	PRO120BL	SIL120BL	SCTP120
F750/850GS/SPORT	2018-	EVO121CL	EVO121BL	PRO121CL	PRO121BL	SIL121BL	SCTP121
G310GS	2018-	EVO122CL	EVO122BL	PRO122CL	PRO122BL	SIL122BL	SCTP122
S1000RR	2019-	EVO123CL	EVO123BL	PRO123CL	PRO123BL	SIL123BL	SCTP123
R1250R	2019-	EVO124CL	EVO124BL	PRO124CL	PRO124BL	SIL124BL	SCTP124
R1250RS	2019-	EVO125CL	EVO125BL	PRO125CL	PRO125BL	SIL125BL	SCTP125
R1250RT	2019-	EVO126CL	EVO126BL	PRO126CL	PRO126BL	SIL126BL	SCTP126
R1250GS RALLYE	2019-	EVO127CL	EVO127BL	PRO127CL	PRO127BL	SIL127BL	SCTP127
R1250GS ADVENTURE	2019-	EVO128CL	EVO128BL	PRO128CL	PRO128BL	SIL128BL	SCTP128
F900R	2020-	EVO129CL	EVO129BL	PRO129CL	PRO129BL	SIL129BL	SCTP129
F900XR	2020-	EVO130CL	EVO130BL	PRO130CL	PRO130BL	SIL130BL	SCTP130
S1000XR	2020-	EVO131CL	EVO131BL	PRO131CL	PRO131BL	SIL131BL	SCTP131
S1000R	2015-2020	EVO132CL	EVO132BL	PRO132CL	PRO132BL	SIL132BL	SCTP132
S1000R	2021-	EVO133CL	EVO133BL	PRO133CL	PRO133BL	SIL133BL	SCTP133
M 1000RR	2021-	EVO134CL	EVO134BL	PRO134CL	PRO134BL	SIL134BL	SCTP134
DUCATI							
748/916/996/998	1994-2004	EVO200CL	EVO200BL	PRO200CL	PRO200BL	SIL200BL	SCTP200
848EVO/ 848SF/1098/1198	2007-2016	EVO204CL	EVO204BL	PRO204CL	PRO204BL	SIL204BL	SCTP204
899/959/1199/1299 PANIGALE	2011-2017	EVO206CL	EVO206BL	PRO206CL	PRO206BL	SIL206BL	SCTP206
749/999	2003-2006	EVO209CL	EVO209BL	PRO209CL	PRO209BL	SIL209BL	SCTP209
1200S/ST MULTISTRADA	2010-2014	EVO211CL	EVO211BL	PRO211CL	PRO211BL	SIL211BL	SCTP211
695/696/796/ 1100EVO MONSTER	2010-2014	EVO213CL	EVO213BL	PRO213CL	PRO213BL	SIL213BL	SCTP213
797/821/1200/1200S MONSTER	2014-2020	EVO216CL	EVO216BL	PRO216CL	PRO216BL	SIL216BL	SCTP216
HYPERSTRADA HYPERMOTARD SP	2013-2018	EVO217CL	EVO217BL	PRO217CL	PRO217BL	SIL217BL	SCTP217
DIAVEL	2011-2018	EVO219CL	EVO219BL	PRO219CL	PRO219BL	SIL219BL	SCTP219
1200S/1260/1260S MULTISTRADA	2015-	EVO220CL	EVO220BL	PRO220CL	PRO220BL	SIL220BL	SCTP220
SUPERSPORT	2017-	EVO221CL	EVO221BL	PRO221CL	PRO221BL	SIL221BL	SCTP221
950 MULTISTRADA	2017-	EVO222CL	EVO222BL	PRO222CL	PRO222BL	SIL222BL	SCTP222
PANIGALE V4	2018-	EVO223CL	EVO223BL	PRO223CL	PRO223BL	SIL223BL	SCTP223
PANIGALE V2	2020-	EVO224CL	EVO224BL	PRO224CL	PRO224BL	SIL224BL	SCTP224
STREETFIGHTER V4	2020-	EVO225CL	EVO225BL	PRO225CL	PRO225BL	SIL225BL	SCTP225
HYPERMOTORAD 950	2019-	EVO226CL	EVO226BL	PRO226CL	PRO226BL	SIL226BL	SCTP226
DIAVEL 1260 1260S	2019-	EVO227CL	EVO227BL	PRO227CL	PRO227BL	SIL227BL	SCTP227
V4 MULTISTRADA	2021-	EVO228CL	EVO228BL	PRO228CL	PRO228BL	SIL228BL	SCTP228
MONSTER	2021-	EVO229CL	EVO229BL	PRO229CL	PRO229BL	SIL229BL	SCTP229
V2 MULTISTRADA	2021-	EVO230CL	EVO230BL	PRO230CL	PRO230BL	SIL230BL	SCTP230
V4 MULTISTRADA PIKES PEAK	2021-	EVO231CL	EVO231BL	PRO231CL	PRO231BL	SIL231BL	SCTP231
STREETFIGHTER V2	2021-	EVO232CL	EVO232BL	PRO232CL	PRO232BL	SIL232BL	SCTP232
STREETFIGHT V4 SP	2021-	EVO233CL	EVO233BL	PRO233CL	PRO233BL	SIL233BL	SCTP233
PANIGALE V4	2022	EVO234CL	EVO234BL	PRO234CL	PRO234BL	SIL234BL	SCTP234
HONDA							
CBR250R (MC41)	2011-2013	EVO300CL	EVO300BL	PRO300CL	PRO300BL	SIL300BL	SCTP300

MODELLO	ANNI	EVO SERIES		PRO SERIES		SILICONE SERIES	STONE CHIP TANK PROTECTION
		CODICE TRASPARENTE	CODICE NERO	CODICE TRASPARENTE	CODICE NERO	CODICE NERO	CODICE
CBR600RR STEEL FRAMED	1987-1998	EVO301CL	EVO301BL	PRO301CL	PRO301BL	SIL301BL	SCTP301
CBR600 F4i	2001-2006	EVO302CL	EVO302BL	PRO302CL	PRO302BL	SIL302BL	SCTP302
CBR600F new design	2011-2016	EVO303CL	EVO303BL	PRO303CL	PRO303BL	SIL303BL	SCTP303
CBR600RR	2003-2006	EVO304CL	EVO304BL	PRO304CL	PRO304BL	SIL304BL	SCTP304
CBR600RR	2007-2012	EVO305CL	EVO305BL	PRO305CL	PRO305BL	SIL305BL	SCTP305
CBR600RR	2013-2017	EVO306CL	EVO306BL	PRO306CL	PRO306BL	SIL306BL	SCTP306
CBR1000RR	2004-2007	EVO307CL	EVO307BL	PRO307CL	PRO307BL	SIL307BL	SCTP307
CBR1000RR - ROAD	2008-2011	EVO308CL	EVO308BL	PRO308CL	PRO308BL	SIL308BL	SCTP308
CBR1000RR - RACE	2008-2011	EVO309CL	EVO309BL	PRO309CL	PRO309BL	SIL309BL	SCTP309
CBR1000RR - ROAD	2012-2016	EVO310CL	EVO310BL	PRO310CL	PRO310BL	SIL310BL	SCTP310
CBR1000RR - RACE	2012-2016	EVO311CL	EVO311BL	PRO311CL	PRO311BL	SIL311BL	SCTP311
VTR1000	2001-2006	EVO312CL	EVO312BL	PRO312CL	PRO312BL	SIL312BL	SCTP312
VFR800	2002-2013	EVO313CL	EVO313BL	PRO313CL	PRO313BL	SIL313BL	SCTP313
VFR800	2014-	EVO314CL	EVO314BL	PRO314CL	PRO314BL	SIL314BL	SCTP314
PAN EUROPEAN (ST1300)	2002-2013	EVO315CL	EVO315BL	PRO315CL	PRO315BL	SIL315BL	SCTP315
CBR1100xx (BLACKBIRD)	1997-2007	EVO316CL	EVO316BL	PRO316CL	PRO316BL	SIL316BL	SCTP316
NC700X	2013-2016	EVO317CL	EVO317BL	PRO317CL	PRO317BL	SIL317BL	SCTP317
NC700S	2013-2016	EVO318CL	EVO318BL	PRO318CL	PRO318BL	SIL318BL	SCTP318
CBR500R	2013-2018	EVO319CL	EVO319BL	PRO319CL	PRO319BL	SIL319BL	SCTP319
CB500F	2013-2018	EVO320CL	EVO320BL	PRO320CL	PRO320BL	SIL320BL	SCTP320
CBR900	1992-1999	EVO321CL	EVO321BL	PRO321CL	PRO321BL	SIL321BL	SCTP321
CBR900	2000-2001	EVO322CL	EVO322BL	PRO322CL	PRO322BL	SIL322BL	SCTP322
CB900 HORNET	2002-2007	EVO323CL	EVO323BL	PRO323CL	PRO323BL	SIL323BL	SCTP323
CBR300	2014-2016	EVO324CL	EVO324BL	PRO324CL	PRO324BL	SIL324BL	SCTP324
CBR650RR/F	2015-2018	EVO325CL	EVO325BL	PRO325CL	PRO325BL	SIL325BL	SCTP325
NC750X	2016-2020	EVO327CL	EVO327BL	PRO327CL	PRO327BL	SIL327BL	SCTP327
VFR800X CROSSRUNNER	2015-	EVO328CL	EVO328BL	PRO328CL	PRO328BL	SIL328BL	SCTP328
CRF1000L AFRICA TWIN	2015-2019	EVO329CL	EVO329BL	PRO329CL	PRO329BL	SIL329BL	SCTP329
CBR1000RR	2017-2019	EVO330CL	EVO330BL	PRO330CL	PRO330BL	SIL330BL	SCTP330
CBR250RR	2017-2020	EVO331CL	EVO331BL	PRO331CL	PRO331BL	SIL331BL	SCTP331
CRF1000L AFRICA TWIN ADVENTURE SPORT	2018-2019	EVO332CL	EVO332BL	PRO332CL	PRO332BL	SIL332BL	SCTP332
CB125R	2018-	EVO333CL	EVO333BL	PRO333CL	PRO333BL	SIL333BL	SCTP333
CBR125R	2011-2016	EVO334CL	EVO334BL	PRO334CL	PRO334BL	SIL334BL	SCTP334
CB1100EX	2017-	EVO335CL	EVO335BL	PRO335CL	PRO335BL	SIL335BL	SCTP335
CB1000R	2018-	EVO336CL	EVO336BL	PRO336CL	PRO336BL	SIL336BL	SCTP336
CB125F	2018-2020	EVO337CL	EVO337BL	PRO337CL	PRO337BL	SIL337BL	SCTP337
CB1100S	2013-2016	EVO338CL	EVO338BL	PRO338CL	PRO338BL	SIL338BL	SCTP338
MONKEY	2018-	EVO339CL	EVO339BL	PRO339CL	PRO339BL	SIL339BL	SCTP339
CB300R	2018-	EVO340CL	EVO340BL	PRO340CL	PRO340BL	SIL340BL	SCTP340
CB650R CBR650R	2019-	EVO341CL	EVO341BL	PRO341CL	PRO341BL	SIL341BL	SCTP341
CBR500RR	2019-	EVO342CL	EVO342BL	PRO342CL	PRO342BL	SIL342BL	SCTP342
CB500X	2019-	EVO343CL	EVO343BL	PRO343CL	PRO343BL	SIL343BL	SCTP343
CBR1000RR	2020-	EVO344CL	EVO344BL	PRO344CL	PRO344BL	SIL344BL	SCTP344
VFR1200	2010-2020	EVO345CL	EVO345BL	PRO345CL	PRO345BL	SIL345BL	SCTP345

MODELLO	ANNI	EVO SERIES		PRO SERIES		SILICONE SERIES	STONE CHIP TANK PROTECTION
		CODICE TRASPARENTE	CODICE NERO	CODICE TRASPARENTE	CODICE NERO	CODICE NERO	CODICE
AFRICAN TWIN	2020-	EVO346CL	EVO346BL	PRO346CL	PRO346BL	SIL346BL	SCTP346
AFRICAN TWIN ADVENTURE SPORT	2020-	EVO347CL	EVO347BL	PRO347CL	PRO347BL	SIL347BL	SCTP347
MSX125	2014-2020	EVO348CL	EVO348BL	PRO348CL	PRO348BL	SIL348BL	SCTP348
CB500F	2019-2021	EVO350CL	EVO350BL	PRO350CL	PRO350BL	SIL350BL	SCTP360
NSF250R	2012-	EVO351CL	EVO351BL	PRO351CL	PRO351BL	SIL351BL	SCTP361
CMX500 REBEL	2017-	EVO352CL	EVO352BL	PRO352CL	PRO352BL	SIL352BL	SCTP362
CMX1100 REBEL	2021-	EVO353CL	EVO353BL	PRO353CL	PRO353BL	SIL353BL	SCTP363
NC750X	2021-	EVO354CL	EVO354BL	PRO354CL	PRO354BL	SIL354BL	SCTP364
MSX125	2021-	EVO355CL	EVO355BL	PRO355CL	PRO355BL	SIL355BL	SCTP365
HUSQVARNA							
FS450	2015-2016	EVOHUS001CL	EVOHUS001BL	PROHUS001CL	PROHUS001BL	SILHUS001BL	SCTPHUS001
KAWASAKI							
NINJA 250	2008-2012	EVO400CL	EVO400BL	PRO400CL	PRO400BL	SIL400BL	SCTP400
NINJA 250SL/Z250SL new design	2014-	EVO401CL	EVO401BL	PRO401CL	PRO401BL	SIL401BL	SCTP401
NINJA300	2013-	EVO402CL	EVO402BL	PRO402CL	PRO402BL	SIL402BL	SCTP402
ZX6R	1995-1997	EVO403CL	EVO403BL	PRO403CL	PRO403BL	SIL403BL	SCTP403
ZX6R	2000-2002	EVO404CL	EVO404BL	PRO404CL	PRO404BL	SIL404BL	SCTP404
ZX6R (636)	2003-2004	EVO405CL	EVO405BL	PRO405CL	PRO405BL	SIL405BL	SCTP405
ZX6R	2007-2008	EVO406CL	EVO406BL	PRO406CL	PRO406BL	SIL406BL	SCTP406
ZX6R	2009-2012	EVO407CL	EVO407BL	PRO407CL	PRO407BL	SIL407BL	SCTP407
ZX6R (636)	2013-2016	EVO408CL	EVO408BL	PRO408CL	PRO408BL	SIL408BL	SCTP408
ZX10R	2004-2005	EVO409CL	EVO409BL	PRO409CL	PRO409BL	SIL409BL	SCTP409
ZX10R	2008-2010	EVO410CL	EVO410BL	PRO410CL	PRO410BL	SIL410BL	SCTP410
ZX10R	2011-2015	EVO411CL	EVO411BL	PRO411CL	PRO411BL	SIL411BL	SCTP411
ZX12R	2000-2006	EVO412CL	EVO412BL	PRO412CL	PRO412BL	SIL412BL	SCTP412
Z750	2007-2012	EVO413CL	EVO413BL	PRO413CL	PRO413BL	SIL413BL	SCTP413
Z800	2013-2016	EVO414CL	EVO414BL	PRO414CL	PRO414BL	SIL414BL	SCTP414
ER650F/N	2006-2011	EVO415CL	EVO415BL	PRO415CL	PRO415BL	SIL415BL	SCTP415
Z1000	2003-2006	EVO416CL	EVO416BL	PRO416CL	PRO416BL	SIL416BL	SCTP416
Z1000	2010-2013	EVO417CL	EVO417BL	PRO417CL	PRO417BL	SIL417BL	SCTP417
Z1000SX	2012-	EVO418CL	EVO418BL	PRO418CL	PRO418BL	SIL418BL	SCTP418
Z1000	2014-	EVO419CL	EVO419BL	PRO419CL	PRO419BL	SIL419BL	SCTP419
NINJA H2/H2R	2015-	EVO420CL	EVO420BL	PRO420CL	PRO420BL	SIL420BL	SCTP420
ZZR1400	2012-	EVO421CL	EVO421BL	PRO421CL	PRO421BL	SIL421BL	SCTP421
VERSYS 650	2015-	EVO422CL	EVO422BL	PRO422CL	PRO422BL	SIL422BL	SCTP422
VERSYS 1000	2015-2018	EVO423CL	EVO423BL	PRO423CL	PRO423BL	SIL423BL	SCTP423
ZX10R	2016-	EVO424CL	EVO424BL	PRO424CL	PRO424BL	SIL424BL	SCTP424
Z125	2016-2018	EVO425CL	EVO425BL	PRO425CL	PRO425BL	SIL425BL	SCTP425
Z650/NINJA 650	2017-	EVO426CL	EVO426BL	PRO426CL	PRO426BL	SIL426BL	SCTP426
Z1000	2007-2009	EVO427CL	EVO427BL	PRO427CL	PRO427BL	SIL427BL	SCTP427
Z900	2017-	EVO428CL	EVO428BL	PRO428CL	PRO428BL	SIL428BL	SCTP428
ER-6F/N	2012-2016	EVO429CL	EVO429BL	PRO429CL	PRO429BL	SIL429BL	SCTP429
ZX6R	2005-2006	EVO430CL	EVO430BL	PRO430CL	PRO430BL	SIL430BL	SCTP430
VERSYS-X 300	2017-	EVO431CL	EVO431BL	PRO431CL	PRO431BL	SIL431BL	SCTP431

MODELLO	ANNI	EVO SERIES		PRO SERIES		SILICONE SERIES	STONE CHIP TANK PROTECTION
		CODICE TRASPARENTE	CODICE NERO	CODICE TRASPARENTE	CODICE NERO	CODICE NERO	CODICE
NINJA Z400	2018-	EVO432CL	EVO432BL	PRO432CL	PRO432BL	SIL432BL	SCTP432
Z900RS / SE	2018-	EVO433CL	EVO433BL	PRO433CL	PRO433BL	SIL433BL	SCTP433
H2 SX / SX SE	2018-	EVO434CL	EVO434BL	PRO434CL	PRO434BL	SIL434BL	SCTP434
VERSYS 1000 / SE	2019-	EVO435CL	EVO435BL	PRO435CL	PRO435BL	SIL435BL	SCTP436
NINJA Z125	2019-	EVO436CL	EVO436BL	PRO436CL	PRO436BL	SIL436BL	SCTP436
ZX6R 636	2019-	EVO437CL	EVO437BL	PRO437CL	PRO437BL	SIL437BL	SCTP437
ZH2	2020-	EVO438CL	EVO438BL	PRO438CL	PRO438BL	SIL438BL	SCTP438
NINJA 1000SX	2020-	EVO439CL	EVO439BL	PRO439CL	PRO439BL	SIL439BL	SCTP439
Ninja ZX25R	2020-	EVO440CL	EVO440BL	PRO440CL	PRO440BL	SIL440BL	SCTP440
Z650RS	2021-	EVO441CL	EVO441BL	PRO441CL	PRO441BL	SIL441BL	SCTP441
KTM							
1090/1190/1290 ADVENTURE	2013-	EVO500CL	EVO500BL	PRO500CL	PRO500BL	SIL500BL	SCTP500
125/200/390 DUKE	2011-2016	EVO501CL	EVO501BL	PRO501CL	PRO501BL	SIL501BL	SCTP501
690 DUKE	2012-2019	EVO504CL	EVO504BL	PRO504CL	PRO504BL	SIL504BL	SCTP504
990 SUPER DUKE R	2005-2013	EVO505CL	EVO505BL	PRO505CL	PRO505BL	SIL505BL	SCTP505
RC8	2009-2016	EVO506CL	EVO506BL	PRO506CL	PRO506BL	SIL506BL	SCTP506
1290 SUPER DUKE R	2014-2016	EVO507CL	EVO507BL	PRO507CL	PRO507BL	SIL507BL	SCTP507
RC125/200/390	2014-2020	EVO508CL	EVO508BL	PRO508CL	PRO508BL	SIL508BL	SCTP508
1290 SUPER DUKE R	2017-2019	EVO509CL	EVO509BL	PRO509CL	PRO509BL	SIL509BL	SCTP509
1290 SUPER DUKE GT	2016-	EVO510CL	EVO510BL	PRO510CL	PRO510BL	SIL510BL	SCTP510
DUKE 125 / 390	2017-	EVO511CL	EVO511BL	PRO511CL	PRO511BL	SIL511BL	SCTP511
790 DUKE	2018-2020	EVO512CL	EVO512BL	PRO512CL	PRO512BL	SIL512BL	SCTP512
890 DUKE R	2020-	EVO513CL	EVO513BL	PRO513CL	PRO513BL	SIL513BL	SCTP513
1290 SUPERDUKE R	2020-	EVO514CL	EVO514BL	PRO514CL	PRO514BL	SIL514BL	SCTP514
890 DUKE	2021	EVO515CL	EVO515BL	PRO515CL	PRO515BL	SIL515BL	SCTP515
390 ADVENTURE	2020-	EVO516CL	EVO516BL	PRO516CL	PRO516BL	SIL516BL	SCTP516
890 ADVENTURE	2021-	EVO517CL	EVO517BL	PRO517CL	PRO517BL	SIL517BL	SCTP517
1290 SUPER ADVENTURE	2021-	EVO518CL	EVO518BL	PRO518CL	PRO518BL	SIL518BL	SCTP518
MV AGUSTA							
F3 675/800	2013-	EVO600CL	EVO600BL	PRO600CL	PRO600BL	SIL600BL	SCTP600
990R/1090RR BRUTALE	2010-2019	EVO601CL	EVO601BL	PRO601CL	PRO601BL	SIL601BL	SCTP601
F4 1000R	2010-2018	EVO602CL	EVO602BL	PRO602CL	PRO602BL	SIL602BL	SCTP602
675/800 BRUTALE	2012-2017	EVO603CL	EVO603BL	PRO603CL	PRO603BL	SIL603BL	SCTP603
DRAGSTER 800	2014-2017	EVO604CL	EVO604BL	PRO604CL	PRO604BL	SIL604BL	SCTP604
STRADALE 800	2015-2017	EVO605CL	EVO605BL	PRO605CL	PRO605BL	SIL605BL	SCTP605
BRUTALE / DRAGSTER 800RR - (Rosso RR RR SCS RC SCS)	2018-	EVO606CL	EVO606BL	PRO606CL	PRO606BL	SIL606BL	SCTP606
SUPERVELOCE 800, S, ALPINE	2021-	EVO607CL	EVO607BL	PRO607CL	PRO607BL	SIL607BL	SCTP607
TURISMO VELOCE	2021-	EVO608CL	EVO608BL	PRO608CL	PRO608BL	SIL608BL	SCTP608
BRUTALE 1000 RUSH	2020-	EVO609CL	EVO609BL	PRO609CL	PRO609BL	SIL609BL	SCTP609
NORTON							
V4 RR/SS	2019	EVONOR001CL	EVONOR001BL	PRONOR001CL	PRONOR001BL	SILNOR001BL	SCTPNOR001
SUZUKI							

MODELLO	ANNI	EVO SERIES		PRO SERIES		SILICONE SERIES	STONE CHIP TANK PROTECTION
		CODICE TRASPARENTE	CODICE NERO	CODICE TRASPARENTE	CODICE NERO	CODICE NERO	CODICE
GSXR600/750	1996-2000	EVO700CL	EVO700BL	PRO700CL	PRO700BL	SIL700BL	SCTP700
GSXR600/750 new design	2001-2003	EVO701CL	EVO701BL	PRO701CL	PRO701BL	SIL701BL	SCTP701
GSXR600/750	2004-2005	EVO702CL	EVO702BL	PRO702CL	PRO702BL	SIL702BL	SCTP702
GSXR600/750	2006-2007	EVO703CL	EVO703BL	PRO703CL	PRO703BL	SIL703BL	SCTP703
GSXR600/750	2008-2010	EVO704CL	EVO704BL	PRO704CL	PRO704BL	SIL704BL	SCTP704
GSXR600/750	2011-	EVO705CL	EVO705BL	PRO705CL	PRO705BL	SIL705BL	SCTP705
GSXR1000	2001-2004	EVO712CL	EVO712BL	PRO712CL	PRO712BL	SIL712BL	SCTP712
GSXR1000	2005-2006	EVO713CL	EVO713BL	PRO713CL	PRO713BL	SIL713BL	SCTP713
GSXR1000 new design	2007-2008	EVO714CL	EVO714BL	PRO714CL	PRO714BL	SIL714BL	SCTP714
GSXR1000 new design	2009-2016	EVO715CL	EVO715BL	PRO715CL	PRO715BL	SIL715BL	SCTP715
GSX1300R HAYABUSA	1999-	EVO716CL	EVO716BL	PRO716CL	PRO716BL	SIL716BL	SCTP716
BANDIT GSF650	2005-2009	EVO717CL	EVO717BL	PRO717CL	PRO717BL	SIL717BL	SCTP717
GSF1250S/GT BANDIT	2007-2016	EVO718CL	EVO718BL	PRO718CL	PRO718BL	SIL718BL	SCTP718
SV1000	2003-2007	EVO719CL	EVO719BL	PRO719CL	PRO719BL	SIL719BL	SCTP719
SV650	2007-2015	EVO720CL	EVO720BL	PRO720CL	PRO720BL	SIL720BL	SCTP720
VSTROM 600	2012-2016	EVO721CL	EVO721BL	PRO721CL	PRO721BL	SIL721BL	SCTP721
VSTROM 1000	2013-2019	EVO722CL	EVO722BL	PRO722CL	PRO722BL	SIL722BL	SCTP722
GSR750	2011-2016	EVO723CL	EVO723BL	PRO723CL	PRO723BL	SIL723BL	SCTP723
SFV650 GLADIUS	2010-2016	EVO724CL	EVO724BL	PRO724CL	PRO724BL	SIL724BL	SCTP724
GSX650F	2009-2016	EVO725CL	EVO725BL	PRO725CL	PRO725BL	SIL725BL	SCTP725
GSX S1000	2015-2020	EVO726CL	EVO726BL	PRO726CL	PRO726BL	SIL726BL	SCTP726
SV650	2016-	EVO727CL	EVO727BL	PRO727CL	PRO727BL	SIL727BL	SCTP727
SV650	1999-2002	EVO728CL	EVO728BL	PRO728CL	PRO728BL	SIL728BL	SCTP728
GSXR1000	2017-	EVO729CL	EVO729BL	PRO729CL	PRO729BL	SIL729BL	SCTP729
GSX-S750	2017-	EVO730CL	EVO730BL	PRO730CL	PRO730BL	SIL730BL	SCTP730
V-STROM 650	2017-	EVO731CL	EVO731BL	PRO731CL	PRO731BL	SIL731BL	SCTP731
GSX-R125/S125	2017-	EVO732CL	EVO732BL	PRO732CL	PRO732BL	SIL732BL	SCTP732
GSXR250	2018-	EVO733CL	EVO733BL	PRO733CL	PRO733BL	SIL733BL	SCTP733
KATANA	2019-	EVO734CL	EVO734BL	PRO734CL	PRO734BL	SIL734BL	SCTP734
V-STROM 250	2017-	EVO735CL	EVO735BL	PRO735CL	PRO735BL	SIL735BL	SCTP736
HAYABUSA	2021-	EVO736CL	EVO736BL	PRO736CL	PRO736BL	SIL736BL	SCTP736
V-STROM 1050	2021-	EVO737CL	EVO737BL	PRO737CL	PRO737BL	SIL737BL	SCTP736
GSX-S1000 GSX-S950	2021-	EVO738CL	EVO738BL	PRO738CL	PRO738BL	SIL738BL	SCTP738
GSX-S1000 GT	2021-	EVO739CL	EVO739BL	PRO739CL	PRO739BL	SIL739BL	SCTP739
TRIUMPH							
DAYTONA 675/ STREET TRIPLE	2006-2012	EVO800CL	EVO800BL	PRO800CL	PRO800BL	SIL800BL	SCTP800
DAYTONA 675/765 STREET TRIPLE	2013-	EVO801CL	EVO801BL	PRO801CL	PRO801BL	SIL801BL	SCTP801
SPEED TRIPLE 1050	2011-2015	EVO804CL	EVO804BL	PRO804CL	PRO804BL	SIL804BL	SCTP804
SPRINT ST/GT	2005-2016	EVO805CL	EVO805BL	PRO805CL	PRO805BL	SIL805BL	SCTP805
DAYTONA 955i	2002-2006	EVO807CL	EVO807BL	PRO807CL	PRO807BL	SIL807BL	SCTP807
TIGER 800	2015-	EVO808CL	EVO808BL	PRO808CL	PRO808BL	SIL808BL	SCTP808
TIGER EXPLORER 1200	2012-	EVO809CL	EVO809BL	PRO809CL	PRO809BL	SIL809BL	SCTP809
SPEED TRIPLE	2005-2010	EVO810CL	EVO810BL	PRO810CL	PRO810BL	SIL810BL	SCTP810
SPEED TRIPLE	2016-	EVO811CL	EVO811BL	PRO811CL	PRO811BL	SIL811BL	SCTP811

MODELLO	ANNI	EVO SERIES		PRO SERIES		SILICONE SERIES	STONE CHIP TANK PROTECTION
		CODICE TRASPARENTE	CODICE NERO	CODICE TRASPARENTE	CODICE NERO	CODICE NERO	CODICE
SCRAMBLER 1200	2019-	EV0812CL	EV0812BL	PRO812CL	PRO812BL	SIL812BL	SCTP812
BONNEVILLE BOBBER	2017-	EV0813CL	EV0813BL	PRO813CL	PRO813BL	SIL813BL	SCTP813
SPEED TWIN	2019-	EV0814CL	EV0814BL	PRO814CL	PRO814BL	SIL814BL	SCTP814
STREET TWIN	2016-	EV0815CL	EV0815BL	PRO815CL	PRO815BL	SIL815BL	SCTP815
THRUXTON 1200 1200R	2016-	EV0816CL	EV0816BL	PRO816CL	PRO816BL	SIL816BL	SCTP816
TIGER SPORT 1050	2016-	EV0817CL	EV0817BL	PRO817CL	PRO817BL	SIL817BL	SCTP817
SPEED TRIPLE 1200 RS	2021-	EV0818CL	EV0818BL	PRO818CL	PRO818BL	SIL818BL	SCTP818
TIGER 900	2020-	EV0819CL	EV0819BL	PRO819CL	PRO819BL	SIL819BL	SCTP819
TIGER 850 SPORT	2021-	EV0820CL	EV0820BL	PRO820CL	PRO820BL	SIL820BL	SCTP820
SPEED TRIPLE 1200 RR	2022-	EV0821CL	EV0821BL	PRO821CL	PRO821BL	SIL821BL	SCTP821
UNIVERSALE							
2X FOGLI	305x155	EVOSHEETSCL	EVOSHEETSBL	PROSHEETSCL	PROSHEETSBL	SILSHEETSBL	SCTPSHEETS
LARGE UNIVERSAL		EVOLARGEUNICL	EVOLARGEUNIBL	PROLARGEUNICL	PROLARGEUNIBL	SILLARGEUNIBL	SCTPLARGEUNI
RIDGED	-	EVORIDGEDUNICL	EVORIDGEDUNIBL	PRORIDGEDCL	PRORIDGEDBL	SILRIDGEDUNIBL	SCTPRIDGEDUNI
YAMAHA							
YZF-R125	2008-2018	EV0900CL	EV0900BL	PRO900CL	PRO900BL	SIL900BL	SCTP900
YZF- R1	2002-2003	EV0901CL	EV0901BL	PRO901CL	PRO901BL	SIL901BL	SCTP901
YZF-R1	2004-2006	EV0902CL	EV0902BL	PRO902CL	PRO902BL	SIL902BL	SCTP902
YZF-R1	2007-2008	EV0903CL	EV0903BL	PRO903CL	PRO903BL	SIL903BL	SCTP903
YZF-R1	2009-2014	EV0904CL	EV0904BL	PRO904CL	PRO904BL	SIL904BL	SCTP904
YZF-R6	1999-2002	EV0905CL	EV0905BL	PRO905CL	PRO905BL	SIL905BL	SCTP905
YZF-R6	2003-2005	EV0906CL	EV0906BL	PRO906CL	PRO906BL	SIL906BL	SCTP906
YZF-R6	2006-2007	EV0907CL	EV0907BL	PRO907CL	PRO907BL	SIL907BL	SCTP907
YZF-R6	2008-2016	EV0909CL	EV0909BL	PRO909CL	PRO909BL	SIL909BL	SCTP909
FZS 1000 FAZER	2001-2005	EV0910CL	EV0910BL	PRO910CL	PRO910BL	SIL910BL	SCTP910
FZ1 FAZER	2006-2016	EV0911CL	EV0911BL	PRO911CL	PRO911BL	SIL911BL	SCTP911
FZ6 FAZER	2004-2009	EV0912CL	EV0912BL	PRO912CL	PRO912BL	SIL912BL	SCTP912
FZ8 FAZER	2010-2015	EV0913CL	EV0913BL	PRO913CL	PRO913BL	SIL913BL	SCTP913
MT-07	2014-2017	EV0914CL	EV0914BL	PRO914CL	PRO914BL	SIL914BL	SCTP914
MT-09	2013-2020	EV0915CL	EV0915BL	PRO915CL	PRO915BL	SIL915BL	SCTP915
XJ6	2010-2016	EV0916CL	EV0916BL	PRO916CL	PRO916BL	SIL916BL	SCTP916
MT-125	2014-2019	EV0917CL	EV0917BL	PRO917CL	PRO917BL	SIL917BL	SCTP917
YZF-R25/R3	2014-2018	EV0918CL	EV0918BL	PRO918CL	PRO918BL	SIL918BL	SCTP918
YZF-R1/R1M	2015-2019	EV0919CL	EV0919BL	PRO919CL	PRO919BL	SIL919BL	SCTP919
MT-03	2006-2015	EV0920CL	EV0920BL	PRO920CL	PRO920BL	SIL920BL	SCTP920
MT-09 TRACER / 900 TRACER GT	2015-2020	EV0921CL	EV0921BL	PRO921CL	PRO921BL	SIL921BL	SCTP921
SUPER TENERE	2011-	EV0922CL	EV0922BL	PRO922CL	PRO922BL	SIL922BL	SCTP922
FJR 1300	2013-	EV0923CL	EV0923BL	PRO923CL	PRO923BL	SIL923BL	SCTP923
XSR 900	2016-	EV0925CL	EV0925BL	PRO925CL	PRO925BL	SIL925BL	SCTP925
XJR 1300	2015-2017	EV0926CL	EV0926BL	PRO926CL	PRO926BL	SIL926BL	SCTP926
MT-10	2016-	EV0927CL	EV0927BL	PRO927CL	PRO927BL	SIL927BL	SCTP927
YZF-R6	2017-	EV0928CL	EV0928BL	PRO928CL	PRO928BL	SIL928BL	SCTP928
TRACER 700	2017-2019	EV0929CL	EV0929BL	PRO929CL	PRO929BL	SIL929BL	SCTP929
MT-03	2016-2019	EV0930CL	EV0930BL	PRO930CL	PRO930BL	SIL930BL	SCTP930

MODELLO	ANNI	EVO SERIES		PRO SERIES		SILICONE SERIES	STONE CHIP TANK PROTECTION
		CODICE TRASPARENTE	CODICE NERO	CODICE TRASPARENTE	CODICE NERO	CODICE NERO	CODICE
XSR 700	2015-	EV0931CL	EV0931BL	PR0931CL	PR0931BL	SIL931BL	SCTP931
NIKEN	2018-	EV0932CL	EV0932BL	PR0932CL	PR0932BL	SIL932BL	SCTP932
MT-07	2018-2020	EV0933CL	EV0933BL	PR0933CL	PR0933BL	SIL933BL	SCTP933
YZF-R3	2019-	EV0934CL	EV0934BL	PR0934CL	PR0934BL	SIL934BL	SCTP934
YZF-R125	2019-	EV0935CL	EV0935BL	PR0935CL	PR0935BL	SIL935BL	SCTP936
XTZ700 TENERE	2019-	EV0936CL	EV0936BL	PR0936CL	PR0936BL	SIL936BL	SCTP936
YZF-R1/R1M	2020-	EV0937CL	EV0937BL	PR0937CL	PR0937BL	SIL937BL	SCTP937
TRACER 7	2021-	EV0938CL	EV0938BL	PR0938CL	PR0938BL	SIL938BL	SCTP938
MT-03	2020-	EV0939CL	EV0939BL	PR0939CL	PR0939BL	SIL939BL	SCTP939
MT-125	2020-	EV0940CL	EV0940BL	PR0940CL	PR0940BL	SIL940BL	SCTP940
MT-07	2021-	EV0941CL	EV0941BL	PR0941CL	PR0941BL	SIL941BL	SCTP941
TRACER 9 / GT	2021-	EV0942CL	EV0942BL	PR0942CL	PR0942BL	SIL942BL	SCTP942
TRACER 700	2020	EV0943CL	EV0943BL	PR0943CL	PR0943BL	SIL943BL	SCTP943
MT-09	2021-	EV0944CL	EV0944BL	PR0944CL	PR0944BL	SIL944BL	SCPT944
R7	2021-	EV0945CL	EV0945BL	PR0945CL	PR0945BL	SIL945BL	SCTP945
XSR125	2021-	EV0946CL	EV0946BL	PR0946CL	PR0946BL	SIL946BL	SCTP946

PROTEZIONE SERBATOIO INTEGRALE



MODELLO	ANNI	CODICE
APRILIA		
RS 660 / TUONO 660	2021-	WRAPR001
BMW		
S1000RR	2015-2018	WRAPBMW001
S1000R	2015-2020	WRAPBMW002
HONDA		
CBR1000RR	2012-2016	WRAPHON001
CBR1000RR	2017-2019	WRAPHON002
KAWASAKI		
ZX10R	2016-	WRAPKAW001
ZX6R	2019-	WRAPKAW002
Z650	2017-	WRAPKAW003
Z900	2017-	WRAPKAW004

MODELLO	ANNI	CODICE
VERSYS 1000	2015-2018	WRAPKAW005
NINJA 250/400	2018-	WRAPKAW006
ZH2	2020-	WRAPKAW007
MV AGUSTA		
DRAGSTER 800RR	2014-2017	WRAPMVA001
SUZUKI		
GSXR1000	2017-	WRAPSUZ001
TRIUMPH		
STREET TRIPLE 675/765	2013-	WRAPTRI001
YAMAHA		
YZF-R1	2015-2019	WRAPYAM001
YZF-R3	2015-2018	WRAPYAM002
YZF-R6	2017-	WRAPYAM003

CENTRE TANK PADS



	MODELLO	CODICE
--	---------	--------

DESIGN A



EVO TRASPARENTE	EVOCENTREPADA CL
EVO NERO	EVOCENTREPADA BL
PRO TRASPARENTE	PROCENTREPADA CL
PRO NERO	PROCENTREPADA BL
SILICONE	SILCENTREPADA BL
SCTP	SCTPCENTREPA DA

	MODELLO	CODICE
--	---------	--------

DESIGN B



EVO TRASPARENTE	EVOCENTREPAD BCL
EVO NERO	EVOCENTREPAD BL
PRO TRASPARENTE	PROCENTREPAD BCL
PRO NERO	PROCENTREPAD BL
SILICONE	SILCENTREPAD BL
SCTP	SCTPCENTREPA DB

	MODELLO	CODICE
--	---------	--------

DESIGN C



EVO TRASPARENTE	EVOCENTREPAD CCL
EVO NERO	EVOCENTREPAD CBL
PRO TRASPARENTE	PROCENTREPAD CCL
PRO NERO	PROCENTREPAD CBL
SILICONE	SILCENTREPAD CBL
SCTP	SCTPCENTREPA DC

	MODELLO	CODICE
--	---------	--------

DESIGN D



EVO TRASPARENTE	EVOCENTREPAD DCL
EVO NERO	EVOCENTREPAD DBL
PRO TRASPARENTE	PROCENTREPAD DCL
PRO NERO	PROCENTREPAD DBL
SILICONE	SILCENTREPAD DBL
SCTP	SCTPCENTREPA DD

	MODELLO	CODICE
--	---------	--------

DESIGN E



EVO TRASPARENTE	EVOCENTREPA DECL
EVO NERO	EVOCENTREPA DEBL
PRO TRASPARENTE	PROCENTREPA DECL
PRO NERO	PROCENTREPA DEBL
SILICONE	SILCENTREPA DEBL
SCTP	SCTPCENTREPA DE

	MODELLO	CODICE
--	---------	--------

DESIGN F



EVO TRASPARENTE	EVOCENTREPA DFCL
EVO NERO	EVOCENTREPA DFBL
PRO TRASPARENTE	PROCENTREPA DFCL
PRO NERO	PROCENTREPA DFBL
SILICONE	SILCENTREPA DFBL
SCTP	SCTPCENTREPA DF

	MODELLO	CODICE
--	---------	--------

DESIGN G



EVO TRASPARENTE	EVOCENTREPA DGCL
EVO NERO	EVOCENTREPA DGBL
PRO TRASPARENTE	PROCENTREPA DGCL
PRO NERO	PROCENTREPA DGBL
SILICONE	SILCENTREPA DGBL
SCTP	SCTPCENTREPA DG

	MODELLO	CODICE
--	---------	--------

DESIGN H



EVO TRASPARENTE	EVOCENTREPA DHCL
EVO NERO	EVOCENTREPA DHBL
PRO TRASPARENTE	PROCENTREPA DHCL
PRO NERO	PROCENTREPA DHBL
SILICONE	SILCENTREPA DHBL
SCTP	SCTPCENTREPA DH

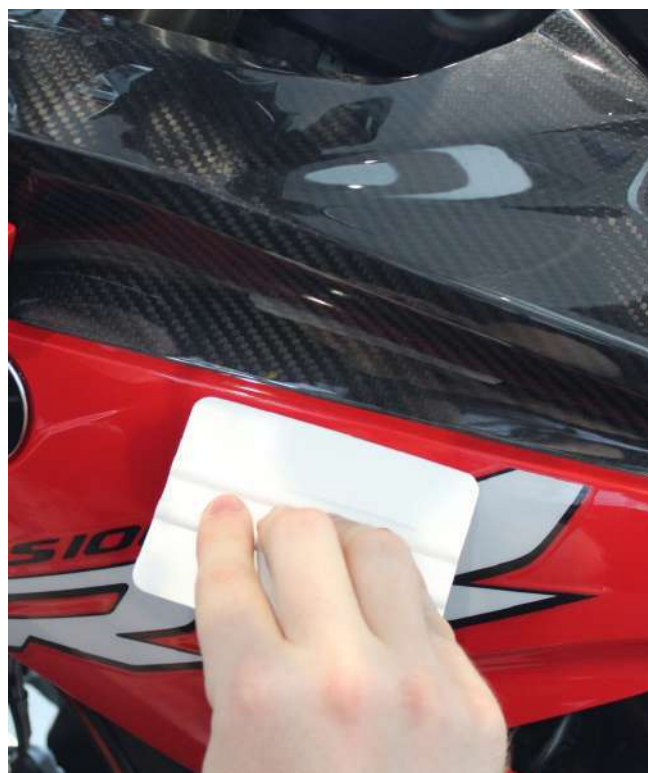

Speciale protezione in poliuretano trasparente molto flessibile ed ultrasottile, ideale per proteggere le moto da graffi dovuti a sfregamenti e piccoli urti che, a lungo andare, possono danneggiare la vernice.

Questa pellicola adesiva protegge anche dagli effetti corrosivi del sale, catrame e pulviscolo che sono in grado di ridurre il valore del mezzo.

È studiata specificatamente per i vari modelli di moto, in questo modo si riesce ad adattare alla perfezione alle linee e forme della carena. Infatti il film di poliuretano consente la perfetta aderenza anche sulle curve della carenatura e sugli spigoli più difficili. Facile da posizionare, grazie ai kit pre-tagliati, ed ultra resistente, è garantita contro l'ingiallimento precoce, la rottura e tutti i danni causati dagli agenti atmosferici o dal pietrisco stradale.

Disponibile in versione opaca e in versione lucida. Entrambe le versioni forniscono la protezione definitiva, aggiungendo un elegante finish lucido o un perfetto look opaco.

MODELLO	ANNI	LUCIDO/ OPACO	CODICE
APRILIA			
TUONO V4	2011-2014	Lucido Opaco	GUARDAPR002 GUARDAPR002M
RSV4	2015-2020	Lucido Opaco	GUARDAPR003 GUARDAPR003M
TUONO V4	2015-2017	Lucido Opaco	GUARDAPR004 GUARDAPR004M
RSV4	2021-	Lucido Opaco	GUARDAPR005 GUARDAPR005M
TUONO 660	2021-	Lucido Opaco	GUARDAPR006 GUARDAPR006M
RS 660	2021-	Lucido Opaco	GUARDAPR007 GUARDAPR007M
TUONO V4	2021-	Lucido Opaco	GUARDAPR008 GUARDAPR008M
BMW			
R1200GS	2014-2016	Lucido Opaco	GUARDBMW001 GUARDBMW001M

MODELLO	ANNI	LUCIDO/ OPACO	CODICE
S1000RR	2009-2014	Lucido Opaco	GUARDBMW002 GUARDBMW002M
S1000RR	2015-2018	Lucido Opaco	GUARDBMW003 GUARDBMW003M
HP4	2009-2014	Lucido Opaco	GUARDBMW004 GUARDBMW004M
HP4	2015-2018	Lucido Opaco	GUARDBMW005 GUARDBMW005M
S1000XR	2015-2019	Lucido Opaco	GUARDBMW006 GUARDBMW006M
R1200RT	2014-2018	Lucido Opaco	GUARDBMW007 GUARDBMW007M
S1000RR	2019-	Lucido Opaco	GUARDBMW008 GUARDBMW008M
S1000XR	2020-	Lucido Opaco	GUARDBMW009 GUARDBMW009M
F900XR	2020-	Lucido Opaco	GUARDBMW010 GUARDBMW010M
M1000RR	2021-	Lucido Opaco	GUARDBMW011 GUARDBMW011M

MODELLO	ANNI	LUCIDO/ OPACO	CODICE
S1000R	2021-	Lucido Opaco	GUARDBMW012 GUARDBMW012M
R1250RT	2019-2020	Lucido Opaco	GUARDBMW013 GUARDBMW013M
R1250RT	2021-	Lucido Opaco	GUARDBMW014 GUARDBMW014M
DUCATI			
1299 PANIGALE	2015-2017	Lucido Opaco	GUARDDUC001 GUARDDUC001M
DIAVEL	2011-2018	Lucido Opaco	GUARDDUC002 GUARDDUC002M
MULTISTRADA	2015-2017	Lucido Opaco	GUARDDUC003 GUARDDUC003M
1199 PANIGALE	2012-2017	Lucido Opaco	GUARDDUC004 GUARDDUC004M
899 PANIGALE	2013-2017	Lucido Opaco	GUARDDUC005 GUARDDUC005M
959 PANIGALE	2016-2017	Lucido Opaco	GUARDDUC006 GUARDDUC006M
SUPERSPORT	2017-2020	Lucido Opaco	GUARDDUC007 GUARDDUC007M
V4 PANIGALE	2018-2019	Lucido Opaco	GUARDDUC008 GUARDDUC008M
MULTISTRADA 950	2017-	Lucido Opaco	GUARDDUC009 GUARDDUC009M
MULTISTRADA 1260 MULTISTRADA 1260S	2018-2020	Lucido Opaco	GUARDDUC010 GUARDDUC010M
MULTISTRADA 1260 PIKES PEAK	2018-2020	Lucido Opaco	GUARDDUC011 GUARDDUC011M
V2 PANIGALE	2020-	Lucido Opaco	GUARDDUC012 GUARDDUC012M
V4 MULTISTRADA	2021-	Lucido Opaco	GUARDDUC013 GUARDDUC013M
V4 PANIGALE	2020-	Lucido Opaco	GUARDDUC014 GUARDDUC014M
MONSTER	2021-	Lucido Opaco	GUARDDUC015 GUARDDUC015M
SUPERSPORT 950	2021-	Lucido Opaco	GUARDDUC016 GUARDDUC016M
STREETFIGHTER V4	2020-	Lucido Opaco	GUARDDUC017 GUARDDUC017M
STREETFIGHTER V4 SP	2022-	Lucido Opaco	GUARDDUC018 GUARDDUC018M
MULTISTRADA V2	2021-	Lucido Opaco	GUARDDUC019 GUARDDUC019M
STREETFIGHTER V2	2021-	Lucido Opaco	GUARDDUC020 GUARDDUC020M
HONDA			
CBR1000RR	2012-2016	Lucido Opaco	GUARDHON002 GUARDHON002M
CBR650R/F	2015-2018	Lucido Opaco	GUARDHON004 GUARDHON004M
CBR1000RR	2008-2011	Lucido Opaco	GUARDHON005 GUARDHON005M
CBR1000RR	2017-2019	Lucido Opaco	GUARDHON006 GUARDHON006M

MODELLO	ANNI	LUCIDO/ OPACO	CODICE
CBR600RR	2013-2017	Lucido Opaco	GUARDHON007 GUARDHON007M
VFR800	2014-2017	Lucido Opaco	GUARDHON008 GUARDHON008M
CRF1000L AFRICA TWIN	2016-2019	Lucido Opaco	GUARDHON009 GUARDHON009M
CRF1000L AFRICA TWIN ADVENTURE SPORT	2018-2019	Lucido Opaco	GUARDHON010 GUARDHON010M
CBR1000RR	2020-	Lucido Opaco	GUARDHON011 GUARDHON011M
AFRICAN TWIN	2020-	Lucido Opaco	GUARDHON012 GUARDHON012M
AFRICA TWIN ADVENTURE SPORTS	2020-	Lucido Opaco	GUARDHON013 GUARDHON013M
GOLDWING	2020-	Lucido Opaco	GUARDHON014 GUARDHON014M
BAGGER	2020	Lucido Opaco	GUARDHON015 GUARDHON015M
NC750X	2016-2020	Lucido Opaco	GUARDHON016 GUARDHON016M
CBR650R/F	2019-	Lucido Opaco	GUARDHON017 GUARDHON017M
NSF250R	2012-	Lucido Opaco	GUARDHON018 GUARDHON018M
KAWASAKI			
ER6F	2012-2016	Lucido Opaco	GUARDKAW001 GUARDKAW001M
GTR1400	2010-2016	Lucido Opaco	GUARDKAW002 GUARDKAW002M
Z800	2013-2016	Lucido Opaco	GUARDKAW003 GUARDKAW003M
Z1000	2014-2017	Lucido Opaco	GUARDKAW004 GUARDKAW004M
Z1000SX	2014-2016	Lucido Opaco	GUARDKAW005 GUARDKAW005M
ZX6R (636)	2013-2016	Lucido Opaco	GUARDKAW006 GUARDKAW006M
ZX10R	2011-2015	Lucido Opaco	GUARDKAW007 GUARDKAW007M
ZZR1400	2012-2019	Lucido Opaco	GUARDKAW008 GUARDKAW008M
VERSYS 650	2015-2017	Lucido Opaco	GUARDKAW009 GUARDKAW009M
ZX10R	2016-2018	Lucido Opaco	GUARDKAW010 GUARDKAW010M
NINJA H2	2015-2018	Lucido Opaco	GUARDKAW011 GUARDKAW011M
Z1000SX	2017-	Lucido Opaco	GUARDKAW012 GUARDKAW012M
NINJA 650	2017-	Lucido Opaco	GUARDKAW013 GUARDKAW013M
Z900	2017-2019	Lucido Opaco	GUARDKAW014 GUARDKAW014M
VERSYS 1000	2015-2018	Lucido Opaco	GUARDKAW015 GUARDKAW015M
NINJA H2 SX	2018-	Lucido Opaco	GUARDKAW016 GUARDKAW016M

MODELLO	ANNI	LUCIDO/ OPACO	CODICE
NINJA 250/400	2018-	Lucido Opaco	GUARDKAW017 GUARDKAW017M
Z900RS CAFÉ	2017-	Lucido Opaco	GUARDKAW018 GUARDKAW018M
Z900RS	2017-	Lucido Opaco	GUARDKAW019 GUARDKAW019M
VERSYS 1000	2019-	Lucido Opaco	GUARDKAW020 GUARDKAW020M
ZX6R (636)	2019-	Lucido Opaco	GUARDKAW021 GUARDKAW021M
ZH2	2020-	Lucido Opaco	GUARDKAW022 GUARDKAW022M
NINJA 1000SX	2020-	Lucido Opaco	GUARDKAW023 GUARDKAW023M
Z900	2020-	Lucido Opaco	GUARDKAW024 GUARDKAW024M
ZX-10RR	2021-	Lucido Opaco	GUARDKAW025 GUARDKAW025M
ZX-10R	2021-	Lucido Opaco	GUARDKAW026 GUARDKAW026M
Z650RS	2021-	Lucido Opaco	GUARDKAW027 GUARDKAW027M
KTM			
1290 SUPERDUKE	2014-2016	Lucido Opaco	GUARDKTM001 GUARDKTM001M
125 DUKE	2011-2016	Lucido Opaco	GUARDKTM002 GUARDKTM002M
390 DUKE	2013-2016	Lucido Opaco	GUARDKTM003 GUARDKTM003M
1290 SUPERDUKE GT	2016-2018	Lucido Opaco	GUARDKTM004 GUARDKTM004M
790 DUKE	2018-	Lucido Opaco	GUARDKTM005 GUARDKTM005M
890 DUKE R	2021-	Lucido Opaco	GUARDKTM006 GUARDKTM006M
1290 SUPER DUKE R	2021-	Lucido Opaco	GUARDKTM007 GUARDKTM007M
1290 SUPER DUKE GT	2021-	Lucido Opaco	GUARDKTM008 GUARDKTM008M
890 DUKE	2021-	Lucido Opaco	GUARDKTM009 GUARDKTM009M
SUZUKI			
GSXR600/750	2011-2018	Lucido Opaco	GUARDSUZ001 GUARDSUZ001M
GSXR1000	2009-2016	Lucido Opaco	GUARDSUZ002 GUARDSUZ002M
GSX-S1000F	2015-2017	Lucido Opaco	GUARDSUZ003 GUARDSUZ003M
GSXR1000	2017-	Lucido Opaco	GUARDSUZ004 GUARDSUZ004M
HAYABUSA	2021-	Lucido Opaco	GUARDSUZ005 GUARDSUZ005M
TRIUMPH			
1050 SPEED TRIPLE	2011-2015	Lucido Opaco	GUARDTRI001 GUARDTRI001M
SPRINT GT	2010-2017	Lucido Opaco	GUARDTRI002 GUARDTRI002M

MODELLO	ANNI	LUCIDO/ OPACO	CODICE
675 STREET TRIPLE	2013-2016	Lucido Opaco	GUARDTRI003 GUARDTRI003M
675 DAYTONA	2013-2016	Lucido Opaco	GUARDTRI004 GUARDTRI004M
1050 SPEED TRIPLE RS	2018-	Lucido Opaco	GUARDTRI005 GUARDTRI005M
1050 SPEED TRIPLE	2016-2017	Lucido Opaco	GUARDTRI006 GUARDTRI006M
SPEED TRIPLE 1200 RS	2021-	Lucido Opaco	GUARDTRI007 GUARDTRI007M
TIGER 900 GT	2020-	Lucido Opaco	GUARDTRI008 GUARDTRI008M
TIGER 850 SPORT	2021-	Lucido Opaco	GUARDTRI009 GUARDTRI009M
STREET TRIPLE	2020-	Lucido Opaco	GUARDTRI010 GUARDTRI010M
TIGER900 RALLY RALLY PRO	2020-	Lucido Opaco	GUARDTRI011 GUARDTRI011M
UNIVERSAL			
STANDARD		Lucido Opaco	GUARDUNI001 GUARDUNI001M
LARGE		Lucido Opaco	GUARDUNI002 GUARDUNI002M
YAMAHA			
YZF-R1	2015-2019	Lucido Opaco	GUARDYAM001 GUARDYAM001M
YZF- R3/R25	2015-2018	Lucido Opaco	GUARDYAM002 GUARDYAM002M
YZF-R6	2008-2016	Lucido Opaco	GUARDYAM003 GUARDYAM003M
YZF-R125	2014-2018	Lucido Opaco	GUARDYAM004 GUARDYAM004M
YZF-R1 M	2015-2019	Lucido Opaco	GUARDYAM005 GUARDYAM005M
FJR1300A	2014-2020	Lucido Opaco	GUARDYAM006 GUARDYAM006M
FJR1300AE/AS	2014-2020	Lucido Opaco	GUARDYAM007 GUARDYAM007M
YZF-R6	2017-	Lucido Opaco	GUARDYAM008 GUARDYAM008M
YZF-R3/R25	2019-	Lucido Opaco	GUARDYAM009 GUARDYAM009M
YZF-R1	2020-	Lucido Opaco	GUARDYAM010 GUARDYAM010M
YZF-R1M	2020-	Lucido Opaco	GUARDYAM011 GUARDYAM011M
TRACER 7 / GT	2021-	Lucido Opaco	GUARDYAM012 GUARDYAM012M
MT-10 / SP	2020	Lucido Opaco	GUARDYAM013 GUARDYAM013M
R7	2021	Lucido Opaco	GUARDYAM014 GUARDYAM014M



I tubi in silicone sono un'evoluzione essenziale per il sistema di raffreddamento OEM. Sono progettati per resistere a temperature estreme e pressioni osservate su moto ad alte prestazioni. Realizzati in gomma silconica con un rinforzo in poliestere a 5 strati che offre un'estrema resistenza alla perforazione. Raccomandiamo l'installazione di tutti i kit di tubi in silicone con i kit di morsetti, realizzati in acciaio inossidabile W4 di grado marino con oltre 240 ore di test di resistenza alla corrosione.

MODELLO	ANNI	TUBI IN SILICONE		MORSETTI	
		COLORE	CODICE	COLORE	CODICE
BMW					
S1000RR	2009-2018	Nero Blu Rosso	HOSEBMW001 HOSEBMW001BLUE HOSEBMW001RED	Silver	CLAMPBMW001
S1000RR HP4	2013-2014	Nero Blu Rosso	HOSEBMW002 HOSEBMW002BLUE HOSEBMW002RED	Silver	CLAMPBMW002
S1000RR	2019-	Nero Blu Rosso	HOSEBMW003 HOSEBMW003BLUE HOSEBMW003RED	Silver	CLAMPBMW003
M1000 RR	2021-	Nero Blu Rosso	HOSEBMW004 HOSEBMW004BLUE HOSEBMW004RED	Silver	CLAMPBMW004
DUCATI					
899/R	2013-2015	Nero Blu Rosso	HOSE Duc001 HOSE Duc001BLUE HOSE Duc001RED	Silver	CLAMP Duc001
1098 R/S	2007-2009	Nero Blu Rosso	HOSE Duc002 HOSE Duc002BLUE HOSE Duc002RED	Silver	CLAMP Duc002
V4/S/SPECIALE	2017-	Nero Blu Rosso	HOSE Duc003 HOSE Duc003BLUE HOSE Duc003RED	Silver	CLAMP Duc003
959/CORSE	2016-2019	Nero Blu Rosso	HOSE Duc004 HOSE Duc004BLUE HOSE Duc004RED	Silver	CLAMP Duc004
1199 R/S/SUPERLEGGERA	2012-2014	Nero Blu Rosso	HOSE Duc005 HOSE Duc005BLUE HOSE Duc005RED	Silver	CLAMP Duc005

MODELLO	ANNI	TUBI IN SILICONE		MORSETTI	
		COLORE	CODICE	COLORE	CODICE
1299 R/R FE/S	2015-2019	Nero Blu Rosso	HOSEUDUC006 HOSEUDUC006BLUE HOSEUDUC006RED	Silver	CLAMPDUC006
PANIGALE V2	2020-	Nero Blu Rosso	HOSEUDUC007 HOSEUDUC007BLUE HOSEUDUC007RED	Silver	CLAMPDUC007
HONDA					
CBR 600RR	2007-2020	Nero Blu Rosso	HOSEHON001 HOSEHON001BLUE HOSEHON001RED	Silver	CLAMPHON001
KAWASAKI					
ER6N	2006-2017	Nero Blu Rosso Verde	HOSEKAW001 HOSEKAW001BLUE HOSEKAW001RED HOSEKAW001GREEN	Silver	CLAMPKAW001
ZX6R ROAD	2009-2021	Nero Blu Rosso Verde	HOSEKAW003 HOSEKAW003BLUE HOSEKAW003RED HOSEKAW003GREEN	Silver	CLAMPKAW003
ZX10R/SE/KRT/RR ROAD	2016-2020	Nero Blu Rosso Verde	HOSEKAW005 HOSEKAW005BLUE HOSEKAW005RED HOSEKAW005GREEN	Silver	CLAMPKAW005
ZX6R RACE	2009-2021	Nero Blu Rosso Verde	HOSEKAW006 HOSEKAW006BLUE HOSEKAW006RED HOSEKAW006GREEN	Silver	CLAMPKAW006
ZX10R/SE/KRT/RR RACE	2016-2020	Nero Blu Rosso Verde	HOSEKAW007 HOSEKAW007BLUE HOSEKAW007RED HOSEKAW007GREEN	Silver	CLAMPKAW007
SUZUKI					
GSXR600/750	2011-2021	Nero Blu Rosso	HOSESUZ003 HOSESUZ003BLUE HOSESUZ003RED	Silver	CLAMPSUZ003
GSXR1000	2009-2016	Nero Blu Rosso	HOSESUZ002 HOSESUZ002BLUE HOSESUZ002RED	Silver	CLAMPSUZ002
GSXR1000	2017-	Nero Blu Rosso	HOSESUZ005 HOSESUZ005BLUE HOSESUZ005RED	Silver	CLAMPSUZ005
SV650	2003-2014	Nero Blu Rosso	HOSESUZ001 HOSESUZ001BLUE HOSESUZ001RED	Silver	CLAMPSUZ001
YAMAHA					
YZF-R6 RACE	2006-	Nero Blu Rosso	HOSEYAM001 HOSEYAM001BLUE HOSEYAM001RED	Silver	CLAMPYAM001
YZF-R1/R1M	2015-	Nero Blu Rosso	HOSEYAM002 HOSEYAM002BLUE HOSEYAM002RED	Silver	CLAMPYAM002
YZF-R6 ROAD	2006-	Nero Blu Rosso	HOSEYAM003 HOSEYAM003BLUE HOSEYAM003RED	Silver	CLAMPYAM003
YZF-R25/R3	2015-	Nero Blu Rosso	HOSEYAM004 HOSEYAM004BLUE HOSEYAM004RED	Silver	CLAMPYAM004
MT-10/SP	2016-2021	Nero Blu Rosso	HOSEYAM005 HOSEYAM005BLUE HOSEYAM005RED	Silver	CLAMPYAM005



La protezione strumentazione è l'aggiunta perfetta alla pellicola protettiva e, grazie alle sue proprietà antigraffio, offre una copertura dello schermo ottimale.

Adatta sia per schermi LCD che TFT, una volta posizionata è praticamente invisibile ma del tutto necessaria per la massima protezione del delicato schermo.

Il kit fornito comprende: 1 protezione, 1 spatola, 1 flacone di soluzione (a cui aggiungere acqua) e 1 salviettina Eazi-Grip.

MODELLO	ANNI	CODICE
APRILIA		
RSV4	2010-2016	DASHAPR001
DORSODURO 750	2008-2015	DASHAPR002
MANA 850 GT	2007-	DASHAPR003
SHIVER 750	2008-	DASHAPR004
TUONO V4 1100	2011-2016	DASHAPR005
RSV4	2017-2020	DASHAPR006
TUONO V4 1100	2017-2020	DASHAPR007
SHIVER 900	2017-	DASHAPR008
DORSODURO 900	2017-	DASHAPR009
RSV1000	2004-2010	DASHAPR010
DORSODURO 1200	2011-	DASHAPR011
TUONO 660 / RS660	2021-	DASHAPR012
RSV4 & TUONO V4	2021-	DASHAPR013
RS 125 TUONO 125	2021-	DASHAPR014
TUAREG 660	2021-	DASHAPR015
BMW		
S1000RR	2009-2014	DASHBMW001
HP4	2009-2014	DASHBMW002
S1000RR	2015-2018	DASHBMW003
S1000R	2015-2020	DASHBMW004
S1000XR	2015-2019	DASHBMW005
C400 X/GT	2018-	DASHBMW006
F750/850 GS	2018-	DASHBMW007
R1200 GS	2017-	DASHBMW008

MODELLO	ANNI	CODICE
R1250 R/R/S	2019-	DASHBMW009
S1000RR	2019-	DASHBMW010
F700GS	2011-2017	DASHBMW011
F800 GS/GT/R/S/ST	2006-2018	DASHBMW012
G310R/GS	2017-	DASHBMW013
R1200GS/ADVENTURE	2013-	DASHBMW014
R nineT / RACER	2017-	DASHBMW015
R nineT / SCRAMBLER	2017-2020	DASHBMW016
R nineT / PURE	2017-2020	DASHBMW017
R nineT / URBAN	2017-2020	DASHBMW018
R1200RT	2014-2018	DASHBMW019
R1250RT	2019-2020	DASHBMW020
S1000XR	2020-	DASHBMW021
F900R / XR	2020-	DASHBMW022
F750/850 GS - (Connectivity)	2018-	DASHBMW023
R1250 GS - (Connectivity)	2018-	DASHBMW024
M 1000RR	2021-	DASHBMW025
S 1000R	2021-	DASHBMW027
R125 RT	2021-	DASHBMW026
DUCATI		
MONSTER 796/797/821/937/1200	2014-	DASHDUC001
SUPERSPORT (S)	2017-	DASHDUC002
HYPERMOTARD 950	2019-	DASHDUC003
HYPERMOTARD 796/821/939/1100	2006-2018	DASHDUC004

MODELLO	ANNI	CODICE
HYPERSTRADA 821/939	2012-2016	DASHDUC005
STREETFIGHTER 848/1100	2008-2015	DASHDUC006
899/959/1199/1299 Panigale	2013-	DASHDUC007
V4/V4 S Panigale	2018-	DASHDUC008
V4 R Panigale	2019-	DASHDUC009
MULTISTRADA 1200/S	2010-2014	DASHDUC010
DIAVEL	2011-2018	DASHDUC011
MULTISTRADA 950/1200/1260	2015-	DASHDUC012
SCRAMBLER 1100 (TRIBUTE PRO)	2018-	DASHDUC013
SCRAMBLER 400/800	2015-	DASHDUC014
DIAVEL 1260	2019-	DASHDUC015
XDIAVEL	2016-	DASHDUC016
PANIGALE V2	2020-	DASHDUC017
STREETFIGHTER V4	2020-	DASHDUC018
MULTISTRADA V4	2021-	DASHDUC020
MULTISTRADA V4 S	2021-	DASHDUC019
MULTISTRADA V2	2021-	DASHDUC021
URBAN MOTORAD	2022	DASHDUC022
MULTISTRADA V4 PIKES PEAK	2021-	DASHDUC023
STREETFIGHTER V2	2021-	DASHDUC024
STREETFIGHTER V4 SP	2022-	DASHDUC025
HONDA		
CB650R/F	2015-2018	DASHHON001
CBR650R/F	2015-2018	DASHHON002
CBR1000RR FIREBLADE/SP	2012-2016	DASHHON003
VFR800	2015-	DASHHON004
CBR300RR	2015-2017	DASHHON005
CBR1000RR FIREBLADE/SP	2017-2019	DASHHON006
CB650R/F	2019-2021	DASHHON007
CBR650R/F	2019-	DASHHON008
CB500F/X	2019-	DASHHON009
CBR500R	2019-	DASHHON010
CB1000R / +NEO SPORTS CAFE	2018-2020	DASHHON011
CB1100EX	2014-	DASHHON012
CB1100RS	2017-	DASHHON013
CBR500R/F/X	2013-	DASHHON014
CRF250L/RALLY	2017-	DASHHON015
MSX125 GROM	2014-2020	DASHHON016
CBR600RR	2007-2019	DASHHON017
CRF1000L AFRICA TWIN	2018-2019	DASHHON018
AFRICA TWIN ADVENTURE SPORT	2018-2019	DASHHON019
MONKEY	2018-	DASHHON020
SUPER CUB	2018-	DASHHON021
VFR800X CROSSRUNNER	2014-	DASHHON022
VRF1200X	2012-	DASHHON023
CB1100S	2013-2016	DASHHON024
CBR1000RR	2020-	DASHHON025

MODELLO	ANNI	CODICE
AFRICAN TWIN	2020-	DASHHON026
AFRICAN TWIN ADVENTURE SPORT	2020-	DASHHON027
GOLDWING	2020-	DASHHON028
BAGGER	2020	DASHHON029
NC750X	2016-2020	DASHHON030
AFRICAN TWIN	2015-2017	DASHHON031
X-ADV	2017-2020	DASHHON032
CMX Rebel 500	2017-2020	DASHHON033
CB300R	2018-	DASHHON034
CB125R	2018-	DASHHON035
NSF250R	2012-	DASHHON036
X-ADV	2021	DASHHON037
CB1000R	2021-	DASHHON038
CMX500 REBEL	2020-	DASHHON039
CMX1100 REBEL	2021	DASHHON040
NC750X	2021-	DASHHON041
MSX125	2021-	DASHHON042
NT1100	2022-	DASHHON043
HUSQVARNA		
NORDEN 901	2022	DASHHUS001
KAWASAKI		
NINJA 250	2018-	DASHKAW001
NINJA 400	2018-	DASHKAW002
NINJA 650	2017-	DASHKAW003
NINJA 1000	2017-	DASHKAW004
Z1000SX	2018-	DASHKAW005
VERSYS X-300	2017-	DASHKAW006
ZX6R	2019-	DASHKAW007
VERSYS 650	2015-2021	DASHKAW008
VERSYS 1000	2015-2018	DASHKAW009
VERSYS 1000	2019-	DASHKAW010
H2 H2R	2015-	DASHKAW011
Z400	2019-	DASHKAW012
Z650	2017-	DASHKAW013
Z900	2017-	DASHKAW014
Z800	2012-	DASHKAW015
Z900RS/CAFÉ	2017-	DASHKAW016
Z1000	2015-	DASHKAW017
ZX10R	2011-	DASHKAW018
ZZR1400	2012-	DASHKAW019
ZX6R	2009-2018	DASHKAW020
Z1000SX	2011-2016	DASHKAW021
VULCAN S	2015-	DASHKAW022
VERSYS 1000 (SE)	2019-	DASHKAW023
H2 SX (SE)	2018-	DASHKAW024
GTR1400	2007-	DASHKAW025
ER6F	2012-	DASHKAW027
ZH2	2020-	DASHKAW028
NINJA 1000SX	2020-	DASHKAW029

MODELLO	ANNI	CODICE
Z900	2020-	DASHKAW030
NINJA 650	2020-	DASHKAW031
Z650	2020-	DASHKAW032
Ninja ZX-10R/RR	2021	DASHKAW033
Z650RS	2021-	DASHKAW034
VERSYS 650	2022	DASHKAW035
KTM		
125/390 DUKE	2011-2016	DASHKTM001
RC125/200/390	2013-2020	DASHKTM002
1290 SUPERDUKE	2013-2016	DASHKTM003
1290 SUPERDUKE GT	2016-2018	DASHKTM004
SUPER ADVENTURE	2015-2017	DASHKTM005
1050/1090/1190 ADVENTURE	2013-2020	DASHKTM006
1290 SUPER ADVENTURE S	2021-	DASHKTM007
890 DUKE/R	2021-	DASHKTM008
125 DUKE	2021-	DASHKTM009
390 ADVENTURE	2020-	DASHKTM010
890 ADVENTURE	2021-	DASHKTM011
RC 125 RC 390	2021-	DASHKTM014
1290 SUPER DUKE R	2021-	DASHKTM012
1290 SUPER DUKE GT	2021	DASHKTM013
1290 SUPERDUKE GT	2022-	DASHKTM015
MV AGUSTA		
TURISMO VELOCE	2021	DASHMVA001
BRUTALE 1000	2021	DASHMVA002
BRUTALE 800	2021	DASHMVA003
RUSH 1000	2021	DASHMVA004
DRAGSTER 800	2021	DASHMVA005
SUPERVELOCE	2021	DASHMVA006
F3	2021	DASHMVA007
SUZUKI		
GSX-S750	2017-	DASHSUZ001
GSX-S1000	2016-2020	DASHSUZ002
SV650	2016-	DASHSUZ003
GSX-R1000	2009-2016	DASHSUZ004
GSX-R1000	2017-	DASHSUZ005
KATANA	2019-	DASHSUZ006
GSX-S1000 GSX-S950	2021-	DASHSUZ009
HAYABUSA	2021-	DASHSUZ007
V-STROM 1050	2021-	DASHSUZ008
TRIUMPH		
STREET TRIPLE	2013-	DASHTRI001
STREET TRIPLE S	2017-	DASHTRI002
SPEED TRIPLE	2011-2016	DASHTRI003
DAYTONA 675	2011-2020	DASHTRI004
STREET TRIPLE R/RS	2017-	DASHTRI005
SPEED TRIPLE R/RS	2018-2020	DASHTRI006
TIGER 800/1200	2018-	DASHTRI007
TIGER 800/1200 EXPLORER	2012-2016	DASHTRI008

MODELLO	ANNI	CODICE
TIGER 850 SPORT	2021	DASHTRI009
10500 TIGER SPORT	2013-	DASHTRI015
ROCKET 3	2020-	DASHTRI010
SCRAMBLER 1200	2019-	DASHTRI011
TIGER 900	2020-	DASHTRI012
SPEED TRIPLE 1200 RS	2021-	DASHTRI013
TRIDENT 660	2021-	DASHTRI014
SPEED TRIPLE 1200 RR	2022-	DASHTRI016
YAMAHA		
YZF-R1	2015-	DASHYAM002
YZF-R1M	2015-	DASHYAM003
MT-10SP	2016-	DASHYAM004
900 TRACER GT	2018-	DASHYAM005
MT-03	2006-	DASHYAM006
R25/R3	2015-2018	DASHYAM007
R25/R3	2019-	DASHYAM008
MT-07	2014-2020	DASHYAM009
FZ-07	2014-	DASHYAM010
TRACER 700	2014-2020	DASHYAM011
MT-09/TRACER 900 /FJ-09	2013-	DASHYAM012
FZ-09	2013-	DASHYAM013
XT1200Z SUPER TENERE	2013-	DASHYAM014
YZF-R6	2017-	DASHYAM015
YZF-R1	2009-2014	DASHYAM016
MT-125	2014-2019	DASHYAM017
YZF-R125	2019-	DASHYAM018
MT-10	2016-2021	DASHYAM019
FZ-10	2016-	DASHYAM020
NIKEN	2018-	DASHYAM021
MT/FZ-09	2013-2020	DASHYAM022
YZF-R6	2008-2016	DASHYAM023
YZF-R125	2014-2018	DASHYAM024
MT-125	2020-	DASHYAM025
TRACER 7	2021-	DASHYAM027
MT-03	2020-	DASHYAM026
MT-07	2021-	DASHYAM028
TRACER 9 / GT	2021-	DASHYAM029
MT-09	2021-	DASHYAM030
R7	2021-	DASHYAM031
MT-10	2022-	DASHYAM032
XSR125	2021-	DASHYAM033

FKWISORS



FK VISORS
THE VISORS SPECIALISTS



PRODUZIONE DI VISIERE MADE IN ITALY

Da Forbikes Srl nasce FK Visors, un brand completamente dedicato alla produzione di visiere per caschi ed altre applicazioni.

Siamo una delle principali realtà nella produzione di visiere e siamo a disposizione delle aziende produttrici di caschi di qualsiasi tipo e settore, sia per la produzione finale della visiera che per lo studio e la realizzazione dei modelli. Ad oggi, vantiamo un'**esperienza trentennale** nella produzione di visiere, Tear-off, visierini antifog e molto altro.

Grazie al prezioso apporto di Armando Bigliardi, tecnico professionista nella realizzazione di nuovi modelli di visiere e prototipi, collaboriamo con i maggiori produttori caschi di **diversi settori** come auto, moto, sci, ciclo, volo, fino a spaziare nei settori militare, medicale e odontoiatrico.

Ci occupiamo di tutte le fasi di progettazione della visiera utilizzando le migliori tecnologie. A questo uniamo la componente artigianale. Ogni visiera FK Visors è rifinita e controllata individualmente da tecnici qualificati per assicurare la massima qualità e purezza ottica. Garanzia dell'ottima qualità di produzione e controllo, la **termoformatura** garantisce ottimi risultati anche e soprattutto per piccole quantità, a discapito dello stampaggio ad iniezione che è preferibile per grandi lotti produttivi.

VISITA WWW.FKVISORS.IT PER MAGGIORI DETTAGLI



VISIERE ANTIGRAFFIO TRE BOTTONI (INTERASSE REGOLABILE) PER CASCO JET - BOTTONI INCLUSI

70-0010TR	Trasparente
70-0010OR	Arancio
70-0010FC	Fumè chiaro
70-0010FS	Fumè scuro
70-0010MA	Marrone

70-0010TR



70-0010OR



70-0010FC



70-0010FS



70-0010MA



VISIERE COMPATIBILE CON CASCHI ARAI® GP-5, SK-5

70-0090	Trasparente
70-0091	Fumè scuro
70-0093	Specchiata blu 61%
70-0094	Specchiata rosso RED68

70-0090



70-0091



70-0093



70-0094



Trattamento antigraffio
Policarbonato di spessore 3 mm



Aggiornamenti sul sito www.forbikes.it

È vietato l'utilizzo su strada pubblica degli articoli non omologati.

VISIERE COMPATIBILI CON CASCHI ARAI® GP-6, GP-6 RC, GP-6K, GP-6S, SK-6

70-0040	Trasparente
70-00400	Trasparente con inserto antifog/rain trasparente
70-00405	Trasparente con inserto antifog/rain giallo
70-00407	Trasparente con inserto antifog/rain arancio
70-004180	Fumè scuro
70-004170	Fumè marrone
70-004150	Fumè chiaro
70-0042	Specchiata argento super strong
70-0043	Specchiata blu 61%
70-0044RED68	Specchiata rosso RED68
70-0045	Specchiata gold M04
70-0046	Specchiata light violet
70-0047	Arancio
70-0048	Specchiata verde green 50

70-0040



70-00400



70-00405



70-00407



70-004180



70-004170



70-004150



70-0042



70-0043



70-0044RED68



70-0045



70-0046



70-0047



70-0048

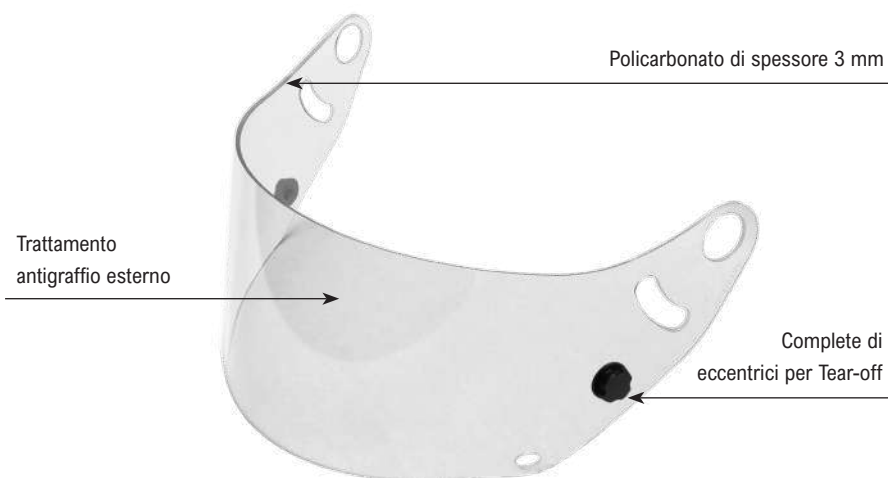

Specchiatura
FK WATER REPELLENT



Specchiatura con trattamento FK WATER REPELLENT in grado di far scorrere l'acqua sulla superficie della visiera, garantendo massima visibilità e comfort anche nelle giornate di pioggia.

VISIERE COMPATIBILI CON CASCHI ARAI® CK-6

70-0050	Trasparente
70-00500	Trasparente con inserto antifog/rain trasparente
70-00505	Trasparente con inserto antifog/rain giallo
70-00507	Trasparente con inserto antifog/rain arancio
70-005180	Fumè scuro
70-005170	Fumè marrone
70-005150	Fumè chiaro
70-0052	Specchiata argento super strong
70-0053	Specchiata blu 61%
70-0054RED68	Specchiata rosso RED68
70-0055	Specchiata gold M04
70-0056	Specchiata light violet
70-0057	Arancio
70-0058	Specchiata verde green 50

70-0050



70-00500



70-00505



70-00507



70-005180



70-005170



70-005150



70-0052



70-0053



70-0054RED68



70-0055



70-0056



70-0057



70-0058

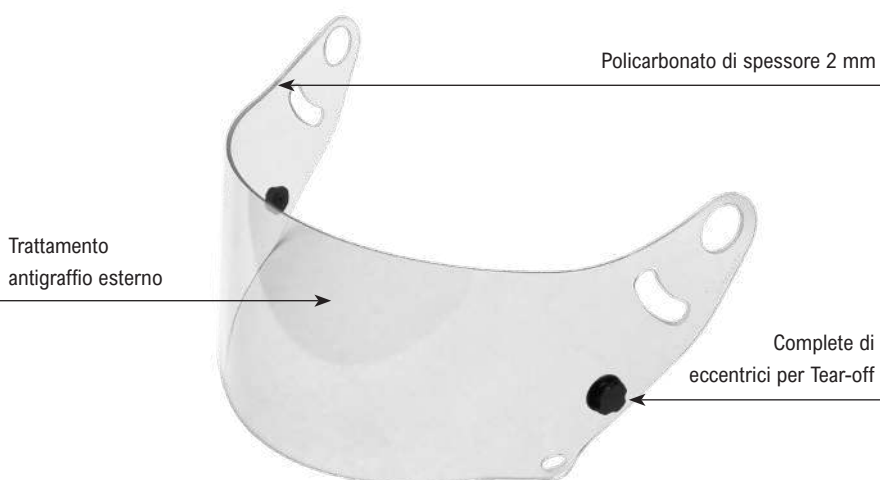

Specchiatura FK WATER REPELLENT



Specchiatura con trattamento FK WATER REPELLENT in grado di far scorrere l'acqua sulla superficie della visiera, garantendo massima visibilità e comfort anche nelle giornate di pioggia.

VISIERE COMPATIBILI CON CASCHI ARAI® GP-7

70-0150	Trasparente
70-01500	Trasparente con inserto antifog/rain trasparente
70-01505	Trasparente con inserto antifog/rain giallo
70-01507	Trasparente con inserto antifog/rain arancio
70-015180	Fumè scuro
70-015170	Fumè marrone
70-015150	Fumè chiaro
70-0152	Specchiata argento super strong
70-0153	Specchiata blu 61%
70-0154	Specchiata rosso RED68
70-0155	Specchiata gold M04
70-0156	Specchiata light violet
70-0157	Arancio
70-0158	Specchiata verde green 50

70-0150



70-01500



70-01505



70-01507



70-015180



70-015170



70-015150



70-0152



70-0153



70-0154



70-0155



70-0156



70-0157



70-0158

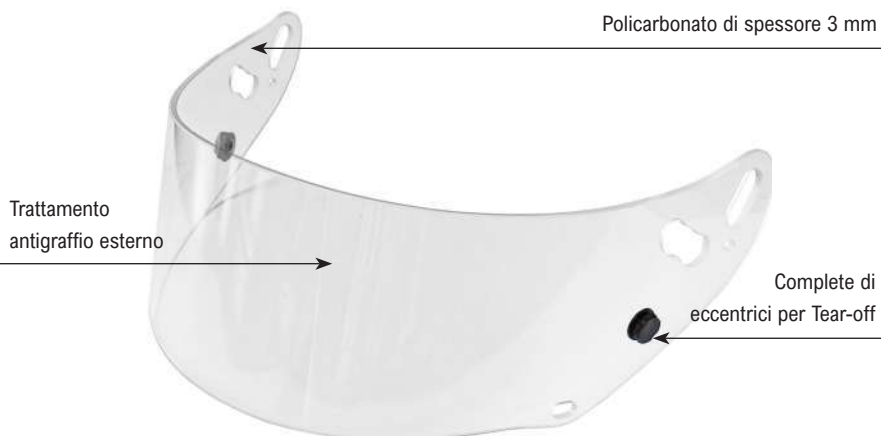

Specchiatura FK WATER REPELLENT



Specchiatura con trattamento FK WATER REPELLENT in grado di far scorrere l'acqua sulla superficie della visiera, garantendo massima visibilità e comfort anche nelle giornate di pioggia.

VISIERE COMPATIBILI CON CASCHI MOMO DESIGN®

70-0060	Trasparente
70-006180	Fumè scuro
70-0062	Specchiata argento
70-0063	Specchiata blu
70-0064	Specchiata rosso
70-0065	Specchiata oro
70-0066	Specchiata rosa
70-0068	Specchiata verde

70-0060



70-006180



Trattamento antigraffio
Policarbonato di spessore 1,5 mm



70-0062



70-0063



70-0064



70-0065



70-0066



70-0068



FK CLEANERV – LIQUIDO PULIZIA VISIERA

70-0110 100 ml



La visiera è la parte più delicata di un casco. Per questo motivo è necessaria un'attenzione particolare durante la manutenzione.

FK cleanerV è stato progettato per garantire durata nel tempo della visiera e preservare la massima purezza ottica.

La nostra speciale formula è stata appositamente creata ed utilizzata a lungo dai nostri tecnici qualificati ed ora è disponibile per la vendita. Sicuro da usare su tutti i trattamenti, anche Anti-Fog che necessita di cure particolari durante la pulizia.

UFI: 0KXH-101G-1207-7X8A



Aggiornamenti sul sito www.forbikes.it

È vietato l'utilizzo su strada pubblica degli articoli non omologati.



VISIERE VINTAGE BUBBLE TRE BOTTONI

70-0070 Trasparente

70-00710 Marrone/trasparente

70-007150 Fumè chiaro

70-007180 Fumè scuro

70-00720 Specchiata argento

70-00728 Specchiata multicolor

70-0073 Blu/trasparente

70-0075 Giallo

70-0076 Rosa/trasparente

70-0077 Arancio

70-00770 Arancio/trasparente

70-0070



70-00710



70-007150



Made in Taiwan

70-007180



70-00720



70-00728



70-0073



70-0075



70-0076



70-0077



70-00770



FRONTINI ALZA-VISIERA TRE BOTTONI, APRIBILI

70-0080 Trasparente

70-0081 Nero

70-0080



70-0081



Meccanismo per rendere basculante la visiera a 3 bottoni fissa
Completo di bottoni di collegamento ed estremamente leggero

VISIERINO DI PROTEZIONE IN POLICARBONATO A2-TYPE

70-0100KITCE Kit montatura ad occhiale riutilizzabile + 1 visierino (certificato CE)

70-0100 Visierino a ricambio



CERTIFICATO CE

Lo schermo facciale "A2-Type" è certificato CE secondo la norma EN 166:2001
Registrazione numero: DPI/PPE331AT1966

Altezza 216 mm, larghezza 322 mm
Realizzato in Policarbonato 380 Micron
Copre interamente il volto e protegge viso e occhi da schizzi e goccioline
Dotato di una montatura ad occhiale e di una fascetta girotesta removibile, che lo rendono confortevole anche a seguito di un utilizzo prolungato



VISIERINO DI PROTEZIONE IN POLICARBONATO B-TYPE

70-0101KITCE Kit montatura ad archetto riutilizzabile + 1 visierino (certificato CE)

70-0101 Visierino a ricambio

Altezza 22 cm
Larghezza 36 cm



DPI certificato CE

Policarbonato 500 Micron

Lo schermo facciale "B-Type" è certificato CE. Registrazione numero: DPI/0497/2163
Realizzato in Policarbonato 500 Micron che garantisce massima resistenza nel tempo e purezza ottica, rispetto a materiali come PETG e PET



CERTIFICATO CE







TUBI FRENO IN TRECCIA DI ALTA QUALITÀ

HEL Performance è un'azienda inglese specializzata nella realizzazione di tubi freno e frizione in treccia ad alta performance.

Prima azienda al mondo ad applicare un **rivestimento in PVC** alla guaina per proteggere il tubo, rendendolo estremamente resistente e disponibile in tante colorazioni differenti, da sempre HEL Performance si propone di realizzare esclusivamente prodotti di altissima qualità, utilizzando unicamente leghe e metalli raffinati quali il titanio e l'acciaio Inox, garantendo un **prodotto di qualità superiore** per durata e prestazioni.

In virtù della stretta collaborazione iniziata nel 2017 tra Forbikes Srl e HEL Performance, Forbikes può oggi offrire tempistiche di preparazione e consegna dei kit particolarmente celeri e la possibilità di realizzare kit **tubi personalizzati**. I tubi su misura vengono realizzati direttamente da Forbikes, nello stabilimento di Reggio Emilia, seguendo le indicazioni fornite dal cliente riguardo la lunghezza delle varie linee freno e la loro quantità. L'utente finale potrà scegliere e personalizzare anche il tipo di raccordo e la bulloneria, ottenendo dei tubi freno completamente su misura e in grado di coniugare affidabilità ed alte prestazioni. Richiedere la modulistica via mail a commerciale@forbikes.it.

Tra le ultime novità del brand inglese, disponibili le pinze freno anteriori radiali, le pinze freno posteriori assiali, le pompe pollice e le pompe indice.



BULLONE ACCIAIO INOX PER RACCORDO SINGOLO

H16031C M10 x 1.00

H16032C M10 x 1.25



BULLONE ACCIAIO INOX PER RACCORDO DOPPIO

H16131C M10 x 1.00

H16132C M10 x 1.25



ADATTATORE PER POMPA FRENO RADIALE/ASSIALE

CFA-1



Adattatore di trasformazione da kit assiale a kit radiale, mantenendo i tubi assiali

BOCCOLA ACCIAIO INOX M10 PER CHIUSURA IMPIANTI ABS

SPACER



VITE SPURGO ACCIAIO INOX PER PINZE

BNM7X100 M7 x 1

BNM8X125 M8 x 1.25

BNM10X100 M10 x 1



BULLONE ACCIAIO INOX TUBO FRENO SINGOLO CON VITE SPURGO

H160-31BNC M10 x 1

H160-32BNC M10 x 1.25



BULLONE ACCIAIO INOX TUBO FRENO DOPPIO CON VITE SPURGO

H161-31BNC M10 x 1

H161-32BNC M10 x 1.25



FASCETTA STRINGITUBO CON GOMMA

HPC Diametro 9 mm



GOMMINO PASSACAVO

GROMMET Diametro 9 mm



KIT 10 PEZZI RONDELLA IN RAME

CCW-10 Diametro 10 mm



STÄUBLI

STAUBLIMALE Maschio

STAUBLIFEMAL Femmina

NEW



POMPA FRENO CNC 19 MM X 19 MM

HMC19MMBK Colore nero

HMC19MMGR Colore grigio

NEW

POMPA FRIZIONE CNC 16 MM X 16 MM

HMC16MMBK Colore nero

HMC16MMGR Colore grigio

NEW



Completamente CNC e realizzate in alluminio 6082-T6

La loro caratteristica peculiare è la possibilità di variare l'interasse tra fulcro e pompante, tramite la sostituzione di un inserto, e avere un'interasse alternativa di +1 o -1 mm



NEW**COPPIA PINZE ANTERIORI RADIALI**

HC1003232BK	100 mm, colore nero
HC1003232GR	100 mm, colore grigio
HC1083232BK	108 mm, colore nero
HC1083232GR	108 mm, colore grigio



Realizzate in alluminio Billet 6082-T6, l'integrità strutturale e la rigidità sono completamente ottimizzate
 Peso (senza pastiglie): 764 g

NEW**PINZA POSTERIORE ASSIALE 84 MM**

HC843232BK	Colore nero
HC843232NI	Colore nichel
HC843232CE	Colore cerakote



Caratterizzate da un interasse di fissaggio di 84 mm e da due pistoni in acciaio inossidabile alleggeriti per dissipare meglio il calore
 Peso (senza pastiglie e perno): 505 g



Aggiornamenti sul sito www.forbikes.it

È vietato l'utilizzo su strada pubblica degli articoli non omologati.



POMPA POLLICE

NEW

HTBBK	Colore nero
HTBGR	Colore grigio

Collare da acquistare separatamente

COLLARE FORCELLA PER POMPA POLLICE

NEW

HTBBB38BK	38 mm	HTBBB47BK	47 mm
HTBBB39BK	39 mm	HTBBB48BK	48 mm
HTBBB40BK	40 mm	HTBBB49BK	49 mm
HTBBB41BK	41 mm	HTBBB50BK	50 mm
HTBBB42BK	42 mm	HTBBB51BK	51 mm
HTBBB43BK	43 mm	HTBBB52BK	52 mm
HTBBB44BK	44 mm	HTBBB53BK	53 mm
HTBBB45BK	45 mm	HTBBB54BK	54 mm
HTBBB46BK	46 mm	HTBBB55BK	55 mm



POMPA INDICE

NEW

HFBBK10MM	10 mm
HFBBK11MM	11 mm
HFBBK13MM	13 mm



Completamente CNC e realizzate in alluminio Billet 6082-T6

APPLICATIVI TUBI FRENO

LEGENDA CODICI:

HBK = KIT COMPLETO
(linee anteriori + linea posteriore)
numero tubi superiore a 1

HBF = SOLO LINEA ANTERIORE

HBR = SOLO LINEA POSTERIORE

HBC = SOLO LINEA FRIZIONE

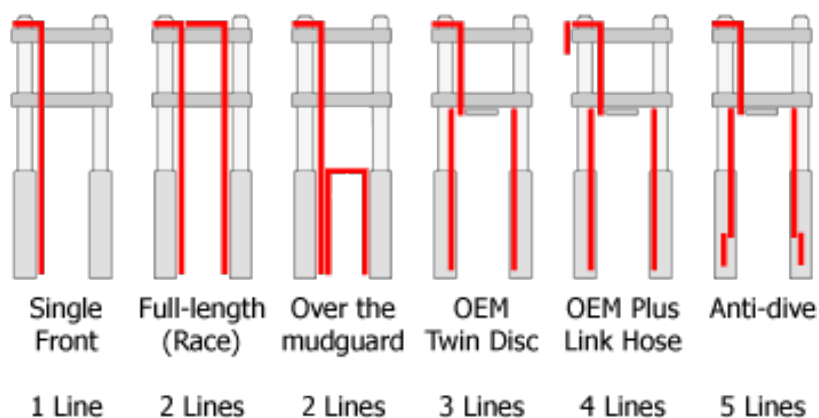

COLORI RIVESTIMENTO (A SCELTA):

Nero
Carbon-look
Trasparente
Bianco
Giallo
Arancione
Rosso
Verde Kawasaki
Blu

CILIND.	MODELLO	ANNI	CODICE	CONFIGURAZIONE	ANT. SUP.	ANT. INF.	AGG. POST.	FRIZ.	TOT. TUBI
AJP									
650	PR7 650 Adventure	2019-2020	HBK0883	Set Up OEM anteriore	1		1		2
APRILIA									
50	50 SX Motard	2008-2010	HBK0086	Set Up OEM anteriore	1		1		2
50	RS50	1993-1998	HBK0025	Set Up OEM anteriore	1		1		2
50	RS50	1999-2006	HBK0024	Set Up OEM anteriore	1		1		2
50	RS50	2004-2010	HBK0085	Set Up OEM anteriore	1		1		2
50	RX50	1999-2007	HBK0058	Set Up OEM anteriore	1		1		2
50	SR50	1999-2006	HBK0068	Set Up OEM anteriore	1		1		2
125	125 Red Rose Custom	1988-1994	HBK0080	Set Up OEM anteriore	1		1		2
125	AF1 125 Sintesi	1986-1992	HBK0090	Set Up OEM anteriore	1		1		2
125	MX125	2006-2008	HBK0084	Set Up OEM anteriore	1		1		2
125	Pegaso 125	1992-1995	HBK0001	Set Up OEM anteriore	1		1		2
125	RS125	1999-2005	HBK0006	Set Up OEM anteriore	1		1		2
125	RS125	2006-2010	HBK0087	Set Up OEM anteriore	1		1		2
125	RS125 AF1-125	1991-1993	HBK0005	Set Up OEM anteriore	1		1		2
125	RS125 Extrema	1993-1998	HBK0012	Set Up OEM anteriore	1		1		2
125	Tuono 125	2001-2004	HBF0072	Set Up RACE	1				1

CILIND.	MODELLO	ANNI	CODICE	CONFIGURAZIONE	ANT. SUP.	ANT. INF.	AGG.	POST.	FRIZ.	TOT. TUBI
125	SR125	2000-2003	HBK0096	Set Up OEM anteriore	1					1
125	SX125	2008-2011	HBK0097	Set Up OEM anteriore	1			1		2
250	RS250	1994-1997	HBK0015	Set Up RACE / OEM anteriore	1	1		1		3
250	RS250	1994-1997	HBK0014	Set Up OEM anteriore	1	2		1		4
250	RS250	1998-2004	HBK0073	Set Up RACE	1	1		1		3
250	RS250	1998-2004	HBK0023	Set Up OEM anteriore	1	1	1	1		4
450	SXV450 / SXV550 Super Moto	2005-2007	HBK0074	Set Up RACE	1			1		2
650	Moto 6.5	1995-1997	HBK0069	Set Up OEM anteriore	1			1		2
650	Pegaso 650	1995-1996	HBK0083	Set Up OEM anteriore	1			1		2
650	Pegaso 650 Rotax	1999-2005	HBK0075	Set Up OEM anteriore	1			1		2
650	Pegaso 650 Strada	2006-2010	HBK0076	Set Up OEM anteriore	1			1		2
650	Pegaso 650 Trail	2005-2009	HBK0063	Set Up OEM anteriore	1			1		2
750	Shiver SL750	2009-2011	HBK0017	Set Up RACE	1	1		1		3
750	Shiver SL750	2009-2011	HBK0016	Set Up OEM anteriore	1	1	1	1		4
1000	ETV1000 Caponord	2001-2003	HBK0081	Linea frizione					1	1
1000	ETV1000 Caponord	2001-2003	HBK0082	Set Up RACE	1	1		1		3
1000	ETV1000 Caponord	2001-2004	HBK0081	Set Up OEM anteriore	1	1	1	1		4
1000	Futura RST 1000	2001-2004	HBC0070	Linea frizione					1	1
1000	Futura RST 1000	2001-2004	HBK0071	Set Up RACE	1	1		1		3
1000	Futura RST 1000	2001-2004	HBK0070	Set Up OEM anteriore	1	1	1	1		4
1000	RSV Mille 1000	1998-2000	HBK0033	Set Up RACE	1	1		1		3
1000	RSV Mille 1000	1998-2000	HBK0032	Set Up OEM anteriore	1	1	1	1		4
1000	RSV Mille 1000	2001-2005	HBK0056	Set Up RACE	1	1		1		3
1000	RSV Mille 1000	2001-2005	HBK0057	Set Up OEM anteriore	1	1	1	1		4
1000	RSV Mille 1000	2005-2010	HBK0079	Set Up RACE	1	1		1		3
1000	RSV Mille 1000	2005-2010	HBK0078	Set Up OEM anteriore	1	1	1	1		4
1000	RSV4	2008-2010	HBK0089	Set Up RACE	1	1		1		3
1000	RSV4	2008-2010	HBK0088	Set Up OEM anteriore	1	1	2	1		5
1000	RSV-R Mille 1000	1999-2000	HBK0039	Set Up RACE	1	1		1		3
1000	RSV-R Mille 1000	1999-2000	HBK0038	Set Up OEM anteriore	1	1	1	1		4
1000	RSV-R Mille 1000	2001-2005	HBK0064	Set Up RACE	1	1		1		3
1000	RSV-R Mille 1000	2001-2005	HBK0065	Set Up OEM anteriore	1	1	1	1		4
1000	RSV-SP Mille 1000	1999-2000	HBK0043	Set Up RACE	1	1		1		3
1000	RSV-SP Mille 1000	1999-2000	HBK0042	Set Up OEM anteriore	1	1	1	1		4
1000	SL1000 Falco	1999-2005	HBK0047	Set Up RACE	1	1		1		3
1000	SL1000 Falco	1999-2005	HBK0046	Set Up OEM anteriore	1	1	1	1		4
1000	Tuono 1000	2002-2005	HBC0066	Linea frizione					1	1
1000	Tuono 1000	2002-2005	HBK0067	Set Up RACE	1	1		1		3
1000	Tuono 1000	2002	HBK0066	Set Up OEM anteriore	1	1	1	1		4
1000	Tuono 1000	2006-2010	HBC0092	Linea frizione					1	1
1000	Tuono 1000	2006-2010	HBK0092	Set Up RACE	1	1		1		3
1000	Tuono 1000	2006-2010	HBK0093	Set Up OEM anteriore	1	1	1			3
1000	Tuono 1000 Factory R	2007-2009	HBK0091	Set Up RACE	1	1				2
1000	Tuono 1000 V4 APRC	2011-2013	HBK0094	Set Up OEM anteriore	1	1		1		3
1000	Tuono 1000 V4 APRC	2011-2013	HBK0095	Set Up RACE	1	1		1		3
1000	RSV 1000 Mille	1999-2002	HBC0032	Linea frizione					1	1
1000	RSV 1000 Mille	2004-2007	HBC0078	Linea frizione					1	1
1000	SL1000 Falco	1999-2005	HBC0046	Linea frizione					1	1

CILIND.	MODELLO	ANNI	CODICE	CONFIGURAZIONE	ANT. SUP.	ANT. INF.	AGG.	POST.	FRIZ.	TOT. TUBI
BENELLI										
125	Adiva 125	2000-2003	HBK0101	Set Up OEM anteriore	1					1
354	354 Sport	1979	HBK0110	Set Up OEM anteriore	1	1	1	1		4
504	504 Sport	1979-1981	HBK0100	Set Up OEM anteriore	1	1	1	1		4
750	750 Sei	1972-1978	HBK0104	Set Up OEM anteriore	1	2				3
900	900 Sei	1979-1989	HBK0109	Set Up OEM anteriore	1	2	1	1		5
900	Tornado RS pinze BREMBO	2003-2011	HBK0108	Set Up RACE	1	1		1		3
900	Tornado RS pinze BREMBO	2003-2011	HBK0107	Set Up OEM anteriore	1	1	1	1		4
900	Tornado TRE / LE	2003-2006	HBK0106	Set Up RACE	1	1		1		3
900	Tornado TRE / LE	2003-2006	HBK0105	Set Up OEM anteriore	1	1	1	1		4
1130	TnT	2004-2006	HBK0103	Set Up RACE	1	1		1		3
1130	TnT	2004-2006	HBK0102	Set Up OEM anteriore	1	1	1	1		4
BETA										
250	Evo 250	2009-2011	HBK0201	Set Up OEM anteriore	1					1
	Moto Cross	1998-2000	HBK0200	Set Up OEM anteriore	1			1		2
	Moto Cross	1999-2000	HBC0201	Linea frizione					1	1
BIMOTA										
1000	KB1	1977-1979	HBK0300	Set Up OEM anteriore	1	2		1		4
1000	YB8	1990-1994	HBK0302	Set Up OEM anteriore	1	1	1	1		4
1000	YB8	1990-1994	HBC0302	Linea frizione					1	1
1098	SB6	1991-1999	HBK0301	Set Up OEM anteriore	1	2		1		4
BMW										
1000	S1000RR	2010-2013	HBK0618	Set Up RACE	1	1		1		3
1000	S1000RR	2010-2013	HBK0616	Set Up OEM anteriore	1	1	1	1		4
1000	S1000RR	2019-2020	HBFKK0026	Set Up RACE						3
1000	S1000RR ABS	2010-2013	HBK0620	Set Up OEM anteriore	4			2		6
1000	S1000RR ABS	2014-2018	HBK0401	Set Up OEM anteriore	4			2		6
1000	S1000RR ABS	2019-2020	HBK0622	Set Up OEM anteriore	4			2		6
1000	S1000RR ABS HP4	2012-2014	HBK0621	Set Up OEM anteriore	4			2		6
1000	S1000R ABS	2014-2016	HBK0403	Set Up OEM anteriore	4			2		6
1100	R1100 RS ABS	1993-2002	HBK0619	Set Up OEM anteriore	1	2	1	1		5
1100	R1100S	1998-2006	HBFKK0004	Set Up OEM anteriore	1	2		1		4
1200	R1200 GS Adventurer	2009	HBC0411	Linea frizione					1	1
1200	R1200C	1997-2004	HBK0613	Set Up OEM anteriore	1	1	1	1		4
BOMBARDIER										
650	Quad : DS650	2000-2003	HBK0650	Set Up OEM anteriore	1	1		1		3
BUELL										
1000	XB9SX	2004-2009	HBK0713	Set Up OEM anteriore	1			1		2
1125	CR1125	2009-2011	HBC0714	Linea frizione					1	1
1125	CR1125	2009-2011	HBK0714	Set Up OEM anteriore	1			1		2
1200	M2 Cyclone	1997-1998	HBK0700	Set Up OEM anteriore	1			1		2
1200	S1 Lightning - linea posteriore non possibile	1997-1998	HBK0702	Set Up OEM anteriore	1		1	1		3
1200	S1 Lightning Strike	1997-1998	HBK0704	Set Up OEM anteriore	1			1		2
1200	S1 White Lightning	1997-1998	HBK0706	Set Up OEM anteriore	1		1	1		3
1200	X1 Lightening	1999-2001	HBK0708	Set Up OEM anteriore	1			1		2
1200	XB12R	2003-2007	HBK0712	Set Up OEM anteriore	1			1		2
1200	XB12S	2003-2007	HBK0711	Set Up OEM anteriore	1			1		2

CILIND.	MODELLO	ANNI	CODICE	CONFIGURAZIONE	ANT. SUP.	ANT. INF.	AGG.	POST.	FRIZ.	TOT. TUBI
1200	XB12SS	2010	HBF0715	Set Up OEM anteriore	1					1
BULTACO										
	Moto Cross	2000-2001	HBK0750	Set Up OEM anteriore	1			1		2
	Moto Cross	2000-2001	HBC0752	Linea frizione					1	1
CAGIVA										
50	Prima 50	1992-1995	HBK0827	Set Up OEM anteriore	1			1		2
125	Blues 125	1991-1993	HBK0844	Set Up OEM anteriore	1			1		2
125	Mito	1991-1999	HBK0838	Set Up OEM anteriore	1			1		2
125	Mito Evolution	2000-2001	HBK0837	Set Up OEM anteriore	1			1		2
125	Mito Mk1	1992-1999	HBK0818	Set Up OEM anteriore	1			1		2
125	Planet 125	1998-2006	HBK0843	Set Up OEM anteriore	1			1		2
125	Super City 125	1991-2006	HBK0842	Set Up OEM anteriore	1			1		2
250	250 Ala Blu Trail	1983-1984	HBF0800	Set Up OEM anteriore	1					1
500	Canyon 500 Trail	1998-2001	HBF0814	Set Up OEM anteriore	1					1
600	Canyon 600	1995-1997	HBK0845	Set Up OEM anteriore	1			1		2
650	650 Alazzurra	1985-1988	HBK0839	Set Up RACE	1	1		1		3
650	650 Alazzurra	1985-1988	HBK0802	Set Up OEM anteriore	1	2		1		4
650	650 Alazzurra	1985-1988	HBC0819	Linea frizione					1	1
650	Raptor	2000-2001	HBK0832	Set Up RACE	1	1		1		3
650	Raptor	2000-2001	HBK0831	Set Up OEM anteriore	1	1	1	1		4
750	750 Elefant	1994-1998	HBC0835	Linea frizione					1	1
750	750 Elefant	1994-1998	HBK0835	Set Up OEM anteriore	1			1		2
900	900 Elefant	1995-2000	HBK0840	Set Up RACE	1	1		1		3
900	900 Elefant	1995-2000	HBK0809	Set Up OEM anteriore	1	2		1		4
900	900 ie Elefant	1991-2000	HBC0818	Linea frizione					1	1
900	900 ie Elefant	1991-2000	HBK0819	Set Up OEM anteriore	1			1		2
900	Gran Canyon	1998-2000	HBK0836	Set Up OEM anteriore	1	1	1	1		4
CCM										
644	644 Dual Sport	2003-2005	HBK0881	Set Up OEM anteriore	1			1		2
650	R30	2003-2005	HBK0880	Set Up OEM anteriore	1			1		2
404	404E	2003-2004	HBK0882	Set Up OEM anteriore	1			1		2
DUCATI										
250	250 Desmo	1975	HBF0900	Set Up OEM anteriore	1					1
350	350 Desmo	1975	HBF0901	Set Up OEM anteriore	1					1
400	400 Monster	1994-2002	HBK1176	Linea frizione					1	1
400	400 Monster	1994-2002	HBK1176	Set Up OEM anteriore	1			1		2
400	400 SS Sports	1991-1993	HBF0902	Set Up OEM anteriore	1					1
500	500 Pantah (ALTERNATIVE)	1980-1982	HBK1096	Set Up OEM anteriore	1	2				3
500	500 SL Pantah	1980-1984	HBK0905	Set Up OEM anteriore	1	2		1		4
600	600 Monster	1994-2002	HBK1176	Linea frizione					1	1
600	600 Monster	1994-2002	HBK1043	Set Up OEM anteriore	1			1		2
600	600 Monster Dark	1998-2001	HBC1044	Linea frizione					1	1
600	600 Monster Dark	1998-2001	HBK1044	Set Up OEM anteriore	1			1		2
600	600 Pantah	1980-1985	HBC0910	Linea frizione					1	1
600	600 SL Pantah	1980-1984	HBK0910	Set Up OEM anteriore	1	2		1		4
600	600 SS	1993-2002	HBC1086	Linea frizione					1	1
600	600 SS	1994-1998	HBK1086	Set Up OEM anteriore	1			1		2
600	600 TL Pantah	1984-1985	HBK0915	Set Up OEM anteriore	1	2		1		4

CILIND.	MODELLO	ANNI	CODICE	CONFIGURAZIONE	ANT. SUP.	ANT. INF.	AGG.	POST.	FRIZ.	TOT. TUBI
620	620 Monster	1994-2002	HBC1176	Linea frizione					1	1
620	620 Monster	2003-2006	HBC1177	Set Up OEM anteriore	1			1		2
620	620 Sport	2003-2005	HBC1102	Set Up RACE	1	1		1		3
650	650 GT Pantah	1983-1986	HBC0917	Set Up OEM anteriore	1	2		1		4
650	Indiana 650	1986-1987	HBC1041	Set Up OEM anteriore	1			1		2
695	695 Monster	2007-2010	HBC1183	Linea frizione					1	1
695	695 Monster	2007-2010	HBC1182	Set Up RACE	1	1		1		3
695	695 Monster	2007-2010	HBC1196	Set Up sopra parafango anteriore	1	1		1		3
695	695 Monster	2007-2010	HBC1183	Set Up OEM anteriore	1	1	1	1		4
696	696 Monster	2010-2013	HBC1223	Set Up sopra parafango anteriore	1	1		1		3
748	748 Biposto / SPS	1999-2003	HBC0926	Set Up RACE	1	1		1		3
748	748 Biposto / Strada	1995-1998	HBC0919	Set Up RACE	1	1		1		3
748	748 Biposto / Strada	1995-1998	HBC0918	Set Up OEM anteriore	1	1	1	1		4
748	748R	1999-2002	HBC1171	Linea frizione					1	1
748	748R	1999-2002	HBC1171	Set Up RACE	1	1		1		3
749	749	2003-2005	HBC1100	Linea frizione					1	1
749	749	2003-2005	HBC1100	Set Up sopra parafango anteriore	1	1		1		3
749	749	2003-2005	HBC1170	Set Up OEM anteriore	1	1	1	1		4
750	750 F1 Mk II	1985-1988	HBC0951	Linea frizione					1	1
750	750 F1 Mk II	1985-1988	HBC0951	Set Up OEM anteriore	1	2		1		4
750	750 F1 Montjuic	1987-1988	HBC0955	Set Up OEM anteriore	1	2		1		4
750	750 Monster	1994-2002	HBC1176	Linea frizione					1	1
750	750 Monster	1994-2002	HBC1130	Set Up OEM anteriore	1			1		2
750	750 Paso	1986-1994	HBC0956	Linea frizione					1	1
750	750 Paso	1986-1994	HBC1172	Set Up RACE	1	1		1		3
750	750 Paso	1986-1994	HBC0956	Set Up OEM anteriore	1	2		1		4
750	750 Sport	1988-1990	HBC0961	Linea frizione					1	1
750	750 Sport	1988-1990	HBC0961	Set Up OEM anteriore	1	2		1		4
750	750 Sport	2003-2004	HBC1107	Set Up RACE	1	1		1		3
750	750 SS	1991-1993	HBC1166	Set Up OEM anteriore	1			1		2
750	750 SS	1993-2002	HBC1165	Linea frizione					1	1
750	750 SS	1994-1997	HBC1165	Set Up RACE	1	1		1		3
750	750 SS	1998-2002	HBC1144	Set Up RACE	1	1		1		3
750	750 SS	2003-2004	HBC1106	Set Up RACE	1	1		1		3
800	800 Sport	2003-2004	HBC1109	Set Up RACE	1	1		1		3
800	800 SS	2003-2004	HBC1108	Set Up RACE	1	1		1		3
800	800 SS	2003-2004	HBC1210	Set Up OEM anteriore	1	1	1	1		4
800	S2R 800	2004-2008	HBC1184	Set Up OEM anteriore	1	1	1	1		4
800	S2R 800	2007-2008	HBC1185	Set Up RACE	1	1		1		3
848	848	2008-2009	HBC1205	Set Up sopra parafango anteriore	1	1		1		3
848	848	2008-2009	HBC1206	Set Up RACE	1	1		1		3
848	848 / 848 EVO	2008-2013	HBC1206	Linea frizione					1	1
848	848 Evo	2010-2013	HBC1214	Set Up sopra parafango anteriore	1	1		1		3
848	848 Evo	2010-2013	HBC1215	Set Up RACE	1	1		1		3
848	848 Streetfighter	2012-2013	HBC1221	Linea frizione					1	1
848	848 Streetfighter	2012-2013	HBC1221	Set Up RACE	1	1		1		3

CILIND.	MODELLO	ANNI	CODICE	CONFIGURAZIONE	ANT. SUP.	ANT. INF.	AGG.	POST.	FRIZ.	TOT. TUBI
848	848 Streetfighter	2012-2013	HBK1222	Set Up sopra parafango anteriore	1	1		1		3
851	851	1988-1991	HBC0967	Linea frizione					1	1
851	851 SP1 & SP2	1992-1993	HBK0967	Set Up OEM anteriore	1	1		1		3
851	851 Strada	1987-1989	HBK0966	Set Up OEM anteriore	1	2		1		4
851	851 Strada	1992-1993	HBK0968	Set Up OEM anteriore	1	1		1		3
860	860 Darmah	1982	HBK0969	Set Up OEM anteriore	1	2		2		5
860	860 MHR	1981	HBK0973	Set Up OEM anteriore	1	2		1		4
860	860 GT	1974-1975	HBK0971	Set Up OEM anteriore	1	2				3
860	860 GTS	1976-1978	HBK0972	Set Up OEM anteriore	1	2				3
888	888 SP2	1980	HBK1217	Set Up OEM anteriore	1	2		1		4
888	888 Strada	1992-1994	HBC1126	Linea frizione					1	1
888	888 Strada	1992-1994	HBK1126	Set Up OEM anteriore	1	1		1		3
899	899 Panigale ABS	2014-2015	HBK1899	Set Up OEM anteriore	1	1	1	1		4
899	899 / 1199 Panigale	2012-2014	HBC1899	Linea frizione					1	1
900	900 GTS	1976-1978	HBK1211	Set Up OEM anteriore	1	2				3
900	900 S2	1985	HBK0982	Set Up OEM anteriore	1	2		1		4
900	900 S2	1983-1984	HBK0981	Set Up OEM anteriore	1	2		1		4
900	900 SD Darmah Supersport	1978	HBK1199	Set Up OEM anteriore	1	2		1		4
900	900 SD Darmah Supersport	1980	HBK0979	Set Up OEM anteriore	1	2	1	1		5
900	900 SD Darmah Supersport	1981	HBK0980	Set Up OEM anteriore	1	2		1		4
900	900 SL	1991-1993	HBK1160	Set Up RACE	1	1		1		3
900	900 SL	1991-2002	HBC1160	Linea frizione					1	1
900	900 SL pinza inferiore	1994-1997	HBK1157	Set Up RACE	1	1		1		3
900	900 Sport	1989	HBC0986	Linea frizione					1	1
900	900 Sport	1989	HBK0986	Set Up OEM anteriore	1	2		1		4
900	900 Sport	2003	HBK1105	Set Up RACE	1	1		1		3
900	900 SS	2003	HBK1104	Set Up RACE	1	1		1		3
900	900 SS	1978-1980	HBK0987	Set Up OEM anteriore	1	2		1		4
900	900 SS	1981-1990	HBK0989	Set Up OEM anteriore	1	2		1		4
900	900 SS	1991-1993	HBK1163	Set Up RACE	1	1		1		3
900	900 SS	1991-2002	HBC1163	Linea frizione					1	1
900	900 SS	1994-1997	HBK1153	Set Up RACE	1	1		1		3
900	900 SS	1998-2002	HBK1193	Set Up OEM anteriore	1	1		1		3
900	900 SS Desmo	1974	HBK0991	Set Up OEM anteriore	1	2		1		4
900	900 SS MHR	1981	HBK1219	Set Up OEM anteriore	1	2		1		4
900	900 SS pinza inferiore - posteriore	2002	HBK1120	Set Up RACE	1	1		1		3
900	900 Superlight II	1998-2002	HBK1149	Set Up RACE	1	1		1		3
900	900 Superlight IV	2004-2005	HBK1220	Set Up RACE	1	1		1		3
900	M900	1993-2000	HBC1056	Linea frizione					1	1
900	M900 Monster	1993-1999	HBK1167	Set Up RACE	1	1		1		3
900	M900 Monster	1993-1999	HBK1056	Set Up OEM anteriore	1	2		1		4
900	MHR900R	1983-1984	HBC1224	Linea frizione					1	1
900	MHR900R	1983-1984	HBK1224	Set Up OEM anteriore	1	2		1		4
906	906 Paso	1986-1994	HBC1128	Linea frizione					1	1
906	906 Paso	1986-1994	HBK1128	Set Up OEM anteriore	1	2		1		4
906	906 Paso	1986-1994	HBK1173	Set Up RACE	1	1		1		3
907	907 IE	1991-1994	HBK1000	Set Up OEM anteriore	1	2		1		4
916	916 BIP / Strada / SP / SPS	1994-2000	HBC1004	Linea frizione					1	1

CILIND.	MODELLO	ANNI	CODICE	CONFIGURAZIONE	ANT. SUP.	ANT. INF.	AGG.	POST.	FRIZ.	TOT. TUBI
916	916 Biposto / SPS	1998-2000	HBK1014	Set Up RACE	1	1		1		3
916	916 Biposto / Strada / SP	1994-1997	HBK1009	Set Up RACE	1	1		1		3
916	916 Biposto / Strada / SP	1994-1997	HBK1004	Set Up OEM anteriore	1	1	1	1		4
916	Monster S4	2001-2007	HBC1168	Linea frizione					1	1
916	Monster S4	2001-2007	HBK1169	Set Up RACE	1	1		1		3
916	Monster S4	2001-2007	HBK1168	Set Up OEM anteriore	1	1	1	1		4
916	Monster S4S	2004-2007	HBC1197	Linea frizione					1	1
916	ST4	1998-2002	HBK1095	Set Up RACE	1	1		1		3
916	ST4	1998-2002	HBK1082	Set Up OEM anteriore	1	1	1	1		4
916	ST4	1998-2004	HBC1072	Linea frizione					1	1
939	Hypermotard 939 / SP ABS	2016-2018	HBK0908	Set Up OEM anteriore	1	1	1	1		4
939	Supersport / Supersport S ABS	2017-2019	HBK0916	Set Up OEM anteriore	3			2		5
944	ST2	1997-2002	HBK1077	Set Up RACE	1	1		1		3
944	ST2	1997-2002	HBK1072	Set Up OEM anteriore	1	1	1	1		4
944	ST2	1998-2004	HBC1072	Linea frizione					1	1
996	996	1999-2000	HBK1175	Set Up RACE	1	1		1		3
996	996 Biposto / SPS	1998-2001	HBK1174	Set Up RACE	1	1		1		3
996	996 Biposto / SPS / R	1999-2002	HBK1174	Linea frizione					1	1
996	996 R	2001	HBK1216	Set Up RACE	1	1		1		3
996	Monster S4R	2005-2010	HBC1212	Linea frizione					1	1
996	Monster S4R	2005-2010	HBK1213	Set Up RACE	1	1		1		3
996	Monster S4R	2005-2010	HBK1212	Set Up OEM anteriore	1	1	1	1		4
998	998	2002-2004	HBK1164	Linea frizione					1	1
998	998	2002-2004	HBK1164	Set Up RACE	1	1		1		3
998	999	2003-2006	HBK1099	Set Up sopra parafango anteriore	1	1		1		3
998	998R	2002-2004	HBK1162	Set Up OEM anteriore	1	1	1	1		4
998	998S	2002-2004	HBK1207	Set Up RACE	1	1		1		3
998	999S	2003-2006	HBC1202	Linea frizione					1	1
998	999S	2003-2004	HBK0906	Set Up sopra parafango anteriore	1	1		1		3
998	999S	2005-2006	HBK1202	Set Up sopra parafango anteriore	1	1		1		3
998	999S	2003-2004	HBK0907	Set Up RACE	1	1		1		1
998	999S	2005-2006	HBK1203	Set Up RACE	1	1		1		3
998	Monster S4S	2004-2007	HBK1198	Set Up RACE	1	1		1		3
998	Monster S4S	2004-2007	HBK1197	Set Up OEM anteriore	1	1	1	1		4
1000	1000 MHR Mille	1979-1984	HBC1204	Linea frizione					1	1
1000	1000 MHR Mille	1985-1987	HBK1204	Set Up OEM anteriore	1	2		1		4
1000	1000 SS Paul Smart Replica	2008-2009	HBC1194	Linea frizione					1	1
1000	1000 SS Paul Smart Replica	2008-2009	HBK1194	Set Up OEM anteriore	1	1	1			3
1000	1000DS Multistrada	2003-2006	HBC1101	Linea frizione					1	1
1000	1000DS Multistrada	2003-2006	HBK1101	Set Up RACE	1	1		1		3
1000	GT1000	2007-2010	HBK1218	Set Up OEM anteriore	1	1	1			3
1000	S2R 1000	2007-2008	HBK1187	Set Up RACE	1	1		1		3
1000	S2R 1000	2007-2008	HBK1186	Set Up OEM anteriore	1	1	1	1		4
1000	S2R 1000 / 800	2004-2008	HBC1186	Linea frizione					1	1
1100	Monster 1100S	2009-2010	HBC0903	Linea frizione					1	1
1100	Monster 1100S	2009-2010	HBK0903	Set Up OEM anteriore	1	1		1		3
1200	Multistrada 1200S	2010-2014	HBC0904	Linea frizione					1	1

CILIND.	MODELLO	ANNI	CODICE	CONFIGURAZIONE	ANT. SUP.	ANT. INF.	AGG.	POST.	FRIZ.	TOT. TUBI
1200	Multistrada 1200S ABS	2015-2016	HBK1901	Set Up OEM anteriore	1	1	1	1		4
1098	1098	2007-2008	HBC1073	Linea frizione					1	1
1098	1098 / S / Tricolore	2007-2008	HBK1192	Set Up sopra parafango anteriore	1	1		1		3
1098	1098 / S / Tricolore	2007-2008	HBK1195	Set Up RACE	1	1		1		3
1098	Streetfighter 1098	2010-2013	HBC1222	Linea frizione					1	1
1100	Hypermotard 1100	2007-2010	HBK1180	Set Up sopra parafango anteriore	1	1		1		3
1100	Hypermotard 1100	2007-2010	HBK1181	Set Up RACE	1	1		1		3
1100	Hypermotard 1100	2007-2010	HBK1200	Set Up OEM anteriore	1	1	1	1		4
1100	Hypermotard 1100 EVO SP	2010-2012	HBC1003	Linea frizione					1	1
1100	Hypermotard 1100 EVO SP	2010-2012	HBK1003	Set Up sopra parafango anteriore	1	1				2
1100	Multistrada 1100 / S	2007-2010	HBC1188	Linea frizione					1	1
1100	Multistrada DS	2008	HBFKK0011	Set Up OEM anteriore	3			1		4
1100	Panigale 1199 / 1299	2012-2016	HBFKK0009	Set Up RACE	2			1		3
1100	Panigale V4	2017-2018	HBFKK0008	Set Up RACE	3			1		4
1198	1198	2009-2012	HBK1208	Set Up sopra parafango anteriore	1	1		1		3
1198	1198	2009-2012	HBK1209	Set Up RACE	1	1		1		3
1199	1199 Panigale ABS	2012-2014	HBK1900	Set Up OEM anteriore	4			2		6
1200	Diavel / Carbon 2013	2011-2013	HBC0920	Linea frizione					1	1
ENFIELD										
350	Machismo 350	2000-2005	HBK1280	Set Up OEM anteriore	1					1
GARINNI										
125	GR125 ST	2010	HBK1290	Set Up OEM anteriore	1			1		2
125	GR125 T3	2010	HBK1292	Set Up OEM anteriore	1					1
150	GR150 ST	2010	HBK1291	Set Up OEM anteriore	1			1		2
150	GR150 TI	2010	HBK1293	Set Up OEM anteriore	1					1
250	GR250 T3	2010	HBK1294	Set Up OEM anteriore	1			1		2
GAS GAS										
200	EC200	2000-2005	HBC1301	Linea frizione					1	1
200	EC200 Enduro	1996-2002	HBK1302	Set Up OEM anteriore	1			1		2
250	EC250	2008	HBK1304	Set Up OEM anteriore	1			1		2
250	EC250	1996-2002	HBK1303	Set Up OEM anteriore	1			1		2
250	EC250	2000-2005	HBC1301	Linea frizione					1	1
250	EC250 Enduro	1996-2002	HBK1302	Set Up OEM anteriore	1			1		2
270	270 TXT	1999-2003	HBK1305	Set Up OEM anteriore	1					1
300	EC300	1996-2002	HBK1301	Set Up OEM anteriore	1			1		2
300	EC300	2000-2005	HBC1301	Linea frizione					1	1
300	EC300 Enduro	1996-2002	HBK1302	Set Up OEM anteriore	1			1		2
	Moto Cross	2000	HBK1300	Set Up OEM anteriore	1			1		2
GILERA										
50	DNA 50	2000-2005	HBK1406	Set Up OEM anteriore	1			1		2
50	GSM50	2000-2001	HBK1401	Set Up OEM anteriore	1					1
125	DNA 125	2000-2005	HBK1407	Set Up OEM anteriore	1			1		2
125	GFR125	1993-1994	HBK1400	Set Up OEM anteriore	1					1
125	Runner FX125	1997-2001	HBK1402	Set Up OEM anteriore	1			1		2
125	Runner VX125	2000-2005	HBK1409	Set Up OEM anteriore	1					1

CILIND.	MODELLO	ANNI	CODICE	CONFIGURAZIONE	ANT. SUP.	ANT. INF.	AGG.	POST.	FRIZ.	TOT. TUBI
180	Runner FXR180	1998-2001	HBK1403	Set Up OEM anteriore	1			1		2
180	Runner FXR180 SP	2000-2001	HBK1404	Set Up OEM anteriore	1			1		2
200	Runner VXR200	2003-2010	HBK1410	Set Up OEM anteriore	1			1		2
500	Saturno 500	1990-1993	HBK1405	Set Up OEM anteriore	1			1		2
600	Nord West 600	1991-1993	HBK1408	Set Up OEM anteriore	1	1		1		3
HARLEY DAVIDSON										
500	FLHXI Street Glide	2006-2007	HBK1506	Set Up OEM anteriore	1	2				3
750	XG750 Street 750	2016	HBK1501	Set Up OEM anteriore	1			1		2
883	883 Hugger	2005-2011	HBF1821	Set Up OEM anteriore	1					1
883	XL883 Nightstar Iron	2008-2013	HBF1825	Set Up OEM anteriore	1					1
883	XLH Hugger 883	1987-2001	HBK1757	Set Up OEM anteriore	1			1		2
883	XLH Sportster 883	1985-2002	HBK1783	Set Up OEM anteriore	1			1		2
883	XLH Sportster 883	2003-2005	HBK1811	Set Up OEM anteriore	1	2		1		4
883	XLH Sportster 883	2006-2011	HBK1809	Set Up OEM anteriore	1	2				3
883	XLH Sportster 883R	2002-2005	HBK1812	Set Up RACE	1	1		1		3
883	XLH Sportster De Luxe 883	1985-1992	HBK1800	Set Up OEM anteriore	1			1		2
1000	XLH 1000	1978-1985	HBK1749	Set Up OEM anteriore	1	2				3
1000	XLS 1000	1984-1985	HBF1808	Set Up OEM anteriore	1					1
1200	XL1200 Sportster	2006-2011	HBK1816	Set Up OEM anteriore	1			1		2
1200	XL1200 X-48	2010-2011	HBF1824	Set Up OEM anteriore	1					1
1200	XL1200C Sportster Custom - doppio disco	1995-2001	HBK1734	Set Up OEM anteriore	1	2		1		4
1200	XL1200C Sportster Custom - Standard	1995-2001	HBK1735	Set Up OEM anteriore	1			1		2
1200	XL1200S Sportster Sport	1999-2001	HBK1742	Set Up OEM anteriore	1	2		1		4
1200	XLH Sportster 1200	1987-1996	HBK1772	Set Up OEM anteriore	1			1		2
1200	XLH Sportster 1200	1997-1999	HBK1780	Set Up OEM anteriore	1			1		2
1200	XLH1200	2001-2003	HBK1826	Set Up OEM anteriore	1	2				3
1200	XR1200	2008-2010	HBK1502	Set Up sopra parafrangente anteriore	1	1		1		3
1200	XR1200	2008-2010	HBK1819	Set Up OEM anteriore	1	2		1		4
1584	FXDF1584 Fat Bob	2007-2010	HBK1827	Set Up OEM anteriore	1	2		1		4
	FLHC Electra Glide Classic	1982-1984	HBK1500	Set Up OEM anteriore	1	2	1	1		5
	FLHR Road King	1994-2001	HBK1503	Set Up OEM anteriore	1	2	1	1		5
	FLHR Road King Injection	1995-1997	HBK1508	Set Up OEM anteriore	1	2	1	1		5
	FLHS Electra Glide Sport	1987-1992	HBK1511	Set Up OEM anteriore	1	2	1	1		5
	FLHTC Electra Glide Classic	1985-1993	HBK1517	Set Up OEM anteriore	1	2	1	1		5
	FLHTC Electra Ultra Glide Classic	2000-2006	HBK1822	Set Up OEM anteriore	1	2		1		4
	FLHTC-U Ultra Classic Electra Glide	1988-1994	HBK1526	Set Up OEM anteriore	1	2	1	1		5
	FLHTC-UI Ultra Classic Electra Glide	1995-2001	HBK1533	Set Up OEM anteriore	1	2		1		4
	FLST Heritage Softail	1986-1990	HBK1540	Set Up OEM anteriore	1		1	1		3
	FLSTC Heritage Softail Classic	1987-2003	HBK1545	Set Up OEM anteriore	1		1	1		3
	FLSTF Fat Boy	1989-2006	HBK1558	Set Up OEM anteriore	1		1	1		3
	FLSTF Fat Boy	2007-2011	HBF1823	Set Up OEM anteriore	1					1
	FLSTI Heritage	2006-2006	HBF1541	Set Up OEM anteriore	1					1
	FLSTN Heritage Softail Nostalgia	1993-1998	HBK1569	Set Up OEM anteriore	1		1	1		3
	FLTC Tour Glide Classic	1984-1993	HBK1575	Set Up OEM anteriore	1	2	1	1		5

CILIND.	MODELLO	ANNI	CODICE	CONFIGURAZIONE	ANT. SUP.	ANT. INF.	AGG.	POST.	FRIZ.	TOT. TUBI
	FLTC-U Ultra Classic Tour Glide	1988-1991	HBK1585	Set Up OEM anteriore	1	2	1	1		5
	FLTRI Road Glide	1998-2000	HBK1813	Set Up OEM anteriore	1	2	1	1		5
	FXD Super Glide	1994-1997	HBK1589	Set Up OEM anteriore	1			1		2
	FXDB Dyna Daytona	1991-1993	HBK1593	Set Up OEM anteriore	1	2		1		4
	FXDB Street Bob	2006-2010	HBK1814	Set Up OEM anteriore	1			1		2
	FXDC Dyna Glide Custom	1991-1993	HBK1596	Set Up OEM anteriore	1	2		1		4
	FXDC Dyna Super Glide Custom	2008-2010	HBK1818	Set Up OEM anteriore	1					1
	FXDL Dyna Lowrider	1992-1998	HBK1599	Set Up OEM anteriore	1	2		1		4
	FXDL Dyna Lowrider	1999-2001	HBK1507	Set Up OEM anteriore	1	2				3
	FXDS-C Dyna Low Rider Convertible	1994-1997	HBK1605	Set Up OEM anteriore	1	2		1		4
	FXDWG Dyna Wide Glide	1992-2001	HBK1609	Set Up OEM anteriore	1			1		2
	FXDX Dyna Super Glide Sport	1998-2007	HBK1619	Set Up OEM anteriore	1	2		1		4
	FXDX Super Glide Sport	1998-2001	HBK1623	Set Up OEM anteriore	1	2		1		4
	FXE Super Glide	1980-1984	HBK1627	Set Up OEM anteriore	1			1		2
	FXEF Super Glide Fat Bob	1984-1985	HBK1632	Set Up OEM anteriore	1			1		2
	FXLR Low Rider Custom	1991-1994	HBK1634	Set Up OEM anteriore	1		1	1		3
	FXR Super Glide Custom	1985-1994	HBK1638	Set Up OEM anteriore	1			1		2
	FXRS Low Rider	1991-1992	HBK1648	Set Up OEM anteriore	1		1	1		3
	FXRS Super Glide	1982-1990	HBK1650	Set Up OEM anteriore	1		1	1		3
	FXRS-C Low Rider Convertible	1989-1993	HBK1660	Set Up OEM anteriore	1	2	1	1		5
	FXRS-SP Low Rider Sport	1985-1993	HBK1665	Set Up OEM anteriore	1	2	1	1		5
	FXRT Sport Glide Tourer	1983-1993	HBK1674	Set Up OEM anteriore	1	1	1	1		4
	FXRT Super Glide Fat Bob	1985	HBK1684	Set Up OEM anteriore	1	2	1	1		5
	FXSB Low Rider	1982-1984	HBK1685	Set Up OEM anteriore	1		1	1		3
	FXST Softail	1983-1990	HBK1688	Set Up OEM anteriore	1		1	1		3
	FXST Softail Standard	1998-2002	HBK1696	Set Up OEM anteriore	1		1	1		3
	FXSTB Night Train Soft Tail	2000-2007	HBK1815	Set Up OEM anteriore	1			1		2
	FXSTB Softail Night Train	1998-1999	HBK1698	Set Up OEM anteriore	1		1	1		3
	FXSTC Softail Custom	1985-1998	HBK1700	Set Up OEM anteriore	1		1	1		3
	FXSTC Softail Custom	2008-2010	HBK1817	Set Up OEM anteriore	1					1
	FXSTS SE3 CVO Softail Springer	2009	HBK1801	Set Up OEM anteriore	1					1
	FXSTS Springer Softail	1988-1998	HBK1714	Set Up OEM anteriore	1		1	1		3
	FXSTS Softail Springer	2009	HBK1801	Linea frizione					1	1
	FXSTSB Bad Boy	1994-1996	HBK1725	Set Up OEM anteriore	1		1	1		3
	FXWG Wide Glide	1980-1985	HBK1728	Set Up OEM anteriore	1	2	1	1		5
	MT350	1993-2000	HBK1505	Set Up OEM anteriore	1			1		2
	Sportster Low	2009-2010	HBK1820	Set Up OEM anteriore	1					1
	V-Rod VRSC	2001-2006	HBK1810	Linea frizione					1	1
	V-Rod VRSC	2001-2006	HBK1810	Set Up OEM anteriore	1	2	1	1		5
	VRSCDX Night Rod Special	2007-2010	HBK1504	Linea frizione					1	1
	VRSCDX Night Rod Special	2007-2010	HBK1504	Set Up OEM anteriore	1	2		1		4
	XL53C Sportster Custom 53	1998-2001	HBK1745	Set Up OEM anteriore	1			1		2
HONDA										
50	NSC50R	2013-2017	HBK2052	Set Up OEM anteriore	1			1		2
50	XR50 / XR100 Motard	2005-2009	HBK2561	Set Up OEM anteriore	1					1
80	CR80	1998-2002	HBK2757	Set Up OEM anteriore	1			1		2
80	MBX80 FWDD	1983-1986	HBK2280	Set Up OEM anteriore	1	2				3

CILIND.	MODELLO	ANNI	CODICE	CONFIGURAZIONE	ANT. SUP.	ANT. INF.	AGG.	POST.	FRIZ.	TOT. TUBI
125	ANF125i Innova	2003-2009	HBF2770	Set Up OEM anteriore	1					1
125	CB125R-SD	1983-1986	HBF2031	Set Up OEM anteriore	1					1
125	CB125T-DC Superdream	1982-1988	HBF2035	Set Up OEM anteriore	1					1
125	CBF125	2009	HBF2826	Set Up OEM anteriore	1					1
125	CBR125R	2004-2010	HBK2672	Set Up OEM anteriore	1			1		2
125	CBR125R	2011-2016	HBK2872	Set Up OEM anteriore	1			1		2
125	CG125 ES4 ES8	2004-2008	HBF2820	Set Up OEM anteriore	1					1
125	CG125 Titan ES	2000-2004	HBF2846	Set Up OEM anteriore	1					1
125	CLR125 City Fly	1998-2003	HBF2671	Set Up OEM anteriore	1					1
125	CR125	1992-1994	HBK2707	Set Up OEM anteriore	1			1		2
125	CR125	1995-2003	HBK2705	Set Up OEM anteriore	1			1		2
125	CR125	2004-2006	HBK2716	Set Up OEM anteriore	1			1		2
125	CR125 R	2006-2008	HBK2759	Set Up OEM anteriore	1			1		2
125	MBX125 F-E	1984-1985	HBF2278	Set Up OEM anteriore	1					1
125	ML125	1980-1985	HBF2841	Set Up OEM anteriore	1					1
125	ML125	1986-2000	HBF2842	Set Up OEM anteriore	1					1
125	MSX125 - Non ABS	2013-2017	HBK2295	Set Up OEM anteriore	1			1		2
125	MSX125 ABS	2017-2020	HBK2296	Set Up OEM anteriore	2			2		4
125	MSX125 ABS	2021-2022	HBK2057	Set Up OEM anteriore	3			1		4
125	MTX125 RWF - WL	1985-1994	HBF2284	Set Up OEM anteriore	1					1
125	NS125 FG - FH	1986-1990	HBK2298	Set Up OEM anteriore	1			1		2
125	NS125 RK - RL Supersport	1988-1989	HBK2305	Set Up OEM anteriore	1	2		1		4
125	NSR125 RK - R3	1990-2003	HBK2311	Set Up OEM anteriore	1			1		2
125	RS125	2009	HBK2850	Set Up OEM anteriore	1			1		2
125	RS125	1989-1994	HBF2347	Set Up OEM anteriore	1					1
125	RS125 W Road Racer	1991	HBK2348	Set Up OEM anteriore	2			1		3
125	SES125 Dylan	2000-2007	HBF2771	Set Up OEM anteriore	1					1
125	SH125	2001-2004	HBF2016	Set Up OEM anteriore	1					1
125	SH125i	2005-2008	HBF2766	Set Up OEM anteriore	1					1
125	VT125C Shadow	2004-2008	HBF2683	Set Up OEM anteriore	1					1
125	XL125 RF	1985-1987	HBF2534	Set Up OEM anteriore	1					1
125	XL125 RT	1980	HBF2536	Set Up OEM anteriore	1					1
125	XL125V Varadero	2000-2003	HBK2876	Set Up OEM anteriore	1			1		2
125	XL125V Varadero	2004-2005	HBK2682	Set Up OEM anteriore	1			1		2
125	XL125V Varadero	2007-2008	HBK2775	Set Up OEM anteriore	1			1		2
125	XR125L	2003-2008	HBF2781	Set Up OEM anteriore	1					1
125	RS125	1995-2003	HBK2021	Set Up OEM anteriore	1			1		2
125	Z125 Monkey ABS - Z125MAK	2018-2020	HBK2036	Set Up OEM anteriore	3			1		4
150	CBX150 Aero	1990-1997	HBF2838	Set Up OEM anteriore	1					1
150	CG150 Titan	2009-2010	HBF2840	Set Up OEM anteriore	1					1
150	CRF150R	2007-2017	HBK2760	Set Up OEM anteriore	1			1		2
150	NXR150 Bros ESD	2000-2010	HBF2845	Set Up OEM anteriore	1					1
200	MTX200 RWD	1983-1986	HBF2294	Set Up OEM anteriore	1					1
200	XLR200	1995-2009	HBF2824	Set Up OEM anteriore	1					1
200	XR200	1995-2009	HBF2825	Set Up OEM anteriore	1					1
230	CRF230F	2003-2015	HBF2778	Set Up OEM anteriore	1					1
250	250 RSB		HBF2002	Set Up OEM anteriore	1					1
250	ATC250 R	1983	HBK2010	Set Up OEM anteriore	1			1		2
250	ATC250R	1986	HBK2867	Set Up OEM anteriore	1			1		2

CILIND.	MODELLO	ANNI	CODICE	CONFIGURAZIONE	ANT. SUP.	ANT. INF.	AGG.	POST.	FRIZ.	TOT. TUBI
250	CB250N A B DXB Superdream	1980-1983	HBF2043	Set Up OEM anteriore	1					1
250	CB250RS-A	1980-1983	HBF2049	Set Up OEM anteriore	1					1
250	CB250RS-DC Deleuxe	1982-1984	HBF2053	Set Up OEM anteriore	1					1
250	CBF250 Hornet	1996-2006	HBK2701	Set Up OEM anteriore	1			1		2
250	CBF250 Hornet	2004-2007	HBK2677	Set Up OEM anteriore	1			1		2
250	CBR250 RRJ - RRK MC19	1988-1989	HBK2809	Set Up OEM anteriore	1			1		2
250	CBR250 RRM - RRX MC22	1990-1999	HBK2746	Set Up RACE	1	1		1		3
250	CBR250R	2011-2013	HBK2873	Set Up RACE	1			1		2
250	CBR250R ABS	2011-2013	HBK2015	Set Up OEM anteriore	3			2		5
250	CBX250 RSE	1984-1986	HBF2812	Set Up OEM anteriore	1					1
250	CBX250 Twister	2000-2010	HBF2834	Set Up OEM anteriore	1					1
250	CBX250 Twister	2001-2008	HBF2839	Set Up OEM anteriore	1					1
250	CJ250 T	1977-1978	HBK2200	Set Up OEM anteriore	1	1				2
250	CM250 TB Custom	1982-1984	HBF2202	Set Up OEM anteriore	1					1
250	CMX250		HBF2900	Set Up OEM anteriore	1					1
250	CR250	1992-1994	HBK2706	Set Up OEM anteriore	1			1		2
250	CR250	1995-1998	HBK2206	Set Up OEM anteriore	1			1		2
250	CR250	1999-2003	HBK2013	Set Up OEM anteriore	1			1		2
250	CR250	2004-2007	HBK2715	Set Up OEM anteriore	1			1		2
250	CR250 RH - RJ	1987-1988	HBK2346	Set Up OEM anteriore	1			1		2
250	CR250 RK	1989	HBK2345	Set Up OEM anteriore	1			1		2
250	CR250R	1990-1991	HBK2853	Set Up OEM anteriore	1			1		2
250	CRF250L	2013-2016	HBK2877	Set Up OEM anteriore	1			1		2
250	CRF250L ABS	2017-2019	HBK2037	Set Up OEM anteriore	2			2		4
250	CRF250R	2004-2007	HBK2818	Set Up OEM anteriore	1			1		2
250	CRF250R	2008-2009	HBK2789	Set Up OEM anteriore	1			1		2
250	CRF250R	2010-2017	HBK2860	Set Up OEM anteriore	1			1		2
250	CRF250X	2004-2005	HBK2816	Set Up OEM anteriore	1			1		2
250	CRF250X	2006-2013	HBK2758	Set Up OEM anteriore	1			1		2
250	CRM250	1996-1998	HBK2576	Set Up OEM anteriore	1			1		2
250	Forza 250	2000-2003	HBK2755	Set Up OEM anteriore	1	1	1	1		4
250	NSF250R - Moto 3	2011-2016	HBK2001	Set Up OEM anteriore	1			1		2
250	NSR250 (MC16)	1986-1987	HBK2869	Set Up RACE	1	1		1		3
250	NSR250 (MC16)	1986-1987	HBK2868	Set Up OEM anteriore	1	1	1	1		4
250	NSR250 (MC18 R/SP) R2J - R4J	1988-1988	HBK2815	Set Up OEM anteriore	1	1		1		3
250	NSR250 (MC18 R/SP) R5K - R6K	1989-1989	HBK2714	Set Up OEM anteriore	1	1		1		3
250	NSR250 (MC21 R/SE/SP)	1990-1993	HBK2712	Set Up OEM anteriore	1	1		1		3
250	NSR250 (MC28 R/SE/SP)	1994-1998	HBK2713	Set Up OEM anteriore	1	1		1		3
250	NSR250R Twin Disc Import	1993-1996	HBK2319	Set Up OEM anteriore	1	1		1		3
250	Quad : TRX250EX	2003-2006	HBK2702	Set Up RACE	1	1		1		3
250	RS250	1996	HBK2747	Set Up RACE	1	1		1		3
250	VT250 FD	1983-1987	HBF2481	Set Up OEM anteriore	1					1
250	VTR250 Y (MC33)	2000-2003	HBK2786	Set Up OEM anteriore	1			1		2
250	XR250L	2004	HBK2848	Set Up OEM anteriore	1			1		2
250	XR250R	1997-2005	HBK2603	Set Up OEM anteriore	1			1		2
250	CRM250	1991-1992	HBK2022	Set Up OEM anteriore	1			1		2
300	CB300R	2008-2010	HBF2835	Set Up OEM anteriore	1					1
300	Quad : TRX300EX	2002-2006	HBK2703	Set Up RACE	1	1		1		3

CILIND.	MODELLO	ANNI	CODICE	CONFIGURAZIONE	ANT. SUP.	ANT. INF.	AGG.	POST.	FRIZ.	TOT. TUBI
300	XRE300	2008-2010	HBK2836	Set Up OEM anteriore	1			1		2
350	CB350S-G	1986-1988	HBK2056	Set Up OEM anteriore	1	2				3
350	NX350	1998-2006	HBK2843	Set Up OEM anteriore	1					1
350	XL350R	1989	HBK2538	Set Up OEM anteriore	1					1
360	CB360 Removing Hardline	1973	HBK2575	Set Up OEM anteriore	1	1				2
360	CB360 Retaining Hardline	1973	HBK2577	Set Up OEM anteriore	1	1				2
400	Bros 400	1988-1995	HBK2650	Set Up OEM anteriore	1			1		2
400	CB1 (400) NC27	1989-1993	HBK2804	Set Up OEM anteriore	1			1		2
400	CB1 (Super 400) NC31	1992-1996	HBK2748	Set Up RACE	1	1		1		3
400	CB400 / 4 F2	1978	HBK2063	Set Up OEM anteriore	1	1				2
400	CB400 F	1975-1977	HBK2059	Set Up OEM anteriore	1	2				3
400	CB400 F Twin Disc	1989-1990	HBK2060	Set Up OEM anteriore	1	1				2
400	CB400 SF	1995	HBK2649	Set Up OEM anteriore	1	1		1		3
400	CB400 Super Four	1998-2000	HBK2751	Set Up sopra parafango anteriore	1	1		1		3
400	CB400 Super Four	1998-2000	HBK2752	Set Up RACE	1	1		1		3
400	CB400 Super Four VTEC 1 And 2	2001-2004	HBK2753	Set Up sopra parafango anteriore	1	1		1		3
400	CB400 Super Four VTEC 1 And 2	2001-2004	HBK2754	Set Up RACE	1	1		1		3
400	CB400 T	1977	HBK2062	Set Up OEM anteriore	1					1
400	CB400F Super Four Import	1998	HBK2064	Set Up OEM anteriore	1	1		1		3
400	CB400N Superdream	1978-1981	HBK2061	Set Up OEM anteriore	1	2				3
400	CBR400R	1985-1987	HBK2115	Set Up OEM anteriore	1	2				3
400	CBR400RR Gullarm NC29	1989-1996	HBK2119	Set Up RACE	1	1		1		3
400	CBR400RR Gullarm NC29	1989-1996	HBK2118	Set Up OEM anteriore	1	1	1	1		4
400	CBR400RR Triarm NC23	1988-1989	HBK2134	Set Up RACE	1	1		1		3
400	NS400 RF - RG	1985-1988	HBK2307	Set Up OEM anteriore	1	2		1		4
400	NX4 Falcon	2000-2010	HBK2844	Set Up OEM anteriore	1			1		2
400	Quad : TRX400EX	2003-2003	HBK2691	Set Up RACE	1	1		1		3
400	Quad : TRX400EX	2004-2006	HBK2704	Set Up RACE	1	1		1		3
400	RVF400R (NC35)	1994-1996	HBK2350	Set Up RACE	1	1		1		3
400	RVF400R (NC35)	1994-1996	HBK2349	Set Up OEM anteriore	1	1	1	1		4
400	VF400F D	1982-1984	HBK2428	Linea frizione					1	1
400	VF400F D	1982-1984	HBK2428	Set Up OEM anteriore	1			1		2
400	VFR400R (NC21) Import	1985-1987	HBK2451	Linea frizione					1	1
400	VFR400R (NC21) Import	1985-1987	HBK2451	Set Up OEM anteriore	1	2		1		4
400	VFR400R (NC24) Import	1987-1989	HBK2454	Set Up OEM anteriore	1	1		1		3
400	VFR400R (NC30) Import	1989-1995	HBK2457	Set Up OEM anteriore	1	1		1		3
400	XR400R	1997-2005	HBK2601	Set Up OEM anteriore	1			1		2
450	CB450 DX	1989-1992	HBK2065	Set Up OEM anteriore	1	2		1		4
450	CB450 K5 USA Import	1972-1972	HBK2067	Set Up OEM anteriore	1	1				2
450	CBR450 SR	1988-1994	HBK2837	Set Up OEM anteriore	1	2		1		4
450	CMX450		HBK2862	Set Up OEM anteriore	1					1
450	CRF450	2002-2003	HBK2594	Set Up OEM anteriore	1			1		2
450	CRF450R	2004-2007	HBK2602	Set Up OEM anteriore	1			1		2
450	CRF450R	2008-2008	HBK2782	Set Up OEM anteriore	1			1		2
450	CRF450R	2009-2013	HBK2790	Set Up OEM anteriore	1			1		2
450	CRF450R	2014-2015	HBK2012	Set Up OEM anteriore	1			1		2
450	CRF450R (RK-RL)	2019-2020	HBK2050	Set Up OEM anteriore	1			1		2

CILIND.	MODELLO	ANNI	CODICE	CONFIGURAZIONE	ANT. SUP.	ANT. INF.	AGG.	POST.	FRIZ.	TOT. TUBI
450	CRF450X	2005-2007	HBK2788	Set Up OEM anteriore	1			1		2
450	CRF450X	2008-2015	HBK2861	Set Up OEM anteriore	1			1		2
450	Quad : TRX450	2003-2006	HBK2700	Set Up RACE	1	1		1		3
450	Quad : TRX450	2004-2006	HBK2743	Set Up OEM anteriore	1	1	1	1		4
450	Quad : TRX450 - ATV Only	2004-2006	HBK2744	Set Up OEM anteriore	1	1	1	1		4
450	Quad : TRX450 : Winrow Enduro	2004-2006	HBK2779	Set Up OEM anteriore	1	1	1	1		4
450	Quad : TRX450 : Winrow MX	2004-2006	HBK2780	Set Up OEM anteriore	1	1	1	1		4
500	CB500 K1	1972	HBK2827	Set Up OEM anteriore	1	1				2
500	CB500 R-T	1994-1996	HBK2863	Set Up OEM anteriore	1					1
500	CB500 SW - SX	1997-2002	HBK2068	Set Up OEM anteriore	1			1		2
500	CB500 V - W - X	1996-2001	HBK2066	Set Up OEM anteriore	1			1		2
500	CB500F ABS	2013-2015	HBK2398	Set Up OEM anteriore	2			2		4
500	CB500R ABS	2013-2014	HBK2399	Set Up OEM anteriore						4
500	CB500X ABS	2013-2018	HBK2400	Set Up OEM anteriore	2			2		4
500	CB500X ABS	2019-2020	HBK2048	Set Up OEM anteriore	2			2		4
500	CBF500	2004-2007	HBK2730	Set Up OEM anteriore	1			1		2
500	CBR500R ABS	2013-2015	HBK2401	Set Up OEM anteriore	2			2		4
500	CBR500R ABS	2016-2018	HBK2058	Set Up OEM anteriore	2			2		4
500	CR500	1985-1988	HBK2847	Set Up OEM anteriore	1			1		2
500	CR500	1992-1994	HBK2207	Set Up OEM anteriore	1			1		2
500	CR500	1995-2003	HBK2208	Set Up OEM anteriore	1			1		2
500	CR500	2004-2005	HBK2717	Set Up OEM anteriore	1			1		2
500	CX500	1978	HBK2784	Set Up OEM anteriore	1	2				3
500	CX500 A - B	1979-1982	HBK2209	Set Up OEM anteriore	1	2				3
500	CX500 CB Custom	1981-1984	HBK2213	Set Up OEM anteriore	1	2				3
500	CX500 EC Eurosport	1982-1984	HBK2217	Set Up OEM anteriore	1	2		1		4
500	CX500 ET Turbo	1982-1984	HBK2220	Set Up OEM anteriore	1	2		1		4
500	FT500 C	1982-1984	HBK2230	Set Up OEM anteriore	1			1		2
500	GB500 TT Cafe Racer	1989-1990	HBK2865	Set Up OEM anteriore	1					1
500	GL500 Silverwing	1982-1984	HBK2272	Set Up OEM anteriore	1	2				3
500	VF500 F2E	1984-1987	HBK2432	Set Up OEM anteriore	1	2		1		4
500	VT500 ED - EF	1983-1988	HBK2486	Set Up OEM anteriore	1					1
500	XBR500 F - SJ	1985-1989	HBK2528	Set Up OEM anteriore	1					1
500	XR500 RD-RE	1983-1984	HBK2024	Set Up OEM anteriore	1					1
500	CBF500 ABS	2004-2007	HBK2731	Set Up OEM anteriore	2			2		4
500	VF500 F2E (Retains metal hard line)	1984-1987	HBC2432	Linea frizione					1	1
550	CB550 F1 - F2	1977	HBK2072	Set Up OEM anteriore	1	1				2
550	CB550 F1 - F2	1977	HBK2073	Set Up OEM anteriore	1	1				2
550	CB550 K3	1977	HBK2077	Set Up OEM anteriore	1	1				2
550	CBX550 F2C - FD	1982-1986	HBK2184	Set Up OEM anteriore	1	2		1		4
600	Bros 600	1988-1995	HBK2658	Set Up OEM anteriore	1			1		2
600	CB600F Hornet	1998-2002	HBK2081	Set Up RACE	1	1		1		3
600	CB600F Hornet	2003-2006	HBK2694	Set Up RACE	1	1		1		3
600	CB600F Hornet	2007-2013	HBK2310	Set Up sopra parafango anteriore	1	1		1		3
600	CB600F Hornet	2007-2013	HBK2874	Set Up RACE	1	1		1		3
600	CB600F Hornet	2007-2013	HBK2308	Set Up OEM anteriore	1	1	1	1		4
600	CB600F Hornet ABS	2007-2013	HBK2773	Set Up OEM anteriore	6			2		8

CILIND.	MODELLO	ANNI	CODICE	CONFIGURAZIONE	ANT. SUP.	ANT. INF.	AGG.	POST.	FRIZ.	TOT. TUBI
600	CBF600	2004-2007	HBK2675	Set Up RACE	1	1		1		3
600	CBF600	2004-2007	HBK2676	Set Up sopra parafango anteriore	1	1		1		3
600	CBF600	2004-2007	HBK2674	Set Up OEM anteriore	1	1	1	1		4
600	CBF600 (Faired & Unfaired)	2008-2010	HBK2795	Set Up RACE	1	1		1		3
600	CBF600 ABS	2008-2013	HBK2832	Set Up OEM anteriore	5			2		7
600	CBR600 F1 - F7 Sport	2001-2007	HBK2158	Set Up RACE	1	1		1		3
600	CBR600 F1 - F7 Sport	2001-2007	HBK2159	Set Up sopra parafango anteriore	1	1		1		3
600	CBR600 F1 - F7 Sport	2001-2007	HBK2160	Set Up OEM anteriore	1	1	1	1		4
600	CBR600 FH - FJ - FK	1987-1989	HBK2136	Set Up OEM anteriore	1	2		1		4
600	CBR600 FL	1990-1990	HBK2139	Set Up OEM anteriore	1	2		1		4
600	CBR600 FM - FN - FP - FR	1991-1994	HBK2141	Set Up RACE	1	1		1		3
600	CBR600 FM - FN - FP - FR	1991-1994	HBK2140	Set Up OEM anteriore	1	1	1	1		4
600	CBR600 FS - FT - FW	1995-1998	HBK2622	Set Up RACE	1	1		1		3
600	CBR600 FS - FT - FW	1995-1998	HBK2624	Set Up sopra parafango anteriore	1	1		1		3
600	CBR600 FS - FT - FW - SPEC ON HOLD - DON'T USE	1995-1998	HBK2623	Set Up OEM anteriore	1	1	1	1		4
600	CBR600 FX - F3 And Sport	1999-2004	HBK2153	Set Up RACE	1	1		1		3
600	CBR600 FX - F3 And Sport	1999-2004	HBK2154	Set Up sopra parafango anteriore	1	1		1		3
600	CBR600 FX - F3 And Sport	1999-2004	HBK2155	Set Up OEM anteriore	1	1	1	1		4
600	CBR600F ABS	2011-2013	HBK2312	Set Up OEM anteriore	6			2		8
600	CBR600RR	2003-2004	HBK2588	Set Up RACE	1	1		1		3
600	CBR600RR	2003-2004	HBK2589	Set Up sopra parafango anteriore	1	1		1		3
600	CBR600RR	2005-2006	HBK2718	Set Up RACE	1	1		1		3
600	CBR600RR	2005-2006	HBK2719	Set Up sopra parafango anteriore	1	1		1		3
600	CBR600RR	2007-2017	HBK2761	Set Up sopra parafango anteriore	1	1		1		3
600	CBR600RR	2007-2017	HBK2762	Set Up RACE	1	1		1		3
600	CBR600RR ABS	2009-2017	HBK2831	Set Up OEM anteriore	4			1		5
600	FJS600 Silverwing ABS	2003-2010	HBK2769	Set Up OEM anteriore	3			2		5
600	NTV600-J Revere	1988-1991	HBK2323	Set Up OEM anteriore	1			1		2
600	VT600CN - CW Shadow	1992-2001	HBK2492	Set Up OEM anteriore	1					1
600	XL600 LMF Paris Dakar	1985-1986	HBK2537	Set Up OEM anteriore	1					1
600	XL600 RD -RF	1984-1986	HBK2549	Set Up OEM anteriore	1					1
600	XL600 VH - VK Transalp	1987-1989	HBK2386	Set Up OEM anteriore	1					1
600	XL600 VL - VT Transalp	1992-1996	HBK2390	Set Up OEM anteriore	1			1		2
600	XL600 VV - VX Transalp (Twin Disc)	1997-2003	HBK2870	Set Up RACE	1	1		1		3
600	XL600 XL650 VU - V7 Transalp	2001-2007	HBK2540	Set Up RACE	1	1		1		3
600	XL600 XL650 VU - V7 Transalp	2001-2007	HBK2539	Set Up OEM anteriore	1	1	1	1		4
600	XR600R	1991-1995	HBK2822	Set Up OEM anteriore	1			1		2
650	Bros 650	1988-1995	HBK2011	Set Up OEM anteriore	1			1		2
650	CB650 SC Nighthawk	1982-1985	HBK2086	Set Up OEM anteriore	1	2				3
650	CB650 Z	1981-1982	HBK2087	Set Up OEM anteriore	1	2				3
650	CB650F ABS	2014-2016	HBK2019	Set Up OEM anteriore	4			2		6
650	CB650F Non ABS	2015	HBK2090	Set Up RACE	1	1		1		3
650	CB650R Neo Sports Café (AK) ABS	2019-2020	HBK2046	Set Up OEM anteriore	5			3		8

CILIND.	MODELLO	ANNI	CODICE	CONFIGURAZIONE	ANT. SUP.	ANT. INF.	AGG.	POST.	FRIZ.	TOT. TUBI
650	CBR650F ABS	2014-2016	HBK2014	Set Up OEM anteriore	4			2		6
650	CBR650R ABS (AK)	2019-2021	HBK2033	Set Up OEM anteriore	4			3		7
650	CX650 Custom	1983	HBK2851	Set Up OEM anteriore	1					1
650	CX650 E	1983-1986	HBK2750	Set Up OEM anteriore	1	2		1		4
650	CX650 ED Eurosport	1983-1986	HBK2223	Set Up OEM anteriore	1	2		1		4
650	CX650 TD Turbo	1983-1985	HBK2227	Set Up OEM anteriore	1	2				3
650	FMX650	2004-2008	HBK2735	Set Up OEM anteriore	1			1		2
650	FX650 Vigor	1999-2003	HBK2364	Set Up OEM anteriore	1			1		2
650	GLE650 D2E Silverwing	1984-1986	HBK2275	Set Up OEM anteriore	1	2				3
650	NTV650 Deauville VW - V1	1998-2001	HBK2749	Set Up RACE	1	1		1		3
650	NTV650 P - V	1992-1996	HBK2326	Set Up OEM anteriore	1			1		2
650	NX650 J - X Dominator	1988-1995	HBK2330	Set Up OEM anteriore	1			1		2
650	NX650 J - X Dominator (Italian)	1995-2005	HBK2864	Set Up OEM anteriore	1			1		2
650	SLR650 V - W	1997-1999	HBK2363	Set Up OEM anteriore	1			1		2
650	XL650 RY Transalp	2000-2002	HBK2552	Set Up RACE	1	1		1		3
650	XR650 Enduro	1997-2006	HBK2559	Set Up OEM anteriore	1			1		2
650	XR650R UK	1997-2006	HBK2855	Set Up OEM anteriore	1			1		2
650	XR650R UK Supermoto'd By Customer	1997-2006	HBK2856	Set Up OEM anteriore	1			1		2
650	XR650R USA	2001-2007	HBK2857	Set Up OEM anteriore	1			1		2
650	XR650R USA Supermoto'd By Customer	2001-2007	HBK2858	Set Up OEM anteriore	1			1		2
650	XRV650 Africa Twin	1988-1989	HBK2871	Set Up OEM anteriore	1			1		2
650	XL650V Transalp	2000-2007	HBK0002	Set Up OEM anteriore	4			1		5
650	NTV650 Deauville V2 - V5	2002-2005	HBK2017	Set Up OEM anteriore						8
650	CBR650F ABS (AH-AJ)	2017-2018	HBK2027	Set Up OEM anteriore	4			2		6
650	CB650F AH-AJ ABS (RC97)	2017-2018	HBK2029	Set Up OEM anteriore	4			2		6
700	NC700 DCT-ABS	2012-2014	HBK2890	Set Up OEM anteriore	1	2	1	1		5
700	NTV700 Deauville ABS VA6 -VA13	2006-2013	HBK2738	Set Up OEM anteriore	7			2		9
700	VF700C Magna (Import)	1987-1988	HBK2436	Linea frizione					1	1
700	VF700C Magna (Import)	1987-1988	HBK2436	Set Up OEM anteriore	1	1	1			3
700	Transalp 700 ABS XL700V8 - XL700VAB	2008-2011	HBK2541	Set Up OEM anteriore	6			2		8
750	750 F2	1979	HBK2004	Set Up OEM anteriore	1	2		1		4
750	750 K2	1975	HBK2005	Set Up OEM anteriore	1	1				2
750	750 K2	1979	HBK2006	Set Up OEM anteriore	1	1				2
750	750 K6	1983	HBK2007	Set Up OEM anteriore		2				2
750	750/4 F1		HBK2009	Set Up OEM anteriore	1	1		1		3
750	CB750 Custom	1980-1985	HBK2103	Set Up OEM anteriore	1	2				3
750	CB750 F	1981	HBK2088	Set Up OEM anteriore	1	2		1		4
750	CB750 F1 Twin Disc	1977	HBK2089	Set Up OEM anteriore	1	2		1		4
750	CB750 F2 Twin Disc	1977	HBK2854	Set Up OEM anteriore	1	2		1		4
750	CB750 F2N - F2V	1992-1997	HBK2092	Set Up OEM anteriore	1	2		1		4
750	CB750 FB	1979-1983	HBK2094	Set Up OEM anteriore	1	2		1		4
750	CB750 K2 Single Disc	1972	HBK2095	Set Up OEM anteriore	1	1				2
750	CB750 K3 - K4 Single Disc	1973-1974	HBK2104	Set Up OEM anteriore	1	1				2
750	CB750 K6	1976-1976	HBK2720	Set Up OEM anteriore	1	1				2
750	CB750 K7	1978-1979	HBK2096	Set Up OEM anteriore	1	1				2
750	CB750 KZ	1978-1980	HBK2097	Set Up OEM anteriore	1	2		1		4

CILIND.	MODELLO	ANNI	CODICE	CONFIGURAZIONE	ANT. SUP.	ANT. INF.	AGG.	POST.	FRIZ.	TOT. TUBI
750	CBR750 Japanese Import	1987-1988	HBK2666	Set Up RACE	1	1		1		3
750	CBX750 F1	1984-1986	HBK2196	Set Up OEM anteriore	1	2		1		4
750	CBX750 FE	1984-1986	HBK2197	Set Up OEM anteriore	1	2		1		4
750	NC750 S	2014-2015	HBK2891	Set Up OEM anteriore	1			1		2
750	NC750 X ABS DCT	2014-2020	HBK2040	Set Up OEM anteriore	2			2		4
750	RVF750R R - S (RC45)	1994-1998	HBK2358	Set Up OEM anteriore	1	1	1	1		4
750	RVF750R RC45	1994-1998	HBC2358	Linea frizione					1	1
750	VF750	1983	HBC2444	Linea frizione					1	1
750	VF750 CH - CV	1987-1996	HBK2438	Set Up OEM anteriore	1					1
750	VF750 FD - FE	1983-1984	HBK2444	Set Up OEM anteriore	1	2		1		4
750	VF750 Sabre	1982-1984	HBK2447	Set Up OEM anteriore	1	2				3
750	VF750 S-C	1982-1984	HBK2448	Set Up OEM anteriore	1	2				3
750	VF750S	1982-1984	HBC2448	Linea frizione					1	1
750	VFR750 FG - FH	1986-1987	HBK2697	Set Up RACE	1	1		1		3
750	VFR750 FG - FH	1986-1987	HBK2464	Set Up OEM anteriore	1	2		1		4
750	VFR750 FJ - FK	1986-1987	HBC2464	Linea frizione					1	1
750	VFR750 FJ - FK	1988-1988	HBK2698	Set Up RACE	1	1		1		3
750	VFR750 FJ - FK	1988-1988	HBK2466	Set Up OEM anteriore	1	1	1	1		4
750	VFR750 FL - FP	1990-1993	HBC2696	Linea frizione					1	1
750	VFR750 FL - FP (RC24)	1989-1993	HBK2699	Set Up RACE	1	1		1		3
750	VFR750 FL - FP (RC24)	1989-1993	HBK2696	Set Up OEM anteriore	1	1	1	1		4
750	VFR750 FR - FV	1994-1997	HBC2635	Linea frizione					1	1
750	VFR750 FR - FV	1994-1997	HBK2635	Set Up RACE	1	1		1		3
750	VFR750 RJ - RK (RC30)	1988-1990	HBC2475	Linea frizione					1	1
750	VFR750 RJ - RK (RC30)	1988-1990	HBK2475	Set Up OEM anteriore	1	1		1		3
750	VT750 V-W Shadow	1997-1998	HBK2859	Set Up OEM anteriore	1					1
750	VT750C Shadow Spirit	2004-2008	HBK2688	Set Up OEM anteriore	1					1
750	XRV750 L - Y Africa Twin	1990-2003	HBK2823	Set Up RACE	1	1		1		3
750	XRV750 L - Y Africa Twin *See notes	1990-2003	HBK2828	Set Up OEM anteriore	1	1	1	1		4
750	X-ADV ABS	2017-2018	HBK0010	Set Up OEM anteriore	4			2		6
750	750 Supersport - DO NOT USE UNTIL MORE INFO IS ADDED	?	HBK2008	Set Up OEM anteriore	1	2		1		4
800	PC800 Pacific Ocean	1989-1998	HBC2667	Linea frizione					1	1
800	PC800 Pacific Ocean	1989-1998	HBK2667	Set Up OEM anteriore	1	2				3
800	VFR800F (FE-FK) ABS	2014-2020	HBK2045	Set Up OEM anteriore	4		1	2		7
800	VFR800 FIW - FI1	1998-2001	HBC2741	Linea frizione					1	1
800	VFR800 FIW - FI1	1998-2001	HBK2708	Set Up OEM anteriore	8			2		10
800	VFR800 V-TEC Linked Brakes - Non ABS	2002-2009	HBC2741	Set Up OEM anteriore	7			2		9
800	VFR800 V-TEC Linked Brakes & ABS	2002-2005	HBK2739	Set Up OEM anteriore	1		6	5		12
800	VFR800 V-TEC Linked Brakes & ABS	2006-2013	HBK2742	Set Up OEM anteriore	1		6	5		12
800	VFR800 V-TEC Non ABS & ABS	2002-2013	HBC2742	Linea frizione					1	1
800	VT800 Shadow Import	1988-1988	HBK2503	Set Up OEM anteriore	1			1		2
800	VFR800X Crossrunner ABS (XF-XH)	2015-2019	HBC2034	Linea frizione					1	1
800	VFR800X Crossrunner ABS (XF-XH)	2015-2019	HBK2034	Set Up OEM anteriore	4		1	2		7
900	CB900 F2		HBK2099	Set Up OEM anteriore	1	2		1		4
900	CB900 FA - FB	1980-1981	HBK2098	Set Up OEM anteriore	1	2		1		4

CILIND.	MODELLO	ANNI	CODICE	CONFIGURAZIONE	ANT. SUP.	ANT. INF.	AGG.	POST.	FRIZ.	TOT. TUBI
900	CB900 FC - FD	1982-1983	HBK2806	Set Up OEM anteriore	1	2		1		4
900	CB900 FZ	1979-1983	HBK2100	Set Up OEM anteriore	1	2		1		4
900	CB900F Hornet	1999-2007	HBK2591	Set Up RACE	1	1		1		3
900	CBR900 RRN - RRS Fireblade	1992-1995	HBK2162	Set Up RACE	1	1		1		3
900	CBR900 RRN - RRS Fireblade	1992-1995	HBK2161	Set Up OEM anteriore	1	1	1	1		4
900	CBR900 RRT - RRX Fireblade	1996-1999	HBK2172	Set Up RACE	1	1		1		3
900	CBR900 RRT - RRX Fireblade	1996-1999	HBK2173	Set Up OEM anteriore	1	1	1	1		4
929	CBR929 RRY - RR1 Fireblade	2000-2001	HBK2179	Set Up RACE	1	1		1		3
954	CBR954 RR2 - RR3 Fireblade	2002-2003	HBK2580	Set Up RACE	1	1		1		3
1000	CB1000 FP-FT Big One	1993-1996	HBC2026	Linea frizione					1	1
1000	CB1000 FP-FT Big One	1993-1996	HBK2020	Set Up OEM anteriore	1	2		1		4
1000	CB1000 USA Import	1983	HBK2025	Set Up OEM anteriore	1	2				3
1000	CB1000R	2008-2016	HBK2801	Set Up sopra parafango anteriore	1	1		2		4
1000	CB1000R	2008-2016	HBK2819	Set Up RACE	1	1		2		4
1000	CB1000R	2008-2016	HBK2800	Set Up OEM anteriore	1	1	1	2		5
1000	CB1000R (Non ABS & ABS)	2008-2017	HBC2817	Linea frizione					1	1
1000	CB1000R ABS	2009-2017	HBK2821	Set Up OEM anteriore	6			3		9
1000	CB1000R ABS	2020	HBFKK0031	Set Up OEM anteriore	1	1		1		3
1000	CBF1000	2006-2010	HBC2725	Linea frizione			1		1	2
1000	CBF1000	2006-2010	HBK2726	Set Up RACE	1	1		1		3
1000	CBF1000	2006-2010	HBK2725	Set Up OEM anteriore	1	1	1	1		4
1000	CBF1000 ABS A6 - AA	2006-2010	HBK2879	Set Up OEM anteriore	5			2		7
1000	CBF1000 ABS FAB -FAC	2011-2016	HBC2880	Linea frizione					1	1
1000	CBF1000 ABS FAB -FAC	2011-2016	HBK2880	Set Up OEM anteriore	6			2		8
1000	CBR1000 FH - FJ	1987-1988	HBK2102	Set Up RACE	1	1		1		3
1000	CBR1000 FH - FJ	1987-1988	HBK2101	Set Up OEM anteriore	1	1	1	1		4
1000	CBR1000 FH - FN	1987-1992	HBC2121	Linea frizione					1	1
1000	CBR1000 FK - FN	1989-1992	HBK2808	Set Up RACE	1	1		1		3
1000	CBR1000 FK - FN	1989-1992	HBK2807	Set Up OEM anteriore	1	1	1	1		4
1000	CBR1000F	1987-1992	HBC2807	Linea frizione					1	1
1000	CBR1000RR Fireblade	2004-2005	HBK2673	Set Up sopra parafango anteriore	1	1		1		3
1000	CBR1000RR Fireblade	2004-2005	HBK2689	Set Up RACE	1	1		1		3
1000	CBR1000RR Fireblade	2004-2007	HBC2689	Linea frizione					1	1
1000	CBR1000RR Fireblade	2006-2007	HBK2733	Set Up sopra parafango anteriore	1	1		1		3
1000	CBR1000RR Fireblade	2006-2007	HBK2734	Set Up RACE	1	1		1		3
1000	CBR1000RR Fireblade	2008-2016	HBK2802	Set Up RACE	1	1		1		3
1000	CBR1000RR Fireblade	2008-2016	HBK2803	Set Up sopra parafango anteriore	1	1		1		3
1000	CBR1000RR Fireblade ABS	2009-2016	HBK2829	Set Up OEM anteriore	4			2		6
1000	CBR1000RR Fireblade	2017-2018	HBFKK0012	Set Up RACE - SBK	4			1		5
1000	CBR1000RR Fireblade SP ABS	2017-2019	HBK2039	Set Up OEM anteriore	4			2		6
1000	CBR1000RR-R Fireblade SP (SC82) ABS	2020-2021	HBK2042	Set Up OEM anteriore	3			2		5
1000	CBX1000 A	1980-1980	HBK2810	Set Up OEM anteriore	1	2		1		4
1000	CBX1000 Pro-Link	1981-1982	HBK2180	Set Up OEM anteriore	1	2		1		4
1000	CBX1000 Z	1978-1979	HBK2811	Set Up OEM anteriore	1	2		1		4
1000	CRF1000L Africa Twin ABS	2016-2017	HBK2018	Set Up OEM anteriore	5			2		7
1000	CRF1000L Africa Twin ABS	2018-2019	HBK2038	Set Up OEM anteriore	4			2		6

CILIND.	MODELLO	ANNI	CODICE	CONFIGURAZIONE	ANT. SUP.	ANT. INF.	AGG.	POST.	FRIZ.	TOT. TUBI
1000	GL1000 Goldwing	1976	HBK2235	Set Up OEM anteriore	1	2		1		4
1000	GL1000 Goldwing	1976	HBK2236	Set Up OEM anteriore	1	2		1		4
1000	GL1000 KZ - K1 Goldwing	1979-1980	HBK2234	Set Up OEM anteriore	1	2		1		4
1000	VF1000 FE-FF	1984-1985	HBK2414	Set Up OEM anteriore	1	2		1		4
1000	VF1000 FII Bol Dor	1985-1986	HBK2415	Set Up OEM anteriore	1	2		1		4
1000	VF1000 RE - RG	1984-1986	HBK2417	Set Up RACE	1	1		1		3
1000	VF1000 RE - RG	1984-1986	HBK2416	Set Up OEM anteriore	1	2		1		4
1000	VF1000 RE - RG	1984-1988	HBC2416	Linea frizione					1	1
1000	VTR1000 Firestorm FV - F6	1997-2006	HBC2504	Linea frizione					1	1
1000	VTR1000 Firestorm FV - F6	1997-2006	HBK2505	Set Up RACE	1	1		1		3
1000	VTR1000 Firestorm FV - F6	1997-2006	HBK2506	Set Up sopra parafango anteriore	1	1		1		3
1000	VTR1000 Firestorm FV - F6	1997-2006	HBC2504	Set Up OEM anteriore	1	1	1	1		4
1000	VTR1000 SP1 - SP2	2000-2003	HBC2522	Linea frizione					1	1
1000	VTR1000 SP1 RC51	1999-2001	HBK2522	Set Up RACE	1	1		1		3
1000	VTR1000 SP1 RC51	1999-2001	HBK2523	Set Up sopra parafango anteriore	1	1		1		3
1000	VTR1000 SP2 RC51	2002-2007	HBK2526	Set Up RACE	1	1		1		3
1000	VTR1000 SP2 RC51	2002-2007	HBK2578	Set Up sopra parafango anteriore	1	1		1		3
1000	XL1000V Varadero	1998-2003	HBK2679	Set Up OEM anteriore	1					1
1000	XL1000V Varadero	2004-2008	HBK2678	Set Up OEM anteriore	1					1
1000	XL1000V Varadero ABS	2004-2006	HBK2680	Set Up OEM anteriore	1					1
1000	XL1000V Varadero ABS	2004-2006	HBK2681	Set Up OEM anteriore	1					1
1000	XL1000V Varadero ABS	2007-2008	HBK2774	Set Up OEM anteriore	1					1
1000	CBR1000RR Fireblade ABS	2017-2019	HBK2023	Set Up OEM anteriore	4			2		6
1000	CB1000R ABS AJ-AK	2018-2021	HBK2032	Set Up OEM anteriore	3			3		6
1100	CB1100F Bol D'or	1983-1984	HBK2051	Set Up OEM anteriore	1	2		1		4
1100	CB1100 RC - RD	1982-1984	HBK2028	Set Up OEM anteriore	1	2		1		4
1100	CB1100 X11	1999-2002	HBK2805	Set Up OEM anteriore	2	6		2		10
1100	CBR1100 XXV - XX6	1996-2007	HBK2709	Set Up OEM anteriore	8			2		10
1100	CBR1100 XXV-XX6	1996-2007	HBC2709	Linea frizione					1	1
1100	GL1100 A - B Goldwing	1980-1981	HBK2239	Set Up OEM anteriore	1	2		1		4
1100	GL1100 A Goldwing (Import)	1982	HBK2813	Set Up OEM anteriore	1	2		1		4
1100	GL1100 AD Aspencade	1983-1983	HBK2238	Set Up OEM anteriore	1	2				3
1100	GL1100 Goldwing DC Deluxe	1982-1982	HBK2241	Set Up OEM anteriore	1	2				3
1100	ST1100 AT - AY ABS/TCS	1996-2002	HBK2584	Set Up OEM anteriore	17					17
1100	ST1100 Non ABS	1990-2002	HBK2711	Set Up RACE	1	1	1	1		4
1100	ST1100 Non ABS	1992-1996	HBK2710	Set Up OEM anteriore						4
1100	ST1100 Pan European	1990-2002	HBC2378	Linea frizione					1	1
1100	ST1100 Pan European Non ABS	1990-2002	HBK2374	Set Up OEM anteriore	1	1	1	1		4
1100	ST1100 Pan European Non ABS + ABS	1990-2002	HBC2379	Linea frizione					1	1
1100	VF1100 Magna V65	1984-1988	HBC2573	Linea frizione					1	1
1100	VF1100 Magna V65 Import	1983-1986	HBK2573	Set Up OEM anteriore	1	2		1		4
1100	VT1100 Shadow Import	1987-1994	HBK2814	Linea frizione					1	1
1100	VT1100 Shadow Import	1987-1994	HBK2814	Set Up OEM anteriore	1					1
1200	GL1200 AD Aspencade	1983-1983	HBK2243	Set Up OEM anteriore	1	1	1	1		4
1200	GL1200 AD Aspencade Linked	1984-1987	HBK2244	Set Up OEM anteriore	1	1		1		3
1200	GL1200 AE - AH Aspencade	1984-1987	HBC2246	Linea frizione					1	1

CILIND.	MODELLO	ANNI	CODICE	CONFIGURAZIONE	ANT. SUP.	ANT. INF.	AGG.	POST.	FRIZ.	TOT. TUBI
1200	GL1200 AE Aspencade	1984-1984	HBK2245	Set Up OEM anteriore	1	1	1	1		4
1200	GL1200 AF - AG - AH Aspencade	1985-1988	HBK2246	Set Up OEM anteriore	1	1	1	1		4
1200	GL1200 DE Goldwing Deluxe	1984-1984	HBK2250	Set Up OEM anteriore	1	1		1		3
1200	GL1200 Interstate	1984	HBK2849	Set Up OEM anteriore	1	1	1	1		4
1200	VFR1200X Crossrunner ABS	2012-2020	HBK2044	Set Up OEM anteriore	5			2		7
1200	VFR1200F ABS	2010-2017	HBK2047	Set Up OEM anteriore	5			2		7
1200	VFR1200F ABS	2010-2017	HBK2047	Linea frizione					1	1
1300	CB1300	1995-2002	HBC2690	Linea frizione					1	1
1300	CB1300	1997-2002	HBK2690	Set Up OEM anteriore	1	1	1	1		4
1300	CB1300 SA	2005-2009	HBC2723	Linea frizione					1	1
1300	CB1300F	2003-2007	HBC2721	Linea frizione					1	1
1300	CB1300F	2003-2008	HBK2722	Set Up RACE	1	1		1		3
1300	CB1300F	2003-2008	HBK2721	Set Up OEM anteriore	1	2		1		4
1300	CB1300S	2003-2008	HBK2724	Set Up RACE	1	1		1		3
1300	CB1300S	2003-2008	HBK2723	Set Up OEM anteriore	1	2		1		4
1300	ST1300 Pan European ABS	2003-2013	HBK2740	Set Up OEM anteriore	15					15
1300	ST1300 Pan European Non ABS	2002-2006	HBK2030	Set Up OEM anteriore	1	8		5		14
1300	VTX1300	2004-2008	HBK2830	Set Up OEM anteriore	1			1		2
1300	VTX1300	2004-2008	HBK2684	Set Up OEM anteriore	1		1	1		3
1300	X4 1300	1997-2003	HBC2668	Linea frizione					1	1
1300	X4 1300	1997-2003	HBK2670	Set Up RACE	1	1		1		3
1300	X4 1300	1997-2003	HBK2668	Set Up OEM anteriore	1	1	1	1		4
1300	CB1300 ABS SA5-SA9	2005-2009	HBK2833	Set Up OEM anteriore	4			3		7
1500	GL1500 J - K - L Goldwing	1988-1991	HBK2252	Set Up OEM anteriore	1	1	1	1		4
1500	GL1500 J SEY Goldwing	1988-2000	HBK2631	Set Up OEM anteriore	1	1	1	1		4
1500	GL1500 J SEY Goldwing	1988-2000	HBC2631	Linea frizione					1	1
1500	Valkyrie F6C GL1500 CV - CW	1996-2003	HBC2395	Linea frizione					1	1
1500	Valkyrie F6C GL1500 CV - CW	1996-2003	HBK2396	Set Up RACE	1	1		1		3
1500	Valkyrie F6C GL1500 CV - CW	1996-2003	HBK2397	Set Up sopra parafango anteriore	1	1		1		3
1500	Valkyrie F6C GL1500 CV - CW	1996-2003	HBK2395	Set Up OEM anteriore	1	1	1	1		4
1800	VTX1800	2004-2008	HBF2686	Set Up OEM anteriore	1					1
HUSABERG										
550	550 FC	1999-2005	HBK2990	Set Up OEM anteriore	1			1		2
	400 - 650 Motorcross / Enduro	1999-2005	HBK2991	Set Up OEM anteriore	1			1		2
HUSQVARNA										
125	WR125	2002-2007	HBK3005	Set Up OEM anteriore	1			1		2
250	TC250	2002-2007	HBK3002	Set Up OEM anteriore	1			1		2
250	TC250	2010-2015	HBC3006	Linea frizione					1	1
250	TC250	2010-2015	HBK3009	Set Up OEM anteriore	1			1		2
250	TE250	2010-2015	HBC3006	Linea frizione					1	1
250	TE250	2010-2015	HBK3008	Set Up OEM anteriore	1			1		2
250	WR250	2002-2007	HBK3005	Set Up OEM anteriore	1			1		2
250	WR250	2010-2015	HBC3006	Linea frizione					1	1
250	WR250	2010-2015	HBK3010	Set Up OEM anteriore	1			1		2
300	WR300	2002-2007	HBK3005	Set Up OEM anteriore	1			1		2
310	TE310	2002-2007	HBK3004	Set Up OEM anteriore	1			1		2
310	TE310	2010-2015	HBC3006	Linea frizione					1	1

CILIND.	MODELLO	ANNI	CODICE	CONFIGURAZIONE	ANT. SUP.	ANT. INF.	AGG.	POST.	FRIZ.	TOT. TUBI
310	TE310	2010-2015	HBK3006	Set Up OEM anteriore	1			1		2
310	TE310R	2010-2015	HBK3007	Set Up OEM anteriore	1			1		2
350	WR350	2010-2015	HBC3006	Linea frizione					1	1
350	WR350	2010-2015	HBK3011	Set Up OEM anteriore	1			1		2
360	WR360	1998-2002	HBF3003	Set Up OEM anteriore	1					1
360	WR360	2003-2004	HBF3001	Set Up OEM anteriore	1					1
401	Svartpilen 401 ABS	2018-2019	HBK3013	Set Up OEM anteriore	1	1		2		4
449	TE449	2010-2015	HBC3006	Linea frizione					1	1
450	TC450	2002-2007	HBK3002	Set Up OEM anteriore	1			1		2
450	TE449	2010-2015	HBK3006	Set Up OEM anteriore	1			1		2
450	TE450	2002-2007	HBK3004	Set Up OEM anteriore	1			1		2
510	TE510	2002-2007	HBK3004	Set Up OEM anteriore	1			1		2
570	TC570	2002-2007	HBK3002	Set Up OEM anteriore	1			1		2
650	TR650 Terra	2012-2014	HBK3012	Set Up OEM anteriore	1			1		2
	Trial		HBF3000	Set Up OEM anteriore	1					1
HYOSUNG										
125	RX125	1995-2005	HBF3056	Set Up RACE	1					1
125	XRX125	2007-2011	HBF3058	Set Up OEM anteriore	1					1
250	GT250 EFI	2006-2008	HBK3057	Set Up OEM anteriore	1			1		2
650	GT650 Comet	2003-2005	HBK3050	Set Up OEM anteriore	1	2		1		4
650	GT650 R	2006-2007	HBK3051	Set Up RACE	1	1		1		3
650	GV650	2006-2015	HBK3055	Set Up RACE	1	1				2
650	GV650	2006-2015	HBK3054	Set Up OEM anteriore	1	2				3
	GT125R / GT250R	2006-2007	HBK3052	Set Up RACE	1	1		1		3
	GT125R / GT250R	2006-2007	HBK3053	Set Up OEM anteriore	1	2		1		4
ITALJET										
125	Dragster 125	1998-2003	HBK3950	Set Up OEM anteriore	1			1		2
KAWASAKI										
50	AR50 C1 - C10	1981-1997	HBF4042	Set Up OEM anteriore	1					1
65	KX65 Big Wheel	2001-2008	HBK4278	Set Up OEM anteriore	1			1		2
65	KX65 Small Wheel	2001-2008	HBK4736	Set Up OEM anteriore	1			1		2
80	AR80 C1 - C8	1983-1993	HBF4057	Set Up OEM anteriore	1					1
80	KX80	1997-2001	HBK4668	Set Up OEM anteriore	1			1		2
85	KX85	1997-2008	HBK4669	Set Up OEM anteriore	1			1		2
85	KX85	2012-2018	HBK4019	Set Up OEM anteriore				1		1
100	KX100	1997-2001	HBF4272	Set Up OEM anteriore	1					1
125	AR125 A1 - B8	1982-1994	HBF4023	Set Up OEM anteriore	1					1
125	KH125 K2 - K9	1982-1999	HBF4201	Set Up OEM anteriore	1					1
125	KH125 L1-EX	1983-1986	HBF4202	Set Up OEM anteriore	1					1
125	KMX125 A1 - A5 B1 - B12	1986-2002	HBK4251	Set Up OEM anteriore	1			1		2
125	KX125	1990-1993	HBK4274	Set Up OEM anteriore	1			1		2
125	KX125	1994-1996	HBK4671	Set Up OEM anteriore	1			1		2
125	KX125	2000-2002	HBK4666	Set Up OEM anteriore	1			1		2
125	KX125	2003-2008	HBK4006	Set Up OEM anteriore	1			1		2
200	KDX200 E1	1990-1994	HBK4189	Set Up OEM anteriore	1			1		2
200	KMX200 A2 - A3	1986-2002	HBK4252	Set Up OEM anteriore	1			1		2
200	VN2000	2004-2007	HBK4655	Set Up OEM anteriore	1	1	1	1		4
220	KDX220R A4 - A12	1997-2005	HBK4803	Set Up OEM anteriore	1			1		2

CILIND.	MODELLO	ANNI	CODICE	CONFIGURAZIONE	ANT. SUP.	ANT. INF.	AGG.	POST.	FRIZ.	TOT. TUBI
250	BJ250 Estrella	1996-1999	HBK4675	Set Up OEM anteriore	1			1		2
250	EL 250 D4 - D5	1993-1996	HBK4068	Set Up OEM anteriore	1					1
250	ER250 Z250T Scorpion B1 - B3	1983-1990	HBK4352	Set Up OEM anteriore	1					1
250	GPX250R	1988-1996	HBK4661	Set Up RACE	1			1		2
250	KH250 A1	1976-1980	HBK4210	Set Up OEM anteriore	1	1				2
250	KH250 B1 - B5	1976-1980	HBK4211	Set Up OEM anteriore	1	1				2
250	KH250 A1-B5 US Model high bars (Retains metal hard line from the caliper)	1976-1980	HBK4212	Set Up OEM anteriore	1	1				2
250	KH250 A1-B5 (Retains the metal hard line from the caliper)	1976-1980	HBK4209	Set Up OEM anteriore	1	1				2
250	KLR250 D1 - D16	1984-2001	HBK4238	Set Up OEM anteriore	1					1
250	KMX250	2007	HBK4711	Set Up OEM anteriore	1			1		2
250	KR1 KR250B2	1989-1992	HBK4267	Set Up OEM anteriore	1	2		1		4
250	KR1S KR250C2	1989-1992	HBK4269	Set Up OEM anteriore	1	2		1		4
250	KX250	1990-1992	HBK4670	Set Up OEM anteriore	1			1		2
250	KX250	1994-1996	HBK4672	Set Up OEM anteriore	1			1		2
250	KX250	1997-2000	HBK4275	Set Up OEM anteriore	1			1		2
250	KX250	2001-2003	HBK4652	Set Up OEM anteriore	1			1		2
250	KX250	2004-2006	HBK4679	Set Up OEM anteriore	1			1		2
250	KX250	2006-2008	HBK4700	Set Up OEM anteriore	1					1
250	KX250F	2004-2006	HBK4746	Set Up OEM anteriore	1			1		2
250	KX250F	2005-2008	HBK4732	Set Up OEM anteriore	1			1		2
250	KX250F	2009-2015	HBK4731	Set Up OEM anteriore	1			1		2
250	Ninja 250R	2008-2012	HBK4720	Set Up OEM anteriore	1			1		2
250	Z250 A1- A3 Twin	1979-1981	HBK4349	Set Up OEM anteriore	1			1		2
250	ZZR250 EX250 H1 - H2	1990-1992	HBK4580	Set Up OEM anteriore	1			1		2
252	EL 252 F2	1997-1999	HBK4072	Set Up OEM anteriore	1					1
300	KLX300	1999-2002	HBK4627	Set Up OEM anteriore	1			1		2
300	Ninja 300 ABS	2013-2017	HBK4005	Set Up OEM anteriore	2			2		4
300	Quad : KLF300	2003-2004	HBK4622	Set Up OEM anteriore	1	1	1			3
300	Ninja 300	2015-2018	HBK40003	Set Up RACE	1			1		2
305	GPZ305 EX305 A1 - B10	1983-1996	HBK4108	Set Up OEM anteriore	1	2				3
400	GPX400R Import	1987-1988	HBK4726	Set Up OEM anteriore	1	2				3
400	KH400 A1 - A4	1977-1980	HBK4217	Set Up OEM anteriore	1	1				2
400	KLX400	2004-2005	HBK4681	Set Up OEM anteriore	1			1		2
400	KLX400	2006-2007	HBK4706	Set Up OEM anteriore	1			1		2
400	KZ400	1975	HBK4281	Set Up OEM anteriore	1	1				2
400	Z400 FII C2	1984-1987	HBK4360	Set Up OEM anteriore	1	2				3
400	Z400 J1	1979	HBK4364	Set Up OEM anteriore	1	2				3
400	Z400 J2 - J3	1981-1983	HBK4365	Set Up OEM anteriore	1	2				3
400	Z400 S3		HBK4367	Set Up OEM anteriore	1					1
400	Z400 Twin	1980	HBK4368	Set Up OEM anteriore	1	1				2
400	Z400F ZR400 A1 - B1	1983-1985	HBK4369	Set Up OEM anteriore	1	2				3
400	ZX400 C2-C3	1985-1987	HBK4008	Set Up OEM anteriore	1	1	1			3
400	ZX400 G Import	1988	HBK4683	Set Up OEM anteriore	1	2		1		4
400	ZXR400 H1 - H2 Import	1989-1990	HBK4624	Set Up RACE	1	1		1		3
400	ZXR400 L1 - L9	1991-2003	HBK4532	Set Up RACE	1	1		1		3
400	ZXR400 L1 - L9	1991-2003	HBK4531	Set Up OEM anteriore	1	2		1		4
400	ZZR400	1990-2006	HBK4614	Set Up OEM anteriore	1	1		1		3

CILIND.	MODELLO	ANNI	CODICE	CONFIGURAZIONE	ANT. SUP.	ANT. INF.	AGG.	POST.	FRIZ.	TOT. TUBI
400	Ninja 400 ABS	2018-2019	HBK4015	Set Up OEM anteriore	1	1	1	1		4
400	Ninja 400	2018-2021	HBFKK0029	Set Up RACE						2
440	Z440 (Ltd Z440) A	1981-1983	HBK4377	Set Up OEM anteriore	1	1				2
440	Z440 C1 - C2	1980-1982	HBF4372	Set Up OEM anteriore	1					1
440	Z440 D4 - D6	1982-1985	HBF4376	Set Up OEM anteriore	1					1
440	Z440 H1 - H2	1982-1983	HBF4374	Set Up OEM anteriore	1					1
450	EN450 Z450 Ltd A1 - A5	1985-1990	HBF4384	Set Up OEM anteriore	1					1
450	KLX450R	2008-2015	HBK4722	Set Up OEM anteriore	1			1		2
450	KMX450	2007	HBK4710	Set Up OEM anteriore	1			1		2
450	KX450F	2006-2008	HBK4704	Set Up OEM anteriore	1			1		2
450	KX450F	2009-2015	HBK4750	Set Up OEM anteriore	1			1		2
450	KX450F	2019	HBC4018	Linea frizione					1	1
450	KX450F	2019	HBF4018	Set Up OEM anteriore	1					1
500	EN500 A1 - C2	1990-1997	HBF4075	Set Up OEM anteriore	1					1
500	ER-5 ER500 A1 - C1	1996-2006	HBF4081	Set Up OEM anteriore	1					1
500	GPZ500 S E9-E10 (Twin disc)	2002-2004	HBK4616	Set Up OEM anteriore	1	2		1		4
500	GPZ500 S EX500 A1 - A6	1987-1993	HBF4118	Set Up OEM anteriore	1					1
500	GPZ500 S EX500 D1 - D7	1994-2003	HBK4615	Set Up OEM anteriore	1			1		2
500	KH500	1976	HBK4221	Set Up OEM anteriore	1	1				2
500	KLE500 A1 - A3	1991-2002	HBK4226	Set Up OEM anteriore	1			1		2
500	KLE500 A3 - A7	2003-2007	HBK4759	Set Up OEM anteriore	1			1		2
500	KX500	1990-1993	HBK4276	Set Up OEM anteriore	1			1		2
500	KX500	1994-2001	HBK4643	Set Up OEM anteriore	1			1		2
500	KX500	2001-2004	HBK4667	Set Up OEM anteriore	1			1		2
500	Vulcan 500	1996-1997	HBF4729	Set Up OEM anteriore	1					1
500	Z500	1980-1983	HBK4391	Set Up OEM anteriore	1	2				3
550	550 ZR550 B1 - B6 Zephyr	1991-1998	HBK4427	Set Up OEM anteriore	1	2		1		4
550	GPZ550 Z550 A1 - A4	1983-1988	HBK4126	Set Up OEM anteriore	1	2	2	1		6
550	GPZ550 Z550 D1	1981-1981	HBK4130	Set Up OEM anteriore	1	2				3
550	GPZ550 Z550 H1 - H2 Unitrak	1982-1982	HBK4131	Set Up OEM anteriore	1	2		1		4
550	GT550 Z550 G1 - G9	1983-2001	HBK4165	Set Up OEM anteriore	1	2				3
550	Z550 A1	1980	HBK4392	Set Up OEM anteriore	1	2				3
550	Z550 A2 - A3	1981-1982	HBK4393	Set Up OEM anteriore	1	2				3
550	Z550 F ZR550 A1 - A2	1982-1987	HBK4395	Set Up OEM anteriore	1	2				3
550	Z550 Ltd C1 - C2	1980-1983	HBK4400	Set Up OEM anteriore	1	2				3
600	GPX600R C1 - C3	1988-1997	HBK4087	Set Up OEM anteriore	1	2		1		4
600	GPZ600R ZX600 A1 - A5	1985-1990	HBK4134	Set Up RACE	1	1	2	1		5
600	GPZ600R ZX600 A1 - A5	1985-1990	HBK4133	Set Up OEM anteriore	1	2	2	1		6
600	KLR600 A1 - B4	1984-1990	HBF4240	Set Up OEM anteriore	1					1
600	ZL600 B1 Eliminator	1995-1997	HBF4453	Set Up OEM anteriore	1					1
600	ZX6RR Ninja	2005-2006	HBK4676	Set Up RACE	1	1		1		3
600	ZX6R Ninja	2007-2008	HBK4709	Set Up RACE	1	1		1		3
600	ZX6R Ninja	2009-2012	HBK4734	Set Up RACE	1	1		1		3
600	ZX6R	2019	HBFKK0017	Set Up RACE - SUPERSTOCK	4			1		5
600	ZX6R Ninja ZX600 F1 - F3	1995-1997	HBK4484	Set Up RACE	1	1		1		3
600	ZX6R Ninja ZX600 F1 - F3	1995-1997	HBK4483	Set Up OEM anteriore	1	2		1		4
600	ZX6R Ninja ZX600 G1 - G2	1998-1999	HBK4490	Set Up RACE	1	1		1		3
600	ZX6R Ninja ZX600 G1 - G2	1998-1999	HBK4489	Set Up OEM anteriore	1	2		1		4

CILIND.	MODELLO	ANNI	CODICE	CONFIGURAZIONE	ANT. SUP.	ANT. INF.	AGG.	POST.	FRIZ.	TOT. TUBI
600	ZX6RR Ninja	2005-2006	HBK4677	Set Up sopra parafango anteriore	1	1		1		3
600	ZX6RR Ninja B1 - K1	2003-2004	HBK4698	Set Up sopra parafango anteriore	1	1		1		3
600	ZX6RR Ninja B1 - K1	2003-2004	HBK4699	Set Up RACE	1	1		1		3
600	ZX6RR Ninja 30th Anniversary Edition Radial Calipers	2003-2004	HBK4633	Set Up RACE						3
600	ZZR600 ZX600 D1 - E11	1990-2006	HBK4585	Set Up RACE	1	1		1		3
600	ZZR600 ZX600 D1 - E11	1990-2006	HBK4584	Set Up OEM anteriore	1	2		1		4
636	ZX6R Ninja	2013-2016	HBK4799	Set Up RACE	1	1		1		3
636	ZX6R Ninja	2013-2016	HBK4801	Set Up sopra parafango anteriore	1	1		1		3
636	ZX6R Ninja ABS	2013-2020	HBK4802	Set Up OEM anteriore	6			2		8
636	ZX6R Ninja ZX636 B1H-B2H	2003-2004	HBK4662	Set Up sopra parafango anteriore	1	1		1		3
636	ZX6R Ninja ZX636 B1H-B2H	2003-2004	HBK4663	Set Up RACE	1	1		1		3
636	ZX6R Ninja ZX600 J1 - J2 A1P (636)	2000-2002	HBK4496	Set Up RACE	1	1		1		3
636	ZX6R Ninja ZX600 J1 - J2 A1P (636)	2000-2002	HBK4495	Set Up OEM anteriore	1	1	1	1		4
636	ZX6R Ninja ZX636 C1H 636	2005-2006	HBK4718	Set Up sopra parafango anteriore	1	1		1		3
636	ZX6R Ninja ZX636 C1H 636	2005-2006	HBK4719	Set Up RACE	1	1		1		3
650	ER-6F	2006-2011	HBK4687	Set Up RACE	1	1		1		3
650	ER-6F	2006-2011	HBK4688	Set Up sopra parafango anteriore	1	1		1		3
650	ER-6F	2012-2016	HBK4771	Set Up RACE	1	1		1		3
650	ER-6F	2012-2016	HBK4772	Set Up sopra parafango anteriore	1	1		1		3
650	ER-6F ABS	2012-2016	HBK4760	Set Up OEM anteriore	5			2		7
650	ER-6N	2006-2011	HBK4689	Set Up RACE	1	1		1		3
650	ER-6N	2006-2011	HBK4690	Set Up sopra parafango anteriore	1	1		1		3
650	ER-6N	2012-2016	HBK4762	Set Up sopra parafango anteriore	1	1		1		3
650	ER-6N	2012-2013	HBK4763	Set Up RACE						3
650	ER-6N	2012-2016	HBK4773	Set Up RACE	1	1		1		3
650	ER-6N ABS	2006-2011	HBK4744	Set Up OEM anteriore	7					7
650	ER-6N ABS	2012-2016	HBK4776	Set Up OEM anteriore	1	2	2	2		7
650	KL650 B1 - B3 Tengai	1989-1991	HBK4222	Set Up OEM anteriore	1			1		2
650	KLE650 Versys	2007-2009	HBK4707	Set Up sopra parafango anteriore	1	1		1		3
650	KLE650 Versys	2007-2009	HBK4708	Set Up RACE	1	1		1		3
650	KLE650 Versys	2010-2014	HBK4774	Set Up RACE	1	1		1		3
650	KLE650 Versys	2010-2014	HBK4775	Set Up sopra parafango anteriore	1	1		1		3
650	KLE650 Versys ABS	2007-2009	HBK4755	Set Up OEM anteriore	5			2		7
650	KLE650 Versys ABS (FFF - FLF)	2015-2020	HBK4021	Set Up OEM anteriore	1	1	1	1		4
650	KLR650 A1 - A3 C1 - C8	1987-2002	HBK4244	Set Up OEM anteriore	1			1		2
650	KLX650 C1 - C2	1993-1996	HBK4247	Set Up OEM anteriore	1			1		2
650	KZ650 F2 - F4 Roadster	1981-1984	HBK4282	Set Up OEM anteriore	1	2				3
650	Ninja 650 ABS	2017-2020	HBK4009	Set Up OEM anteriore	3			1		4
650	W650 EJ650 A1 - C4 EU Wide Bar	1999-2006	HBK4314	Set Up OEM anteriore	1					1

CILIND.	MODELLO	ANNI	CODICE	CONFIGURAZIONE	ANT. SUP.	ANT. INF.	AGG.	POST.	FRIZ.	TOT. TUBI
650	W650 EJ650 A1 - C4 UK Low Bar	1999-2006	HBK4313	Set Up OEM anteriore	1					1
650	Z650 ABS	2017-2021	HBK4011	Set Up OEM anteriore	1	1	1	1		4
650	Z650 B1	1977	HBK4405	Set Up OEM anteriore	1	1				2
650	Z650 B2 - B3	1978-1979	HBK4406	Set Up OEM anteriore	1	2				3
650	Z650 C2 - C3	1978-1980	HBK4409	Set Up OEM anteriore	1	2		1		4
650	Z650 D2 - D3	1978-1980	HBK4411	Set Up OEM anteriore	1	2				3
650	Z650 F1	1980	HBK4412	Set Up OEM anteriore	1	2				3
650	Vulcan 650 S ABS (EN650BFF - EN650DJF)	2015-2018	HBK4017	Set Up OEM anteriore	1	1		2		4
700	Quad : KFX700	2000-2006	HBK4684	Set Up OEM anteriore	1	1				2
750	750 ZR750 C1 - D1 Zephyr	1991-1999	HBK4004	Set Up RACE	1	1		1		3
750	750 ZR750 C1 - D1 Zephyr	1991-1999	HBK4003	Set Up OEM anteriore	1	2		1		4
750	GPX750R F1 - F3	1987-1991	HBC4091	Linea frizione					1	1
750	GPX750R ZX750 F1 - F3	1987-1991	HBK4091	Set Up OEM anteriore	1	2		1		4
750	GPZ750 Turbo ZX750 E1 - E2	1983-1987	HBK4147	Set Up OEM anteriore	1	2	2	1		6
750	GPZ750 Z750 A1 - A5	1983-1988	HBK4152	Set Up OEM anteriore	1	2		1		4
750	GPZ750 Z750 R1	1982	HBK4156	Set Up OEM anteriore	1	2	2	1		6
750	GPZ750R R1 Non Anti-Dive	1981-1981	HBK4148	Set Up OEM anteriore	1	2		1		4
750	GT750 Z750 P1 - P5	1982-1990	HBK4179	Set Up OEM anteriore	1	2		1		4
750	GT750 Z750 P7 - P9	1991-1996	HBK4665	Set Up OEM anteriore	1	2		1		4
750	KH750 Single Disc Retaining Metal	1975	HBK4747	Set Up OEM anteriore	1	1				2
750	KZ750 E	1980	HBK4284	Set Up OEM anteriore	1	2		1		4
750	VN750	1995-2006	HBK4740	Set Up OEM anteriore	1	1		1		3
750	Z750	2004-2006	HBK4654	Set Up sopra parafango anteriore	1	1		1		3
750	Z750	2004-2006	HBK4664	Set Up RACE	1	1		1		3
750	Z750	2007-2012	HBK4713	Set Up sopra parafango anteriore	1	1		1		3
750	Z750	2007-2012	HBK4714	Set Up RACE	1	1		1		3
750	Z750 ABS	2007-2012	HBK4733	Set Up OEM anteriore	5			2		7
750	Z750 E		HBK4415	Set Up OEM anteriore	1	2				3
750	Z750 L2 - L4	1982-1984	HBK4416	Set Up OEM anteriore	1	2		1		4
750	Z750 Ltd Z750H2	1980-1981	HBK4423	Set Up OEM anteriore	1	2		1		4
750	Z750 Y1 Twin	1982-1983	HBK4424	Set Up OEM anteriore	1	1		1		3
750	Z750B Twin	1977	HBK4703	Set Up OEM anteriore	1	1		1		3
750	Z750S	2004-2006	HBK4692	Set Up RACE	1	1		1		3
750	Z750S	2004-2006	HBK4693	Set Up sopra parafango anteriore	1	1		1		3
750	ZR-7 ZR750 F1 - F5 ZR - 7S H3	1999-2003	HBK4606	Set Up RACE	1	1		1		3
750	ZR-7 ZR750 F1 - F5 ZR - 7S H3	1999-2003	HBK4456	Set Up OEM anteriore	1	2		1		4
750	ZX750		HBK4497	Set Up OEM anteriore	1	2	2	1		6
750	ZX750 GPA1		HBK4498	Set Up OEM anteriore	1	2	2	1		6
750	ZX7R Ninja ZX750 P1 - P7	1996-2003	HBC4501	Linea frizione					1	1
750	ZX7R Ninja ZX750 P1 - P7	1996-2003	HBK4502	Set Up RACE	1	1		1		3
750	ZX7R Ninja ZX750 P1 - P7	1996-2003	HBK4501	Set Up OEM anteriore	1	2		1		4
750	ZX7RR Ninja ZX750 N1	1996-2003	HBK4514	Set Up RACE	1	1		1		3
750	ZX7RR Ninja ZX750 N1	1996-2003	HBK4513	Set Up OEM anteriore	1	2		1		4
750	ZXR750 H1 - H2	1989-1990	HBC4545	Linea frizione					1	1

CILIND.	MODELLO	ANNI	CODICE	CONFIGURAZIONE	ANT. SUP.	ANT. INF.	AGG.	POST.	FRIZ.	TOT. TUBI
750	ZXR750 J1 - J2	1991-1995	HBC4547	Linea frizione					1	1
750	ZXR750 ZX750 H1 - H2	1989-1990	HBK4546	Set Up RACE	1	1		1		3
750	ZXR750 ZX750 H1 - H2	1989-1990	HBK4545	Set Up OEM anteriore	1	2		1		4
750	ZXR750 ZX750 J1 - J2	1991-1992	HBK4548	Set Up RACE	1	1		1		3
750	ZXR750 ZX750 J1 - J2	1991-1992	HBK4547	Set Up OEM anteriore	1	2		1		4
750	ZXR750 ZX750 K1 - L1	1991-1996	HBK4552	Set Up RACE	1	1		1		3
750	ZXR750 ZX750 K1 - L1	1991-1996	HBK4551	Set Up OEM anteriore	1	2		1		4
750	ZXR750R ZX750 M1 - M2	1992-1994	HBK4730	Set Up RACE	1	1		1		3
750	ZXR750R ZX750 M1 - M2	1992-1994	HBK4558	Set Up OEM anteriore	1	2		1		4
750	Z750R	2011-2012	HBK4013	Set Up sopra parafango anteriore	1	1		1		3
750	Z750R	2011-2012	HBK4014	Set Up RACE	1	1		1		3
800	VN800 A1 - A3 B1 - B6 Classic E1 - E2 Drifter	1995-2006	HBK4301	Set Up OEM anteriore	1					1
800	W800	2011-2016	HBK4753	Set Up OEM anteriore	1					1
800	Z800 ABS	2013-2016	HBK4007	Set Up OEM anteriore	4			1		5
800	Z800 Non ABS	2013-2016	HBK4766	Set Up sopra parafango anteriore	1	1		1		3
800	Z800 Non ABS	2013-2016	HBK4767	Set Up RACE	1	1		1		3
900	GPZ900R A1 - A8	1984-1996	HBC4157	Linea frizione					1	1
900	GPZ900R ZX900 A1 - A6	1984-1989	HBK4157	Set Up OEM anteriore	1	2	2	1		6
900	GPZ900R ZX900 A1-6 US SPEC	1984-1989	HBK4158	Set Up OEM anteriore	1	2	2	1		6
900	GPZ900R ZX900 A7 - A8	1990-1992	HBK4686	Set Up RACE	1	1		1		3
900	GPZ900R ZX900 A7 - A8	1990-1992	HBK4685	Set Up OEM anteriore	1	2		1		4
900	VN900 Classic	2006-2010	HBK4691	Set Up OEM anteriore	1			1		2
900	Z900	1978	HBK4426	Set Up OEM anteriore	1	2				3
900	Z900 ABS	2017-2019	HBK4010	Set Up OEM anteriore	3			3		6
900	Z900 ABS	2017-2020	HBFKK0025	Set Up OEM anteriore						6
900	Z900 ABS	2021	HBFKK0030							
900	Z900 ABS	2020-2022	HBK4026	Set Up OEM anteriore	1	2		4		7
900	Z900 Replaces Metal Pipe	1976	HBK4765	Set Up RACE	1			1		2
900	Z900 Retains Metal Pipe	1976	HBK4764	Set Up RACE	1			1		2
900	ZX9R B1 - B4	1994-1997	HBC4519	Linea frizione					1	1
900	ZX9R C1 - C2	1998-1999	HBC4523	Linea frizione					1	1
900	ZX9R E1 - E2	2000-2001	HBC4528	Linea frizione					1	1
900	ZX9R Ninja ZX900 B1 - B2	1994-1995	HBK4751	Set Up RACE	1	1		1		3
900	ZX9R Ninja ZX900 B1 - B2	1994-1995	HBK4752	Set Up OEM anteriore	1	2		1		4
900	ZX9R Ninja ZX900 B3 - B4	1996-1997	HBK4520	Set Up RACE	1	1		1		3
900	ZX9R Ninja ZX900 B3 - B4	1996-1997	HBK4519	Set Up OEM anteriore	1	2		1		4
900	ZX9R Ninja ZX900 C1 - C2	1998-1999	HBK4524	Set Up RACE	1	1		1		3
900	ZX9R Ninja ZX900 C1 - C2	1998-1999	HBK4523	Set Up OEM anteriore	1	2		1		4
900	ZX9R Ninja ZX900 E1 - E2	2000-2001	HBK4528	Set Up RACE	1	1		1		3
900	ZX9R Ninja ZX900 E1 - E2	2000-2001	HBK4678	Set Up OEM anteriore	1	1	1	1		4
900	ZX9R Ninja ZX900 F1P - F2P	2002-2005	HBK4682	Set Up RACE	1	1		1		3
900	Z900RS Cafe ABS (EJF-EKF)	2018-2021	HBK4016	Set Up OEM anteriore	4			2		6
900	Z900RS ABS (CJF / CKF)	2018-2021	HBK4020	Set Up OEM anteriore	4			2		6
900	Z1R	1978	HBK4334	Set Up OEM anteriore	2			1		3
900	Z1R	1978	HBK4348	Set Up OEM anteriore	1			1		2
1000	GPZ1000RX A1 - A3	1985-1989	HBC4096	Linea frizione					1	1
1000	GPZ1000RX ZX1000 A1 - A3	1985-1988	HBK4096	Set Up OEM anteriore	1	2	2	1		6

CILIND.	MODELLO	ANNI	CODICE	CONFIGURAZIONE	ANT. SUP.	ANT. INF.	AGG.	POST.	FRIZ.	TOT. TUBI
1000	GTR1000 A1-A14	1986-1999	HBK4188	Linea frizione					1	1
1000	GTR1000 ZG1000 A1-A4	1986-1989	HBK4188	Set Up OEM anteriore	1	2		1		4
1000	GTR1000 ZG1000 A5-A14	1990-1999	HBK4717	Set Up OEM anteriore	1	2		1		4
1000	KLV1000	2004-2006	HBK4674	Set Up RACE	1	1		1		3
1000	KLV1000	2004-2006	HBK4673	Set Up OEM anteriore	1	1	1	1		4
1000	KLZ1000 Versys ABS	2012-2018	HBK4001	Set Up OEM anteriore	4			1		5
1000	KZ1000 D1	1978	HBK4279	Set Up OEM anteriore	1			1		2
1000	Ninja H2 ABS	2015-2019	HBK4022	Set Up OEM anteriore	5			3		8
1000	Ninja H2 ABS	2015-2019	HBK4022	Linea frizione					2	2
1000	Ninja 1000SX ABS	2020-2022	HBK4025	Set Up OEM anteriore	4			1		5
1000	RX1000	1985-1989	HBK4712	Set Up OEM anteriore	1	2	2			5
1000	Z1000	2003-2006	HBK4635	Set Up sopra parafango anteriore	1	1		1		3
1000	Z1000	2003-2006	HBK4636	Set Up RACE	1	1		1		3
1000	Z1000	2007-2009	HBK4715	Set Up sopra parafango anteriore	1	1		1		3
1000	Z1000	2007-2009	HBK4716	Set Up RACE	1	1		1		3
1000	Z1000	2010-2013	HBK4742	Set Up RACE	1	1		1		3
1000	Z1000	2010-2013	HBK4743	Set Up sopra parafango anteriore	1	1		1		3
1000	Z1000	2014-2016	HBK4639	Set Up RACE	1	1		1		3
1000	Z1000 A1	1977	HBK4317	Set Up OEM anteriore	1	2		1		4
1000	Z1000 A2	1978	HBK4318	Set Up OEM anteriore	1	2		1		4
1000	Z1000 A3/A4	1979-1980	HBK4757	Set Up OEM anteriore	1	2		1		4
1000	Z1000 ABS	2010-2013	HBR4741	Set Up OEM anteriore						0
1000	Z1000 ABS	2014-2019	HBK4739	Set Up OEM anteriore	4			1		5
1000	Z1000 CSR KZ1000M	1980-1990	HBK4041	Set Up OEM anteriore	1	2		1		4
1000	Z1000 H	1980-1981	HBK4320	Set Up OEM anteriore	1	2		1		4
1000	Z1000 J	1977	HBK4321	Set Up OEM anteriore	1	2		1		4
1000	Z1000 J1	1981	HBK4322	Set Up OEM anteriore	1	2		1		4
1000	Z1000 J2 - J3	1981-1984	HBK4323	Set Up OEM anteriore	1	2		1		4
1000	Z1000 Ltd	1979	HBK4761	Set Up OEM anteriore	1	2		1		4
1000	Z1000 Ltd Z1000K1	1981-1983	HBK4326	Set Up OEM anteriore	1	2		1		4
1000	Z1000 MKII	1978-1981	HBK4329	Set Up OEM anteriore	1	2		1		4
1000	Z1000 R2 Eddie Lawson Replica	1983-1984	HBK4330	Set Up OEM anteriore	1	2		1		4
1000	Z1000 ST E1	1979	HBK4333	Set Up OEM anteriore	1	2		1		4
1000	Z1000 ST E2	1980	HBK4332	Set Up OEM anteriore	1	2		1		4
1000	Z1000 SX	2011-2015	HBK4754	Set Up RACE	1	1		1		3
1000	Z1000 SX ABS	2011-2013	HBK4770	Set Up OEM anteriore	4			1		5
1000	Z1000 SX (Ninja) ABS	2014-2019	HBK4024	Set Up OEM anteriore	4			1		5
1000	ZL1000 A1 Eliminator	1987-1990	HBK4448	Set Up OEM anteriore	1	2		1		4
1000	ZX10 B1 - B3	1988-1991	HBK4470	Linea frizione					1	1
1000	ZX10 ZX1000 B1 - B3	1988-1991	HBK4725	Set Up RACE	1	1		1		3
1000	ZX10 ZX1000 B1 - B3	1988-1991	HBK4470	Set Up OEM anteriore	1	2		1		4
1000	ZX10R ABS	2011-2015	HBK4758	Set Up OEM anteriore	4			2		6
1000	ZX10R ABS	2016-2018	HBK4756	Set Up OEM anteriore	4			2		6
1000	ZX10R Ninja	2004-2005	HBK4651	Set Up sopra parafango anteriore	1	1		1		3
1000	ZX10R Ninja	2004-2005	HBK4653	Set Up RACE	1	1		1		3
1000	ZX10R Ninja	2006-2007	HBK4694	Set Up RACE	1	1		1		3

CILIND.	MODELLO	ANNI	CODICE	CONFIGURAZIONE	ANT. SUP.	ANT. INF.	AGG.	POST.	FRIZ.	TOT. TUBI
1000	ZX10R Ninja	2006-2007	HBK4695	Set Up sopra parafango anteriore	1	1		1		3
1000	ZX10R Ninja	2008-2010	HBK4723	Set Up sopra parafango anteriore	1	1		1		3
1000	ZX10R Ninja	2008-2010	HBK4724	Set Up RACE	1	1		1		3
1000	ZX10R Ninja	2011-2015	HBK4749	Set Up RACE	1	1		1		3
1000	ZX10R Ninja Supersport	2016-2021	HBFKK0001	Set Up RACE	4			1		5
1000	ZX10R Superbike version con Staubli (Staubli non compreso nel kit) solo anteriore	2021	HBFKK0027	Set Up RACE						3
1100	1100 ZR1100 A1 - B1 Zephyr	1992-1997	HBC4436	Linea frizione					1	1
1100	1100 ZR1100 A1 - B1 Zephyr	1992-1997	HBK4436	Set Up OEM anteriore	1	2		1		4
1100	GPZ1100 Z1100 A1 - A2	1983-1984	HBK4099	Set Up OEM anteriore	1	2	2	1		6
1100	GPZ1100 Z1100 A3 Non ABS	1985-1985	HBK4101	Set Up OEM anteriore	1	2		1		4
1100	GPZ1100 Z1100 B1 - B2	1981-1982	HBK4102	Set Up OEM anteriore	1	2		1		4
1100	GPZ1100S ZX1100 E1 - E2 Non ABS	1995-1999	HBK4104	Set Up OEM anteriore	1	2		1		4
1100	Z1100 A1 - A4	1981-1983	HBK4335	Set Up OEM anteriore	1	2		1		4
1100	Z1100 R1 Eddie Lawson Replica	1984-1986	HBK4339	Set Up OEM anteriore	1	2		1		4
1100	ZL1100 Custom	1987	HBK4452	Set Up OEM anteriore	1	2				3
1100	ZL1100 Custom		HBC4452	Linea frizione					1	1
1100	ZRX1100 C1 - C4	1997-2001	HBK4460	Set Up RACE	1	1		1		3
1100	ZRX1100 C1 - C4	1997-2001	HBK4459	Set Up OEM anteriore	1	2		1		4
1100	ZRX1100 C1 - C4	1997-2002	HBC4460	Linea frizione					1	1
1100	ZX1100 A1	1982-1983	HBK4474	Set Up OEM anteriore	1	2	2	1		6
1100	ZX1100 A2	1984-1989	HBK4475	Set Up OEM anteriore	1	2	2	1		6
1100	ZX1100 C1	1990-1995	HBK4476	Set Up OEM anteriore	1	2		1		4
1100	ZZR1100 ZX1100 C1 - C3	1990-1992	HBK4561	Set Up RACE	1	1		1		3
1100	ZZR1100 ZX1100 C1 - C3	1990-1992	HBK4560	Set Up OEM anteriore	1	2		1		4
1100	ZZR1100 ZX1100 C1 - D9	1990-2001	HBC4560	Linea frizione					1	1
1100	ZZR1100 ZX1100 D1 - D9	1992-2001	HBK4567	Set Up RACE	1	1		1		3
1100	ZZR1100 ZX1100 D1 - D9	1992-2001	HBK4566	Set Up OEM anteriore	1	2		1		4
1200	ZRX1200 A1 - A3P	2001-2005	HBK4660	Set Up RACE	1	1		1		3
1200	ZRX1200 A1 - A3P	2001-2005	HBK4659	Set Up OEM anteriore	1	2		1		4
1200	ZRX1200R A1 - A3P	2001-2006	HBC4461	Linea frizione					1	1
1200	ZRX1200R A1 - A3P	2001-2006	HBK4645	Set Up RACE	1	1		1		3
1200	ZRX1200R A1 - A3P	2001-2006	HBK4644	Set Up OEM anteriore	1	2		1		4
1200	ZRX1200S B1 - B3P	2001-2005	HBK4610	Set Up RACE	1	1		1		3
1200	ZRX1200S B1 - B3P	2001-2005	HBK4611	Set Up OEM anteriore	1	2		1		4
1200	ZX12R Ninja ZX1200 A1 - A2 B1H - B2H C1H - C2H	1999-2003	HBK4478	Set Up RACE	1	1		1		3
1200	ZX12R Ninja ZX1200 A1 - A2 B1H - B2H C1H - C2H	1999-2003	HBK4477	Set Up OEM anteriore	1	1	1	1		4
1200	ZX12R Ninja ZX1200 R	2003-2006	HBK4637	Set Up RACE	1	1		1		3
1200	ZX12R Ninja ZX1200 R	2003-2006	HBK4638	Set Up sopra parafango anteriore	1	1		1		3
1200	ZZR1200 ZX1200	2002-2006	HBC4631	Linea frizione					1	1
1200	ZZR1200 ZX1200	2002-2006	HBK4632	Set Up RACE	1	1		1		3
1200	ZZR1200 ZX1200	2002-2006	HBK4631	Set Up OEM anteriore	1	2		1		4
1300	KZ1300 B2 US Import	1980	HBK4280	Set Up OEM anteriore	1	2		1		4
1300	Z1300 A1 - A2	1979-1980	HBK4342	Set Up OEM anteriore	1	2		1		4

CILIND.	MODELLO	ANNI	CODICE	CONFIGURAZIONE	ANT. SUP.	ANT. INF.	AGG.	POST.	FRIZ.	TOT. TUBI
1300	Z1300 A3 - A5	1981-1984	HBK4344	Set Up OEM anteriore	1	2		1		4
1300	ZG1300 A1 - A3	1987-1990	HBK4442	Set Up OEM anteriore	1	2		1		4
1400	ZZR1400	2006-2017	HBC4696	Linea frizione					1	1
1400	ZZR1400 ZX14	2006-2014	HBK4697	Set Up sopra parafango anteriore	1	1		1		3
1400	ZZR1400 ZX14	2006-2014	HBK4702	Set Up RACE	1	1		1		3
1400	ZZR1400 ZX14 ABS	2006-2017	HBK4745	Set Up OEM anteriore	7			2		9
1441	ZZR1400 ZX14 ABS Performance Sport	2016-2018	HBK4012	Set Up OEM anteriore	7			2		9
1500	VN1500 B2 - B6 Vulcan C1 - C2 Classic	1988-1996	HBF4283	Set Up OEM anteriore	1					1
1500	VN1500 Classic D1-D2 E1 J1-J2 Drifter	1996-1999	HBC4293	Linea frizione					1	1
1500	VN1500 Classic D1-D2 E1 J1-J2 Drifter	1999-2003	HBC4300	Linea frizione					1	1
1500	VN1500 D1 - D2 E1 Classic J1 - J2 Drifter	1996-1999	HBK4293	Set Up OEM anteriore	1			1		2
1500	VN1500 E2 Classic G1 - G2 L1 - L2 Nomad	1998-1999	HBK4290	Set Up OEM anteriore	1	1		1		3
1500	VN1500 Vulcan	1996-2003	HBK4300	Set Up OEM anteriore	1	2		1		4
1600	VN1600 Classic	2004-2007	HBK4657	Set Up OEM anteriore	1	1	1	1		4
1600	VN1600 Classic Tourer	2004-2007	HBC4658	Linea frizione					1	1
1600	VN1600 Classic Tourer Fi	2004-2007	HBK4658	Set Up OEM anteriore	1	1	1	1		4
1600	VN1600 Mean Streak	2004-2007	HBK4680	Set Up RACE	1	1		1		3
1600	VN1600 Mean Streak	2004-2007	HBK4656	Set Up OEM anteriore	1	2		1		4
1600	VN1600 Meanstreak	2004-2007	HBC4656	Linea frizione					1	1
	Z1 Z1A Z1B	1973-1975	HBK4319	Set Up OEM anteriore	1	2				3
	KH100 G5 - G8	1984-1993	HBF4737	Set Up OEM anteriore	1					1
	KH100 G5 - G8	1984-1993	HBK4190	Set Up OEM anteriore	1	1				2
	Z1A (Single Disc)	1973-1975	HBK4316	Set Up OEM anteriore	1	1		1		3
	ZRX400 E1-E2	1994-1995	HBK4462	Set Up OEM anteriore	1	2		1		4
	ZR250 Balius	1991-1996	HBK4581	Set Up OEM anteriore	1			1		2
	H1B - H1F	1972-1975	HBK4727	Set Up OEM anteriore	1	1				2
	KH100 G1 - G4	1980-1983	HBK4728	Set Up OEM anteriore	1	1				2
KEEWAY										
250	Landcruiser 250	2004-2005	HBK4850	Set Up OEM anteriore	1			1		2
KSR										
50	50	2004-2005	HBK4800	Set Up OEM anteriore	1			1		2
110	110	2004-2005	HBK4800	Set Up OEM anteriore	1			1		2
KTM										
50	SX50 - Magura	2012-2020	HBK3019	Set Up OEM anteriore	1			1		2
65	65 SX	2004-2012	HBK5026	Set Up OEM anteriore	1			1		2
65	65 SX	2014-2015	HBF5050	Set Up OEM anteriore	1					1
85	85 Big Wheel	2005-2006	HBK5020	Set Up OEM anteriore	1			1		2
85	85 SX	2003	HBK5027	Set Up OEM anteriore	1			1		2
85	85 SX	2004-2008	HBF5025	Set Up OEM anteriore	1					1
85	85 SX	2013-2015	HBK5041	Set Up OEM anteriore	1			1		2
125	125 Duke	2011-2012	HBK5030	Set Up OEM anteriore	1			1		2
125	125 EXC	2000-2005	HBK5012	Set Up OEM anteriore	1			1		2
125	125 SX	2000-2005	HBK5010	Set Up OEM anteriore	1			1		2
125	125 SX	2000-2008	HBK5029	Set Up OEM anteriore	1			1		2

CILIND.	MODELLO	ANNI	CODICE	CONFIGURAZIONE	ANT. SUP.	ANT. INF.	AGG.	POST.	FRIZ.	TOT. TUBI
125	125 SX - SX-F	2009-2015	HBC5000	Linea frizione					1	1
125	125 SX - SX-F	2009-2015	HBK5000	Set Up OEM anteriore	1			1		2
125	EXC	2004-2009	HBK5031	Set Up OEM anteriore	1			1		2
125	EXC	2013-2015	HBK5001	Set Up OEM anteriore	1					1
150	150 SX	2000-2008	HBK5029	Set Up OEM anteriore	1			1		2
150	EXC	2004-2009	HBK5031	Set Up OEM anteriore	1			1		2
150	EXC	2013-2015	HBK5001	Set Up OEM anteriore	1					1
200	200 SX	2000-2005	HBK5011	Set Up OEM anteriore	1			1		2
200	200 SX	2000-2008	HBK5029	Set Up OEM anteriore	1			1		2
200	EXC	2004-2009	HBK5031	Set Up OEM anteriore	1			1		2
200	EXC	2013-2015	HBK5001	Set Up OEM anteriore	1					1
250	250 EXC	2000-2005	HBK5013	Set Up OEM anteriore	1			1		2
250	250 EXC Racing	2000-2005	HBK5004	Set Up OEM anteriore	1			1		2
250	250 SX	2000-2005	HBK5007	Set Up OEM anteriore	1			1		2
250	250 SX	2000-2008	HBK5029	Set Up OEM anteriore	1			1		2
250	250 SX - SX-F	2009-2015	HBC5000	Linea frizione					1	1
250	250 SX - SX-F	2009-2015	HBK5000	Set Up OEM anteriore	1			1		2
250	250 SX-F	2016	HBC5003	Linea frizione					1	1
250	EXC	2004-2009	HBK5031	Set Up OEM anteriore	1			1		2
250	EXC	2013-2015	HBK5001	Set Up OEM anteriore	1					1
250	Freeride 250 & 350	2012-2016	HBC5023	Linea frizione					1	1
250	Freeride 250 & 350	2012-2016	HBK5023	Set Up OEM anteriore	1			1		2
250	XC-F250 & XCF-W250	2009-2016	HBC5028	Linea frizione					1	1
300	300 EXC	1998-2006	HBK5033	Set Up OEM anteriore	1					1
350	300 SX	2000-2008	HBK5029	Set Up OEM anteriore	1			1		2
350	350 EXC	2007-2011	HBK5037	Set Up OEM anteriore	1					1
350	350 SX - SX-F	2009-2015	HBC5000	Linea frizione					1	1
350	350 SX - SX-F	2009-2015	HBK5000	Set Up OEM anteriore	1			1		2
350	350 XCF	2007-2013	HBK5039	Set Up OEM anteriore	1			1		2
350	EXC	2004-2009	HBK5031	Set Up OEM anteriore	1			1		2
350	EXC	2013-2015	HBK5001	Set Up OEM anteriore	1					1
380	380 SX Supermoto	1999-2006	HBK5021	Set Up OEM anteriore	1					1
390	RC 390 ABS	2014-2018	HBK5390	Set Up OEM anteriore	1	1	1	1		4
400	400 EXC Racing	2000-2005	HBK5005	Set Up OEM anteriore	1			1		2
400	400 SX	2000-2008	HBK5029	Set Up OEM anteriore	1			1		2
400	EXC	2004-2009	HBK5031	Set Up OEM anteriore	1			1		2
400	EXC	2013-2015	HBK5001	Set Up OEM anteriore	1					1
450	450 EXC Racing	2000-2005	HBK5006	Set Up OEM anteriore	1			1		2
450	450 EXC SX125	2003-2007	HBC5005	Linea frizione					1	1
450	450 SX	2000-2005	HBK5008	Set Up OEM anteriore	1			1		2
450	450 SX	2000-2008	HBK5029	Set Up OEM anteriore	1			1		2
450	450 SX - SX-F	2009-2015	HBC5000	Linea frizione					1	1
450	450 SX - SX-F	2009-2015	HBK5000	Set Up OEM anteriore	1			1		2
450	EXC	2004-2009	HBK5031	Set Up OEM anteriore	1			1		2
450	EXC	2013-2015	HBK5001	Set Up OEM anteriore	1					1
450	450 SMR	2012-2014	HBC5044	Linea frizione					1	1
450	450 SMR	2012-2014	HBK5044	Set Up OEM anteriore	1			1		2
525	525 EXC	2003-2007	HBC5022	Linea frizione					1	1
525	525 EXC	2003-2007	HBK5022	Set Up OEM anteriore	1			1		2

CILIND.	MODELLO	ANNI	CODICE	CONFIGURAZIONE	ANT. SUP.	ANT. INF.	AGG.	POST.	FRIZ.	TOT. TUBI
525	525 SX	2003-2006	HBK5009	Set Up OEM anteriore	1			1		2
530	530 SX	2000-2008	HBK5029	Set Up OEM anteriore	1			1		2
530	EXC	2004-2009	HBK5031	Set Up OEM anteriore	1			1		2
530	EXC	2013-2015	HBF5001	Set Up OEM anteriore	1					1
620	620 Duke	1994-1998	HBF5036	Set Up OEM anteriore	1					1
625	625 SMC	2002-2006	HBK5024	Set Up OEM anteriore	1			1		2
640	640 Duke	1995-2003	HBK5019	Set Up OEM anteriore	1			1		2
640	640 Duke	2003-2005	HBK5017	Set Up OEM anteriore	1			1		2
640	640 LC4	2000-2005	HBK5015	Set Up OEM anteriore	1			1		2
640	640 LC4 Adventurer	2000-2005	HBK5016	Set Up sopra parafango anteriore	1	1		1		3
660	660 SMC	2003-2006	HBK5018	Set Up OEM anteriore	1			1		2
690	690 SMC R ABS	2014-2016	HBK5051	Set Up OEM anteriore	2			2		4
690	690 Duke ABS	2015-2017	HBK5045	Set Up OEM anteriore	1	1	1	1		4
690	690 SMC	2008-2010	HBK5028	Set Up OEM anteriore	1			1		2
790	790 Duke ABS	2018-2019	HBK5046	Set Up OEM anteriore	4			2		6
950	950 Adventurer	2000-2005	HBK5002	Set Up sopra parafango anteriore	1	1		1		3
990	990 Adventurer	2008-2009	HBK5032	Set Up OEM anteriore	1	1	1			3
990	990 Duke	2000-2005	HBK5014	Set Up OEM anteriore	1			1		2
990	990 R Super Duke	2011-2012	HBK5043	Set Up RACE	1	1				2
990	990 SMR / SMT	2009-2011	HBK5038	Set Up RACE	1	1		1		3
990	990 SMR / SMT	2009-2011	HBK5042	Set Up OEM anteriore	1	2	1	1		5
990	990 Super Duke	2004-2006	HBC5035	Linea frizione					1	1
990	990 Super Duke	2004-2006	HBK5035	Set Up OEM anteriore	1	1		1		3
990	990 Super Duke	2007-2010	HBK5034	Set Up RACE	1	1		1		3
990	990 Supermoto R ABS	2009-2013	HBK5047	Set Up OEM anteriore	5			2		7
1190	RC8 / R	2009-2011	HBK5040	Linea frizione					1	1
1190	RC8 / R	2009-2011	HBK5040	Set Up RACE	1	1		1		3
KYMCO										
125	Agility 125		HBF5452	Set Up OEM anteriore	1					1
125	People 125	2004-2005	HBF5450	Set Up OEM anteriore	1					1
250	Quad : 250R	2005	HBK5451	Set Up OEM anteriore	1	1	1	1		4
	Quad : Quadrunner		HBK5453	Set Up OEM anteriore	1	2		1		4
LAMBRETTA										
	Disc Brake Model Upgrade		HBF5475	Set Up OEM anteriore	1					1
LAVERDA										
500	500 Montjuic	1979-1983	HBK5508	Set Up OEM anteriore	1	2		1		4
500	500 Sport	1983-1984	HBK5513	Set Up OEM anteriore	1	2		1		4
500	500 Standard	1983-1984	HBK5515	Set Up OEM anteriore	1	2		1		4
650	650 Sport	1993-1997	HBK5558	Set Up OEM anteriore	1	1		1		3
750	750 Café Racer	2000-2001	HBK5522	Set Up OEM anteriore	1	2		1		4
750	750 Formula	1997-2002	HBK5518	Set Up OEM anteriore	1	2		1		4
750	750 S Strike	1998-2001	HBK5531	Set Up OEM anteriore	1	2		1		4
750	750 S Super Sport	2000-2001	HBK5532	Set Up OEM anteriore	1	2		1		4
750	750 SS	1997-2002	HBK5517	Set Up OEM anteriore	1	2		1		4
1000	RGA RGS 1000	1981-1986	HBC5543	Linea frizione					1	1
1000	RGA RGS 1000	1981-1986	HBK5543	Set Up OEM anteriore	1	2		1		4
1000	RGS 1000 Corsa	1984-1986	HBC5546	Linea frizione					1	1

CILIND.	MODELLO	ANNI	CODICE	CONFIGURAZIONE	ANT. SUP.	ANT. INF.	AGG.	POST.	FRIZ.	TOT. TUBI
1000	RGS 1000 Corsa	1984-1986	HBK5546	Set Up OEM anteriore	1	2		1		4
1000	RGS 1000 Executive	1983-1984	HBK5549	Set Up OEM anteriore	1	2		1		4
1000	SFC 1000 Sports	1985-1989	HBK5551	Set Up OEM anteriore	1	2		1		4
1200	1200 Sports	1978-1982	HBK5500	Set Up OEM anteriore	1	2		1		4
1200	1200 TS	1980-1982	HBK5505	Set Up OEM anteriore	1	2		1		4
1200	Formula Mirage 1200	1982	HBK5557	Set Up OEM anteriore	1	2		1		4
1200	Mirage 1200	1978-1979	HBC5542	Linea frizione					1	1
1200	Mirage 1200	1978-1979	HBK5542	Set Up OEM anteriore	1	2		1		4
	Jota 120 / 180	1978-1982	HBC5534	Linea frizione					1	1
	Jota 120	1978-1982	HBK5534	Set Up OEM anteriore	1	2		1		4
	Jota 180	1978-1982	HBK5536	Set Up OEM anteriore	1	2		1		4
	SFC	1976	HBK5556	Set Up OEM anteriore	1	2		1		4
LEXMOTO										
125	Venom EFI	2016	HBK7500	Set Up OEM anteriore	1	1		1		3
LML										
125	125	2016	HBK2901	Set Up OEM anteriore	1					1
150	150	2016	HBK2901	Set Up OEM anteriore	1					1
200	200	2016	HBK2901	Set Up OEM anteriore	1					1
MAICO										
	Moto Cross	1985	HBK5700	Set Up OEM anteriore	1					1
	Moto Cross	1986	HBK5701	Set Up OEM anteriore	1					1
MONTESA										
315	315R Trials	2001-2004	HBC8600	Linea frizione					1	1
315	315R Trials	2001-2004	HBK8600	Set Up OEM anteriore	1			1		2
MOTO GUZZI										
350	V35 (1977) & V50 MK II	1979-1983	HBK5833	Set Up OEM anteriore	1	1		1		3
350	V35 MK II - MK III	1984-1988	HBK5825	Set Up OEM anteriore	1	1	1	1		4
500	V50 MK III	1984-1986	HBK5838	Set Up OEM anteriore	1	1	1	1		4
500	V50 Monza MK I - MK II	1981-1983	HBK5841	Set Up OEM anteriore	1	1		1		3
500	V50 Monza MK III	1984-1986	HBK5842	Set Up OEM anteriore	1	1		1		3
650	V65 Lario	1985-1988	HBK5844	Set Up OEM anteriore	1	1	1	1		4
650	V65 SP	1985	HBK5852	Set Up OEM anteriore	1	1	1	1		4
650	V65 TT	1985-1988	HBK5848	Set Up OEM anteriore	1	1		1		3
750	750 S	1975	HBK5861	Set Up OEM anteriore	1	1		1		3
750	750 S3	1976	HBK5800	Set Up OEM anteriore	1	1	1	1		4
750	750 Targa	1990-1994	HBK5849	Set Up OEM anteriore	1	1	1			3
850	850 Le Mans MK II - MK III	1979-1985	HBK5815	Set Up OEM anteriore	1	1	1	1		4
850	850 Le Mans MK I	1978-1979	HBK5814	Set Up OEM anteriore	1	1	1	1		4
850	850 T3 ALL Models	1976-1980	HBK5801	Set Up OEM anteriore	1	2	1	1		5
850	850 T4	1980-1983	HBK5803	Set Up OEM anteriore	1	1	1	1		4
850	850 T5	1983-1988	HBK5807	Set Up OEM anteriore	1	1	1	1		4
1000	1000 (ie Daytona RS)	1992-2000	HBK5855	Set Up OEM anteriore	1	1		1		3
1000	1000 (ie Daytona)	1992-2000	HBK5856	Set Up OEM anteriore	1	1		1		3
1000	1000 Le Mans MK IV - MK V	1985-1994	HBK5817	Set Up OEM anteriore	1	1	1	1		4
1000	1000 Mille GT	1971	HBK5818	Set Up OEM anteriore	1	1				2
1000	1000 Mille GT	1988-1991	HBK5860	Set Up OEM anteriore	1	1	1	1		4
1000	1000 Spada MK I - MK II	1980-1988	HBK5820	Set Up OEM anteriore	1	1	1	1		4
1000	1000 Spada MK III	1989-1995	HBK5859	Set Up OEM anteriore	1	1	1	1		4

CILIND.	MODELLO	ANNI	CODICE	CONFIGURAZIONE	ANT. SUP.	ANT. INF.	AGG.	POST.	FRIZ.	TOT. TUBI
1000	Mistral SP 1000	1982	HBK5819	Set Up OEM anteriore	1	1	1	1		4
1000	SP1000 NT	1981	HBK5851	Set Up OEM anteriore	1	1	1	1		4
1100	1100 Sport (Carb)	1994-1996	HBK5853	Set Up OEM anteriore	1	1		1		3
1100	1100 Sport (Injection)	1996-1999	HBK5854	Set Up OEM anteriore	1	1		1		3
1100	California III	1988-1993	HBK5850	Set Up OEM anteriore	1	1	1	1		4
	Breva	2003-2008	HBK5858	Set Up RACE	1	1		1		3
	Breva	2003-2008	HBK5857	Set Up OEM anteriore	1	1	1	1		4
MOTO MORINI										
350	3,5	1979	HBK5877	Set Up OEM anteriore	1	2				3
500	501 Camel Sahara	1989	HBK5878	Set Up OEM anteriore	1			1		2
1200	Corsaro	2010	HBK5875	Linea frizione					1	1
1200	Corsaro	2010	HBK5876	Set Up RACE	1	1		1		3
1200	Corsaro	2010	HBK5875	Set Up OEM anteriore	1	1	1	1		4
MV AGUSTA										
500	Monza	1979	HBK5900	Set Up OEM anteriore	1	2		1		4
750	Brutale	2000-2005	HBK5903	Set Up OEM anteriore	3					3
750	F4 S F4 S-1 F4 SPR F4 SPR Senna	2000-2005	HBK5901	Linea frizione					1	1
750	F4 S F4 S-1 F4 SPR F4 SPR Senna	2000-2005	HBK5902	Set Up OEM anteriore	1					1
750	F4 S F4 S-1 F4 SPR F4 SPR Senna	2000-2005	HBK5901	Set Up RACE	1	1		1		3
	Brutale	2006-2007	HBK5904	Set Up OEM anteriore	3					3
MZ										
660	Mastiff / Baghira 660cc	1998-2007	HBK9990	Set Up OEM anteriore	1			1		2
NORTON										
750	Roadster 750	1972	HBK6019	Set Up OEM anteriore	1					1
750	Commando 750		HBK6002	Set Up OEM anteriore	1					1
850	Commando 850 MKIII	1975	HBK6003	Set Up OEM anteriore	1	1		1		3
850	Commando 850 MKIII	1976	HBK6004	Set Up OEM anteriore	1	1				2
	Commando	1973	HBK6001	Set Up OEM anteriore	1					1
	Commando MKIIA	1973	HBK6006	Set Up OEM anteriore	1					1
	Commando MKIIA	1974	HBK6007	Set Up OEM anteriore	1					1
	Commando MKIIA - US Model	1974	HBK6012	Set Up OEM anteriore	1					1
	Beta TR 34	1987	HBK6000	Set Up OEM anteriore	1			1		2
	Commando MKII	1976	HBK6005	Set Up OEM anteriore	1	1				2
	Commando MKIII	1975-1978	HBK6008	Set Up OEM anteriore	1	1		1		3
	Commando Roadster	1972	HBK6009	Set Up OEM anteriore	1	1				2
	Commando Rotary		HBK6010	Set Up OEM anteriore	1	2				3
	F1 / F1 Sport / F1 JPS Racing	1988-1993	HBK6011	Set Up OEM anteriore	1	1		1		3
	Commando MKIII Interstate	1975-1978	HBK6020	Set Up OEM anteriore	1	1		1		3
PEUGEOT										
50	Elyseo 50	2000-2007	HBK6517	Set Up OEM anteriore	1					1
100	Elyseo 100	2000-2007	HBK6518	Set Up OEM anteriore	1					1
125	Elyseo 125	2000-2007	HBK6519	Set Up OEM anteriore	1					1
150	Elyseo 150	2000-2007	HBK6516	Set Up OEM anteriore	1			1		2
500	Speedfight 1 50cc	1997-2007	HBK6500	Set Up OEM anteriore	1			1		2
500	Speedfight 2 50cc	2001-2007	HBK6515	Set Up OEM anteriore	1			1		2

CILIND.	MODELLO	ANNI	CODICE	CONFIGURAZIONE	ANT. SUP.	ANT. INF.	AGG.	POST.	FRIZ.	TOT. TUBI
PIAGGIO										
50	Fly	2005-2009	HBF6731	Set Up OEM anteriore	1					1
50	NRG Extreme	1997-2002	HBK6725	Set Up OEM anteriore	1			1		2
50	Zip	1997-2007	HBF6726	Set Up OEM anteriore	1					1
	T5	1998-2002	HBF6727	Set Up OEM anteriore	1					1
125	Vespa ET 4 125	1996-2007	HBF6730	Set Up OEM anteriore	1					1
125	Vespa ET4 / PX	1996-2007	HBF6728	Set Up OEM anteriore	1					1
500	B500		HBF6729	Set Up OEM anteriore	1					1
QUASAR										
	Quasar	1977-1983	HBK6740	Set Up OEM anteriore	1	2		1		4
ROYAL ENFIELD										
350	Bullet	2011-2014	HBF6751	Set Up OEM anteriore	1					1
500	Classic 500 Efi	2011-2014	HBF6752	Set Up OEM anteriore	1					1
500	Electra	2011-2014	HBF6753	Set Up OEM anteriore	1					1
500	Electra 500 Efi	2011-2014	HBF6757	Set Up OEM anteriore	1					1
500	Electra X	2004-2008	HBF6750	Set Up OEM anteriore	1					1
500	Bullet 500 Efi	2011-2014	HBF6758	Set Up OEM anteriore	1					1
535	Continental GT 535	2013-2014	HBK6754	Set Up OEM anteriore	1			1		2
SACHS										
125	125 Madman	2008-2011	HBK6756	Set Up OEM anteriore	1			1		2
125	XTC125	2000-2008	HBK6755	Set Up OEM anteriore	1			1		2
SAUBER										
500	GP500 Front Line Kit 2 Line	2001-2002	HBK6800	Set Up RACE	1	1				2
500	GP500 Front Line Kit 3 Line	2001-2002	HBK6801	Set Up OEM anteriore	1	1	1			3
SCOMADI										
250	TL250S	2009-2010	HBK6850	Set Up OEM anteriore	1			1		2
SHERCO										
	80 / 125 / 200 / 250 / 290 / 320	1999-2010	HBF6860	Set Up OEM anteriore	1					1
	2.5i / 300i Enduro	2012-?	HBC6862	Linea frizione					1	1
	2.5i / 5.1i / 5.5i Enduro	2012-?	HBK6861	Set Up OEM anteriore	1			1		2
SUZUKI										
50	AP50	1996-2002	HBF7664	Set Up OEM anteriore	1					1
50	AY50 Katana	1997-2003	HBR7003	Set Up OEM anteriore				1		1
50	TR50 Street Magic	1998-2000	HBF7013	Set Up OEM anteriore	1					1
50	ZR50 SKE - SKX	1983-1985	HBF7595	Set Up OEM anteriore	1					1
50	ZR50 SLKX Custom	1981-1982	HBF7601	Set Up OEM anteriore	1					1
80	RM80	1986-2003	HBK7623	Set Up OEM anteriore	1			1		2
80	RM80	2004-2005	HBK7686	Set Up OEM anteriore	1			1		2
85	RM85	2010	HBK7833	Set Up OEM anteriore	1			1		2
85	XN85 Turbo	1983-1986	HBK7594	Set Up OEM anteriore	1	2	2	1		6
125	125 FU	1993	HBK7001	Set Up OEM anteriore	1			1		2
125	Address 125	2008	HBF7762	Set Up OEM anteriore	1					1
125	DR125 SD - SE	1983-1985	HBF7007	Set Up OEM anteriore	1					1
125	DR125 SF - SJ Raider	1985-1994	HBF7009	Set Up OEM anteriore	1					1
125	DR125SM	2008-2012	HBK7760	Set Up OEM anteriore	1			1		2
125	GN125	1998	HBF7770	Set Up OEM anteriore	1					1

CILIND.	MODELLO	ANNI	CODICE	CONFIGURAZIONE	ANT. SUP.	ANT. INF.	AGG.	POST.	FRIZ.	TOT. TUBI
125	GP125 D	1983-1989	HBF7051	Set Up OEM anteriore	1					1
125	GP125 N (Re Intro 79-82 Mod)	1985-1986	HBF7058	Set Up OEM anteriore	1					1
125	GP125 X - D	1982-1989	HBF7060	Set Up OEM anteriore	1					1
125	GS125 ESZ - ESX	1982-2000	HBF7068	Set Up OEM anteriore	1					1
125	GS125 S Katana	1980	HBK7077	Set Up OEM anteriore	1		1			2
125	GT125 L - B	1974-1977	HBF7393	Set Up OEM anteriore	1					1
125	RG125 F Gamma	1991-1995	HBF7000	Set Up OEM anteriore	1					1
125	RG125 FUN - FUR Gamma	1991-1995	HBF7435	Set Up OEM anteriore	1					1
125	RG125 UG - UJ Gamma	1986-1991	HBF7440	Set Up OEM anteriore	1					1
125	RM125	1988-1998	HBK7712	Set Up OEM anteriore	1			1		2
125	RM125	1999-2005	HBK7685	Set Up OEM anteriore	1			1		2
125	RM125	2006-2012	HBK7831	Set Up OEM anteriore	1			1		2
125	TS125 RK - RR	1990-1996	HBK7516	Set Up OEM anteriore	1			1		2
125	TS125 XF - XJ	1985-1989	HBF7523	Set Up OEM anteriore	1					1
125	Van Van RV125	2003-2015	HBF7744	Set Up OEM anteriore	1					1
125	VL125 Intruder	2005-2008	HBF7749	Set Up OEM anteriore	1					1
125	GSX-R125 ABS L7 - L8	2017-2018	HBK7021	Set Up OEM anteriore	1	1	1	1		4
125	GSX-S125 ABS L7 - L9	2017-2019	HBK7025	Set Up OEM anteriore	2			2		4
250	250 ET - ET	1980	HBF7002	Set Up OEM anteriore	1					1
250	GN250	1987-1997	HBF7014	Set Up OEM anteriore	1					1
250	GS250 TT - TX	1980-1981	HBF7078	Set Up OEM anteriore	1					1
250	GSX250 ET - EX	1980-1981	HBF7223	Set Up OEM anteriore	1					1
250	GSX250 EZ Katana	1982	HBK7225	Set Up OEM anteriore	1		1			2
250	GW250 Inazuma L5-L7	1992-2017	HBK7036	Set Up OEM anteriore	1			1		2
250	GT250 A	1976	HBF7395	Set Up OEM anteriore	1					1
250	GT250 B	1977	HBF7396	Set Up OEM anteriore	1					1
250	GT250 C	1978	HBF7397	Set Up OEM anteriore	1					1
250	GT250 EN - EX X7	1979-1982	HBF7398	Set Up OEM anteriore	1					1
250	GT250 K	1973	HBF7399	Set Up OEM anteriore	1					1
250	GT250 L	1974	HBF7400	Set Up OEM anteriore	1					1
250	Quad : LTZ250	2004-2006	HBK7689	Set Up OEM anteriore	1	1		1		3
250	RG250 F Gamma	1983-1983	HBF7004	Set Up OEM anteriore	1					1
250	RG250 F Gamma Mk II	1984-1989	HBK7005	Set Up OEM anteriore	1	2	2	1		6
250	RG250 FCH Gamma	1987-1989	HBK7452	Set Up OEM anteriore	1	2		1		4
250	RG250 FG - FH Gamma	1985-1989	HBK7455	Set Up OEM anteriore	1	2		1		4
250	RG250 WD Mk I Gamma	1983	HBK7459	Set Up OEM anteriore	1	2		1		4
250	RG250 WE Mk II Gamma	1984	HBK7460	Set Up OEM anteriore	1	2		1		4
250	RGV250 K - L	1989-1990	HBK7791	Set Up RACE	1	1		1		3
250	RGV250 K - L	1989-1990	HBK7466	Set Up OEM anteriore	1	2		1		4
250	RGV250 M - N	1991-1992	HBK7469	Set Up RACE	1	1		1		3
250	RGV250 M - N	1991-1992	HBK7468	Set Up OEM anteriore	1	2		1		4
250	RGV250 P - R	1993-1994	HBK7475	Set Up RACE	1	1		1		3
250	RGV250 P - R	1993-1994	HBK7474	Set Up OEM anteriore	1	2		1		4
250	RGV250 SP VJ23 Import	1996-1998	HBK7690	Set Up sopra parafrangente anteriore	1	1		1		3
250	RGV250 VJ21	1988	HBK7840	Set Up OEM anteriore	1	1	1	1		4
250	RM250	1976-1998	HBK7817	Set Up OEM anteriore	1			1		2
250	RM250	1999-2005	HBK7687	Set Up OEM anteriore	1			1		2
250	RM250	2006-2009	HBK7672	Set Up OEM anteriore	1					2

CILIND.	MODELLO	ANNI	CODICE	CONFIGURAZIONE	ANT. SUP.	ANT. INF.	AGG.	POST.	FRIZ.	TOT. TUBI
250	RMX250	1999-2005	HBK7696	Set Up OEM anteriore	1			1		2
250	RMZ250	2004-2006	HBK7688	Set Up OEM anteriore	1			1		2
250	RMZ250	2007-2013	HBK7043	Set Up OEM anteriore	1			1		2
250	TS250 XG - XJ	1985-1989	HBF7531	Set Up OEM anteriore	1					1
250	TU250X	1997-2000	HBF7792	Set Up OEM anteriore	1					1
350	DR350 SES - SEX	1995-1999	HBK7024	Set Up OEM anteriore	1			1		2
350	DR350 SL - SR	1990-1994	HBK7019	Set Up OEM anteriore	1			1		2
380	GT380 J	1972	HBF7401	Set Up OEM anteriore	1					1
380	GT380 K	1973	HBF7402	Set Up OEM anteriore	1					1
380	GT380 L	1974	HBF7403	Set Up OEM anteriore	1					1
380	GT380 M	1975	HBF7404	Set Up OEM anteriore	1					1
400	AN400 Burgman	2004-2008	HBK7737	Set Up OEM anteriore	1	1	1	1		4
400	DR-Z400 S	1999-2006	HBK7632	Set Up OEM anteriore	1			1		2
400	DR-Z400 SM	2004-2005	HBK7692	Set Up OEM anteriore	1			1		2
400	DR-Z400 SM	2006-2008	HBK7738	Set Up OEM anteriore	1			1		2
400	GN400 TT	1980-1982	HBF7042	Set Up OEM anteriore	1					1
400	GS400 Single Disc	1977-1980	HBK7082	Set Up OEM anteriore	1	1				2
400	GS425 Single Disc	1977-1980	HBK7083	Set Up OEM anteriore	1	1				2
400	GSF400 M - R Bandit Single Disc	1991-1995	HBK7168	Set Up OEM anteriore	1	1		1		3
400	GSF400 M - R Bandit Twin Disc	1991-1995	HBK7751	Set Up OEM anteriore	1	1	1	1		4
400	GSF400 V - Y Bandit	1996-2003	HBK7681	Set Up OEM anteriore	1	2		1		4
400	GSX400 D	1986	HBK7229	Set Up OEM anteriore	1	2	1			4
400	GSX400 E	1986	HBK7230	Set Up OEM anteriore	1		1			2
400	GSX400 EX - EZ	1980-1985	HBK7231	Set Up OEM anteriore	1		1			2
400	GSX400 FX Non Antidive	1981	HBK7237	Set Up OEM anteriore	1	2		1		4
400	GSX400 FZ - FD Anti Dive	1982-1986	HBK7240	Set Up OEM anteriore	1	2	1			4
400	GSX400 SSN Katana	1992-1993	HBK7684	Set Up RACE	1	1		1		3
400	GSX400 SSN Katana	1992-1993	HBK7683	Set Up OEM anteriore	1	2		1		4
400	GSX400 TX Custom	1981-1985	HBF7243	Set Up OEM anteriore	1					1
400	GSXR400 GK71B	1986-1987	HBK7807	Set Up OEM anteriore	1	2	2	1		6
400	GSXR400 GK71F	1986-1987	HBK7804	Set Up RACE	1	1				2
400	GSXR400 GK71F	1986-1987	HBK7803	Set Up OEM anteriore	1	2				3
400	GSXR400 RRSP Import	1987-1989	HBK7350	Set Up OEM anteriore	1	2		1		4
400	GSXR400R GK76A	1990-1992	HBK7342	Set Up RACE	1	1		1		3
400	GSXR400R GK76A	1990-1992	HBK7341	Set Up OEM anteriore	1	1	1	1		4
400	Quad : LTZ400	2003-2006	HBK7665	Set Up OEM anteriore	1	1		1		3
400	Quad : LTZ400 - ATV A Arms	2006	HBK7736	Set Up OEM anteriore	1	2		1		4
400	RG400 Gamma	1985-1986	HBK7462	Set Up OEM anteriore	1	2				3
450	GS450 EG - EJ	1985-1989	HBK7084	Set Up OEM anteriore	1	1				2
450	LT-R450 Quadracer K6-L1	2006-2011	HBK7026	Set Up RACE	1	1		1		3
450	Quad : LTR450	2006-2011	HBK7734	Set Up OEM anteriore	1	1	1	1		4
450	Quad : LTR450 - ATV A Arms	2006-2011	HBK7734	Set Up OEM anteriore	1	1	1	1		4
450	Quad : LTR450 QR Spec Only	2006-2011	HBK7734	Set Up RACE	1	1		1		3
450	RMZ450	2005-2008	HBK7735	Set Up OEM anteriore	1			1		2
450	RMZ450	2009-2013	HBK7828	Set Up OEM anteriore	1			1		2
500	GS500	2004-2008	HBK7675	Set Up OEM anteriore	1			1		2
500	GS500 EK - ER	1989-1994	HBK7090	Set Up OEM anteriore	1			1		2
500	GS500 ES - K2	1995-2002	HBK7097	Set Up OEM anteriore	1			1		2
500	GS500F	2003-2008	HBK7676	Set Up OEM anteriore	1			1		2

CILIND.	MODELLO	ANNI	CODICE	CONFIGURAZIONE	ANT. SUP.	ANT. INF.	AGG.	POST.	FRIZ.	TOT. TUBI
500	GT500 A	1975-1978	HBK7405	Set Up OEM anteriore	1					1
500	RG500 G - CH Gamma Sports	1985-1989	HBK7461	Set Up OEM anteriore	1	2		1		4
550	GS550 D	1977-1978	HBK7808	Set Up OEM anteriore	1	2				3
550	GS550 EN	1978-1979	HBK7780	Set Up OEM anteriore	1	2		1		4
550	GS550 ET - EX	1980-1981	HBK7781	Set Up OEM anteriore	1	2		1		4
550	GS550 EZ Antidive	1982-1985	HBK7107	Set Up OEM anteriore	1	2	2	1		6
550	GS550 LT - LX	1980-1982	HBK7111	Set Up OEM anteriore	1	2		1		4
550	GS550 MX Katana	1981-1984	HBK7715	Set Up OEM anteriore	1	2				3
550	GSX550 ESD / EE / ESE / EFE	1983-1984	HBK7248	Set Up OEM anteriore	1	2	2	1		6
550	GSX550 ESE (Non Antidive)	1986-1986	HBK7705	Set Up RACE	1	1		1		3
550	GSX550 ESE (Non Antidive)	1986-1986	HBK7704	Set Up OEM anteriore	1	2		1		4
550	GT550 A	1976	HBK7835	Set Up OEM anteriore	1					1
550	GT550 K	1973	HBK7750	Set Up OEM anteriore	1	1				2
550	GT550 L-M	1973	HBK7750	Set Up OEM anteriore	1	1				2
600	DR600 RG Paris Dakar	1986-1987	HBK7030	Set Up OEM anteriore	1					1
600	DR600 SF - RG Raider	1984-1987	HBK7032	Set Up OEM anteriore	1					1
600	GSF600 S - T - X Bandit	1995-1999	HBK7175	Set Up RACE	1	1		1		3
600	GSF600 S - T - X Bandit	1995-1999	HBK7174	Set Up OEM anteriore	1	2		1		4
600	GSF600 Y-K4 Bandit	2000-2004	HBK7189	Set Up RACE	1	1		1		3
600	GSF600 Y-K4 Bandit	2000-2004	HBK7188	Set Up OEM anteriore	1	2		1		4
600	GSR600	2006-2010	HBK7726	Set Up RACE	1	1		1		3
600	GSR600	2006-2010	HBK7727	Set Up sopra parafango anteriore	1	1		1		3
600	GSR600 ABS	2007-2010	HBK7027	Set Up OEM anteriore	3			2		5
650	SFV650 Gladius ABS	2009-2016	HBK7029	Set Up OEM anteriore	4			2		6
600	GSX600 F Katana	2004-2005	HBK7701	Set Up RACE	1	1		1		3
600	GSX600 F Katana	2004-2005	HBK7700	Set Up OEM anteriore	1	2		1		4
600	GSX600 FJ - FV	1988-1997	HBK7607	Set Up RACE	1	1		1		3
600	GSX600 FJ - FV	1988-1997	HBK7259	Set Up OEM anteriore	1	2		1		4
600	GSX600 FW - K4	1998-2004	HBK7616	Set Up RACE	1	1		1		3
600	GSX600 FW - K4	1998-2004	HBK7268	Set Up OEM anteriore	1	2		1		4
600	GSXR600 K1 - K3	2001-2003	HBK7363	Set Up RACE	1	1		1		3
600	GSXR600 K1 - K3	2001-2003	HBK7364	Set Up sopra parafango anteriore	1	1		1		3
600	GSXR600 K4 - K5	2004-2005	HBK7679	Set Up RACE	1	1		1		3
600	GSXR600 K4 - K5	2004-2005	HBK7680	Set Up sopra parafango anteriore	1	1		1		3
600	GSXR600 K6 - K7	2006-2007	HBK7728	Set Up RACE	1	1		1		3
600	GSXR600 K6 - K7	2006-2007	HBK7729	Set Up sopra parafango anteriore	1	1		1		3
600	GSXR600 K8	2008-2008	HBK7771	Set Up RACE	1	1		1		3
600	GSXR600 K8	2008-2008	HBK7797	Set Up sopra parafango anteriore	1	1		1		3
600	GSXR600 K9 - L0	2009-2010	HBK7800	Set Up sopra parafango anteriore	1	1		1		3
600	GSXR600 K9 - L0	2009-2010	HBK7801	Set Up RACE	1	1		1		3
600	GSXR600 L1-L6	2011-2018	HBK7820	Set Up sopra parafango anteriore	1	1		1		3
600	GSXR600 L1-L6	2011-2018	HBK7821	Set Up RACE	1	1		1		3
600	GSXR600 V - W SRAD	1997-1998	HBK7353	Set Up RACE	1	1		1		3
600	GSXR600 V - W SRAD	1997-1998	HBK7354	Set Up sopra parafango anteriore	1	1		1		3

CILIND.	MODELLO	ANNI	CODICE	CONFIGURAZIONE	ANT. SUP.	ANT. INF.	AGG.	POST.	FRIZ.	TOT. TUBI
600	GSXR600 X - Y SRAD	1999-2000	HBK7359	Set Up RACE	1	1		1		3
600	GSXR600 X - Y SRAD	1999-2000	HBK7360	Set Up sopra parafango anteriore	1	1		1		3
600	RF600 RP - RV	1993-1997	HBK7720	Set Up RACE	1	1		1		3
600	RF600 RP - RV	1993-1997	HBK7422	Set Up OEM anteriore	1	2		1		4
600	VS600 GLS - GLT Intruder	1995-1997	HBK7555	Set Up OEM anteriore	1					1
650	AN650 Burgman ABS	2013-2018	HBK7028	Set Up OEM anteriore	4			2		6
650	AN650 Burgman Executive ABS	2006-2012	HBK7046	Set Up OEM anteriore	4			2		6
650	Burgman 650 Executive	2004-2011	HBK7748	Set Up OEM anteriore	1	1	1	1		4
650	DL650 V-Strom	2003-2008	HBK7673	Set Up RACE	1	1		1		3
650	DL650 V-Strom	2003-2008	HBK7699	Set Up sopra parafango anteriore	1	1		1		3
650	DL650 V-Strom ABS K7- L1	2007-2011	HBK7847	Set Up OEM anteriore	6			2		8
650	DL650 V-Strom ABS L2 - L6	2012-2021	HBK7845	Set Up OEM anteriore	3			2		5
650	DR650	1996-2003	HBK7836	Set Up OEM anteriore	1			1		2
650	DR650R SE	1991-2014	HBK7656	Set Up OEM anteriore	1			1		2
650	GS650 GTX - GTD	1981-1985	HBK7114	Set Up OEM anteriore	1	2		1		4
650	GS650 GX Katana	1981-1984	HBK7120	Set Up OEM anteriore	1	2		1		4
650	GS650 GZ Antidive	1982-1984	HBK7124	Set Up OEM anteriore	1	2	2	1		6
650	GS650G Anti Dive	1981	HBK7841	Set Up OEM anteriore	1	2	2	1		6
650	GSF650 K5 - K8 Bandit Faired	2005-2006	HBK7815	Set Up RACE	1	1		1		3
650	GSF650 K5 - K8 Bandit Faired	2005-2006	HBK7816	Set Up sopra parafango anteriore	1	1		1		3
650	GSF650 K5 - K8 Bandit Naked	2005-2006	HBK7709	Set Up sopra parafango anteriore	1	1		1		3
650	GSF650 K5 - K8 Bandit Naked	2005-2006	HBK7711	Set Up RACE	1	1		1		3
650	GSF650 K7 - L2 Bandit Naked	2007-2012	HBK7031	Set Up sopra parafango anteriore	1	1		1		3
650	GSF650 K7 - L2 Bandit Naked	2007-2012	HBK7033	Set Up RACE	1	1		1		3
650	GSF650 K7 - L2 Bandit Faired	2007-2012	HBK7034	Set Up RACE	1	1		1		3
650	GSF650 K7 - L2 Bandit Faired	2007-2012	HBK7035	Set Up sopra parafango anteriore	1	1		1		3
650	GSF650 SA Bandit	2007-2016	HBC7709	Linea frizione					1	1
650	GSF650S ABS Bandit Front	2005-2006	HBK7708	Set Up OEM anteriore	2	1	1	1		5
650	GSF650S ABS Bandit Rear	2005-2006	HBK7708	Set Up OEM anteriore			1	1		2
650	GSF650S ABS Bandit Front	2007-2016	HBK7834	Set Up OEM anteriore	1	1	1	1		4
650	GSF650S ABS Bandit Rear	2007-2016	HBR7834	Set Up OEM anteriore			1	1		2
650	GSX650F ABS K8-L5 7x Line Kit	2008-2015	HBK7714	Set Up OEM anteriore	7					7
650	GSX650F K8-L2 Non ABS	2008-2012	HBK7765	Set Up RACE	1	1		1		3
650	GSX650F K8-L2 Non ABS	2008-2015	HBK7764	Set Up sopra parafango anteriore	1	1		1		3
650	LS650 FG - PJ - PT Savage	1987-1998	HBK7408	Set Up OEM anteriore	1					1
650	SFV650 Gladius	2009-2016	HBK7812	Set Up RACE	1	1		1		3
650	SFV650 Gladius	2009-2016	HBK7813	Set Up sopra parafango anteriore	1	1		1		3
650	SV650 (Naked)	2004-2004	HBK7809	Set Up OEM anteriore	1	1	1	1		4
650	SV650 N K3 - K8	2003-2008	HBK7694	Set Up RACE	1	1		1		3
650	SV650 N K3 - K8	2003-2008	HBK7811	Set Up sopra parafango anteriore	1	1		1		3
650	SV650 N K3 - K8	2003-2008	HBK7693	Set Up OEM anteriore	1	2		1		4
650	SV650 N X - K2	1999-2002	HBK7485	Set Up RACE	1	1		1		3

CILIND.	MODELLO	ANNI	CODICE	CONFIGURAZIONE	ANT. SUP.	ANT. INF.	AGG.	POST.	FRIZ.	TOT. TUBI
650	SV650 N X - K2	1999-2002	HBK7484	Set Up OEM anteriore	1	2		1		4
650	SV650 N ABS K7 - L5	2007-2015	HBK7098	Set Up OEM anteriore	3			2		5
650	SV650 SK3 - SK5 Faired Model	2003-2005	HBK7646	Set Up RACE	1	1		1		3
650	SV650 SK6 - SK8 Faired Model	2006-2008	HBK7810	Set Up RACE	1	1		1		3
650	SV650 SK6 - SK8 Faired Model	2006-2008	HBK7758	Set Up OEM anteriore	1	1	1	1		4
650	SV650 SK9 - SK13 Faired Model	2009-2013	HBK7838	Set Up RACE	1	1		1		3
650	SV650 SK9 - SK13 Faired Model	2009-2013	HBK7839	Set Up sopra parafango anteriore	1	1		1		3
650	SV650 SX - SK2 Faired Model	1999-2002	HBK7490	Set Up RACE	1	1		1		3
650	SV650 SX - SK2 Faired Model	1999-2002	HBK7491	Set Up OEM anteriore	1	2		1		4
650	SV650 S ABS	2007-2015	HBK7044	Set Up OEM anteriore	3			2		5
650	XF650 V - Y Freewind	1997-2001	HBK7589	Set Up OEM anteriore	1			1		2
650	SV650A ABS L6-L8	2016-2018	HBK7017	Set Up OEM anteriore	3			2		5
650	SV650 X L8-L9 ABS	2018-2019	HBK7022	Set Up OEM anteriore	3			2		5
750	DR750 S J - K Desert Express / Dr Big	1988-1989	HBK7037	Set Up OEM anteriore	1			1		2
750	GS750	1977-1978	HBK7127	Set Up OEM anteriore	1	1				2
750	GS750 B	1977	HBK7739	Set Up OEM anteriore	1			1		2
750	GS750 D/DN/EN	1979	HBK7128	Set Up OEM anteriore	1	2		1		4
750	GS750 DB	1977	HBK7129	Set Up OEM anteriore	1	2		1		4
750	GS750 LX US Import		HBK7130	Set Up OEM anteriore	1	2				3
750	GSR750 ABS L2-L6	2012-2016	HBK7843	Set Up OEM anteriore	4			1		5
750	GSR750 L1-L6	2011-2016	HBK7826	Set Up RACE	1	1		1		3
750	GSR750 L1-L6	2011-2016	HBK7827	Set Up sopra parafango anteriore	1	1		1		3
750	GSX750 EE / EF / ES Antidive	1984-1989	HBK7273	Set Up OEM anteriore	1	2	2	1		6
750	GSX750 ESD Antidive	1983	HBK7278	Set Up OEM anteriore	1	2	2	1		6
750	GSX750 ET - EX	1980-1981	HBK7785	Set Up RACE	1	1		1		3
750	GSX750 ET - EX	1980-1981	HBK7784	Set Up OEM anteriore	1	2		1		4
750	GSX750 FK - FV	1989-1997	HBK7787	Set Up RACE	1	1		1		3
750	GSX750 FK - FV	1989-1997	HBK7287	Set Up OEM anteriore	1	2		1		4
750	GSX750 FW - FK5	1998-2005	HBK7300	Set Up RACE	1	1		1		3
750	GSX750 FW - FK5	1998-2005	HBK7299	Set Up OEM anteriore	1	2		1		4
750	GSX750 SE Katana (Non Flip Up)	1984	HBK7814	Set Up OEM anteriore	1	2	2	1		6
750	GSX750 SF Katana	1985-1986	HBK7285	Linea frizione					1	1
750	GSX750 SF Katana	1985-1986	HBK7285	Set Up OEM anteriore	1	2		1		4
750	GSX750 W - K1 Retro	1997-2002	HBK7309	Set Up OEM anteriore	1	2		1		4
750	GSXR750 / 3 Japanese Import	1991	HBK7380	Linea frizione					1	1
750	GSXR750 / 3 Japanese Import	1991	HBK7380	Set Up OEM anteriore	1	2		1		4
750	GSXR750 F - H	1985-1987	HBK7365	Linea frizione					1	1
750	GSXR750 F - H	1985-1987	HBK7719	Set Up RACE	1	1		1		3
750	GSXR750 F - H	1985-1987	HBK7365	Set Up OEM anteriore	1	2		1		4
750	GSXR750 J - M	1988-1991	HBK7368	Linea frizione					1	1
750	GSXR750 J Slingshot	1988	HBK7717	Set Up RACE	1	1		1		3
750	GSXR750 J Slingshot	1988	HBK7368	Set Up OEM anteriore	1	2		1		4
750	GSXR750 K Slingshot	1989	HBK7718	Set Up RACE	1	1		1		3
750	GSXR750 K Slingshot	1989	HBK7369	Set Up OEM anteriore	1	2		1		4
750	GSXR750 K4 - K5	2004-2005	HBK7670	Set Up RACE	1	1		1		3

CILIND.	MODELLO	ANNI	CODICE	CONFIGURAZIONE	ANT. SUP.	ANT. INF.	AGG.	POST.	FRIZ.	TOT. TUBI
750	GSXR750 K4 - K5	2004-2005	HBK7671	Set Up sopra parafango anteriore	1	1		1		3
750	GSXR750 K6 - K7	2006-2007	HBK7730	Set Up RACE	1	1		1		3
750	GSXR750 K6 - K7	2006-2007	HBK7731	Set Up sopra parafango anteriore	1	1		1		3
750	GSXR750 K8	2008-2008	HBK7768	Set Up sopra parafango anteriore	1	1		1		3
750	GSXR750 K8	2008-2008	HBK7769	Set Up RACE	1	1		1		3
750	GSXR750 K9 - L0	2009-2010	HBK7798	Set Up sopra parafango anteriore	1	1		1		3
750	GSXR750 K9 - L0	2009-2010	HBK7799	Set Up RACE	1	1		1		3
750	GSXR750 L Slingshot	1990	HBK7371	Set Up RACE	1	1		1		3
750	GSXR750 L Slingshot	1990	HBK7370	Set Up OEM anteriore	1	2		1		4
750	GSXR750 L1 - L8	2011-2018	HBK7818	Set Up sopra parafango anteriore	1	1		1		3
750	GSXR750 L1 - L8	2011-2018	HBK7819	Set Up RACE	1	1		1		3
750	GSXR750 M Slingshot	1991	HBK7790	Set Up RACE	1	1		1		3
750	GSXR750 M Slingshot	1991	HBK7372	Set Up OEM anteriore	1	2		1		4
750	GSXR750 T - W SRAD	1996-1998	HBK7381	Set Up RACE	1	1		1		3
750	GSXR750 T - W SRAD	1996-1998	HBK7382	Set Up sopra parafango anteriore	1	1		1		3
750	GSXR750 WN - WP	1992-1993	HBK7373	Set Up OEM anteriore	1	2		1		4
750	GSXR750 WR - WS	1994-1995	HBK7378	Set Up sopra parafango anteriore	1	1		1		3
750	GSXR750 WR - WS	1994-1995	HBK7379	Set Up RACE	1	1		1		3
750	GSXR750 WT	1996-1996	HBK7682	Set Up sopra parafango anteriore	1	1		1		3
750	GSXR750 X SRAD	1999	HBK7387	Set Up RACE	1	1		1		3
750	GSXR750 X SRAD	1999	HBK7388	Set Up sopra parafango anteriore	1	1		1		3
750	GSXR750 Y - K3	2000-2003	HBK7391	Set Up RACE	1	1		1		3
750	GSXR750 Y - K3	2000-2003	HBK7392	Set Up sopra parafango anteriore	1	1		1		3
750	GSX-S750 NON ABS L5-L6 - OVERSEAS MODELS ONLY	2015-2016	HBK7040	Set Up sopra parafango anteriore	1	1		1		3
750	GSX-S750 ABS	2017-2021	HBK7016	Set Up OEM anteriore	1	1	1	1		4
750	GT750 (K L M A B) Replaces the metal lines from the Front Calipers	1973-1977	HBK7406	Set Up OEM anteriore	1	2		1		4
750	GT750 (K L M A B) Retains the metal lines from the Front Calipers	1973-1977	HBK7407	Set Up OEM anteriore	1	2		1		4
750	VS750 GLPG - GLPM Intruder	1985-1991	HBC7559	Linea frizione					1	1
750	VS750 GLPG - GLPM Intruder	1985-1991	HBK7559	Set Up OEM anteriore	1					1
800	C800 Intruder	2001-2015	HBK7746	Set Up OEM anteriore	1					1
800	DR800 S L Dr Big	1990-1990	HBK7041	Set Up OEM anteriore	1			1		2
800	DR800 S M - V Dr Big	1991-2000	HBK7039	Set Up OEM anteriore	1			1		2
800	M50 (M800) Boulevard / Intruder	2011	HBK7822	Set Up OEM anteriore	1			1		2
800	M800 Intruder	2006-2008	HBK7745	Set Up OEM anteriore	1					1
800	M800 Intruder VZ800	2006-2008	HBK7585	Set Up OEM anteriore	1					1
800	VS800 GL - GLV Volusia	1991-1997	HBK7716	Set Up OEM anteriore	1					1
800	VS800 GL - GLV Volusia	1997-2004	HBK7802	Set Up OEM anteriore	1					1
800	VX800 GLM - GLV Roadster	1991-1997	HBK7574	Set Up OEM anteriore	1			1		2

CILIND.	MODELLO	ANNI	CODICE	CONFIGURAZIONE	ANT. SUP.	ANT. INF.	AGG.	POST.	FRIZ.	TOT. TUBI
800	VX800 GLM - GLV Roadster US / Euro Import	1991-1996	HBK7566	Set Up OEM anteriore	1			1		2
800	VZ800 Intruder	2007-2009	HBK7794	Set Up OEM anteriore	1					1
800	VZ800 Marauder	1997-1998	HBK7584	Set Up OEM anteriore	1					1
850	GS850 GN - GT	1979-1980	HBK7131	Set Up OEM anteriore	1	2		1		4
850	GS850 GX - GG	1981-1988	HBK7132	Set Up OEM anteriore	1	2		1		4
900	RF900 RR - RW	1994-1998	HBC7428	Linea frizione					1	1
900	RF900 RR - RW	1994-1998	HBK7721	Set Up RACE	1	1		1		3
900	RF900 RR - RW	1994-1998	HBC7428	Set Up OEM anteriore	1	2		1		4
1000	DL1000 V-Strom	2002-2008	HBC7663	Linea frizione					1	1
1000	DL1000 V-Strom	2002-2008	HBK7695	Set Up RACE	1	1		1		3
1000	DL1000 V-Strom	2002-2008	HBC7663	Set Up OEM anteriore	1	1	1	1		4
1000	DL1000 V-Strom ABS	2014-2016	HBC7008	Linea frizione					1	1
1000	DL1000 V-Strom ABS	2014-2016	HBK7008	Set Up OEM anteriore	4			1		5
1000	GS1000 E GS1000ET	1980-1984	HBK7062	Set Up OEM anteriore	1	2		1		4
1000	GS1000 EN	1979	HBK7775	Set Up OEM anteriore	1	2		1		4
1000	GS1000 ET - GT	1980-1984	HBK7776	Set Up OEM anteriore	1	2		1		4
1000	GS1000 G	1980-1983	HBK7779	Set Up OEM anteriore	1	2		1		4
1000	GS1000 L US Import	1980	HBK7777	Set Up OEM anteriore	1	2		1		4
1000	GS1000 S	1979	HBK7778	Set Up OEM anteriore	1	2		1		4
1000	GSX1000 SZ - SD Katana	1981-1984	HBK7200	Set Up OEM anteriore	1	2	2	1		6
1000	GSXR1000 K1 - K2	2001-2002	HBK7314	Set Up RACE	1	1		1		3
1000	GSXR1000 K1 - K2	2001-2002	HBK7315	Set Up sopra parafango anteriore	1	1		1		3
1000	GSXR1000 K3 - K4	2003-2004	HBK7630	Set Up sopra parafango anteriore	1	1		1		3
1000	GSXR1000 K3 - K4	2003-2004	HBK7631	Set Up RACE	1	1		1		3
1000	GSXR1000 K5 - K6	2005-2006	HBK7706	Set Up sopra parafango anteriore	1	1		1		3
1000	GSXR1000 K5 - K6	2005-2006	HBK7707	Set Up RACE	1	1		1		3
1000	GSXR1000 K7	2007-2007	HBK7752	Set Up sopra parafango anteriore	1	1		1		3
1000	GSXR1000 K7	2007-2007	HBK7753	Set Up RACE	1	1		1		3
1000	GSXR1000 K7 - K8	2007-2008	HBC7752	Linea frizione					1	1
1000	GSXR1000 K8	2008-2008	HBK7772	Set Up sopra parafango anteriore	1	1		1		3
1000	GSXR1000 K8	2008-2008	HBK7773	Set Up RACE	1	1		1		3
1000	GSXR1000 K9 - L1	2009-2011	HBK7795	Set Up RACE	1	1		1		3
1000	GSXR1000 K9 - L1	2009-2011	HBK7796	Set Up sopra parafango anteriore	1	1		1		3
1000	GSXR1000 L2 - L6	2012-2016	HBK7829	Set Up sopra parafango anteriore	1	1		1		3
1000	GSXR1000 L2 - L6	2012-2016	HBK7830	Set Up RACE	1	1		1		3
1000	GSXR1000 L5 - L6 ABS	2015-2016	HBK7006	Set Up OEM anteriore	4			1		5
1000	GSXR1000 L7 ABS	2017-2019	HBK7015	Set Up OEM anteriore	4			2		6
1000	GSXR1000 L7 no ABS	2017-2018	HBFKK0005	Set Up RACE	1	1		1		3
1000	GSX-S1000F & GSX-S1000 (Non ABS)	2015-2016	HBK7011	Set Up RACE	1	1		1		3
1000	GSX-S1000F & GSX-S1000 (Non ABS)	2015-2016	HBK7010	Set Up OEM anteriore	1	2		1		4
1000	GSX-S1000F & GSX-S1000 ABS	2015-2020	HBK7012	Set Up OEM anteriore	3			2		5

CILIND.	MODELLO	ANNI	CODICE	CONFIGURAZIONE	ANT. SUP.	ANT. INF.	AGG.	POST.	FRIZ.	TOT. TUBI
1000	SV1000 N	2003-2006	HBK7637	Set Up sopra parafango anteriore	1	1		1		3
1000	SV1000 N	2003-2006	HBK7638	Set Up RACE	1	1		1		3
1000	SV1000 Top Yoke Conversion	2003-2006	HBK7639	Set Up OEM anteriore	1	1		1		3
1000	SV1000J Top Yoke Conversion	2003	HBK7639	Linea frizione					1	1
1000	SV1000S	2003-2007	HBK7666	Linea frizione					1	1
1000	SV1000S Faired Model	2003-2006	HBK7666	Set Up RACE	1	1		1		3
1000	SV1000S Faired Model	2003-2006	HBK7667	Set Up sopra parafango anteriore	1	1		1		3
1000	TL1000R W-K2	1998-2002	HBK7496	Linea frizione					1	1
1000	TL1000R W-K2	1998-2002	HBK7496	Set Up RACE	1	1		1		3
1000	TL1000R W-K2	1998-2002	HBK7497	Set Up sopra parafango anteriore	1	1		1		3
1000	TL1000S V-K1	1997-2001	HBK7504	Set Up RACE	1	1		1		3
1000	TL1000S V-K1	1997-2001	HBK7505	Set Up sopra parafango anteriore	1	1		1		3
1000	GSXR1000R L7 - L8 ABS	2017-2019	HBK7020	Set Up OEM anteriore	3			3		6
1100	GSX1100 EE - EG	1984-1988	HBK7205	Set Up OEM anteriore	1	2		1		4
1100	GSX1100 ESD	1983-1985	HBK7207	Set Up OEM anteriore	1	2	2	1		6
1100	GSX1100 ET - EX	1980-1981	HBK7210	Set Up OEM anteriore	1	2		1		4
1100	GSX1100 EZ - SZ Katana	1982	HBK7212	Set Up OEM anteriore	1	2	2	1		6
1100	GSX1100 FJ - FR Sports Tourer Power Screen	1988-1994	HBK7213	Set Up OEM anteriore	1	2		1		4
1100	GSX1100 GM - GN	1991-1994	HBK7782	Set Up OEM anteriore	1	1	1	1		4
1100	GSX1100 SD	1983	HBK7783	Set Up OEM anteriore	1	2	2	1		6
1100	GSX1100F	1988-1994	HBK7213	Linea frizione					1	1
1100	GSXR1100 G - J	1986-1988	HBK7316	Linea frizione					1	1
1100	GSXR1100 G - H	1986-1987	HBK7662	Set Up RACE	1	1		1		3
1100	GSXR1100 G - H	1986-1987	HBK7316	Set Up OEM anteriore	1	2		1		4
1100	GSXR1100 J	1988	HBK7320	Set Up RACE	1	1		1		3
1100	GSXR1100 J	1988	HBK7319	Set Up OEM anteriore	1	2		1		4
1100	GSXR1100 K	1989	HBK7788	Set Up RACE	1	1		1		3
1100	GSXR1100 K	1989	HBK7321	Set Up OEM anteriore	1	2		1		4
1100	GSXR1100 K - N Slingshot	1989-1992	HBK7321	Linea frizione					1	1
1100	GSXR1100 L	1990	HBK7323	Set Up RACE	1	1		1		3
1100	GSXR1100 L	1990	HBK7322	Set Up OEM anteriore	1	2		1		4
1100	GSXR1100 M	1991	HBK7825	Set Up RACE	1	1		1		3
1100	GSXR1100 M	1991	HBK7324	Set Up OEM anteriore	1	2		1		4
1100	GSXR1100 N	1992	HBK7789	Set Up RACE	1	1		1		3
1100	GSXR1100 N	1992	HBK7325	Set Up OEM anteriore	1	2		1		4
1100	GSXR1100 WP - WT	1993-1996	HBK7326	Linea frizione					1	1
1100	GSXR1100 WP - WT	1993-1996	HBK7326	Set Up RACE	1	1		1		3
1100	GSXR1100 WP - WT	1993-1996	HBK7327	Set Up sopra parafango anteriore	1	1		1		3
1200	GS1200SS (Japan only model)	2001-2002	HBK7038	Set Up OEM anteriore	1	2		1		4
1200	GSF1200 K1 - K5 Bandit	2001-2005	HBK7621	Linea frizione					1	1
1200	GSF1200 K1 - K5 Bandit	2001-2005	HBK7621	Set Up RACE	1	1		1		3
1200	GSF1200 K1 - K5 Bandit	2001-2005	HBK7622	Set Up OEM anteriore	1	2		1		4
1200	GSF1200 K6 Bandit	2006-2006	HBK7722	Linea frizione					1	1
1200	GSF1200 K6 Bandit	2006-2006	HBK7722	Set Up sopra parafango anteriore	1	1		1		3
1200	GSF1200 K6 Bandit	2006-2006	HBK7723	Set Up RACE	1	1		1		3

CILIND.	MODELLO	ANNI	CODICE	CONFIGURAZIONE	ANT. SUP.	ANT. INF.	AGG.	POST.	FRIZ.	TOT. TUBI
1200	GSF1200 K6 Bandit ABS	2006-2006	HBK7725	Set Up OEM anteriore	7					7
1200	GSF1200 T - Y Bandit	1996-2000	HBK7145	Set Up RACE	1	1		1		3
1200	GSF1200 T - Y Bandit	1996-2000	HBK7152	Set Up OEM anteriore	1	2		1		4
1200	GSF1200 T-Y Bandit	1996-2000	HBC7145	Linea frizione					1	1
1200	GSX1200 Inazuma	1999-2000	HBC7805	Linea frizione					1	1
1200	GSX1200 Inazuma	1999-2000	HBK7806	Set Up RACE	1	1		1		3
1200	GSX1200 Inazuma	1999-2000	HBK7805	Set Up OEM anteriore	1	2		1		4
1200	GSF1200 Bandit Cam 4 Line Kit	1996-2005	HBK7142		1	1	1	1		4
1200	GSF1200 Bandit Cam 2 Line Kit	1996-2005	HBK7143		1	1				2
1200	GSF1200 Bandit Cam 3 Line Kit	1996-2005	HBK7144		1	1	1			3
1200	GSF1200 T - Y Bandit	1996-2000	HBK7153	Set Up sopra parafango anteriore	1	1		1		3
1250	GSF1250 K7 - L1 Bandit	2007-2011	HBK7740	Set Up sopra parafango anteriore	1	1		1		3
1250	GSF1250 K7 - L1 Bandit	2007-2011	HBK7741	Set Up RACE	1	1		1		3
1250	GSF1250 SA ABS Bandit	2007-2011	HBC7743	Linea frizione					1	1
1250	GSF1250 SA ABS K7 - L1 Bandit	2007-2011	HBK7743	Set Up OEM anteriore	7					7
1250	GSX1250FA L0-L6 ABS	2010-2016	HBC7837	Linea frizione					1	1
1250	GSX1250FA L0-L6 ABS	2010-2016	HBK7837	Set Up OEM anteriore	7					7
1250	GSF1250 SA ABS K7 - L1 Bandit Rear (replaces the metal pipes on rear only as well as the rubber ones)	2007-2011	HBR7742	Set Up OEM anteriore			1	1		2
1250	GSF1250 SA ABS K7 - L1 Bandit Standard Rears	2007-2011	HBR7743	Set Up OEM anteriore			1	1		2
1300	GSX1300 B-King	2008-2012	HBC7757	Linea frizione					1	1
1300	GSX1300 B-King	2008-2012	HBK7756	Set Up sopra parafango anteriore	1	1		1		3
1300	GSX1300 B-King	2008-2012	HBK7757	Set Up RACE	1	1		1		3
1300	GSX1300R ABS L3- L5 Hayabusa	2013-2018	HBK7786	Set Up OEM anteriore	3			2		5
1300	GSX1300R Hayabusa K8 - L2	2008-2012	HBC7767	Linea frizione					1	1
1300	GSX1300R K8 - L2 Hayabusa	2008-2014	HBK7766	Set Up sopra parafango anteriore	1	1		1		3
1300	GSX1300R K8 - L2 Hayabusa	2008-2014	HBK7767	Set Up RACE	1	1		1		3
1300	GSX1300R L3-L5 Hayabusa	2013-2018	HBC7768	Linea frizione					1	1
1300	GSX1300R RX - K3 / RZ Hayabusa	1999-2007	HBC7766	Linea frizione					1	1
1300	GSX1300R RX - K7 Hayabusa	1999-2007	HBK7336	Set Up OEM anteriore	1	1		1		3
1300	GSX1300R RX - K7 Hayabusa	1999-2007	HBK7604	Set Up RACE	1	1		1		3
1400	GSX1400 K1 - K8	2001-2008	HBC7221	Linea frizione					1	1
1400	GSX1400 K1 - K8	2001-2008	HBK7222	Set Up RACE	1	1		1		3
1400	GSX1400 K1 - K8	2001-2008	HBK7221	Set Up OEM anteriore	1	2		1		4
1400	VS1400 GLPH - GLPV Intruder	1987-1999	HBC7537	Linea frizione					1	1
1400	VS1400 GLPH - GLPV Intruder	1987-2004	HBK7538	Set Up OEM anteriore	1			1		2
1400	VS1400 Intruder GLP H-K4 (Flat bars)	1987-2004	HBK7537	Set Up OEM anteriore	1			1		2
1500	M90 Boulevard / Intruder	2011	HBK7823	Set Up OEM anteriore	1	1		1		3
1500	M90 Boulevard / Intruder	2011	HBK7824	Set Up sopra parafango anteriore	1	1		1		3
1500	VL1500 LC Intruder	1998-2004	HBC7713	Linea frizione					1	1

CILIND.	MODELLO	ANNI	CODICE	CONFIGURAZIONE	ANT. SUP.	ANT. INF.	AGG.	POST.	FRIZ.	TOT. TUBI
1500	VL1500 LC Intruder (Single Front Disc)	1998-2001	HBK7713	Set Up OEM anteriore	1			1		2
1500	VL1500 LC Intruder (Twin Disc)	2002-2004	HBK7710	Set Up OEM anteriore	1	1		1		3
1600	M1600 Boulevard	2004-2005	HBK7698	Set Up OEM anteriore	1	1	1			3
1600	VS1600 Intruder	2004-2005	HBK7697	Set Up OEM anteriore	1					1
1600	VZ1600 Marauder	2004-2005	HBK7677	Linea frizione					1	1
1600	VZ1600 Marauder	2004-2005	HBK7678	Set Up RACE	1	1		1		3
1600	VZ1600 Marauder	2004-2005	HBK7677	Set Up OEM anteriore	1	2		1		4
1800	M1800R Intruder	2006-2008	HBK7733	Set Up RACE	1	1		1		3
1800	M1800R Intruder	2006-2008	HBK7755	Set Up OEM anteriore	1	2		1		4
1800	VZR1800 Intruder	2012-2015	HBK7832	Set Up OEM anteriore	1	1	1	1		4
1800	VZR1800 M109R Boulevard	2006-2008	HBK7732	Set Up RACE	1	1		1		3
1800	VZR1800 M109R Boulevard	2006-2008	HBK7755	Set Up OEM anteriore	1	2		1		4
1800	VLR1800 (E2 only) K8-L1	2008-2011	HBK7023	Set Up OEM anteriore	6			4		10
	GP100 X - ED	1981-1991	HBK7045	Set Up OEM anteriore	1					1
	GT185 K - C	1973-1978	HBK7394	Set Up OEM anteriore	1					1
	Volty Import	1997-2000	HBK7793	Set Up OEM anteriore	1					1
	M1800R Intruder	2006-2008	HBK7018	Set Up OEM anteriore	1	2		1		4
	DR650R SEP DO NOT USE - CUSTOMER COMPLAINT REGARDING INCORRECT SPEC	1991-1994	HBK7691	Set Up OEM anteriore	1	1		1		3
	GT550 L-M	1974-1975	HBK7754	Set Up OEM anteriore	1	1				2
	Goose 350	1991-1996	HBK7774	Set Up OEM anteriore	1			1		2
TEMA										
	Motocross / Enduro	2002	HBK7900	Set Up OEM anteriore	1					1
	Motocross Enduro	2002	HBK7950	Linea frizione					1	1
TM										
250	250 EN	2003-2008	HBK7976	Linea frizione					1	1
	Motocross	2002	HBK7925	Set Up OEM anteriore	1			1		2
	Motorcross	2002	HBK7975	Linea frizione					1	1
TRAXX										
110	Sky 110	2010	HBK7950	Set Up OEM anteriore	1					1
125	Fly 125	2010	HBK7952	Set Up OEM anteriore	1			1		2
250	Shark 250	2010	HBK7953	Set Up OEM anteriore	1					1
	Joto 125	2010	HBK7951	Set Up OEM anteriore	1					1
TRIUMPH										
600	Daytona 600	2003-2005	HBK8132	Set Up RACE	1	1		1		3
600	Daytona 600	2003-2005	HBK8164	Set Up sopra parafango anteriore	1	1		1		3
600	Speed Four 600	2002-2005	HBK8144	Set Up sopra parafango anteriore	1	1		1		3
600	Speed Four 600	2002-2005	HBK8145	Set Up RACE	1	1		1		3
600	TT600	2000-2003	HBK8129	Set Up sopra parafango anteriore	1	1		1		3
600	TT600	2000-2003	HBK8130	Set Up RACE	1	1		1		3
675	Daytona 675	2006-2008	HBK8142	Set Up sopra parafango anteriore	1	1		1		3
675	Daytona 675	2006-2008	HBK8143	Set Up RACE	1	1		1		3
675	Daytona 675	2009-2010	HBK8172	Set Up sopra parafango anteriore	1	1		1		3

CILIND.	MODELLO	ANNI	CODICE	CONFIGURAZIONE	ANT. SUP.	ANT. INF.	AGG.	POST.	FRIZ.	TOT. TUBI
675	Daytona 675	2009-2010	HBK8173	Set Up RACE	1	1		1		3
675	Daytona 675R	2011-2014	HBK8176	Set Up RACE	1	1		1		3
675	Street Triple 675	2013	HBK8185	Set Up RACE	1	1		1		3
675	Street Triple 675	2013	HBK8186	Set Up sopra parafango anteriore	1	1		1		3
675	Street Triple 675	2007-2012	HBK8151	Set Up sopra parafango anteriore	1	1		1		3
675	Street Triple 675	2007-2012	HBK8152	Set Up RACE	1	1		1		3
675	Street Triple R 675	2010-2011	HBK8179	Set Up sopra parafango anteriore	1	1		1		3
675	Street Triple R 675	2010-2011	HBK8180	Set Up RACE	1	1		1		3
675	Daytona 675R ABS	2013-2017	HBK8027	Set Up OEM anteriore	4			2		6
750	Bonneville 750 Low Bar	1986	HBK8012	Set Up OEM anteriore	1	1		1		3
750	Daytona 750	1992-1993	HBK8181	Set Up OEM anteriore	1	2		1		4
750	Speed Triple 750	1997	HBK8184	Set Up OEM anteriore	1	2		1		4
765	Street Triple 765 RS ABS	2019-2020	HBK8029	Set Up OEM anteriore	1	1	1	1		4
800	Bonneville T100	2000-2006	HBK8146	Set Up OEM anteriore	1			1		2
800	Tiger 800	2010-2014	HBK8187	Set Up sopra parafango anteriore	1	1		1		3
800	Tiger 800	2010-2014	HBK8188	Set Up RACE	1	1		1		3
800	Tiger 800 XC	2011	HBK8183	Set Up sopra parafango anteriore	1	1		1		3
865	America	2004-2007	HBK8140	Set Up OEM anteriore	1			1		2
865	America	2008-2009	HBK8155	Set Up OEM anteriore	1			1		2
865	Bonneville T100	2007-2010	HBK8158	Set Up OEM anteriore	1			1		2
865	Bonneville T100	2011-2016	HBK8200	Set Up OEM anteriore	1			1		2
865	Bonneville T100 SE Mag Wheel	2010-2014	HBK8001	Set Up OEM anteriore	1			1		2
865	Speedmaster	2000-2002	HBK8139	Set Up OEM anteriore	1			1		2
865	Speedmaster	2003-2010	HBK8162	Set Up OEM anteriore	1	1		1		3
865	Speedmaster	2003-2010	HBK8163	Set Up RACE	1	1		1		3
900	Adventurer Thunderbird 900	1995-2003	HBK8169	Set Up OEM anteriore	1			1		2
900	Adventurer Thunderbird Sport 900	1995-2003	HBK8085	Set Up OEM anteriore	1			1		2
900	Bonneville 900 Scrambler	2004-2007	HBK8150	Set Up OEM anteriore	1			1		2
900	Daytona 900	1991-1996	HBK8013	Linea frizione					1	1
900	Daytona 900	1992-1997	HBK8013	Set Up OEM anteriore	1	2		1		4
900	Legend TT	1998-2001	HBK8136	Set Up OEM anteriore	1			1		2
900	Scrambler 900	2008-2016	HBK8157	Set Up OEM anteriore	1			1		2
900	Speed Triple	1994-1996	HBK8015	Linea frizione					1	1
900	Speed Triple	1994-1996	HBK8015	Set Up OEM anteriore	1	2		1		4
900	Speed Triple T509	1997-2007	HBK8081	Set Up sopra parafango anteriore	1	1		1		3
900	Speed Triple T509	1997-2007	HBK8082	Set Up RACE	1	1		1		3
900	Sprint 900	1993-1997	HBK8056	Set Up OEM anteriore	1	2		1		4
900	Sprint Executive	1998-2003	HBK8141	Set Up RACE	1	1		1		3
900	Sprint Executive	1998-2003	HBK8165	Set Up OEM anteriore	1	2		1		4
900	Sprint RS	1999-2004	HBK8133	Set Up sopra parafango anteriore	1	1		1		3
900	Sprint RS	1999-2004	HBK8134	Set Up RACE	1	1		1		3
900	Sprint Sport	1998-2003	HBK8091	Set Up sopra parafango anteriore	1	1		1		3
900	Thruxton 900	2008	HBK8156	Set Up OEM anteriore	1			1		2

CILIND.	MODELLO	ANNI	CODICE	CONFIGURAZIONE	ANT. SUP.	ANT. INF.	AGG.	POST.	FRIZ.	TOT. TUBI
900	Thunderbird 900	1995-2000	HBC8131	Linea frizione					1	1
900	Thunderbird 900	1995-2003	HBK8000	Set Up OEM anteriore	1			1		2
900	Thunderbird Sport 900	1997-2004	HBK8003	Set Up OEM anteriore	1	2		1		4
900	Tiger 900	1993-2000	HBC8024	Linea frizione					1	1
900	Tiger 900	1993-2000	HBK8025	Set Up RACE	1	1		1		3
900	Tiger 900	1993-2000	HBK8024	Set Up OEM anteriore	1	2		1		4
900	Trident 900	1991	HBK8041	Set Up RACE	1	1		1		3
900	Trident 900	1991	HBK8040	Set Up OEM anteriore	1	2		1		4
900	Trident 900	1992-1998	HBC8040	Linea frizione					1	1
900	Trident 900	1992-1998	HBK8043	Set Up RACE	1	1		1		3
900	Trident 900	1992-1998	HBK8042	Set Up OEM anteriore	1	2		1		4
900	Trident Sprint Sports	1996	HBC8060	Linea frizione					1	1
900	Trident Sprint Sports	1996	HBK8060	Set Up OEM anteriore	1	2		1		4
900	Trophy 900	1991-2002	HBC8063	Linea frizione					1	1
900	Trophy 900	1991-2002	HBK8064	Set Up RACE	1	1		1		3
900	Trophy 900	1991-2002	HBK8174	Set Up sopra parafango anteriore	1	1		1		3
900	Trophy 900	1991-2002	HBK8063	Set Up OEM anteriore	1	2		1		4
900	Street Twin ABS	2016-2018	HBK8009	Set Up OEM anteriore	3			2		5
900	Bonneville Thruxton	2004-2010	HBK8149	Set Up OEM anteriore	1			1		2
955	Daytona 955i	2001-2004	HBK8006	Set Up RACE	1	1		1		3
955	Daytona 955i	2001-2004	HBK8007	Set Up sopra parafango anteriore	1	1		1		3
955	Daytona 955i	2005-2007	HBK8148	Set Up RACE	1	1		1		3
955	Daytona T595 (955i Daytona)	1997-2000	HBK8004	Set Up RACE	1	1		1		3
955	Daytona T595 (955i Daytona)	1997-2000	HBK8005	Set Up sopra parafango anteriore	1	1		1		3
955	Speed Triple 955i	2002-2003	HBK8168	Set Up sopra parafango anteriore	1	1		1		3
955	Speed Triple 955i	2002-2003	HBK8175	Set Up RACE	1	1		1		3
955	Sprint ST	1998-2004	HBK8092	Set Up sopra parafango anteriore	1	1		1		3
955	Sprint ST	1998-2004	HBK8135	Set Up RACE	1	1		1		3
955	Tiger 955	2001-2004	HBK8127	Set Up RACE	1	1		1		3
955	Tiger 955	2000-2003	HBK8128	Set Up sopra parafango anteriore	1	1		1		3
955	Tiger 955i	2005-2006	HBK8166	Set Up RACE	1	1		1		3
955	Tiger 955i	2005-2006	HBK8167	Set Up sopra parafango anteriore	1	1		1		3
1000	Daytona 1000	1992-1993	HBK8182	Set Up OEM anteriore	1	2		1		4
1050	Speed Triple 1050	2005-2010	HBK8171	Set Up RACE	1	1		1		3
1050	Speed Triple 1050	2005-2010	HBK8159	Set Up OEM anteriore	1	1	1	1		4
1050	Sprint ST 1050	2005-2010	HBK8153	Set Up sopra parafango anteriore	1	1		1		3
1050	Sprint ST 1050	2005-2010	HBK8154	Set Up RACE	1	1		1		3
1050	Sprint ST 1050 ABS	2005-2010	HBK8010	Set Up OEM anteriore	1	1	1	1		5
1050	Tiger 1050	2007-2009	HBK8002	Set Up OEM anteriore	1	1	1	1		4
1050	Tiger 1050	2010-2011	HBK8008	Set Up OEM anteriore	1	1	1	1		4
1200	Daytona 1200	1992-1997	HBK8126	Set Up OEM anteriore	1	2		1		4
1200	Tiger Explorer XC1200 ABS	2012-2015	HBK8028	Set Up OEM anteriore	4			2		5
1200	Trophy 1200	1991-2002	HBC8063	Linea frizione					1	1
1200	Trophy 1200	1991-2002	HBK8064	Set Up RACE	1	1		1		3

CILIND.	MODELLO	ANNI	CODICE	CONFIGURAZIONE	ANT. SUP.	ANT. INF.	AGG.	POST.	FRIZ.	TOT. TUBI
1200	Trophy 1200	1991-2002	HBK8174	Set Up sopra parafrangente anteriore	1	1		1		3
1200	Trophy 1200	1991-2002	HBK8063	Set Up OEM anteriore	1	2		1		4
2300	Rocket III	2004-2010	HBK8138	Set Up RACE	1	1		1		3
2300	Rocket III	2004-2010	HBK8137	Set Up OEM anteriore	1	1	1	1		4
2300	Rocket III ABS Roadster	2011-2013	HBK8014	Set Up OEM anteriore	4			2		6
	T140 D US Specification	1979	HBK8018	Set Up OEM anteriore	1	2		1		4
	T140 E US Specification	1980	HBK8019	Set Up OEM anteriore	1	1		1		3
	T140 V	1975	HBK8020	Set Up OEM anteriore	1	1		1		3
	T140 V	1978	HBK8021	Set Up OEM anteriore	1	1		1		3
	T160 V	1975	HBK8022	Set Up OEM anteriore	1	2		1		4
	TSS Electro / Bonneville Low Bar		HBK8023	Set Up OEM anteriore	1	2		1		4
	T140 E UK Specification	1979	HBK8026	Set Up OEM anteriore	1	1	1			3
	TSX 4		HBK8079	Set Up OEM anteriore	1	1		1		3
	TSX 8		HBK8080	Set Up OEM anteriore	1	1		1		3
VESPA										
300	GTS 300 Super Sport	2012-2014	HBK8501	Set Up OEM anteriore	1			1		2
	Douglas	1991	HBK8500	Set Up OEM anteriore	1					1
YAMAHA										
50	BWS NG B-Whizz	1999-2005	HBK9637	Set Up OEM anteriore	1					1
50	CW50 BWS B-Whizz	1999-2004	HBK9638	Set Up OEM anteriore	1					1
50	DT50	2004-2013	HBK9776	Set Up OEM anteriore	1					1
50	Neos	2004-2009	HBK9740	Set Up OEM anteriore	1					1
50	YQ50 Aerox	1998-2003	HBK9613	Set Up OEM anteriore	1			1		2
50	YSR50	1980	HBK9062	Set Up OEM anteriore	1					1
65	YZ65	2018-2021	HBK9021	Set Up OEM anteriore	1			1		2
80	DT80 LC2	1990-1992	HBK9022	Set Up OEM anteriore	1					1
85	YZ85	2001-2010	HBK9498	Set Up OEM anteriore	1			1		2
100	RS100	2004	HBK9653	Set Up OEM anteriore	1					1
125	DT125 R	1988-2003	HBK9025	Set Up OEM anteriore	1			1		2
125	DT125 X - SM	2004-2007	HBK9705	Set Up OEM anteriore	1			1		2
125	MT125	2015-2016	HBK9008	Set Up OEM anteriore	1			1		2
125	NXC125 Cygnus X	2004-2008	HBK9654	Set Up OEM anteriore	1					1
125	Quad : YFM125	2011-2012	HBK9769	Set Up OEM anteriore	1	1	1	1		4
125	RD125 LC	1982-1989	HBK9132	Set Up OEM anteriore	1					1
125	RDZ125		HBK9747	Set Up OEM anteriore	1					1
125	TDR125	1993-1997	HBK9651	Set Up OEM anteriore	1					1
125	TZ125		HBK9726	Set Up OEM anteriore	1					1
125	TZR125	1987-1990	HBK9233	Set Up OEM anteriore	1			1		2
125	TZR125	1991-1997	HBK9764	Set Up OEM anteriore	1			1		2
125	TZR125 Belgarda (Brembo)	1987-1992	HBK9234	Set Up OEM anteriore	1			1		2
125	WR125R	2008-2009	HBK9760	Set Up RACE	1			1		2
125	WR125X	2008-2009	HBK9766	Set Up OEM anteriore	1			1		2
125	WR125X	2010-2014	HBK9783	Set Up OEM anteriore	1			1		2
125	X-Max 125	2006-2008	HBK9698	Set Up OEM anteriore	1			1		2
125	X-MAX 125	2014-2016	HBK9102	Set Up OEM anteriore	1			1		2
125	XT125	1982-1985	HBK9372	Set Up OEM anteriore	1					1
125	XT125	2005-2008	HBK9017	Set Up OEM anteriore	1			1		2

CILIND.	MODELLO	ANNI	CODICE	CONFIGURAZIONE	ANT. SUP.	ANT. INF.	AGG.	POST.	FRIZ.	TOT. TUBI
125	XTZ125 E	2006-2010	HBF9741	Set Up OEM anteriore	1					1
125	XV125 S Virago	1997-2001	HBF9730	Set Up OEM anteriore	1					1
125	YBR125	2008	HBF9718	Set Up OEM anteriore	1					1
125	YBR125	2006-2010	HBF9680	Set Up OEM anteriore	1					1
125	YBR125 Custom	2008	HBF9717	Set Up OEM anteriore	1					1
125	YBR125 ED	2006-2010	HBF9680	Set Up OEM anteriore	1					1
125	YP125R Majesty	1999-2007	HBF9655	Set Up OEM anteriore	1					1
125	YZ125	1998-2004	HBK9493	Set Up OEM anteriore	1			1		2
125	YZ125	2005-2010	HBK9650	Set Up OEM anteriore	1			1		2
125	YZF-R125	2008-2013	HBK9719	Set Up OEM anteriore	1			1		2
125	YZF-R125	2014-2015	HBK9722	Set Up OEM anteriore	1			1		2
125	YZF-R125 ABS	2015-2018	HBK9020	Set Up OEM anteriore	2			2		4
125	YZF-R125 ABS	2019-2021	HBK9032	Set Up OEM anteriore	4			4		8
125	MT125A ABS	2015-2019	HBK9011	Set Up OEM anteriore	2			2		4
180	DTN / DTZ 180	1985-1991	HBF9745	Set Up OEM anteriore	1					1
180	TDR180		HBF9749	Set Up OEM anteriore	1					1
180	RX180	1980-1985	HBF9748	Set Up OEM anteriore	1					1
200	DT200	1980-2010	HBK9746	Set Up OEM anteriore	1			1		2
200	Quad : YFZ200 Blaster	2003-2004	HBK9635	Set Up RACE	1	1		1		3
200	Quad : YFZ200 Blaster	2005-2006	HBK9690	Set Up OEM anteriore	1	1	1	1		4
200	RD200	1978-1983	HBF9139	Set Up OEM anteriore	1					1
200	SDR200 Import	1987-1990	HBK9190	Set Up OEM anteriore	1			1		2
225	XT225	1980-1990	HBF9641	Set Up OEM anteriore	1					1
225	XT225 Serow	1996-2007	HBK9030	Set Up OEM anteriore	1			1		2
250	Quad : YFM250	2011-2012	HBK9770	Set Up OEM anteriore	1	1	1	1		4
250	R1-Z 250 2 Stroke	1990-1991	HBK9520	Set Up RACE	1	1		1		3
250	RD250 C	1976	HBF9152	Set Up OEM anteriore	1					1
250	RD250 D	1977	HBK9153	Set Up OEM anteriore	1			1		2
250	RD250 DX	1977	HBF9154	Set Up OEM anteriore	1					1
250	RD250 DXD	1977	HBF9155	Set Up OEM anteriore	1					1
250	RD250 E	1978	HBK9156	Set Up OEM anteriore	1			1		2
250	RD250 F	1979	HBK9157	Set Up OEM anteriore	1			1		2
250	RD250 LC	1980-1983	HBF9158	Set Up OEM anteriore	1					1
250	RZ250	1983-1984	HBK9708	Set Up OEM anteriore	1	2		1		4
250	SR250	1980-1996	HBF9194	Set Up OEM anteriore	1					1
250	SRV250		HBF9707	Set Up OEM anteriore	1					1
250	TDR250	1988-1992	HBK9216	Set Up OEM anteriore	1			1		2
250	TTR250	1994	HBK9609	Set Up OEM anteriore	1			1		2
250	TTR250	1995	HBF9706	Set Up OEM anteriore	1					1
250	TZ250	1980-1990	HBK9727	Set Up OEM anteriore	1	1				2
250	TZ250	1991-2000	HBK9728	Set Up OEM anteriore	1	1		1		3
250	TZR250 2MA / 1KT	1986-1990	HBK9240	Set Up OEM anteriore	1			1		2
250	TZR250 3MA (Reverse Cylinder)	1989-1990	HBK9242	Set Up OEM anteriore	1	1		1		3
250	TZR250 3XV	1991-1996	HBK9241	Set Up OEM anteriore	1	1		1		3
250	WR250	2001-2005	HBK9614	Set Up OEM anteriore	1			1		2
250	WR250F	2004	HBK9716	Set Up OEM anteriore	1			1		2
250	WR250F	2007-2008	HBK9701	Set Up OEM anteriore	1			1		2
250	WR250F (2GB3 - 2GB8)	2015-2016	HBK9023	Set Up OEM anteriore	1			1		2

CILIND.	MODELLO	ANNI	CODICE	CONFIGURAZIONE	ANT. SUP.	ANT. INF.	AGG.	POST.	FRIZ.	TOT. TUBI
250	WR250F (2GBD - B7B2)	2017-2019	HBK9016	Set Up OEM anteriore	1					1
250	WR250F Motorcross	2005-2006	HBK9647	Set Up OEM anteriore	1			1		2
250	WR250R	2008-2009	HBK9720	Set Up OEM anteriore	1			1		2
250	WR250X	2008-2010	HBK9723	Set Up OEM anteriore	1			1		2
250	XG250 Tricker	2005-2016	HBK9007	Set Up OEM anteriore	1			1		2
250	X-Max 250	2006-2008	HBK9676	Set Up OEM anteriore	1			1		2
250	X-Max 250	2007-2008	HBK9699	Set Up OEM anteriore	1					1
250	XS250 SE	1980-1985	HBK9337	Set Up OEM anteriore	1					1
250	XT250 Serow	2004-2005	HBK9724	Set Up OEM anteriore	1			1		2
250	XTZ250 Leader	2006-2010	HBK9743	Set Up OEM anteriore	1			1		2
250	XTZ250 X	2006-2010	HBK9742	Set Up OEM anteriore	1			1		2
250	XVS250 Dragstar	2004-2005	HBK9631	Set Up OEM anteriore	1					1
250	YP250 Majesty	1996-2004	HBK9691	Set Up OEM anteriore	1					1
250	YS250 Fazer	2008-2010	HBK9744	Set Up OEM anteriore	1					1
250	YZ250	1991-1991	HBK9494	Set Up OEM anteriore	1					1
250	YZ250	1992-1995	HBK9492	Set Up OEM anteriore	1			1		2
250	YZ250	1998-2003	HBK9495	Set Up OEM anteriore	1			1		2
250	YZ250 / YZF250	2004-2010	HBK9640	Set Up OEM anteriore	1			1		2
250	YZ250 / YZF250	2004-2011	HBK9649	Set Up OEM anteriore	1			1		2
250	YZ250F YZF	2006-2008	HBK9682	Set Up OEM anteriore	1			1		2
250	YZ250F YZF	2011-2021	HBK9758	Set Up OEM anteriore	1			1		2
300	YZF-R3 ABS	2015-2017	HBK9009	Set Up OEM anteriore	4			2		6
300	YZF-R3	2016-2019	HBK90014	Set Up RACE	1			1		2
350	Quad : YFZ350 Banshee	1989-2003	HBK9633	Set Up RACE	1	1		1		3
350	Quad : YFZ350 Banshee	1989-2003	HBK9029	Set Up OEM anteriore	1	1	1	1		4
350	Quad : YFZ350X Warrior	1989-2003	HBK9618	Set Up RACE	1	1		1		3
350	RD350 LC	1980-1983	HBK9164	Set Up OEM anteriore	1	2				3
350	RD350 YPVS	1983-1985	HBK9184	Set Up OEM anteriore	1	2		1		4
350	RD350A Replacing Metal Pipe	1974	HBK9768	Set Up OEM anteriore	1	1				2
350	RD350A Retaining Metal Pipe	1974	HBK9767	Set Up OEM anteriore	1	1				2
350	TX350 E	1978	HBK9232	Set Up OEM anteriore	1			1		2
350	XT350	1985-1996	HBK9377	Set Up OEM anteriore	1					1
350	RD350 F2 YPVS	1986-1992	HBK9185	Set Up OEM anteriore	1	2		1		4
400	FZ400 Sports	1985	HBK9058	Set Up OEM anteriore	1	2		1		4
400	FZR400 Genesis Import	1985-1987	HBK9084	Set Up OEM anteriore	1	2		1		4
400	FZR400RR	1992-1996	HBK9085	Set Up RACE	1	1		1		3
400	FZR400RR	1992-1996	HBK9086	Set Up OEM anteriore	1	2		1		4
400	FZR400RR SP	1991-1992	HBK9095	Set Up OEM anteriore	1	2		1		4
400	RD400 C / D Replaces Bundy	1976-1977	HBK9612	Set Up OEM anteriore	1			1		2
400	RD400 C / D Retains Bundy	1976-1977	HBK9634	Set Up OEM anteriore	1			1		2
400	RD400 E / F	1978-1979	HBK9611	Set Up OEM anteriore	1			1		2
400	WR400	1999-2000	HBK9608	Set Up OEM anteriore	1			1		2
400	WR400	2001-2003	HBK9615	Set Up OEM anteriore	1			1		2
400	XJR400	1985-1995	HBK9773	Set Up RACE	1	1		1		3
400	XJR400	1996-2000	HBK9625	Set Up RACE	1	1		1		3
400	XR400RV	1996-2001	HBK9548	Set Up OEM anteriore	1			1		2
400	XS400 D SOHC	1976-1977	HBK9545	Set Up OEM anteriore	1			1		2
400	XS400 SE	1980-1983	HBK9343	Set Up OEM anteriore	1	1				2
400	XVS400 Dragstar	2000-2007	HBK9710	Set Up OEM anteriore	1					1

CILIND.	MODELLO	ANNI	CODICE	CONFIGURAZIONE	ANT. SUP.	ANT. INF.	AGG.	POST.	FRIZ.	TOT. TUBI
400	YP400 Majesty 400	2003-2008	HBK9681	Set Up OEM anteriore	1			1		2
400	YZ400	1999	HBK9617	Set Up OEM anteriore	1			1		2
426	WR426F	2001-2003	HBK9616	Set Up OEM anteriore	1			1		2
426	YZ426	2000-2004	HBK9496	Set Up OEM anteriore	1			1		2
450	Quad : YFZ450	2004-2006	HBK9624	Set Up RACE	1	1		1		3
450	Quad : YFZ450	2004-2006	HBK9688	Set Up OEM anteriore	1	1	1	1		4
450	Quad : YFZ450	2009-2016	HBK9692	Set Up OEM anteriore	1	1	1	1		4
450	Quad : YFZ450 - ATV Only	2004-2006	HBK9689	Set Up OEM anteriore	1	1	1	1		4
450	WR450F	2007-2008	HBK9700	Set Up OEM anteriore	1			1		2
450	WR450F Enduro	2005-2006	HBK9736	Set Up OEM anteriore	1			1		2
450	WR450F Motorcross	2005-2006	HBK9646	Set Up OEM anteriore	1			1		2
250	WR450F (1DX1 - 2GCC)	2012-2018	HBK9024	Set Up OEM anteriore	1			1		2
450	YZ450	2005-2005	HBK9648	Set Up OEM anteriore	1			1		2
450	YZ450F YZF	2006-2010	HBK9683	Set Up OEM anteriore	1			1		2
450	YZ450F YZF	2011-2021	HBK9759	Set Up OEM anteriore	1			1		2
500	KS500 C	1976	HBK9131	Set Up OEM anteriore	1			1		2
500	RD500 LC YPVS	1984-1987	HBK9186	Set Up OEM anteriore	1	2	2	1		6
500	RVZ500R	1984-1986	HBK9187	Set Up OEM anteriore	1	2	2	1		6
500	SR500	1978-1983	HBK9195	Set Up OEM anteriore	1	1				2
500	XP500 T-Max	2000-2004	HBK9704	Set Up OEM anteriore	1			1		2
500	XP500 T-Max	2004-2007	HBK9677	Set Up OEM anteriore	1	1	1	1		4
500	XS500 C	1976	HBK9349	Set Up OEM anteriore	1	1				2
500	XS500 E Twin Disc Conversion	1978	HBK9739	Set Up OEM anteriore	1	2		1		4
500	XT500	1977-1983	HBK9389	Set Up OEM anteriore	1					1
530	XP500 T-Max	2008	HBK9715	Set Up OEM anteriore	1	2		1		4
530	T-Max SX-DX ABS	2018-2019	HBK90018	Set Up OEM anteriore	3	1		1		5
530	T-Max SX-DX	2018-2019	HBK90019	Set Up OEM anteriore	3			1		4
535	XV535 DX Virago	1998-2001	HBK9433	Set Up OEM anteriore	1		1			2
535	XV535 S Virago	1994-1997	HBK9437	Set Up OEM anteriore	1		1			2
535	XV535 Virago Import - Low Bar	1988-1998	HBK9441	Set Up OEM anteriore	1					1
535	XV535 Virago Import - High Bar	1988-1998	HBK9442	Set Up OEM anteriore	1					1
550	XJ550	1981-1985	HBK9267	Set Up OEM anteriore	1	2				3
550	XJ550 US Import	1985	HBK9272	Set Up OEM anteriore	1	1				2
550	XZ550	1982-1985	HBK9486	Set Up OEM anteriore	1	2				3
550	XZ550S	1984-1985	HBK9489	Set Up OEM anteriore	1	2				3
600	FZ6 Fazer S2 ABS (solo carenata)	2007-2010	HBK9693	Set Up OEM anteriore	6			2		8
600	FZ6 N Fazer	2004-2006	HBK9628	Set Up RACE	1	1		1		3
600	FZ6 N Fazer	2004-2006	HBK9629	Set Up sopra parafango anteriore	1	1		1		3
600	FZ6 N Fazer	2007-2010	HBK9756	Set Up sopra parafango anteriore	1	1		1		3
600	FZ6 N Fazer	2007-2010	HBK9757	Set Up RACE	1	1		1		3
600	FZ6 S Fazer	2004-2006	HBK9626	Set Up RACE	1	1		1		3
600	FZ6 S Fazer	2004-2006	HBK9627	Set Up sopra parafango anteriore	1	1		1		3
600	FZ6 SA Fazer ABS	2006-2007	HBK9028	Set Up OEM anteriore	6			3		9
600	FZ6 S2 Fazer	2007-2010	HBK9754	Set Up sopra parafango anteriore	1	1		1		3
600	FZ6 S2 Fazer	2007-2010	HBK9755	Set Up RACE	1	1		1		3

CILIND.	MODELLO	ANNI	CODICE	CONFIGURAZIONE	ANT. SUP.	ANT. INF.	AGG. POST.	FRIZ.	TOT. TUBI
600	FZ600 Sports	1987-1988	HBK9059	Set Up OEM anteriore	1	2	1		4
600	FZR600	1989-1990	HBK9098	Set Up RACE	1	1	1		3
600	FZR600	1989-1990	HBK9097	Set Up OEM anteriore	1	2	1		4
600	FZR600 Genesis	1991-1993	HBK9100	Set Up OEM anteriore	1	2	1		4
600	FZR600 R US Import	1994-1996	HBK9585	Set Up OEM anteriore	1	1	1		3
600	FZR600R	1994-1996	HBK9105	Set Up OEM anteriore	1	1	1		3
600	FZS600 Fazer	1998-2003	HBK9119	Set Up RACE	1	1	1		3
600	FZS600 Fazer	1998-2003	HBK9118	Set Up OEM anteriore	1	2	1		4
600	SRX600	1986-1988	HBK9200	Set Up OEM anteriore	1	2	1		4
600	TT600N	1985-1989	HBK9774	Set Up OEM anteriore	1				1
600	XJ6	2008-2009	HBK9753	Set Up RACE	1	1	1		3
600	XJ6 N	2009-2010	HBK9762	Set Up RACE	1	1	1		3
600	XJ6 N	2009-2010	HBK9763	Set Up sopra parafango anteriore	1	1	1		3
600	XJ600	1990	HBK9751	Set Up OEM anteriore	1	2			3
600	XJ600	1984-1992	HBK9273	Set Up OEM anteriore	1	2	1		4
600	XJ600 F Diversion ABS	2010-2016	HBK9005	Set Up OEM anteriore	4		1		5
600	XJ600 N	2000	HBK9775	Set Up RACE	1	1	1		3
600	XJ600 N	1994-1997	HBK9729	Set Up OEM anteriore	1		1		2
600	XJ600 N - S Diversion	1998-2003	HBK9575	Set Up RACE	1	1	1		3
600	XJ600 N Single Disc Diversion	1992-1997	HBK9282	Set Up OEM anteriore	1		1		2
600	XT600	1987-1990	HBK9711	Set Up OEM anteriore	1		1		2
600	XT600	1991-2003	HBK9657	Set Up OEM anteriore	1		1		2
600	XT600 Z Tenere	1986-1990	HBK9390	Set Up OEM anteriore	1		1		2
600	YX600 Radian	1986-1994	HBK9283	Set Up OEM anteriore	1	2			3
600	YZF600R Thundercat	1996-2002	HBK9505	Set Up OEM anteriore	1	1	1		3
600	YZF-R6	1998-2002	HBK9524	Set Up OEM anteriore	1	1	1		3
600	YZF-R6	1998-2002	HBK9525	Set Up sopra parafango anteriore	1	1	1		3
600	YZF-R6	2003-2004	HBK9566	Set Up RACE	1	1	1		3
600	YZF-R6	2005-2005	HBK9644	Set Up RACE	1	1	1		3
600	YZF-R6	2005-2005	HBK9645	Set Up sopra parafango anteriore	1	1	1		3
600	YZF-R6	2006-2016	HBK9686	Set Up RACE	1	1	1		3
600	YZF-R6 Rossi Replica	2006-2007	HBK9687	Set Up RACE	1	1	1		3
600	YZF-R6 ABS	2017-2020	HBK9026	Set Up OEM anteriore	3		2		5
600	YZF-R6	2018-2019	HBFKK0015	Set Up supersport	4		1		5
600	YZF-R6	2018-2019	HBFKK0016	Set Up RACE	2		1		3
600	YZF-R6 tipo SS	2021	HBFKK0028	Set Up RACE con sdoppiatore					4
650	XJ650	1980-1984	HBK9289	Set Up OEM anteriore	1	2			3
650	XJ650 Maxim USA Import - Single disc	1982-1984	HBK9290	Set Up OEM anteriore	1	1			2
650	XJ650 Turbo	1982-1985	HBK9294	Set Up OEM anteriore	1	2			3
650	XS650	1981-1982	HBK9351	Set Up OEM anteriore	1	2			3
650	XS650 B - **** CHECK 10x1.00mm Thread ****	1975	HBK9350	Set Up OEM anteriore	1	2			3
650	XS650 C	1975	HBK9352	Set Up OEM anteriore	1	2			3
650	XS650 E - F	1978-1980	HBK9353	Set Up OEM anteriore	1	2			3
650	XS650 II	1972	HBK9354	Set Up OEM anteriore	1				1
650	XS650 SE	1979-1982	HBK9355	Set Up OEM anteriore	1	1	1		3

CILIND.	MODELLO	ANNI	CODICE	CONFIGURAZIONE	ANT. SUP.	ANT. INF.	AGG.	POST.	FRIZ.	TOT. TUBI
650	XS650 US Import	1977	HBK9360	Set Up OEM anteriore	1	1				2
650	XVS650 Dragstar	1997-2007	HBK9459	Set Up OEM anteriore	1					1
650	XVS650A Dragstar Classic	1998-2006	HBK9464	Set Up OEM anteriore	1					1
660	MT-03	2006-2008	HBK9674	Set Up RACE	1	1		1		3
660	MT-03	2006-2008	HBK9675	Set Up OEM anteriore	1	1	1	1		4
660	Quad : YFZ660R Raptor	2000-2005	HBK9619	Set Up RACE	1	1		1		3
660	Quad : YFZ660R Raptor	2000-2005	HBK9620	Set Up OEM anteriore	1	2		1		4
660	SZR660	1996-1997	HBK9203	Set Up OEM anteriore	1			1		2
660	XT660 Z Tenere	2008-2015	HBK9721	Set Up RACE	1	1		1		3
660	XT660R	2004-2014	HBK9643	Set Up OEM anteriore	1			1		2
660	XT660X	2004-2014	HBK9630	Set Up OEM anteriore	1			1		2
660	XT660Z Tenere	1991-2003	HBK9761	Set Up OEM anteriore	1			1		2
660	XT660Z Tenere ABS	2014-2016	HBK9010	Set Up OEM anteriore	6			2		8
660	XTZ660 R	2000-2008	HBK9734	Set Up RACE	1	1		1		3
660	XTZ660 Tenere	1991-1999	HBK9397	Set Up OEM anteriore	1			1		2
700	MT-07	2013-2016	HBK9671	Set Up RACE	1	1		1		3
700	MT-07	2013-2016	HBK9673	Set Up sopra parafrangente anteriore	1	1		1		3
700	MT-07 ABS (A DATABASE)	2013-2019	HBK9685	Set Up OEM anteriore	3			4		7
700	Quad : YFM700 Raptor	2006-2008	HBK9702	Set Up OEM anteriore	1	1	1	1		4
700	Quad : YFM700 Raptor	2009-2012	HBK9004	Set Up OEM anteriore	1	1	1	1		4
700	XV700 Virago Import	1985	HBK9732	Set Up RACE	1	1				2
700	XV700 Virago Import	1985	HBK9731	Set Up OEM anteriore	1	2				3
700	Tenere 700 ABS	2019-2021	HBK9027	Set Up OEM anteriore	5			2		7
700	Tracer 700 ABS	2016-2018	HBK9012	Set Up OEM anteriore	5			2		7
700	XSR700 ABS	2015-2021	HBK9902	Set Up OEM anteriore	5			2		7
750	FZ750	1985-1986	HBK9061	Set Up OEM anteriore	1	2		1		4
750	FZ750	1985-1988	HBC9061	Linea frizione					1	1
750	FZ750	1987-1995	HBK9067	Set Up OEM anteriore	1	2		1		4
750	FZR750 Genesis	1989-1992	HBK9108	Set Up OEM anteriore	1	2		1		4
750	FZR750 R OW01	1989-1992	HBK9110	Set Up OEM anteriore	1	1		1		3
750	FZX750	1987-1989	HBC9128	Linea frizione					1	1
750	FZX750	1987-1989	HBK9128	Set Up OEM anteriore	1	2		1		4
750	XJ750 Antidive	1982-1984	HBK9298	Set Up OEM anteriore	1	2	2			5
750	XS750	1978-1979	HBK9361	Set Up OEM anteriore	1	2		1		4
750	XS750 E	1977-1978	HBK9362	Set Up OEM anteriore	1	2		1		4
750	XS750 SE	1980-1982	HBK9363	Set Up OEM anteriore	1	2		1		4
750	XTZ750 Super Tenere	1989-1996	HBK9406	Set Up OEM anteriore	1	2		1		4
750	XV750 SE	1981-1983	HBK9452	Set Up OEM anteriore	1					1
750	XV750 Virago	1992-1997	HBK9534	Set Up RACE	1	1				2
750	XV750 Virago	1992-1997	HBK9533	Set Up OEM anteriore	1	2				3
750	YZF750 SP / R	1993-1998	HBC9511	Linea frizione					1	1
750	YZF750 SP	1993-1998	HBK9511	Set Up OEM anteriore	1	1		1		3
750	YZF750R	1995-1998	HBK9532	Set Up OEM anteriore	1	1		1		3
750	YZF-R7	1999-2002	HBK9623	Set Up RACE	1	1		1		3
800	FZ8 SA-NA ABS (carenata / scarenata)	2010-2015	HBK9782	Set Up OEM anteriore	7			2		9
800	FZ8 S-N (carenata / scarenata)	2010-2015	HBK9750	Set Up RACE	1	1		1		3
850	MT-09	2013-2015	HBK9778	Set Up sopra parafrangente anteriore	1	1		1		3

CILIND.	MODELLO	ANNI	CODICE	CONFIGURAZIONE	ANT. SUP.	ANT. INF.	AGG.	POST.	FRIZ.	TOT. TUBI
850	MT-09	2013-2015	HBK9779	Set Up RACE	1	1		1		3
850	MT-09 (Inc Sport Tracker) ABS	2013-2020	HBK9780	Set Up OEM anteriore	5			2		7
850	MT-09 Tracer ABS	2015-2016	HBK9777	Set Up OEM anteriore	5			2		7
850	TDM850	1991-1995	HBK9205	Set Up OEM anteriore	1	2		1		4
850	TDM850	1996-2002	HBK9210	Set Up RACE	1	1		1		3
850	TDM850	1996-2002	HBK9211	Set Up sopra parafango anteriore	1	1		1		3
850	TDM850	1996-2002	HBK9725	Set Up OEM anteriore	1	1	1	1		4
850	TRX850	1996-2000	HBK9226	Set Up OEM anteriore	1	1		1		3
850	TRX850	1996-2000	HBK9709	Set Up sopra parafango anteriore	1	1		1		3
850	XS850	1980-1985	HBK9366	Set Up OEM anteriore	1	2		1		4
850	Niken / Niken GT RN58	2018-2020	HBK9014	Set Up OEM anteriore	6			2		8
900	TDM900 (Non ABS)	2002-2012	HBK9555	Set Up sopra parafango anteriore	1	1		1		3
900	TDM900 (Non ABS)	2002-2012	HBK9557	Set Up RACE	1	1		1		3
900	TDM900 (Non ABS)	2002-2012	HBK9556	Set Up OEM anteriore	1	1	1	1		4
900	TDM900A ABS	2005-2010	HBK9559	Set Up OEM anteriore	7			2		9
900	Tracer 900 / GT ABS	2017-2020	HBK9019	Set Up OEM anteriore	1	1	1	1		4
900	XJ900 F	1986-1991	HBK9301	Set Up OEM anteriore	1	2		1		4
900	XJ900 F	1991-1994	HBK9642	Set Up OEM anteriore	1	2		1		4
900	XJ900 S	1983-1985	HBK9315	Set Up OEM anteriore	1	2	2	1		6
900	XJ900 S Diversion	1994-1996	HBK9712	Set Up RACE	1	1		1		3
900	XJ900 S Diversion	1994-1996	HBK9735	Set Up OEM anteriore	1	1	1	1		4
900	XJ900 S Diversion	1997-2003	HBK9002	Set Up RACE	1	1		1		3
900	XJ900 S Diversion	1997-2003	HBK9003	Set Up sopra parafango anteriore	1	1		1		3
900	XJ900 S Diversion	1997-2003	HBK9001	Set Up OEM anteriore	1	1	1	1		4
900	XSR900 ABS (7 Lines)	2016-2018	HBK9901	Set Up OEM anteriore	5			2		7
900	XSR900 ABARTH ABS (7 Lines)	2017-2018	HBK9900	Set Up OEM anteriore	5			2		7
920	XV920 Import	1981	HBK9652	Set Up OEM anteriore	1	2				3
950	XV950	2013-2016	HBK9018	Set Up OEM anteriore	1			1		2
950	XV950 ABS - servono tubi originali per la replica	2014-2015	HBK9781	Set Up OEM anteriore						0
950	XVS950 Midnight Star	2009-2015	HBK9752	Set Up OEM anteriore	1			1		2
1000	FZ1 Fazer	2009-2015	HBK9120	Set Up RACE	1	1		1		3
1000	FZ1-N Fazer	2006-2010	HBK9668	Set Up RACE	1	1		1		3
1000	FZ1-NA ABS Fazer (solo scarenata)	2008-2012	HBK9116	Set Up OEM anteriore	7			2		9
1000	FZ1-S Fazer (Faired)	2006-2010	HBK9667	Set Up RACE	1	1		1		3
1000	FZ1-SA ABS Fazer (solo scarenata)	2007-2012	HBK9117	Set Up OEM anteriore	6			2		8
1000	FZR1000 EXUP	1989-1991	HBK9074	Linea frizione					1	1
1000	FZR1000 Genesis	1987-1988	HBK9072	Linea frizione					1	1
1000	FZR1000 Genesis	1987-1988	HBK9072	Set Up OEM anteriore	1	2		1		4
1000	FZR1000 RU EXUP	1991-1994	HBK9083	Set Up RACE	1	1		1		3
1000	FZR1000 RU EXUP	1991-1994	HBK9082	Set Up OEM anteriore	1	2		1		4
1000	FZR1000R EXUP	1989-1990	HBK9658	Set Up RACE	1	1		1		3
1000	FZR1000R EXUP	1989-1990	HBK9074	Set Up OEM anteriore	1	2		1		4
1000	FZR1000R EXUP	1995-1996	HBK9076	Set Up OEM anteriore	1	1		1		3
1000	FZS1000 Fazer	2001-2005	HBK9115	Set Up RACE	1	1		1		3

CILIND.	MODELLO	ANNI	CODICE	CONFIGURAZIONE	ANT. SUP.	ANT. INF.	AGG.	POST.	FRIZ.	TOT. TUBI
1000	FZS1000 Fazer	2001-2005	HBK9114	Set Up OEM anteriore	1	2		1		4
1000	GTS1000	1993-1996	HBC9733	Linea frizione					1	1
1000	GTS1000 A ABS Front	1993-1996	HBK9733	Set Up OEM anteriore	1	1	1	1		7
1000	GTS1000 A ABS Rear	1993-1996	HBR9733	Set Up OEM anteriore			1	1		2
1000	MT-10 ABS & SP Model	2016-2019	HBK9639	Set Up OEM anteriore	5			2		7
1000	XV1000 TR1	1981-1985	HBK9221	Set Up OEM anteriore	1	2				3
1000	XV1000 Virago	1986-1989	HBK9414	Set Up OEM anteriore	1	2		1		4
1000	YZF1000R Thunderace	1996-2001	HBK9499	Set Up OEM anteriore	1	1		1		3
1000	YZF1000R Thunderace	1996-2002	HBC9499	Linea frizione					1	1
1000	YZF-R1	1998-2001	HBK9516	Set Up OEM anteriore	1	1		1		3
1000	YZF-R1	1998-2001	HBK9517	Set Up sopra parafango anteriore	1	1		1		3
1000	YZF-R1	2002-2003	HBK9522	Set Up RACE	1	1		1		3
1000	YZF-R1	2004-2005	HBK9632	Set Up RACE	1	1		1		3
1000	YZF-R1	2006-2006	HBK9684	Set Up RACE	1	1		1		3
1000	YZF-R1	2007-2008	HBK9703	Set Up RACE	1	1		1		3
1000	YZF-R1	2009-2011	HBK9737	Set Up RACE	1	1		1		3
1000	YZF-R1	2012-2014	HBK9772	Set Up RACE	1	1		1		3
1000	YZF-R1 / YZF-R1M ABS	2015-2020	HBK9535	Set Up OEM anteriore	5			2		7
1000	YZF-R1 no ABS	2015-2019	HBFKK0006	Set Up SBK	4			1		5
1000	YZF-R1 no ABS	2015-2019	HBFKK0007	Set Up RACE	2			1		3
1100	BT1100 Bulldog	2003-2006	HBK9622	Set Up RACE	1	1		1		3
1100	BT1100 Bulldog	2003-2006	HBK9621	Set Up OEM anteriore	1	2		1		4
1100	FJ1100	1985-1986	HBC9038	Linea frizione					1	1
1100	FJ1100	1985-1986	HBK9038	Set Up OEM anteriore	1	2	2	1		6
1100	MT-01	2005-2012	HBC9670	Linea frizione					1	1
1100	MT-01	2005-2012	HBK9670	Set Up RACE	1	1		1		3
1100	MT-01	2005-2012	HBK9672	Set Up OEM anteriore	1	1	1	1		4
1100	XS1100	1978-1980	HBK9332	Set Up OEM anteriore	1	2		1		4
1100	XS1100 S	1981-1984	HBK9333	Set Up OEM anteriore	1	2		1		4
1100	XS1100 SG USA Import		HBK9656	Set Up OEM anteriore	1	2		1		4
1100	XV1100 Virago	1989-1999	HBK9418	Set Up OEM anteriore	1	2				3
1100	XVS1100 Dragstar (5EL1 - 5EL8)	1999-2000	HBK9015	Set Up OEM anteriore	1	1	1	1		4
1100	XVS1100 A Dragstar	2001-2008	HBK9456	Set Up OEM anteriore	1	2		1		4
1100	XVS1100 V Star (USA)	1998-2008	HBK9567	Set Up OEM anteriore	1	2		1		4
1100	XVS1100A Dragstar	1998-2008	HBK9455	Set Up RACE	1	1		1		3
1200	FJ1200 (1TX / 3CV / 3XW)	1986-1996	HBC9042	Linea frizione					1	1
1200	FJ1200 (3CV - 3XW)	1988-1996	HBK9042	Set Up OEM anteriore	1	2		1		4
1200	FJ1200 A ABS	1991-1996	HBC9046	Linea frizione					1	1
1200	FJ1200 Anti Dive	1986-1987	HBK9040	Set Up OEM anteriore	1	2	2	1		6
1200	FJ1200A ABS	1991-1996	HBK9046	Set Up OEM anteriore	8					8
1200	V-Max 1200	1985-2003	HBK9246	Set Up RACE	1	1		1		3
1200	V-Max 1200	1985-2003	HBK9245	Set Up OEM anteriore	1	2		1		4
1200	V-Max 1200	1985-2003	HBC9245	Linea frizione					1	1
1200	XJR1200	1995-1998	HBC9316	Linea frizione					1	1
1200	XJR1200	1995-1998	HBK9316	Set Up RACE	1	1		1		3
1200	XT1200Z Super Tenere ABS	2010-2015	HBK9006	Set Up OEM anteriore	5			2		7
1200	XT1200Z Super Tenere ABS	2010-2015	HBC9006	Linea frizione					1	1
1200	XVZ12TD Venture XVZ1200TD	1999-2001	HBK9468	Set Up OEM anteriore	1	1	2	1		5

CILIND.	MODELLO	ANNI	CODICE	CONFIGURAZIONE	ANT. SUP.	ANT. INF.	AGG. POST.	FRIZ.	TOT. TUBI
1300	FJR1300	2000-2005	HBC9581	Linea frizione				1	1
1300	FJR1300	2000-2005	HBK9582	Set Up RACE	1	1	1		3
1300	FJR1300	2000-2005	HBK9581	Set Up OEM anteriore	1	2	1		4
1300	FJR1300A ABS	2006-2007	HBC9662	Linea frizione				1	1
1300	FJR1300 AS ABS	2006-2007	HBC9662	Set Up OEM anteriore	6		3	2	11
1300	FJR1300A ABS	2008-2014	HBC9666	Linea frizione				1	1
1300	FJR1300A ABS	2008	HBC9666	Set Up OEM anteriore	5		2		7
1300	XJR1300	1999-2001	HBK9326	Set Up RACE	1	1	1		3
1300	XJR1300	1999-2001	HBK9320	Set Up OEM anteriore	1	2	1		4
1300	XJR1300	1999-2016	HBC9326	Linea frizione				1	1
1300	XJR1300	2002-2016	HBK9573	Set Up RACE	1	1	1		3
1300	XVS1300A Midnight Star	2006-2010	HBC9697	Set Up OEM anteriore	1	1	1	1	4
1300	XVZ1300 A Royal Star	1996-1999	HBC9476	Linea frizione				1	1
1300	XVZ1300 A Royal Star	1996-2001	HBK9476	Set Up OEM anteriore	1	2	1		4
1300	XVZ1300 AT Tour Classic	1997-2001	HBK9471	Set Up OEM anteriore	1	2	1		4
1300	XVZ1300 TF Venture Star	1998-2001	HBK9482	Set Up OEM anteriore	1	2	1		4
1600	XV1600 Road Star	1998-2002	HBK9562	Set Up OEM anteriore	1	2	1		4
1600	XV1600 Roadstar Silverado	1999-2001	HBK9558	Set Up OEM anteriore	1	2	1		4
1600	XV1600 Wild Star	1998-2004	HBK9429	Set Up OEM anteriore	1	2	1		4
1700	V-Max 1700	2009-2017	HBC9771	Linea frizione				1	1
1700	V-Max 1700 ABS	2009-2017	HBK9771	Set Up OEM anteriore	9		2		11
1700	XV1700 Road Star	2004-2005	HBK9636	Set Up OEM anteriore	1	2	1		4
1700	XV1700 Warrior	2004-2005	HBK9659	Set Up RACE	1	1	1		3
1700	XV1700 Warrior	2004-2005	HBK9660	Set Up OEM anteriore	1	1	1	1	4
1900	XV1900 Midnight Star	2006-2007	HBK9679	Set Up RACE	1	1	1		3
1900	XV1900 Midnight Star	2006-2012	HBC9738	Linea frizione				1	1
1900	XV1900 Midnight Star	2006-2012	HBK9738	Set Up OEM anteriore	1		1		2
	YZF-R15 V1.0	2012-2012	HBF9519	Set Up OEM anteriore	1				1
	YZF-R15 V2.0	2012-2013	HBK9518	Set Up OEM anteriore	1		1		2
	FS1E-DX	1983	HBF9057	Set Up OEM anteriore	1				1
	RDZ135	1991-1997	HBF9765	Set Up OEM anteriore	1				1



KAKO KAKO





CRUISE CONTROL MECCANICO, SICURO E INTUITIVO

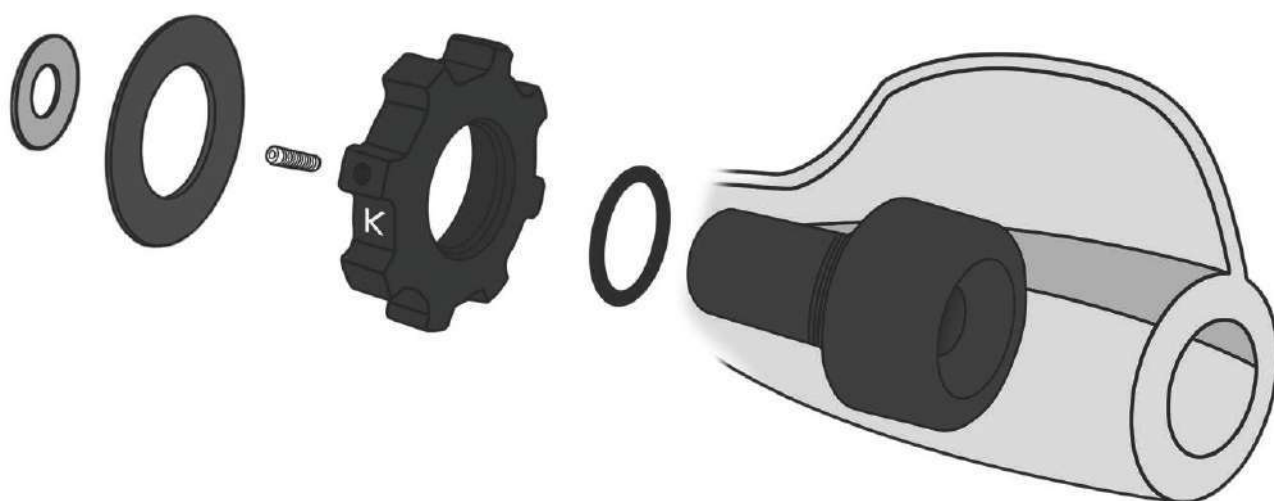

Kaoko nasce nel 2001 in Sud Africa dopo che il proprietario, Roy Mentis, durante un viaggio in Namibia, ha testato un serbatoio di grandi dimensioni di propria produzione, riscontrando allo stesso tempo un notevole affaticamento del polso per le lunghe ore in sella.

Il meccanismo prevede una **rotella dentata** che, ruotata dopo essere stata attivata, applica una resistenza alla rotazione dell'acceleratore e libera dalla tensione la mano e il polso. Allo stesso tempo **non crea alcun pericolo** perché il comando del gas rimane sempre nelle mani del pilota che può chiuderlo in un attimo con la rotazione inversa della mano. Kaoko applica solamente un attrito al comando dell'acceleratore e non lo blocca completamente. L'acceleratore può sempre essere aperto o chiuso anche quando il controllo è completamente inserito.

Lo stabilizzatore manubrio Kaoko è rinomato in tutto il mondo per la sua semplicità e per l'alta qualità. Può rendere più confortevole gli spostamenti quotidiani, infatti può essere attivato anche a bassa velocità, ed è perfetto nei viaggi lunghi quando bisogna mantenere il gas aperto per periodi di tempo estesi. Tutti i Kaoko sono **specifici** per moto e realizzati con materiali dei più alti standard ingegneristici.

Dal Sud Africa, Kaoko arriva in Italia grazie a Forbikes che è felice di curarne la distribuzione nel nostro paese.



MODELLO	NOTE	CODICE
APRILIA		
Caponord (2004-2006)	Con paramani OEM	KA-CAPO
Caponord (2014-2017)	Con paramani OEM e manopole riscaldate	KA-APR410
Caponord 1000 ETV (2007)	Con paramani OEM	KA-CAPO
Caponord 1200 ABS (2013-)	Con paramani OEM	KA-APR400
Caponord Travel Pack	Con paramani OEM	KA-APR400
Dorsoduro (2009-)	Con paramani OEM	KA-APR400
Mana 850 (2008)	Non adatto con manopole riscaldate	KA-APR300
Pegaso 650		KA-APR200
RSV1000R (2008)	Non adatto con manopole riscaldate	KA-APR300
RSV4 (2009-2017)		KA-APR500
RSV4 1100 (2019-)		KA-APR500
RSV4 RF (2018)		KA-APR500
RSV4 RR (2018)		KA-APR500
Shiver 750 (2013-)		KA-APR200
Shiver Sport ABS (2013-)		KA-APR200
SL1000 Falco (2000-)		KA-APR200
SRV 850 Scooter (2013)		KA-APR405
Trail		KA-APR200
Tuono C4 RR (2018)	Non adatto con manopole riscaldate	KA-APR300
Tuono V4 APRC ABS (2015-)	Non adatto con manopole riscaldate	KA-APR300
Tuono V4 Factory (2018)	Non adatto con manopole riscaldate	KA-APR300
BENELLI		
TRK 502 (2020-2021)	Con paramani OEM	KA-BEN100
BMW		
F800GS (2013-2020)	Anche con Barkbusters BHG040	KA-CCF500
R850R	Anche con paramani Barkbusters VPS	KA-CCF100
C1 Scooter (2000-)	Modelli con diametro di 18 mm senza terminali (EU)	KA-CCF918
C400GT (2019)	Con manopole riscaldate OEM e senza paramani	KA-CCF137
C400X (2019-2021)	Con manopole riscaldate OEM e senza paramani	KA-CCF137
C600 Evolution Scooter (2013-2019)	Con stabilizzatore nero	KA-CCF915

MODELLO	NOTE	CODICE
C600 Evolution Scooter (2013-2019)	Con stabilizzatore cromato	KA-CCF915C
C600 Sport Scooter (2013-2019)	Con stabilizzatore nero	KA-CCF915
C600 Sport Scooter (2013-2019)	Con stabilizzatore cromato	KA-CCF915C
C650 Sport	Con stabilizzatore nero	KA-CCF915
C650 Sport	Con stabilizzatore cromato	KA-CCF915C
C650GT Scooter (2013-2019)	Con stabilizzatore nero	KA-CCF915
C650GT Scooter (2013-2019)	Con stabilizzatore cromato	KA-CCF915C
F650CS Single (-2007)	Con manopole riscaldate	KA-CCF300
F650GS (-2007)	Con manopole riscaldate	KA-CCF300
F650GS (-2007)	Senza manopole riscaldate	KA-CCF300U
F650GS Dakar (-2007)	Con manopole riscaldate	KA-CCF300
F650GS Dakar Single (-2007)	Con manopole riscaldate	KA-KBB500
F650GS Dakar Single (-2007)	Senza manopole riscaldate	KA-KBB600
F650GS Single (-2007)	Con manopole riscaldate	KA-KBB500
F650GS Twin (2008-2012)	Con o senza paramani OEM in plastica	KA-CCF700
F650GS Twin (2008-2012)		KA-CCF900
F650GS Twin (2008-2012)	Barkbusters (BHG16 o BHG17)	KA-KBB700
F650GS Twin (2008-2012)	Barkbusters (BHG32)	KA-KBB700-S
F700GS (2013-2020)	Anche con Barkbusters BHG040	KA-CCF500
F700GS (2013-2020)	Con paramani Steel Backbone	KA-CCF910
F700GS (2016-)	Con o senza paramani OEM in plastica	KA-CCF136
F700GS (2016-2020)	Con stabilizzatori Barkbusters BEW35	KA-KBB320
F750GS (-2019)		KA-CCF400-13WC
F800GS (2013-2020)	Con paramani Steel Backbone	KA-CCF910
F800GS (2016-)	Con o senza paramani OEM in plastica	KA-CCF136
F800GS (2016-2020)	Con stabilizzatori Barkbusters BEW35	KA-KBB320
F800GS Adventure (2013-2020)	Anche con Barkbusters BHG040	KA-CCF500
F800GS Adventure (2013-2020)	Con paramani Steel Backbone	KA-CCF910
F800GS Adventure (2016-)	Con o senza paramani OEM in plastica	KA-CCF136
F800GS Adventure (2016-2020)	Con stabilizzatori Barkbusters BEW35	KA-KBB320
F800GS Twin (2008-2012)	Con o senza paramani OEM in plastica	KA-CCF700
F800GS Twin (2008-2012)		KA-CCF900
F800GS Twin (2008-2012)	Barkbusters (BHG16 o BHG17)	KA-KBB700
F800GS Twin (2008-2012)	Barkbusters (BHG32)	KA-KBB700-S
F800GT (2013-2019)		KA-CCF916
F800R (-2014)	Con o senza paramani OEM in plastica	KA-CCF700
F800R (2015)		KA-CCF112
F800S (2006-)	Modelli con vite svasata su terminale svasato	KA-CCF600
F800S (2006-)	Modelli con copertura su terminale svasato	KA-CCF800
F800ST (2006-)	Modelli con vite svasata su terminale svasato	KA-CCF600
F800ST (2006-)	Modelli con copertura su terminale svasato	KA-CCF800
F850GS (-2019)		KA-CCF400-13WC
F900		KA-CCF400-13WC
G310 GS (2016-2018)	Con paramani Barkbusters BHG-069	KA-KBB135
G310 GS (2016-2021)	Senza manopole riscaldate OEM in plastica	KA-CCF135
G310 HP (-2019)	Senza manopole riscaldate OEM in plastica	KA-CCF135
G310 R (2016-2018)	Con paramani Barkbusters BHG-069	KA-KBB135
G310 R (2016-2019)	Senza manopole riscaldate OEM in plastica	KA-CCF135
G650GS (-2010)	Con manopole riscaldate	KA-CCF300
G650GS (-2010)	Senza manopole riscaldate	KA-CCF300U

MODELLO	NOTE	CODICE
G650GS (-2010)	Con manopole riscaldate	KA-KBB500
G650GS (-2010)	Senza manopole riscaldate	KA-KBB600
G650GS (2011-)	Con o senza paramani OEM / Con paramani BHG45-NP	KA-CCF120
G650GS Sertao (-2010)	Senza manopole riscaldate	KA-CCF300U
G650GS Sertao (-2010)	Con manopole riscaldate	KA-KBB500
G650GS Sertao (-2010)	Senza manopole riscaldate	KA-KBB600
G650GS Sertao (2011-)	Con o senza paramani OEM / Con paramani BHG45-NP	KA-CCF120
G650X Country	Con paramani HDB Billet	KA-CCF115
Grand America (2018)		KA-CCF130C
HP2	Anche con paramani Touratech	KA-KTMADHP2
HP4 (2013-)		KA-CCF110
K1100R (1993)		KA-CCF105
K1200 S/R (-2016)	Anche con Barkbusters BHG040	KA-CCF500
K1200GT	Anche con paramani Barkbusters VPS	KA-CCF100
K1300 S/R (-2016)	Anche con Barkbusters BHG040	KA-CCF500
K1300GT	Anche con paramani Barkbusters VPS	KA-CCF100
K1600B (2018)		KA-CCF130C
K1600GT (2012-2019)		KA-CCF130
K1600GTL (2012-2019)		KA-CCF130C
K75C	Modelli con diametro di 18 mm senza terminali (EU)	KA-CCF918
R Nine T (2014-2021)		KA-CCF900
R Nine T Scrambler (2016-2018)		KA-CCF900
R100CS	Modelli con diametro di 18 mm senza terminali (EU)	KA-CCF918
R100GS (1981-)	Modelli con diametro di 18 mm senza terminali (EU)	KA-CCF918
R100S	Modelli con diametro di 18 mm senza terminali (EU)	KA-CCF918
R1100GS	Anche con paramani Barkbusters VPS	KA-CCF100
R1100R	Anche con paramani Barkbusters VPS	KA-CCF100
R1100RT	Anche con paramani Barkbusters VPS	KA-CCF100
R1100S		KA-CCF200
R1150GS	Anche con paramani Barkbusters VPS	KA-CCF100
R1150GS Adventure	Anche con paramani Barkbusters VPS	KA-CCF100
R1150R	Anche con paramani Barkbusters VPS	KA-CCF100
R1150RS (2004)	Anche con paramani Barkbusters VPS	KA-CCF100
R1150RT	Anche con paramani Barkbusters VPS	KA-CCF100
R1200 S/R (-2014)	Anche con Barkbusters BHG040	KA-CCF500
R1200C		KA-CCF600C
R1200CL		KA-CCF600C
R1200GS	Barkbusters (BHG32)	KA-KBB700-S
R1200GS (-2007)	Modelli con bullone di tenuta centrale 90 mm	KA-CCF400
R1200GS (2008-2012)	Modelli con bullone di tenuta centrale 80 mm	KA-CCF400-08
R1200GS (-2012)	Barkbusters (BHG8 o BHG12)	KA-KBB400
R1200GS Adventure	Barkbusters (BHG32)	KA-KBB700-S
R1200GS Adventure (-2007)	Modelli con bullone di tenuta centrale 90 mm	KA-CCF400
R1200GS Adventure (2008-2012)	Modelli con bullone di tenuta centrale 80 mm	KA-CCF400-08
R1200GS Adventure (-2012)	Barkbusters (BHG8 o BHG12)	KA-KBB400
R1200GS Adventure LC (2013-2019)		KA-CCF400-13WC
R1200GS LC (2013-2019)		KA-CCF400-13WC
R1200GS Rallye (2017)		KA-CCF400-13WC
R1200GS Trophy (2015-)		KA-CCF400-13WC
R1200R (-2014)	Air Cooled	KA-CCF500

MODELLO	NOTE	CODICE
R1200R (2015-2019)	Modelli a liquido	KA-CCF400-13WC
R1200RS (2015-)	Anche con Barkbusters BHG040	KA-CCF500
R1200RS (-2018)	Con o senza paramani OEM in plastica	KA-CCF136
R1200RT (-2009)	Anche con paramani Barkbusters VPS	KA-CCF100
R1200RT (2010-)	Anche con Barkbusters BHG040	KA-CCF500
R1200ST	Barkbusters (BHG8 o BHG12)	KA-KBB400
R1200ST (-2007)	Modelli con bullone di tenuta centrale 90 mm	KA-CCF400
R1200ST (2008-)	Modelli con bullone di tenuta centrale 80 mm	KA-CCF400-08
R1250GS (-2019)		KA-CCF400-13WC
R1250RS (2020-)	Con o senza paramani OEM in plastica	KA-CCF136
R1250RT (2019-)	Con o senza paramani OEM in plastica	KA-CCF136
R18 Cruiser (2020-2021)	Con manubri di altezza standard	KA-CCF138
R25	Modelli con diametro di 18 mm senza terminali (EU)	KA-CCF918
R50 (1955-)	Modelli con diametro di 16 mm senza terminali (USA)	KA-CCF917
R50 (1955-)	Modelli con diametro di 18 mm senza terminali (EU)	KA-CCF918
R60 (1955-)	Modelli con diametro di 16 mm senza terminali (USA)	KA-CCF917
R60 (1955-)	Modelli con diametro di 18 mm senza terminali (EU)	KA-CCF918
R65LS	Modelli con diametro di 18 mm senza terminali (EU)	KA-CCF918
R68	Modelli con diametro di 18 mm senza terminali (EU)	KA-CCF918
R69 (1955-)	Modelli con diametro di 18 mm senza terminali (EU)	KA-CCF918
R69S (1955-)	Modelli con diametro di 16 mm senza terminali (USA)	KA-CCF917
R69S (1955-)	Modelli con diametro di 18 mm senza terminali (EU)	KA-CCF918
R75	Modelli con diametro di 18 mm senza terminali (EU)	KA-CCF918
R80GS (1981-)	Modelli con diametro di 18 mm senza terminali (EU)	KA-CCF918
R80RT	Modelli con diametro di 18 mm senza terminali (EU)	KA-CCF918
R80ST	Modelli con diametro di 18 mm senza terminali (EU)	KA-CCF918
R850GS	Anche con paramani Barkbusters VPS	KA-CCF100
R90	Modelli con diametro di 18 mm senza terminali (EU)	KA-CCF918
R90S	Modelli con diametro di 18 mm senza terminali (EU)	KA-CCF918
S1000R (2015)		KA-CCF112
S1000RR (2010-2019)		KA-CCF110
S1000XR (2015-2020)		KA-CCF400-13WC
BUELL		
1125R (2008-)		KA-BUB
Ulysses XB12R		KA-BUB
Ulysses XB12R	Manopole Rizoma con supporti per specchietti	KA-BUB100
Ulysses XB12SS		KA-BUB
Ulysses XB12SS	Manopole Rizoma con supporti per specchietti	KA-BUB100
Ulysses XB12X		KA-BUB
Ulysses XB12X	Manopole Rizoma con supporti per specchietti	KA-BUB100
Ulysses XB12XT		KA-BUB
Ulysses XB12XT	Manopole Rizoma con supporti per specchietti	KA-BUB100
CAGIVA		
Gran Canyon (2000)		KA-CAG100
CAN-AM		
Spyder (-2012)	Con riser kit	KA-CAN100S
Spyder F3 (2013-)		KA-CAN200
Spyder F3S (2013-)		KA-CAN200
Spyder Roadster (-2012)		KA-CAN100

MODELLO	NOTE	CODICE
Spyder RS (2013-)		KA-CAN200
Spyder RT (2013-)		KA-CAN200
Spyder ST (2013-)		KA-CAN200
DUCATI		
748	Diametro interno 16,8 mm, anche con specchi CRG	KA-DUC100
848	Diametro interno 16,8 mm, anche con specchi CRG	KA-DUC100
916	Diametro interno 16,8 mm, anche con specchi CRG	KA-DUC100
996	Diametro interno 16,8 mm, anche con specchi CRG	KA-DUC100
998	Diametro interno 16,8 mm, anche con specchi CRG	KA-DUC100
999	Diametro interno 16,8 mm, anche con specchi CRG	KA-DUC100
1098	Diametro interno 16,8 mm, anche con specchi CRG	KA-DUC100
1198	Diametro interno 16,8 mm, anche con specchi CRG	KA-DUC100
1000GT Sport Classic		KA-DUCST
1100 Evo models (2008-2014)	Modelli con manubri diametro interno 14 mm	KA-DUC105
1100 Evo models (2008-2014)	Solo con specchi CRG bar-end	KA-DUC105CRG
848 Evo models (2011-2013)	Modelli con manubri diametro interno 14 mm	KA-DUC105
848 Evo models (2011-2013)	Solo con specchi CRG bar-end	KA-DUC105CRG
Diavel (2011-)		KA-DUCST
Monster 1200 (2013-)	Solo con specchi CRG bar-end	KA-DUC125CRG
Monster 1200R (2016-)		KA-DUC125REV1
Monster 1200S (2014-2019)		KA-DUC125REV1
Monster 659 ABS (-2014)	Modelli con manubri diametro interno 14 mm	KA-DUC105
Monster 659 ABS (-2014)	Solo con specchi CRG bar-end	KA-DUC105CRG
Monster 696 (2013-)	Diametro interno 16,8 mm, anche con specchi CRG	KA-DUC100
Monster 796 ABS (2010-)	Modelli con manubri diametro interno 14 mm	KA-DUC105
Monster 796 ABS (2010-)	Solo con specchi CRG bar-end	KA-DUC105CRG
Monster 937+ (2021)	Per modelli con terminali a cuneo	KA-DUC140
Monster S2		KA-DUCST
Monster S2R		KA-DUCST
Monster S4R (2004-)		KA-DUCST
Monster S4S (2004-)		KA-DUCST
Multistrada 1100 (2004-2009)		KA-DUCST
Multistrada 1100S (2004-2009)		KA-DUCST
Multistrada 1200 (2010-)	Diametro interno 16,8 mm, anche con specchi CRG	KA-DUC100
Multistrada 1200 (2010-)	Barkbusters BHG13	KA-DUC101
Multistrada 1200 Enduro (2017-)		KA-DUC125REV1
Multistrada 1200 MTS (2013)	Con paramani Ducati	KA-DUC120
Multistrada 1200S (2010-)	Diametro interno 16,8 mm, anche con specchi CRG	KA-DUC100
Multistrada 1200S (2010-)	Barkbusters BHG13	KA-DUC101
Multistrada 1260 Enduro (2017-)		KA-DUC125REV1
Multistrada 950 (2017-)	Modelli con manubri diametro interno 14 mm	KA-DUC105
Multistrada 950 (2017-)	Solo con specchi CRG bar-end	KA-DUC105CRG
Multistrada 950 (2017-)		KA-DUC125REV1
Panigale 1199 (2014)		KA-DUC110
Panigale 1299 (2016-2019)		KA-DUC110
Panigale 899 (2013-)		KA-DUC110
Panigale 959 (2016-2019)		KA-DUC110
Panigale V2 (2020)		KA-DUC110
Panigale V4 base model (2018-2021)	Per modelli con terminali a cuneo	KA-DUC140
Panigale V4S (2018)		KA-DUC110

MODELLO	NOTE	CODICE
Panigale V4S (2018-2021)	Per modelli con terminali a cuneo	KA-DUC140
S4 (2006)		KA-DUC115
Scrambler	Diametro interno 16,8 mm, anche con specchi CRG	KA-DUC100
ST2 (2000-2003)		KA-DUC115
ST3 (2005-)		KA-DUCST
ST3S (2005-)		KA-DUCST
ST4		KA-DUC115
ST4 (2005-)		KA-DUCST
ST4S (2001-2004)		KA-DUC115
ST4S (2005-)		KA-DUCST
Streetfighter	Diametro interno 16,8 mm, anche con specchi CRG	KA-DUC100
Streetfighter 848 (2007-2013)	Modelli con manubri diametro interno 14 mm	KA-DUC105
Streetfighter 848 (2007-2013)	Solo con specchi CRG bar-end	KA-DUC105CRG
Streetfighter V4 (2020)		KA-DUC125REV1
X Diavel S (2016)		KA-DUCST
HARLEY DAVIDSON		
Big Barrel Shape (Cromato)	Manubrio di serie	KA-HDBBC
Big Barrel Shape (Cromato)	Diametro interno 21 mm	KA-HDBBC-0.8
Big Barrel Shape (Nero)	Manubrio di serie	KA-HDBBB
Big Barrel Shape (Nero)	Diametro interno 21 mm	KA-HDBBB-0.8
Cannon Ball Shape (Cromato)	Manubrio di serie	KA-HDCBC
Cannon Ball Shape (Cromato)	Diametro interno 21 mm	KA-HDCBC-0.8
Cannon Ball Shape (Nero)	Manubrio di serie	KA-HDCBB
Cannon Ball Shape (Nero)	Diametro interno 21 mm	KA-HDCBB-0.8
Snubbie Shape (Nero)	Manubrio di serie	KA-HDSNUB
Snubbie Shape (Nero)	Diametro interno 21 mm	KA-HDSNUB-0.8
Torpedo Shape (Cromato)	Manubrio di serie	KA-HDTC
Torpedo Shape (Cromato)	Diametro interno 21 mm	KA-HDTC-0.8
Torpedo Shape (Nero)	Manubrio di serie	KA-HDTB
Torpedo Shape (Nero)	Diametro interno 21 mm	KA-HDTB-0.8
HONDA		
599	Solo con R&G bar-end sliders	KA-HND28R&G
CTX700 DCT (2013-)		KA-HND100
1100 Saber	Con paramani OEM e manopole riscaldate	KA-TCH-0.75
1100 Saber	Con paramani OEM e manopole riscaldate	KA-TBH-0.75
Ace Deluxe VT750	Con paramani OEM e manopole riscaldate	KA-TCH-0.75
Ace Deluxe VT750	Con paramani OEM e manopole riscaldate	KA-TBH-0.75
Africa Twin CRF1000L (2016-2020)	Con paramani OEM e manopole riscaldate	KA-HND310
Africa Twin CRF1000L (2016-2020)	Con o senza manopole riscaldate, non adatto con paramani Cycra	KA-KBB310REV1
Africa Twin CRF1100L (2020-2021)	Con paramani OEM e manopole riscaldate	KA-HND310
Africa Twin CRF1100L (2020-2021)	Con o senza manopole riscaldate, non adatto con paramani Cycra	KA-KBB310REV1
CB1000	Per modelli con terminali 30 mm	KA-HND30-17
CB1000R (2018)		KA-HND100
CB1000R Predator (2008-)	Per modelli con terminali 30 mm	KA-HND30-17
CB1100 (2017-)		KA-HND100C
CB1100 Deluxe		KA-HND100C
CB1100A (2011-)	Manubri con diametro interno superiore a 19 mm	KA-HND30-19
CB1100F (2013-)		KA-HND100
CB1300	Per modelli con terminali 30 mm	KA-HND30-17

MODELLO	NOTE	CODICE
CB500F (2013-2019)		KA-HND100
CB500X (2013-)		KA-HND100
CB500XA (2016-2021), CB500 X (2016-2021)	Barkbusters BHG-055 o BHG-081	KA-KBBHND100
CB600 Hornet (-2008)	Per modelli con terminali 28 mm	KA-HND28
CB600 Hornet (-2008)	Solo con R&G bar-end sliders	KA-HND28R&G
CB600 Hornet (2009-)	Per modelli con terminali 30 mm	KA-HND30-17
CB650F (-2017)	Per modelli con terminali 30 mm	KA-HND30-17
CB650F (-2019)		KA-HND100
CBF1000 (2008-)	Per modelli con terminali 30 mm	KA-HND30-17
CBF600	Per modelli con terminali 30 mm	KA-HND30-17
CBR1000RR (-2019)	Per modelli con terminali 28 mm	KA-HND28
CBR1000RR (-2019)	Solo con R&G bar-end sliders	KA-HND28R&G
CBR1000RR-R (2020)	Per modelli con terminali 28 mm	KA-HND28
CBR1100XX Blackbird	Terminali di diametro 31 mm (nero)	KA-HND31
CBR1100XX Blackbird	Terminali di diametro 31 mm (argento)	KA-HND31S
CBR1100XX Blackbird	Terminali di diametro 31 mm (acciaio inossidabile)	KA-HND31SS
CBR250R		KA-HND100
CBR300F (2013-)		KA-HND100
CBR300R (2013-)		KA-HND100
CBR500R (2013-2019)		KA-HND100
CBR600F	Per modelli con terminali 28 mm	KA-HND28
CBR600F4i	Manubri con diametro interno superiore a 19 mm	KA-HND30-19
CBR600RR (-2008)	Per modelli con terminali 28 mm	KA-HND28
CBR600RR (-2008)	Solo con R&G bar-end sliders	KA-HND28R&G
CBR600RR (2008-2019)	Manubri con diametro interno superiore a 19 mm	KA-HND30-19
CBR650F (2015-)	Terminali di diametro 31 mm (nero)	KA-HND31
CBR650F (2015-)	Terminali di diametro 31 mm (argento)	KA-HND31S
CBR650F (2015-)	Terminali di diametro 31 mm (acciaio inossidabile)	KA-HND31SS
CBR900RR	Terminali di diametro 31 mm (nero)	KA-HND31
CBR900RR	Terminali di diametro 31 mm (argento)	KA-HND31S
CBR900RR	Terminali di diametro 31 mm (acciaio inossidabile)	KA-HND31SS
CBX1000 (1975-1983)	Con paramani OEM e manopole riscaldate	KA-HND31S
CMX250	Con paramani OEM e manopole riscaldate	KA-TCH-0.75
CMX250	Con paramani OEM e manopole riscaldate	KA-TBH-0.75
CTX1300	Con paramani OEM e manopole riscaldate	KA-HND325
CTX700 (2013-)		KA-HND100
CTX700 N (2013-)		KA-HND100
CTX700 ND (2013-)		KA-HND100
F4i (2006)	Solo con R&G bar-end sliders	KA-HND28R&G
F6B Goldwing (2012-)	Terminali di diametro 31 mm (nero)	KA-HND31
F6B Goldwing (2012-)	Terminali di diametro 31 mm (argento)	KA-HND31S
F6B Goldwing (2012-)	Terminali di diametro 31 mm (acciaio inossidabile)	KA-HND31SS
FJS 600 Silverwing (2002-)	Con paramani OEM e manopole riscaldate	KA-HNDFJS
Integra Scooter (2012-)		KA-HND100
Interstate 1300 (2014-)	Con paramani OEM e manopole riscaldate	KA-TCH-0.8
Interstate 1300 (2014-)	Con paramani OEM e manopole riscaldate	KA-TBH-0.8
NC700 (2012-)		KA-HND100
NC700X (2012-)		KA-HND100
NC700X (2012-)	Con paramani Barkbusters	KA-KBB200REV1
NC750	Con paramani Barkbusters	KA-KBB200REV1

MODELLO	NOTE	CODICE
NC750 (2013-2016)		KA-HND100
NC750X (2018-)	Con paramani Barkbusters	KA-KBB200REV1
NM4 (2015-)	Solo con R&G bar-end sliders	KA-HND28R&G
NT700A Deauville	Con paramani OEM e manopole riscaldate	KA-HNDNT
NT700V Deauville	Con paramani OEM e manopole riscaldate	KA-HNDNT
SH300	Con paramani OEM e manopole riscaldate	KA-HNDSH
Shadow 1100	Con paramani OEM e manopole riscaldate	KA-TCH-0.8
Shadow 1100	Con paramani OEM e manopole riscaldate	KA-TBH-0.8
Shadow 750	Con paramani OEM e manopole riscaldate	KA-TCH-0.8
Shadow 750	Con paramani OEM e manopole riscaldate	KA-TBH-0.8
Shadow Aero	Con paramani OEM e manopole riscaldate	KA-TCH-0.8
Shadow Aero	Con paramani OEM e manopole riscaldate	KA-TBH-0.8
Shadow American	Con paramani OEM e manopole riscaldate	KA-TCH-0.8
Shadow American	Con paramani OEM e manopole riscaldate	KA-TBH-0.8
Shadow Sabre	Con paramani OEM e manopole riscaldate	KA-TCH-0.8
Shadow Sabre	Con paramani OEM e manopole riscaldate	KA-TBH-0.8
Spirit 1100	Con paramani OEM e manopole riscaldate	KA-TCH-0.8
Spirit 1100	Con paramani OEM e manopole riscaldate	KA-TBH-0.8
ST1100	Con paramani OEM e manopole riscaldate	KA-HNDST1100
ST1300 (2002-)	Con o senza manopole riscaldate	KA-HNDST
ST1300 Pan European (2002-)	Con o senza manopole riscaldate	KA-HNDST
Stateline 1300 (2010-)	Con paramani OEM e manopole riscaldate	KA-TCH-0.8
Stateline 1300 (2010-)	Con paramani OEM e manopole riscaldate	KA-TBH-0.8
Varadero, Africa Twin (-2003)	Con o senza manopole riscaldate Oxford	KA-HNDVARAOXF
VFR1200F (2010-)	Per modelli con terminali 28 mm	KA-HND28
VFR1200F (2010-)	Solo con R&G bar-end sliders	KA-HND28R&G
VFR1200FD (2010-)	Per modelli con terminali 28 mm	KA-HND28
VFR1200FD (2010-)	Solo con R&G bar-end sliders	KA-HND28R&G
VFR1200X (2012-)	Con paramani Barkbusters	KA-KBB200REV1
VFR1200X (2012-2016)	Con o senza paramani OEM	KA-HND200
VFR1200X Cross Tourer (2016-2017)	Con o senza paramani OEM	KA-HND200
VFR1200XD (2012-)	Con paramani Barkbusters	KA-KBB200REV1
VFR1200XD (2012-2016)	Con o senza paramani OEM	KA-HND200
VFR1200XD (2017)	Con paramani OEM e manopole riscaldate	KA-HND310
VFR750 RC36 (1993-1998)	Con paramani OEM e manopole riscaldate	KA-HND305
VFR800 (2001-)	Terminali di diametro 31 mm (nero)	KA-HND31
VFR800 (2001-)	Terminali di diametro 31 mm (argento)	KA-HND31S
VFR800 (2001-)	Terminali di diametro 31 mm (acciaio inossidabile)	KA-HND31SS
VFR800 (2014-2015)	Con manopole riscaldate Honda	KA-HND29
VFR800F (2015-)	Con manopole riscaldate Honda	KA-HND29
VFR800X Cross Runner (2011-2014)	Con paramani OEM e manopole riscaldate	KA-HND300
VFR800X Cross Runner (2015-2018)	Senza paramani OEM e con manopole riscaldate, anche per paramani GIVI	KA-HND320
VLX Deluxe VT600	Con paramani OEM e manopole riscaldate	KA-TCH-0.75
VLX Deluxe VT600	Con paramani OEM e manopole riscaldate	KA-TBH-0.75
VT1100 Shadow Spirit	Con paramani OEM e manopole riscaldate	KA-TCH-0.75
VT1100 Shadow Spirit	Con paramani OEM e manopole riscaldate	KA-TBH-0.75
VT1300	Con paramani OEM e manopole riscaldate	KA-TCH-0.8
VT1300	Con paramani OEM e manopole riscaldate	KA-TBH-0.8
VT750 C2	Con paramani OEM e manopole riscaldate	KA-TCH-0.75

MODELLO	NOTE	CODICE
VT750 C2	Con paramani OEM e manopole riscaldate	KA-TBH-0.75
VT750 C2B	Con paramani OEM e manopole riscaldate	KA-TCH-0.75
VT750 C2B	Con paramani OEM e manopole riscaldate	KA-TBH-0.75
VT750 S	Con paramani OEM e manopole riscaldate	KA-TCH-0.75
VT750 S	Con paramani OEM e manopole riscaldate	KA-TBH-0.75
VTR1000 Firestorm (1998-2008)	Terminali di diametro 31 mm (nero)	KA-HND31
VTR1000 Firestorm (1998-2008)	Terminali di diametro 31 mm (argento)	KA-HND31S
VTR1000 Firestorm (1998-2008)	Terminali di diametro 31 mm (acciaio inossidabile)	KA-HND31SS
VTX1300	Con paramani OEM e manopole riscaldate	KA-TCH-0.8
VTX1300	Con paramani OEM e manopole riscaldate	KA-TBH-0.8
VTX1800	Con paramani OEM e manopole riscaldate	KA-TCH-0.8
VTX1800	Con paramani OEM e manopole riscaldate	KA-TBH-0.8
X-ADV (2017-2019)	Con paramani OEM e manopole riscaldate	KA-HND310
X-ADV Hard Track (2017-2019)	Con paramani OEM e manopole riscaldate	KA-HND310
X-ADV Travel Edition (2017-2019)	Con paramani OEM e manopole riscaldate	KA-HND310
X-ADV X-End (2017-2019)	Con paramani OEM e manopole riscaldate	KA-HND310
XL1000V Varadero	Con paramani Barkbusters	KA-KBB200REV1
XL600V Transalp	Con paramani Barkbusters	KA-KBB200REV1
XL650V Transalp	Con paramani Barkbusters	KA-KBB200REV1
XL700V Transalp	Con paramani Barkbusters	KA-KBB200REV1
XR650L	Con paramani OEM e manopole riscaldate	KA-KTMADXR
Yamaha Super Tenere 1200 (2018-2020)	Con o senza manopole riscaldate, non adatto con paramani Cycra	KA-KBB310REV1
Yamaha Tenere 700 (2019-2020)	Con o senza manopole riscaldate, non adatto con paramani Cycra	KA-KBB310REV1
HUSQVARNA		
TR650 Terra (2013)	Con paramani Barkbusters	KA-HUS100
HYOSUNG		
GV650 Aquila, GV250 Aquila, ST7		KA-HYOS110
INDIAN		
Scout (2015-2018)	Nero	KA-INDTB100
Scout (2015-2018)	Cromato	KA-INDTC100
Scout Sixty (2018-2021)		KA-INDTB110
KAWASAKI		
650R	Adatto con paramani	KA-KAW200
650R	Senza paramani	KA-KAW221
650R	Solo con R&G bar-end sliders	KA-KAW221R&G
EN650 Vulcan (2015-)	Adatto con paramani	KA-KAW200
EN650 Vulcan (2015-)	Senza paramani	KA-KAW221
EN650 Vulcan (2015-)	Solo con R&G bar-end sliders	KA-KAW221R&G
ER-5	Adatto con paramani	KA-KAW200
ER-5	Senza paramani	KA-KAW221
ER-5		KA-KBB300
ER-5F	Solo con R&G bar-end sliders	KA-KAW221R&G
ER-6F (-2017)	Senza paramani	KA-KAW221
ER-6N	Senza paramani	KA-KAW221
ER-6N, ER-6F		KA-KBB300
ER-6N, ER-6F (-2017)	Adatto con paramani	KA-KAW200
ER-6N, ER-6F (-2017)	Solo con R&G bar-end sliders	KA-KAW221R&G
GTR1400		KA-KBB300
GTR1400 (2011-2017)	Adatto con paramani	KA-KAW200

MODELLO	NOTE	CODICE
GTR1400 (2011-2017)	Senza paramani	KA-KAW221
GTR1400 (2011-2017)	Solo con R&G bar-end sliders	KA-KAW221R&G
GTR1400 Concours	Adatto con paramani	KA-KAW200
GTR1400 Concours	Senza paramani	KA-KAW221
GTR1400 Concours	Solo con R&G bar-end sliders	KA-KAW221R&G
H2 SX SE (2020)		KA-KAW110
KLR650 (2008-2015)	Adatto con paramani	KA-KAW200
KLR650 (2008-2015)	Senza paramani	KA-KAW221
KLR650 (2008-2015)	Solo con R&G bar-end sliders	KA-KAW221R&G
KLR650 ABS (-2017)	Adatto con paramani	KA-KAW200
KLR650 ABS (-2017)	Senza paramani	KA-KAW221
KLR650 ABS (-2017)	Solo con R&G bar-end sliders	KA-KAW221R&G
KLR650E		KA-KBB300
KLR650L	Adatto con paramani	KA-KAW200
KLR650L	Senza paramani	KA-KAW221
KLR650L	Solo con R&G bar-end sliders	KA-KAW221R&G
Ninja 250		KA-KAW170
Ninja 400 (2018)	Adatto con paramani	KA-KAW200
Ninja 400 (2018)	Senza paramani	KA-KAW221
Ninja 500R (2007-2008)		KA-KAW170
Ninja 636		KA-KAW400
Ninja 650 farings (2017-2020)		KA-KAW115
Ninja 650L	Adatto con paramani	KA-KAW200
Ninja 650L	Senza paramani	KA-KAW221
Ninja 650L	Solo con R&G bar-end sliders	KA-KAW221R&G
Ninja 650R		KA-KBB300
Ninja ZX-10R (2013-2017)		KA-KAW400
Versys		KA-KBB300
Versys 300 (2017-2020)		KA-KAW115
Versys 300-X (2017-2020)	Con paramani Barkbusters	KA-KBB200REV1
Versys 1000 (2012-2019)	Adatto con paramani	KA-KAW200
Versys 1000 (2012-2019)	Senza paramani	KA-KAW221
Versys 1000 (2012-2019)	Solo con R&G bar-end sliders	KA-KAW221R&G
Versys KLE650 (-2019)	Adatto con paramani	KA-KAW200
Versys KLE650 (-2019)	Senza paramani	KA-KAW221
Versys KLE650 (-2019)	Solo con R&G bar-end sliders	KA-KAW221R&G
Versys KLE650Z (2019)	Adatto con paramani	KA-KAW200
Versys KLE650Z (2019)	Senza paramani	KA-KAW221
Versys KLE650Z (2019)	Solo con R&G bar-end sliders	KA-KAW221R&G
Vulcan 650 ABS		KA-KBB300
Vulcan 650 E		KA-KBB300
Vulcan 900 (Classic & Custom)		KA-TCK-0.75
Vulcan 900 (Classic & Custom)		KA-TBK-0.75
Vulcan Cruiser (Classic)		KA-TCK-0.75
Vulcan Cruiser (Classic)		KA-TBK-0.75
Vulcan S ABS (2015-2019)	Adatto con paramani	KA-KAW200
Vulcan S ABS (2015-2019)	Senza paramani	KA-KAW221
Vulcan S ABS (2015-2019)	Solo con R&G bar-end sliders	KA-KAW221R&G
Vulcan S Café (-2019)	Adatto con paramani	KA-KAW200
Vulcan S Café (-2019)	Senza paramani	KA-KAW221

MODELLO	NOTE	CODICE
Vulcan S Café (-2019)	Solo con R&G bar-end sliders	KA-KAW221R&G
Z1000 (-2009)		KA-KAW100
Z1000 (2010-2017)		KA-KAW170
Z1000SX (2012-2019)		KA-KAW160
Z250 (2019-)	Solo con R&G bar-end sliders	KA-KAW221R&G
Z300 (2016-)		KA-KAW170
Z400 (2019-)	Solo con R&G bar-end sliders	KA-KAW221R&G
Z650 Naked cover (2017-2020)		KA-KAW115
Z750R (-2009)		KA-KAW100
Z750S (-2009)		KA-KAW100
Z800 (2013-2017)		KA-KAW100
Z800 (2015-)		KA-KAW221CSK
Z900 (2017)	Senza paramani	KA-KAW221
Z900 (2017)	Solo con R&G bar-end sliders	KA-KAW221R&G
Z900 RS (2018-2019)	Adatto con paramani	KA-KAW200
Z900 RS (2018-2019)	Senza paramani	KA-KAW221
Z900 RS (2018-2019)	Solo con R&G bar-end sliders	KA-KAW221R&G
Z900 RS Café (-2019)	Adatto con paramani	KA-KAW200
Z900 RS Café (-2019)	Senza paramani	KA-KAW221
Z900 RS Café (-2019)	Solo con R&G bar-end sliders	KA-KAW221R&G
ZH2 (2020)		KA-KAW170
ZR1000E Naked (2013)		KA-KAW170
ZR900 (2017)	Adatto con paramani	KA-KAW200
ZR900 (2017)	Senza paramani	KA-KAW221
ZR900 (2017)	Solo con R&G bar-end sliders	KA-KAW221R&G
ZRX1200R		KA-KAW100
ZX-10 (2007-2010)		KA-KAW400
ZX-10R		KA-KAW400
ZX-10RR		KA-KAW400
ZX-12	Adatto con paramani	KA-KAW200
ZX-12	Senza paramani	KA-KAW221
ZX-12	Solo con R&G bar-end sliders	KA-KAW221R&G
ZX-12		KA-KBB300
ZX130 Scooter	Adatto con paramani	KA-KAW200
ZX130 Scooter	Senza paramani	KA-KAW221
ZX130 Scooter	Solo con R&G bar-end sliders	KA-KAW221R&G
ZX-14		KA-KBB300
ZX-14 (-2012)	Adatto con paramani	KA-KAW200
ZX-14 (-2012)	Senza paramani	KA-KAW221
ZX-14 (-2012)	Solo con R&G bar-end sliders	KA-KAW221R&G
ZX-14R (2013-2017)	Adatto con paramani	KA-KAW200
ZX-14R (2013-2017)	Senza paramani	KA-KAW221
ZX-14R (2013-2017)	Solo con R&G bar-end sliders	KA-KAW221R&G
ZX-6 (1991-1996)		KA-KAW170
ZX-6R (2016-2019)		KA-KAW170
ZX-7 (1991-1996)		KA-KAW170
ZX-7R		KA-KAW400
ZX-9		KA-KAW400
ZX-9R (-1997)		KA-KAW170
ZZR1100		KA-KAW100

MODELLO	NOTE	CODICE
ZZR1200		KA-KAW100
ZZR1400	Senza paramani	KA-KAW221
ZZR1400	Solo con R&G bar-end sliders	KA-KAW221R&G
ZZR1400		KA-KBB300
ZZR1400, ZZR1400SE	Adatto con paramani	KA-KAW200
ZZR1400SE	Senza paramani	KA-KAW221
ZZR1400SE	Solo con R&G bar-end sliders	KA-KAW221R&G
KTM		
1050 Adventure (2015-)	Paramani Barkbusters o Flexx	KA-KBBAD
1050 Adventure (2015-)		KA-KTMAD
1050 Adventure (2015-2018)	Per paramani OEM in plastica (riduce le vibrazioni del manubrio)	KA-VIBRASTOP2
1050 Adventure (2015-2018)	Per paramani OEM in plastica (riduce le vibrazioni del manubrio)	KA-VIBRASTOP2
1090 Adventure		KA-KTMAD
1090 Adventure (2017)	Paramani Barkbusters o Flexx	KA-KBBAD
1090 Adventure (-2018)	Solo con paramani Barkbusters	KA-KTMAD.BBEW
1090 Adventure R (2017)	Paramani Barkbusters o Flexx	KA-KBBAD
1090 Adventure R (-2017)		KA-KTMAD
1190 Adventure (2013-2018)	Per paramani OEM in plastica (riduce le vibrazioni del manubrio)	KA-VIBRASTOP2
1190 Adventure (2013-2018)	Per paramani OEM in plastica (riduce le vibrazioni del manubrio)	KA-VIBRASTOP2
1190 RC8		KA-KTMRC
1190 RC8R		KA-KTMRC
1290 Adventure (-2018)		KA-KTMAD
1290 Adventure (-2018)	Solo con paramani Barkbusters	KA-KTMAD.BBEW
1290 Super Adventure (-2019)	Paramani Barkbusters o Flexx	KA-KBBAD
1290 Super Adventure (-2019)		KA-KTMAD
1290 Super Duke (2014-)		KA-KTM100
1290 Super Duke R (-2019)	Paramani Barkbusters o Flexx	KA-KBBAD
1290 Super Duke R (-2019)		KA-KTMAD
390 Duke (2016-2021)		KA-KTM105
690 Duke, 690 Duke R		KA-KTM100
690 E	Paramani Barkbusters o Flexx	KA-KBBAD
690 Enduro R		KA-KTM100
690 SE	Paramani Barkbusters o Flexx	KA-KBBAD
690 SM	Paramani Barkbusters o Flexx	KA-KBBAD
690 SM, 690 E		KA-KTMAD
690 SMC Supermoto		KA-KTM100
690, 950, 990	Per paramani OEM in plastica (riduce le vibrazioni del manubrio)	KA-VIBRASTOP
790 Adventure (-2019)	Paramani Barkbusters o Flexx	KA-KBBAD
790 Adventure R (-2019)	Paramani Barkbusters o Flexx	KA-KBBAD
790 Adventure, 790 Adventure R		KA-KTMAD
790 Duke (2018-)		KA-KTM100
890R (2020)		KA-KTM100
950 Adventure S	Paramani Barkbusters o Flexx	KA-KBBAD
950 SM		KA-KTM100
950 SMR		KA-KTM100
950 Super Enduro	Paramani Barkbusters o Flexx	KA-KBBAD
950 Super Enduro		KA-KTMAD
950 Supermoto	Paramani Barkbusters o Flexx	KA-KBBAD
950 Supermoto		KA-KTMAD
990 Adventure	Paramani Barkbusters o Flexx	KA-KBBAD

MODELLO	NOTE	CODICE
990 Adventure		KA-KTMAD
990 Adventure Dakar	Paramani Barkbusters o Flexx	KA-KBBAD
990 Adventure Dakar		KA-KTMAD
990 Adventure R	Paramani Barkbusters o Flexx	KA-KBBAD
990 Adventure R		KA-KTM100
990 Adventure R		KA-KTMAD
990 Adventure S	Paramani Barkbusters o Flexx	KA-KBBAD
990 Adventure S		KA-KTMAD
990 SM		KA-KTM100
990 SMR	Paramani Barkbusters o Flexx	KA-KBBAD
990 SMR		KA-KTMAD
990 SMT	Paramani Barkbusters o Flexx	KA-KBBAD
990 SMT		KA-KTM100
990 SMT		KA-KTMAD
990 Super Duke		KA-KTM100
990 Super Duke R		KA-KTM100
990 T Supermoto		KA-KTM100
HUSQVARNA 701 (2021)	Paramani Barkbusters o Flexx	KA-KBBAD
LC4 640 Adventure	Paramani Barkbusters o Flexx	KA-KBBAD
LC4 640 Adventure		KA-KTMAD
LC8 950 Adventure	Paramani Barkbusters o Flexx	KA-KBBAD
LC8 950 Adventure S		KA-KTMAD
Super Duke GT (2017)		KA-KBB315
KYMCO		
AK550 (2018-2021)		KA-KYM105
AK550 Super Tourer (2018-2021)		KA-KYM105
People S200 (-2018)		KA-KYM100C
Visar 125		KA-KYM100B
XCITING 500i (-2018)		KA-KYM100C
XCITING 500R (-2018)		KA-KYM100B
MOTO-GUZZI		
Bellagio 940 (2011)	Non adatto con manopole riscaldate	KA-APR300C
Breva 1100	Senza manopole riscaldate	KA-MOTOBRE
Breva 1200	Senza manopole riscaldate	KA-MOTOBRE
California Models (2007-2012)		KA-GUZ100C-ST
Custom California (2013-2017)		KA-GUZ110
Eldorado (2015-2018)		KA-GUZ110
Griso 1200 SE (2013)	Non adatto con manopole riscaldate	KA-APR300C
Griso 8V (2011-)	Non adatto con manopole riscaldate	KA-APR300C
Norge 1100	Senza manopole riscaldate	KA-MOTOBRE
Norge 1200	Senza manopole riscaldate	KA-MOTOBRE
Norge 1200 (2006-2007)		KA-GUZ105
Norge 1200 GT 8V (-2017)	Con paramani OEM	KA-STELHG
Norge 850	Con paramani OEM	KA-STELHG
Norge GT 8V (2013-2016)	Senza manopole riscaldate	KA-MOTOBRE
Roamer (2016)		KA-GUZ120
Stelvio 1200 GT 8V (-2017)	Con paramani OEM	KA-STELHG
Stelvio 1200 NTX	Con paramani OEM	KA-STELHG
Touring (2013-2017)		KA-GUZ110

MODELLO	NOTE	CODICE
V7 Ballagio 940 (2012-)		KA-V7100C
V7 III Carbon (2020)	Con specchi OEM bar-end	KA-GUZ115
V7 Racer (2012)	Non adatto con manopole riscaldate	KA-APR300C
V7 Racer (2013-)		KA-V7100C
V7 Racer (2016-)	Con specchi OEM bar-end	KA-GUZ115
V7 Special (2013)		KA-V7100C
V7 Stone (2013-)		KA-V7100
V7 Stone II (2013-)		KA-V7100
V7 Stone III (2018)		KA-V7100
V85 TT (2019-2020)	Con paramani OEM	KA-GUZ133
V9 Bobber (2016)		KA-GUZ120
MV AGUSTA		
F4RR (2011-)		KA-MV100
Rivale 800cc (2013-)	Con paramani OEM	KA-MV105
Turismo Veloce (2015-)	Con paramani OEM	KA-MV105
Vespa GT 250, GTS300		KA-VESP100
PIAGGIO		
BV 350		KA-PIA105
GTS 300ie (2009-)		KA-PIA105
MP3 300 LT (2010)		KA-PIA100
MP3 400 (2009)		KA-PIA100
MP3 500IE Sport (2016-2017)		KA-PIA105
MP3 500LT (2016-)		KA-PIA105
ROYAL ENFIELD		
350cc Classic (2000-)		KA-ENF100
350cc Classic (2000-)		KA-ENF105
500cc Classic (2000-)		KA-ENF100
500cc Classic (2000-)		KA-ENF105
Himalayan (2016-)		KA-ENF105
Interceptor 650 (2019)		KA-ENF110
Thunderbird		KA-ENF100C
Thunderbird		KA-ENF105
SUZUKI		
400cc Burgman Limited Edition (2010-)		KA-VS1000UWC
650 Burgman	Diametro interno del manubrio superiore a 16,8 mm	KA-SUZ400-16.8
650 Burgman (-2018)		KA-SUZ400
650 Burgman Deluxe (-2018)		KA-SUZ400
650 Burgman Executive (-2018)	Diametro interno del manubrio superiore a 16,8 mm	KA-SUZ400-16.8C
650 Burgman Executive (-2018)		KA-SUZ400C
B-King		KA-SUZ100
Boulevard	Terminale manubrio a barilotto cromato	KA-SUZBBC
Boulevard C109R (2008)		KA-SUZC109
Boulevard C109R (2008)		KA-C109SNUB
Boulevard C50	Terminale manubrio Torpedo cromato	KA-SUZTC
Boulevard C90	Terminale manubrio Torpedo cromato	KA-SUZTC
Boulevard M109R		KA-SUZM109
Boulevard M109R		KA-SUZM109TC
Boulevard M109R		KA-SUZM109SNUB
Boulevard M50	Terminale manubrio Torpedo cromato	KA-SUZTC

MODELLO	NOTE	CODICE
Boulevard M90		KA-SUZM109
Boulevard M90		KA-SUZM109TC
Boulevard M90		KA-SUZM109SNUB
C800C	Terminale manubrio Torpedo cromato	KA-SUZTC
DL1000 V-Strom	Modelli con manubri diametro interno 14 mm e con paramani OEM	KA-VS1000UWPT
DL1000 V-Strom	Con paramani OEM	KA-VS1000UW-S
DL1000XT ABS (2018)	Con paramani OEM	KA-VS1000UW-S
DL1050 V-Strom (2020)	Con paramani OEM	KA-VS1000UW-S
DL650 V-Strom	Modelli con manubri diametro interno 14 mm e con paramani OEM	KA-VS1000UWPT
DL650 V-Strom	Con paramani OEM	KA-VS1000UW-S
DL650 V-Strom	Modelli con manubri diametro interno 14 mm e senza paramani OEM	KA-VS650WPT
DL650 V-Strom	Senza manopole riscaldate	KA-VS650W-S
DL650XT (2017)	Con paramani OEM	KA-VS1000UW-S
DL650XT ABS (2018)	Con paramani OEM	KA-VS1000UW-S
DR650 SE	Senza manopole riscaldate	KA-VS650W-S
DRZ400	Senza manopole riscaldate	KA-VS650W-S
DRZ400 S	Senza manopole riscaldate	KA-VS650W-S
Gladius 650 (-2014)		KA-SUZ100
GRX-R1000 (2017-2021)		KA-SUZ115
GS500		KA-SUZ100
GSF1250 (2015-)		KA-SUZ100
GSR600A		KA-SUZ100
GSR650		KA-SUZ100
GSR750		KA-SUZ100
GSX1200		KA-SUZ100
GSX1250A		KA-SUZ100
GSX1250FA		KA-SUZ100
GSX1250SA		KA-SUZ100
GSX1300R Hayabusa (-2007)		KA-SUZ200
GSX1300R Hayabusa (2008-)		KA-SUZ200-08
GSX1400R Hayabusa (-2007)		KA-SUZ200
GSX600S, GSX600N		KA-SUZ100
GSX650A		KA-SUZ100
GSX650F		KA-SUZ100
GSX650FA		KA-SUZ100
GSX650S, GSX650N		KA-SUZ100
GSX650SA		KA-SUZ100
GSX-750		KA-SUZ100
GSX-F650 (2008-)		KA-SUZ200
GSX-F650 Katana		KA-SUZ200
GSX-F750 Katana		KA-SUZ200
GSXR1000 (-2016)		KA-SUZ100
GSX-R1000 (-2016)	Manubri con diametro interno 16,8 mm	KA-SUZ100-16.8
GSX-R600 (-2016)	Manubri con diametro interno 16,8 mm	KA-SUZ100-16.8
GSX-R750 (-2016)		KA-SUZ100
GSX-R750 (-2016)	Manubri con diametro interno 16,8 mm	KA-SUZ100-16.8
GSX-S1000FA (2016)		KA-SUZ100
GSX-S750F (2015-)		KA-SUZ100
GSX-S750Z (2017)		KA-SUZ100
Intruder C50	Terminale manubrio a barilotto cromato	KA-SUZBBC

MODELLO	NOTE	CODICE
Intruder C90	Terminale manubrio a barilotto cromato	KA-SUZBBC
Intruder VS800	Terminale manubrio Torpedo cromato	KA-SUZTC
Katana (2019)	Manubri con diametro interno 16,8 mm	KA-SUZ100-16.8
LC1500	Terminale manubrio Torpedo cromato	KA-SUZTC
LS650L (2016-)		KA-SUZM109
M1800R		KA-SUZM109TC
M1800R		KA-SUZM109SNUB
M800	Terminale manubrio Torpedo cromato	KA-SUZTC
Marauder VZ1600	Terminale manubrio Torpedo cromato	KA-SUZTC
SV1000S, SV1000N		KA-SUZ300
SV650		KA-SUZ100
TL1000R		KA-SUZ100
TL1000S		KA-SUZ100
VL800C	Terminale manubrio Torpedo cromato	KA-SUZTC
VL800T	Terminale manubrio a barilotto cromato	KA-SUZBBC
VLR1800T		KA-SUZC109
VLR1800T		KA-C109SNUB
VS800	Terminale manubrio a barilotto cromato	KA-SUZBBC
VS800	Terminale manubrio a barilotto cromato	KA-SUZBBC
VZ800L	Terminale manubrio a barilotto cromato	KA-SUZBBC
TRIUMPH		
955		KA-SPTRIP
Bonneville America (-2017)	Solo modelli con ruote a raggi	KA-BONI
Bonneville Bobber (2016-)	Con specchi OEM bar-end	KA-THRUX105
Bonneville Bobber Black (2018)	Con specchi OEM bar-end	KA-THRUX105
Bonneville Liquid cooled (2016-)	Con specchi OEM bar-end	KA-THRUX105
Bonneville SE 900 (-2014)	Solo con ruote Mag	KA-SCRAM
Bonneville SE 900 (-2014)	Solo con specchi CRG bar-end	KA-SCRAMCRG
Bonneville Speedmaster (-2017)	Solo modelli con ruote a raggi	KA-BONI
Bonneville T100 (2016-2018)	Senza specchi OEM bar-end	KA-BON120
Bonneville T100 (-2017)	Solo modelli con ruote a raggi	KA-BONI
Bonneville T120 (2016-2018)	Senza specchi OEM bar-end	KA-BON120
Roadster (-2019)		KA-TROCIII
Rocket 3 (-2019)		KA-TROCIII
Scrambler 900 (-2017)	Solo con ruote Mag	KA-SCRAM
Scrambler 900 (-2017)	Solo con specchi CRG bar-end	KA-SCRAMCRG
Speed Triple (-2010)		KA-SPTRIP
Speed Triple 1050 (2011-)		KA-SPTRIP11
Speed Triple 1050 (2011-)	Solo con specchi CRG bar-end	KA-SPTRIP11CRG
Speed Triple 1050S (2016-2020)	Con specchietti Triumph	KA-THRUX100REV2
Speed Twin (2019-2020)	Con specchietti Triumph	KA-THRUX100REV2
Sprint GT 1050 (-2017)		KA-TST1050REV1
Sprint RS 955		KA-TST1050REV1
Sprint ST 1050		KA-TST1050REV1
Sprint ST 955		KA-TST1050REV1
Street Cup (2017-2020)	Con specchietti Triumph	KA-THRUX100REV2
Street Scrambler (2017-)	Con manopole riscaldate OEM	KA-STRTWIN
Street Triple 675 (-2010)		KA-THRUX
Street Triple 675/R (2011-2017)	Senza paramani	KA-TIG100
Street Triple 675R (-2010)		KA-THRUX

MODELLO	NOTE	CODICE
Street Triple 765 R (2019)	Con specchietti Triumph	KA-THRUX100REV2
Street Triple R (2018)	Con specchietti Triumph	KA-THRUX100REV2
Street Twin 900cc (2016-2018)	Con manopole riscaldate OEM	KA-STRTWIN
Thruxton 1200 (-2018)	Con specchi OEM bar-end	KA-THRUX105
Thruxton 1200R (2016-2020)	Con specchietti Triumph	KA-THRUX100REV2
Thruxton 900		KA-THRUX
Thunderbird (1995-2004)	Con terminali manubrio OEM in acciaio inox	KA-TB900
Thunderbird 1600 (-2010)		KA-TBIRD
Thunderbird 1600 (2011-)		KA-TBIRDSS
Thunderbird 1700LT (2013-)		KA-TBIRDSS
Thunderbird Commander 1700 (2013-)		KA-TBIRDSS
Thunderbird Storm (-2010)		KA-TBIRDB
Thunderbird Storm (2012-)		KA-TBIRDSSB
Tiger 1050	Con o senza paramani OEM	KA-TIG1050
Tiger 1200 Explorer (2013-2017)	Con paramani OEM	KA-TIG1200
Tiger 1200 Explorer XCX (2016-2017)	Senza paramani	KA-TIG100
Tiger 1200 Explorer XCX (2016-2017)	Con paramani OEM	KA-TIGXC
Tiger 800 (1997)		KA-TIG800
Tiger 800 (2011-2017)	Senza paramani	KA-TIG100
Tiger 800 (2011-2017)	Con paramani OEM	KA-TIGXC
Tiger 800XC (2011-2017)	Senza paramani	KA-TIG100
Tiger 800XC (2011-2017)	Con paramani OEM	KA-TIGXC
Tiger 800XR (-2017)	Senza paramani	KA-TIG100
Tiger 955i (2001-)		KA-TIG995
Tiger Sport (2013-)		KA-TIG121
Tiger Sport 850 (2021-)	Con o senza paramani OEM	KA-TIG122
Trophy 1200 (2013-)		KA-TST1050REV1
URAL		
Ural (2000-2014)		KA-URAL100
VICTORY		
(2007) Models	Terminale manubrio a barilotto cromato	KA-HDBBCV07
(2007) Models	Terminale manubrio Torpedo cromato	KA-HDTCV07-0.8
(2008-) Models	Terminale manubrio a barilotto cromato	KA-HDBBCV08-0.8
(2008-) Models	Terminale manubrio Torpedo cromato	KA-HDTCV08-0.8
Cruiser models (2007)		KA-SUZBBCV07
Gunner (2013-)		KA-VICSNUBGUN
High-Ball (2013-)		KA-VICSNUB
Judge (2013-)		KA-VICSNUB
YAMAHA		
FJ-09 (2014-2017)	Non adatto con manopole riscaldate, solo con paramani OEM	KA-YAM650
FJ-09 (2014-2017)	Con manopole riscaldate	KA-YAM650HG
FJR1300 (-2018)		KA-YAM500
FJR1300 AS (-2018)		KA-YAM500
FZ-1 (-2017)		KA-YAM300S
FZ-1 S (-2017)		KA-YAM300S
FZ6		KA-YAM300S
Majesty (2013-2014)	Senza paramani OEM	KA-YAM810
Majesty (2013-2014)	Solo con specchi CRG bar-end	KA-YAM810CRG
Midnight Star		KA-YAMSTAR

MODELLO	NOTE	CODICE
MT-01		KA-YAM300
MT-03 (-2016)		KA-YAM800
MT-07 / FZ-07 (-2017)	Senza paramani OEM	KA-YAM810
MT-07 / FZ-07 (-2017)	Solo con specchi CRG bar-end	KA-YAM810CRG
MT-07 ABS (-2017)	Con manopole riscaldate OEM o Oxford	KA-KBB225
MT-07 Tracer (2018-)	Con o senza paramani OEM, non adatto con manopole riscaldate	KA-YAM653
MT-09 / FZ-09 (-2018)	Senza paramani OEM	KA-YAM810
MT-09 / FZ-09 (-2018)	Solo con specchi CRG bar-end	KA-YAM810CRG
MT-09 ABS (-2017)	Con manopole riscaldate OEM o Oxford	KA-KBB225
MT-09 SP (2018)	Senza paramani OEM	KA-YAM810
MT-09 SP (2018)	Solo con specchi CRG bar-end	KA-YAM810CRG
MT-09 Sport Tracker	Senza paramani OEM	KA-YAM810
MT-09 Sport Tracker	Solo con specchi CRG bar-end	KA-YAM810CRG
MT-09 Sport Tracker ABS	Senza paramani OEM	KA-YAM810
MT-09 Sport Tracker ABS	Solo con specchi CRG bar-end	KA-YAM810CRG
MT-09 Street Rally (-2017)	Senza paramani OEM	KA-YAM810
MT-09 Street Rally (-2017)	Solo con specchi CRG bar-end	KA-YAM810CRG
MT-10 (2016-)	Senza paramani OEM	KA-YAM810
MT-10 (2016-)	Solo con specchi CRG bar-end	KA-YAM810CRG
MT-10 (2017-)	Solo con manopole riscaldate	KA-YAM650HG
Niken (2018-)	Senza paramani OEM	KA-YAM810
Niken (2018-)	Solo con specchi CRG bar-end	KA-YAM810CRG
R1 (2004-)		KA-YAM500
R6		KA-YAM500
R6 (2003-)	Con manubrio filettato	KA-YAM200
Raider		KA-YAMLINER
Roadliner		KA-YAMLINER
Roadstar 1100 (2004-)		KA-YAMSTAR
Roadstar 1300 (2004-)		KA-YAMSTAR
Roadstar 1600 (2004-)		KA-YAMSTAR
Roadstar 1700 (2004-)		KA-YAMSTAR
Stratoliner		KA-YAMLINER
Stryker 80 Star (2013-)		KA-YAMSTAR
Super Tenere 1200 (2018-2021)	Con paramani OEM	KA-YAM625
Super Tenere 1200 (2018-2021)	Con paramani Acerbis X-Factor	KA-YAM626
Super Tenere XT1200Z (2010-2013)	Con o senza paramani OEM, adatto con Barkbusters BHG40	KA-YAM630
TDM 850		KA-YAM300S
TDM 900		KA-YAM300S
Tenere 700 (2019-2021)	Con paramani OEM	KA-YAM625
Tenere 700 (2019-2021)	Con paramani Acerbis X-Factor	KA-YAM626
Tenere XT 600Z (2008-2009)	Senza manopole riscaldate	KA-YAM600
Tenere XT 660Z (2008-)	Con paramani OEM o paramani Barkbusters	KA-YAM620
Tenere XT 660Z (2008-2009)	Senza manopole riscaldate	KA-YAM600
Tenere XT660Z (2008-)	Con paramani Barkbusters	KA-KBB110
T-Max 500 Scooter (2010-)		KA-YAMTMAX
T-Max 530 (2012-)		KA-YAMTMAX
T-Max 560 (2020)	Senza paramani OEM	KA-YAM810
Tracer 700 (2020-2021)	Senza paramani OEM, non adatto con manopole riscaldate	KA-YAM654
Tracer 900 (2018-2020)	Con paramani OEM e manopole riscaldate	KA-YAM651HG
Tracer 900 (2018-2020)	Con paramani OEM e manopole non riscaldate	KA-YAM652

MODELLO	NOTE	CODICE
Tracer 900GT (2018-2020)	Con paramani OEM e manopole riscaldate	KA-YAM651HG
Tracer MT-09 (2014-2017)	Non adatto con manopole riscaldate, solo con paramani OEM	KA-YAM650
Tracer MT-09 (2014-2017)	Solo con manopole riscaldate	KA-YAM650HG
V-Max (2009-2017)		KA-YAM700
V-Star 1100 (2004-)		KA-YAMSTAR
V-Star 1300 (2004-)		KA-YAMSTAR
V-Star 1600 (2004-)		KA-YAMSTAR
V-Star 1700 (2004-)		KA-YAMSTAR
V-Star XVS650 Classic (1997-)		KA-YAMWARSNUB
Warrior Cruiser (2008-)		KA-YAMWARSNUB
XJ1300		KA-YAM300S
XJR1200		KA-YAM300S
XJR1300		KA-YAM300S
XMAX 125 (2018)		KA-YAMXMAX
XMAX 125 (2018)	Solo con R&G bar-end sliders	KA-YAMXMAXR&G
XMAX 300 Scooter (2017-)		KA-YAMXMAX
XMAX 300 Scooter (2017-)	Solo con R&G bar-end sliders	KA-YAMXMAXR&G
XMAX 400 (2018)		KA-YAMXMAX
XMAX 400 (2018)	Solo con R&G bar-end sliders	KA-YAMXMAXR&G
XSR700 (2016-2021)	Senza paramani OEM	KA-YAM810
XSR700 (2016-2021)	Solo con specchi CRG bar-end	KA-YAM810CRG
XSR900 (2016-2021)	Senza paramani OEM	KA-YAM810
XSR900 (2016-2021)	Solo con specchi CRG bar-end	KA-YAM810CRG
XT 250 (2008-)		KA-YAM655
XT660R (-2017)		KA-YAM610
XT660X		KA-YAM610
XV1900 Midnight Star		KA-YAMLINER
XV1900AT (2013-)		KA-YAMLINER
XVS1300A		KA-YAMSTAR
XVS950A		KA-YAMSTAR
UNIVERSALE		
Manubri aftermarket LSL, Pro-Taper, Magura & Spiegler o altri manubri con diam. interno 14 mm	Chiedere info via email con il modello di moto e anno	KA-LSL13.75
Manubri e specchietti RIZOMA	Articolo speciale, prego inviare mail con richiesta dettagli completi prima di ordinare	KA-RIZ28.5



NONOISE



**nonoise**TM
HEARING PROTECTORS **MOTORSPORT**



LA PROTEZIONE UDITO INTELLIGENTE

Pensando **appositamente ai motociclisti** NoNoise ha creato le prime ed uniche protezioni udito intelligenti. Infatti già dopo soli 15 minuti a 95 km/h l'udito subisce danni permanenti, ma con NoNoise il maggior numero possibile di onde sonore dannose vengono filtrate prima che queste raggiungano il timpano. Tuttavia NoNoise **non blocca il condotto uditivo** e quindi non provoca il fastidioso effetto di "occlusione". Voci, sirene e clacson rimangono perfettamente udibili, grazie allo speciale filtro ceramico brevettato in grado di filtrare le frequenze in maniera selettiva, garantendo sempre una piena consapevolezza di ciò che accade.

I dispositivi NoNoise Moto sono progettati appositamente per attenuare **solo le frequenze dannose**, proteggendo i motociclisti dal vento e dai rumori della strada senza tuttavia interferire con la percezione dell'ambiente circostante. L'attenuazione sonora media misurata (EN352-2:2002) è di 29,6 dB alle frequenze massime (più dannose).

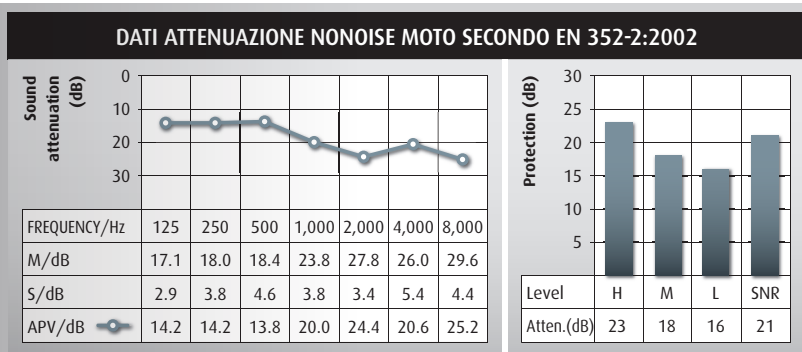

LEGENDA: tutti i dati sono in decibel (dB)
 M = attenuazione media
 S = deviazione standard
 APV = valore di protezione ipotizzato (Assumed Protection Value)
 SNR = indice di valutazione (Single Number Rating)
 H , M , L = Valore in spettro frequenza alta, media e bassa





- Riducono il rumore del vento e della strada
- Consentono la comunicazione e l'utilizzo dell'interfono
- Non interferiscono con la percezione dell'ambiente circostante
- Sono comodi, lavabili e riutilizzabili
- Sono frutto di anni di sviluppo da parte di esperti professionisti

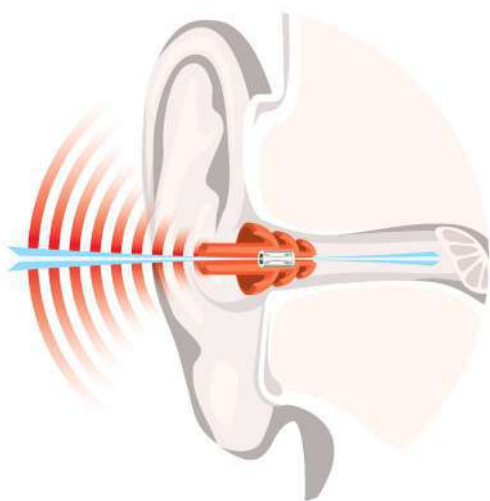

PERCHÉ NONOISE È COSÌ DIVERSO DAGLI ALTRI DISPOSITIVI DI PROTEZIONE?

Canale interno del filtro brevettato di tipo Venturi e progettato specificamente per ciascun singolo modello.

Filtro di precisione in **ceramica brevettato** posizionato, per la massima protezione, più in profondità, nel condotto uditivo, rispetto ad altri prodotti.

Termoplastico, ipo-allergenico, **senza silicone**, per il **massimo comfort**

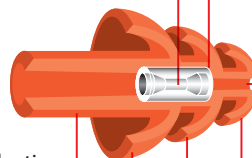

Permette l'ascolto di una **conversazione normale** abbassando efficacemente il volume di altri rumori senza alcuna distorsione.

Design unico in **tre differenti sezioni** per il massimo del comfort **adatto a tutte le età** (diametro da 6 a 13,5 mm)

R&G RACING





PROTEZIONI PER I MOTOCICLISTI PIÙ ESIGENTI

Già da alcuni anni Forbikes è distributore esclusivo per l'Italia dei rinomati articoli R&G Racing, altamente apprezzati dai motociclisti italiani che sono sempre più scrupolosi nel proteggere le proprie moto.

R&G Racing è un'azienda inglese che vanta un team di professionisti sempre pronti a realizzare le protezioni per gli **ultimi modelli** di moto uscenti sul mercato.

Specializzata nella produzione di **protezioni** per la salvaguardia di ogni parte della moto, la gamma degli articoli spazia dalle protezioni motore, alle retine radiatore, portatarga e molto altro. Senza dimenticare i **tamponi/protezioni telaio** la cui produzione è iniziata nel 1999 e velocemente è diventato il prodotto di punta del brand inglese grazie al polietilene ad alta intensità (HDPE), progettato per usarsi senza andare in frantumi in caso di caduta.

Tutti i prodotti R&G Racing sono progettati **su misura** per i principali modelli con materie prime di qualità e lavorazioni innovative, in modo da assicurare un'ottima protezione della moto. Di seguito i pre-codici degli articoli più rinomati di R&G.



PARAMOTORE ADVENTURE BARS

AB-

Racchiudono il motore offrendo un livello alternativo di protezione. Rispecchiano le linee della moto per cui sono progettati e sono ultrasensibili.



STABILIZZATORI / TAMPONI MANUBRIO

BE-

Contribuiscono a proteggere le costose leve e i semimanubri da danni derivanti da cadute o scivolamenti, infatti sono progettati per non staccarsi in caso di impatto.



PROTEZIONE LEVA FRENO

BLG-

Grazie al loro design stampato a iniezione sono super resistenti e, allo stesso tempo, leggere, consentendo la protezione ottimale sia in strada che in pista.



PLACCHETTE POST RIMOZIONE POGGIPIEDE

BLP-

Sono progettate per coprire i fori del poggiatesta ed evitare l'ingresso di sporco e polvere, proteggendo le filettature dalla corrosione.



RETINA PROTEZIONE RADIATORE CON LOGO

BRG-

Ogni kit contiene un design unico e distintivo per una specifica serie di moto. La loro costruzione in acciaio inossidabile gli consente di essere incredibilmente dure e resistenti.



PARACATENA

CG-

I paracatena R&G sono facili da installare e offrono una copertura e una protezione completa della catena, prevenendo l'usura della moto.



PROTEZIONE LEVA IN CARBONIO FACTORY

CLG-

Eleganti, facili da installare e incredibilmente resistenti. Evitano l'innesto accidentale del freno o della frizione durante la guida in pista o su strada.



TAMPONI / PROTEZIONI TELAIO

CP-

Mantengono il telaio, il motore e gli altri componenti critici lontani da terra in caso di incidente o scivolata. Disponibili nella forma "Classica" (rotonda) o "Aero" (a goccia).



NOTTOLINI CAVALLETTO POSTERIORE

CR-

Nottolini dal duplice scopo: proteggono il forcellone e i componenti limitrofi e, allo stesso tempo, consentono il sollevamento della moto tramite un cavalletto posteriore.



RETINA PROTEZIONE COLLETTORI SCARICO

DG-

Migliora immediatamente l'aspetto della moto grazie alla rifinitura in nero, titanio o di colori personalizzati. Viene poi verniciata a polvere per una finitura resistente e duratura.



KIT SCHERMO PROTEZIONE STRUMENTAZIONE

DSP-

Pensato su misura per i vari modelli di moto, è stato pensato per proteggere il delicato schermo da graffi e segni indesiderati, grazie allo speciale materiale antigraffio.



PROTEZIONI MOTORE (PEZZO SINGOLO)

ECC-

Utilizzate sia nei paddocks di tutto il mondo, sia sulle moto da strada. Sono realizzate con polipropilene resistente e vengono montate direttamente sugli involucri già presenti.



SLIDERS PROTEZIONI MOTORE

ECS-

Offrono una protezione resistente per gli involucri spesso delicati ed esposti. Si avviano direttamente sulla parte superiore degli involucri originali, sporgendo leggermente.



STAFFA SUPPORTO SCARICO

EH-

Sono state progettate appositamente per supportare adeguatamente lo scarico e conferire alla moto un aspetto più sportivo ed elegante.



PROTEZIONE SILENZIATORE

EP-

Costituite da una clip in acciaio inossidabile che circonda lo scarico e una striscia di gomma morbida che impedisce graffi garantendo che la protezione non scivoli o si muova.



ADESIVI ANTI-SCIVOLO PARATACCO

EZBG-

Specificamente progettati per essere resistenti e fornire al motociclista una protezione tra lo stivale e il forcellone o il telaio, evitando l'usura e i danni indesiderati.



ADESIVI ANTI-SCIVOLO SERBATOIO

EZRG-

Permettono di mantenere una postura stabile in curva e in frenata e di alleviare l'affaticamento. Ogni kit di adesivi antiscivolo comprende pezzi precedentemente tagliati per i vari modelli.



ADATTATORI PER MINIFRECCE ANTERIORI

FAP-

Consentono l'uso delle minifrecce R&G come indicatori frontali, eliminando i grandi indicatori OEM e contribuendo a dare alla moto un aspetto più sportivo.



ESTENSIONE PARAFANGO ANTERIORE

FERG-

Offrono una protezione aggiuntiva da detriti, sabbia, fango e acqua sollevata dalla ruota anteriore. Ogni design assicura una protezione su misura per il parafango previsto.



INSERTO PROTEZIONE TELAIO

FI-

Realizzati su misura per i principali modelli di moto, proteggono i fori del telaio da sporco, accumuli di fango e detriti che possono causare corrosione e ruggine.



PROTEZIONI PERNO FORCELLA ANTERIORE

FP-

La forcella è una delle prime parti a toccare a terra in caso di caduta. Queste protezioni sono semplicissime da montare e ti faranno risparmiare i soldi di una nuova forcella.



TAPPETO

GM0001BK Garage, singolo

GM0002BK Officina, doppio

I tappeti R&G sono progettati per essere resistenti agli agenti chimici e alle abrasioni. Il retro è in gomma antiscivolo ed assicura che rimangano esattamente dove sono posizionati.



PROTEZIONE FANALE ANTERIORE

HLS-

Realizzati in acrilico trasparente e progettati per adattarsi a una gamma di modelli in continua crescita. Facili da montare, possono essere facilmente rimossi per la pulizia.



NOTTOLINI CAVALLETTO

ITBO-

Questi nottolini cavalletto in alluminio anodizzato sono adatti per la maggior parte dei modelli. Vengono forniti in coppia e disponibili in 3 opzioni di colore: nero, titanio e argento.



KIT PROTEZIONI MOTORE

KEC-

Questi kit sono utili per risparmiare sulle Case Cover (ECC-), rispetto ad acquistare gli articoli individualmente. Progettati per proteggere il motore in caso di incidente.



PROTEZIONE LEVA FRENO IN CARBONIO

LG-

Sono realizzate in fibra di carbonio rinforzata con Kevlar e sono eccezionalmente robuste e leggere. Impediscono che la leva del freno si innesti accidentalmente.



PORTATARGA

LP-

Trasformano radicalmente la parte posteriore di qualsiasi moto, conferendo un aspetto molto elegante, raffinato e sportivo e sostituendo i portatarga OE, spesso grandi e ingombranti.



PLACCHETTE COPRIFORI SPECCHIETTI

MBP-

Queste placchette si montano nel punto di fissaggio degli specchietti e si adattano alla rientranza che si crea, aiutando a trasformare la moto da strada in moto da pista.



PROTEZIONE LEVA FRENO / FRIZIONE

MLG-

Sono state sviluppate per evitare l'attivazione accidentale della leva freno/frizione durante le corse ravvicinate in pista ma possono essere ugualmente applicate alla guida su strada.



RISERS SPECCHIETTI

MR-

I risers specchietti sono perfetti per aumentare la visibilità posteriore durante la guida. Occorre semplicemente svitare gli specchietti e avvitare l'adattatore in posizione.



RETINA PROTEZIONE RADIATORE OLIO

OCG-

Sono progettate per non limitare il flusso di aria al radiatore e prevenire che i detriti sollevati da altri motociclisti (o dalle proprie ruote) possano danneggiare la moto.



BASE APPOGGIO CAVALLETTO

PKS-

Si fissano nella parte inferiore del cavalletto per allargare la superficie di appoggio ed evitare che il carico su di essa provochi uno sprofondamento nel terreno.



RETINA PROTEZIONE RADIATORE

RAD-

Sono realizzate con una robusta rete di alluminio e proposte in una vasta gamma di stili per adattarsi alle moto di tutte le marche. Disponibili anche in titanio.



LUCE POSTERIORE PIOGGIA USO SU PISTA

RAINLIGHT1

Luminosa, compatta e semplice da usare. Comprende ogni accessorio per l'installazione, un leggerissimo involucro di plastica, ed un interruttore on/off clip-on.



PARAFANGO POSTERIORE

RGH-

Progettati per seguire il profilo della moto e la forma della gomma posteriore, aiutano a proteggere il sottoscocca e l'ammortizzatore posteriore da danni, sporco e detriti.



PEDANE ARRETRATE

RSET-

Realizzate in alluminio leggero per garantire un'elevata resistenza e durata. Sono ampiamente regolabili per adattarsi ad ogni pilota.



RETINA PROTEZIONE RADIATORE OLIO ACCIAIO INOSSIDABILE

SCG-

Perfette per motociclisti che possono affrontare terreni e condizioni impegnative, sono progettate per il massimo flusso d'aria al radiatore dell'olio.



PROTEZIONE MONOAMMORTIZZATORE

SHOCK-

Un tubo ad alto impatto, impermeabile e ventilato, fatto al 100% in CR Neoprene™ di massima qualità che è bifoderato con nylon elasticizzato su entrambi i lati.



PROTEZIONI FORCELLONE

SP-

Richiedono solo pochi minuti per essere installate e per proteggere i componenti del forcellone in caso di incidente o caduta, mantenendoli sollevati dal terreno.



RETINA PROTEZIONE RADIATORE ACCIAIO INOSSIDABILE

SRG-

Rappresentano una versione più robusta delle retine in alluminio e sono pensate soprattutto per moto Adventure e Touring. Incredibilmente resistenti e impermeabili alla ruggine.



CURSORI PERNO RUOTA POSTERIORE

SS-

Non solo aiutano il forcellone e la pinza del freno posteriore in caso di caduta, ma possono anche essere utilizzati per sollevare una moto utilizzando un cavalletto di tipo convenzionale.



PINNA SICUREZZA CATENA

TG-

Realizzate in polietilene leggero e ad alta densità oppure in alluminio, possono essere facilmente adattate alla posizione della ruota posteriore.



PIASTRA PER AGGANCIAMENTO CINGHIE

TH-

Consentono di trasportare la moto in pista o dal meccanico del posto, in modo sicuro, facile e comodo. Cinghie non incluse.



SLIDERS IN CARBONIO

TLS- Codone posteriore

TS- Serbatoio

Progettati appositamente per adattarsi in modo perfetto al serbatoio, agli angoli e all'area più pronunciate che potrebbero danneggiarsi in caso di incidente o caduta.



PEDANE RACING

TP-

Realizzate con gli stessi materiali di alta qualità dei tamponi/protezioni telaio, si montano direttamente sulle pedane OEM e sono progettate per ridurre i danni in caso di caduta.





Via Agnoletti 4 F/G, 42124 Reggio Emilia - Tel: 0522 232590 - Fax: 0522 238020
Email: commerciale@forbikes.it - www.forbikes.it