



Malaguti
IDEE IN MOTO

F 10 WAP RESTYLING KAT EURO 2 ('01/'02 - ZJM 48)



TELAIO - INDICE TAVOLE

FRAME - INDEX OF THE TABLES

TAV. A	TAV. C-D	TAV. E	TAV. F	TAV. G
TAV. H	TAV. I	TAV. L	TAV. M	TAV. N
TAV. OO	TAV. O			

MOTORE - INDICE TAVOLE

ENGINE - INDEX OF THE TABLES

TAV. R	TAV. R1			
--------	---------	--	--	--

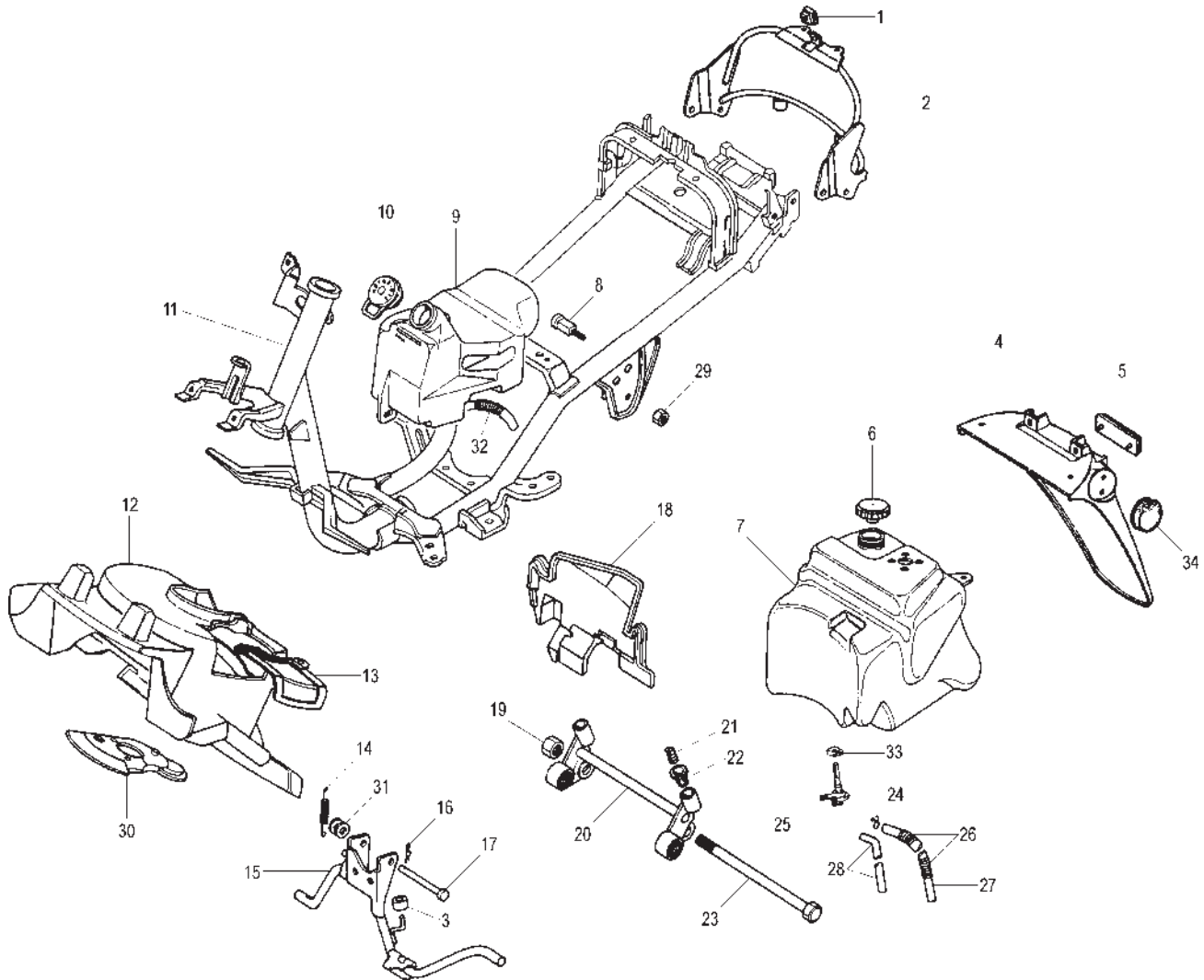
Telaio e serbatoio - Tank & frame

Nr.	Codice	Q.tà	Descrizione
1	184.007.00	1	Clips vite autofilettante
2	156.059.99	1	Telaio supporto porta pacco
3	072.064.00	1	Gommino cavalletto
4	057.034.07	1	Codino parafrangente posteriore
5	071.117.01	1	Catadiottro rosso
6	092.016.03	1	Tappo serbatoio benzina
7	161.063.00	1	Serbatoio benzina
8	190.020.13	2	Perno supporto motore
9	069.011.00	1	Serbatoio olio
10	071.144.00	1	Tappo serbatoio olio
11	156.061.99	1	Telaio
12	055.040.03	1	Parafrangente anteriore
13	071.150.03	1	Coperchio parafrangente anteriore
14	147.109.13	1	Molla doppia cavalletto
15	158.034.99	1	Cavalletto completo
16	184.011.00	1	Copiglia
17	150.177.15	1	Perno cavalletto
18	057.031.00	1	Bancalina motore
19	185.011.00	1	Dado fulcro motore
20	174.018.99	1	Attacco motore completo
21	147.106.14	2	Molla antivibrazione
22	080.010.00	2	Portamolla in gomma
23	190.019.13	1	Perno motore
24	093.045.00	1	Rubinetto benzina
25	167.018.13	2	Fascetta benzina

No.	Code	Q.ty	Description
1	184.007.00	1	Fairing fixing clip
2	156.059.99	1	Rear rack fixing bracket
3	072.064.00	1	Main stand bump stop
4	057.034.07	1	Rear splash guard
5	071.117.01	1	Reflector
6	092.016.03	1	Fuel tank cap
7	161.063.00	1	Fuel tank
8	190.020.13	2	Engine mounting bolt
9	069.011.00	1	Oil tank
10	071.144.00	1	Oil tank cap
11	156.061.99	1	Frame
12	055.040.03	1	Front mudguard
13	071.150.03	1	Front mudguard cover
14	147.109.13	1	Main stand spring
15	158.034.99	1	Main stand assy
16	184.011.00	1	Split pin
17	150.177.15	1	Main stand pivot pin
18	057.031.00	1	Engine panel
19	185.011.00	1	Lower engine mount nut
20	174.018.99	1	Engine mount bracket
21	147.106.14	2	Full bump spring
22	080.010.00	2	Full bump spring cup
23	190.019.13	1	Lower engine mount bolt
24	093.045.00	1	Fuel cock
25	167.018.13	2	Petrol pipe clamp

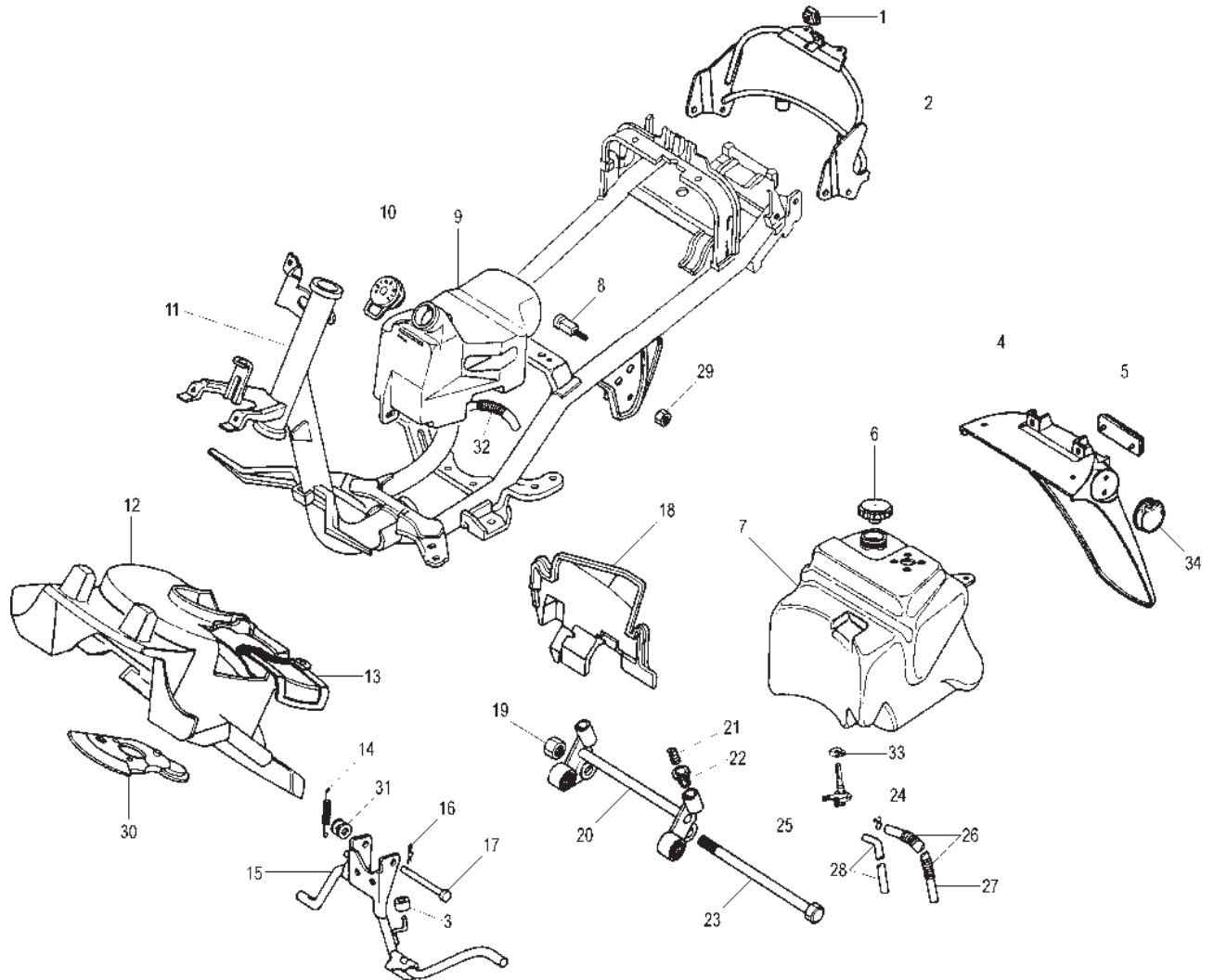

Nr.	Codice	Q.tà	Descrizione
26	147.080.13	1	Molla protezione tubo benzina
27	180.010.50	1	Tubo benzina
28	180.003.54	1	Tubo benzina
29	185.012.00	2	Dado fulcro bilanciare
30	057.032.03	1	Bancalina forcella
31	071.140.03	1	Rondella in gomma
32	147.084.13	1	Molla protezione tubo olio
33	167.031.00	1	Fascetta rubinetto benzina
34	071.225.00	2	Catadiottro ambra

No.	Code	Q.ty	Description
26	147.080.13	1	Pipe spring
27	180.010.50	1	Fuel hose
28	180.003.54	1	Fuel hose
29	185.012.00	2	Nut
30	057.032.03	1	Bottom yoke protector
31	071.140.03	1	Main stand washer
32	147.084.13	1	Oil pipe spring
33	167.031.00	1	Petrol pipe clamp
34	071.225.00	2	Amber reflector

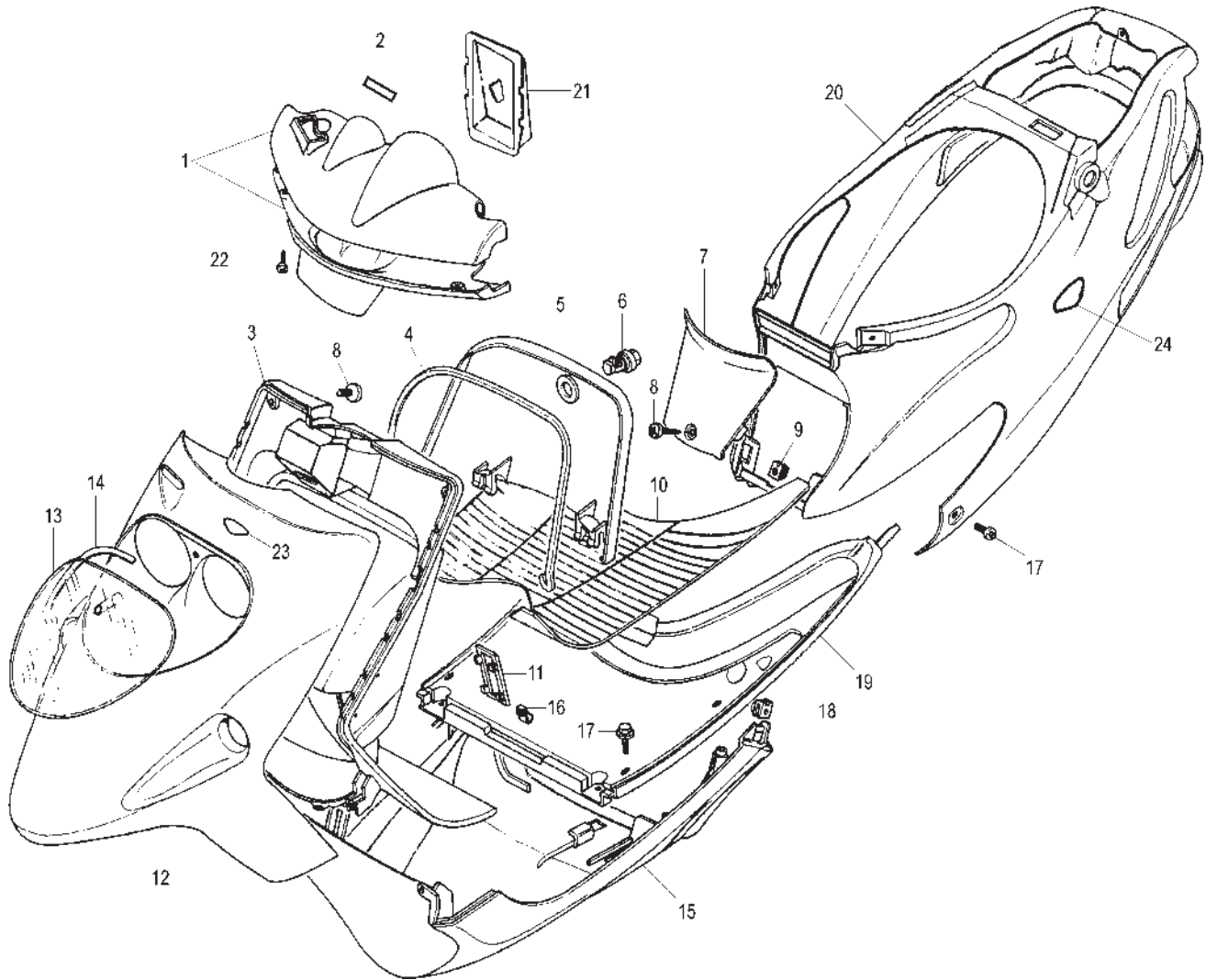

Nr.	Codice	Q.tà	Descrizione
1	071.284.- -	1	Coprimanubrio (super. + infer.) *
2	181.126.00	1	Marca cruscotto
3	065.035.03	1	Paragambe
4	072.051.03	1	Guarnizione bauletto
5	071.141.03	1	Coperchio bauletto
6	090.024.00	1	Serratura bauletto
7	071.147.- -	1	Coperchio carena *
8	184.041.15	14	Vite scudo paragambe
9	184.007.00	6	Clips vite autofilettante
10	064.008.07	1	Pedana in gomma
11	071.145.00	1	Coperchio numeri
12	066.042.- -	1	Scudo anteriore *
13	063.131.00	1	Kit protezione trasparente faro
14	071.153.00	1	Biadesivo protezione faro
15	063.078.- -	1	Puntone *
16	188.043.15	2	Cerniera
17	184.155.15	6	Vite pedana - carena
18	184.008.00	2	Dado a molla
19	064.009.03	1	Pedana in plastica
20	063.079.- -	1	Carena posteriore *
21	071.151.07	1	Coperchio portabatteria
22	184.071.15	3	Vite coprimanubrio
23	181.338.00	1	Marca scudo

No.	Code	Q.ty	Description
1	071.284.- -	1	Handlebar cover * (upper + lower)
2	181.126.00	1	Dashboard label
3	065.035.03	1	Front inner shield
4	072.051.03	1	Glove box seal
5	071.141.03	1	Glove box cover
6	090.024.00	1	Glove box lock
7	071.147.- -	1	Inspection cover *
8	184.041.15	14	Screw
9	184.007.00	6	Fairing fixing clips
10	064.008.07	1	Mat
11	071.145.00	1	VIN numbers inspection cover
12	066.042.- -	1	Front shield *
13	063.131.00	1	Head light protection glass
14	071.153.00	1	Head light cover seal
15	063.078.- -	1	Belly pan*
16	188.043.15	2	Clip
17	184.155.15	6	Footboard bolt
18	184.008.00	2	Nut
19	064.009.03	1	Foot board panel
20	063.079.- -	1	Rear fairing *
21	071.151.07	1	Battery cover
22	184.071.15	3	Handlebar cover screw
23	181.338.00	1	Front shield blue label

* Vedi tav. N° OO Colori

* Refer to N° OO - Colour table

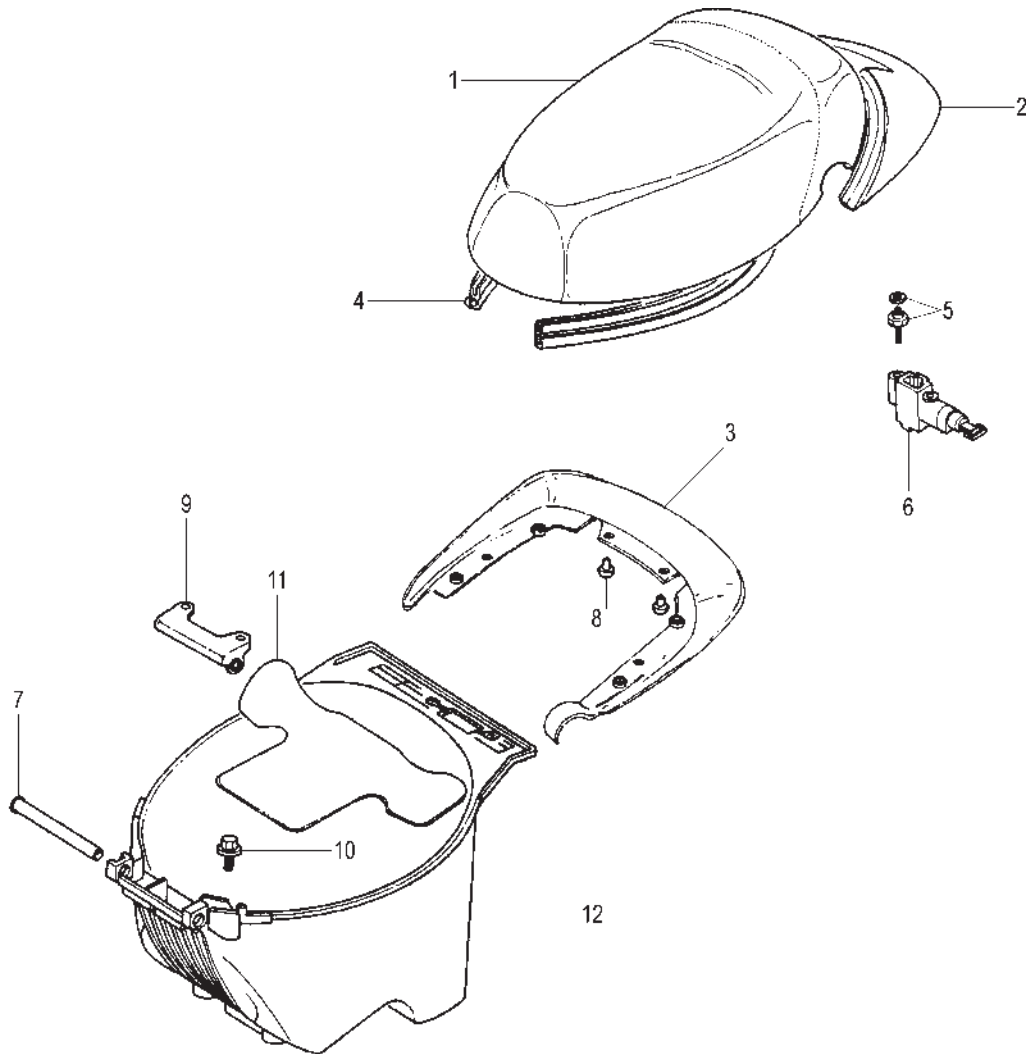

Nr.	Codice	Q.tà	Descrizione
1	106.062.03	1	Sellone
2	063.083.- -	1	Codino sottosella *
3	063.080.- -	1	Spoiler *
4	072.048.03	1	Guarnizione sottosella
5	190.023.00	2	Vite fissaggio serratura
6	090.023.00	1	Serratura sella
7	150.174.13	1	Tubo fulcro sella
8	071.152.03	2	Paracolpi
9	188.040.99	1	Supporto sella
10	190.022.00	2	Vite fissaggio vano porta casco
11	072.063.03	1	Protezione vano porta casco
12	065.034.07	1	Vano portacasco

No.	Code	Q.ty	Description
1	106.062.03	1	Seat
2	063.083.- -	1	Seat tail *
3	063.080.- -	1	Seat back spoiler *
4	072.048.03	1	Seat base seal
5	190.023.00	2	Seat lock fixing screw
6	090.023.00	1	Seat lock
7	150.174.13	1	Seat hinge pin
8	071.152.03	2	Grommet
9	188.040.99	1	Seat hinge bracket
10	190.022.00	2	Fixing bolt
11	072.063.03	1	Helmet case protection
12	065.034.07	1	Helmet case

* Vedi tav. N° OO Colori

* Refer to N° OO - Colour table

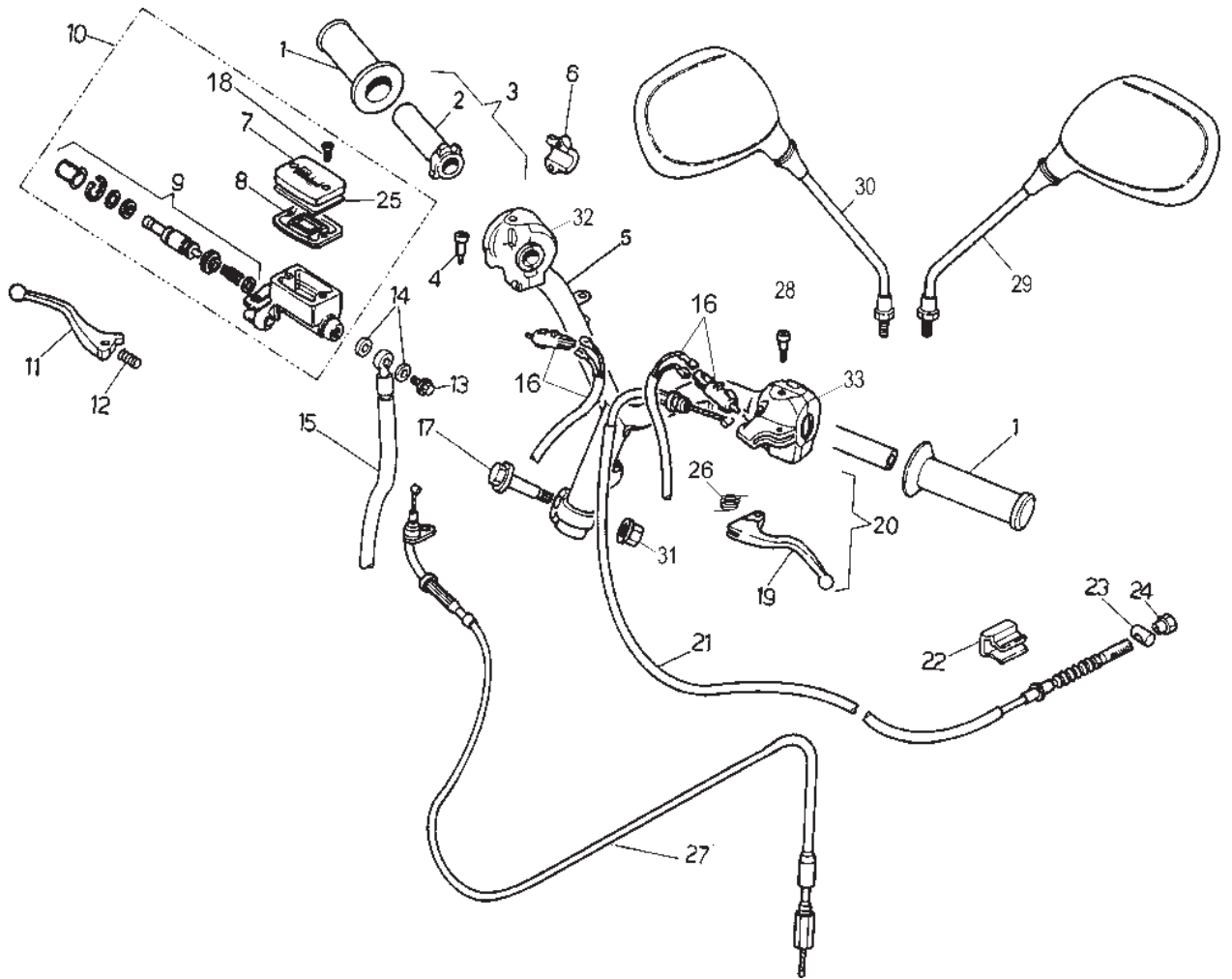

Nr.	Codice	Q.tà	Descrizione	No.	Code	Q.ty	Description
1	097.014.03	1	Kit manopole (dx + sx)	1	097.014.03	1	Handgrip set (r/h+l/h)
2	121.134.00	1	Tubo comando gas	2	121.134.00	1	Throttle twist grip tube
3	028.018.00	1	Comando gas completo	3	028.018.00	1	Twist grip tube & bracket
4	121.106.00	1	Fulcro leva dx	4	121.106.00	1	R/h lever bolt
5	162.027.13	1	Manubrio	5	162.027.13	1	Handlebar
6	121.139.00	1	Attacco pompa	6	121.139.00	1	Front brake clamp
7	121.127.00	1	Coperchio pompa	7	121.127.00	1	Cover
8	121.099.00	1	Guarnizione pompa	8	121.099.00	1	Master cylinder seal
9	121.128.00	1	Pistone completo	9	121.128.00	1	Piston kit
10	030.016.03	1	Pompa freno completa	10	030.016.03	1	Master cylinder assy
11	121.132.03	1	Leva dx	11	121.132.03	1	R/h brake lever
12	121.108.00	1	Molla leva dx	12	121.108.00	1	R/h brake lever spring
13	150.024.14	1	Vite trasmissione idraulica	13	150.024.14	1	Banjo bolt
14	190.006.00	2	Rasamento	14	190.006.00	2	Copper banjo washer
15	033.028.00	1	Trasmissione idraulica	15	033.028.00	1	Front brake hose
16	017.140.00	2	Cablaggio interruttore stop	16	017.140.00	2	Brake light switch and wire
17	150.179.13	1	Vite fissaggio manubrio	17	150.179.13	1	Clamp bolt
18	184.179.00	2	Vite coperchio pompa	18	184.179.00	2	Master cylinder screw
19	121.133.03	1	Leva sx	19	121.133.03	1	L/h brake lever
20	125.030.00	1	Comando sx completo	20	125.030.00	1	Rear brake (l/h) control assy
21	048.023.03	1	Trasmissione freno posteriore	21	048.023.03	1	Rear brake cable
22	147.078.15	1	Molla freno posteriore	22	147.078.15	1	Rear brake spring
23	119.354.13	1	Barilotto	23	119.354.13	1	Rear brake cable nipple
24	150.175.13	1	Vite regolazione freno	24	150.175.13	1	Rear brake adjusting screw

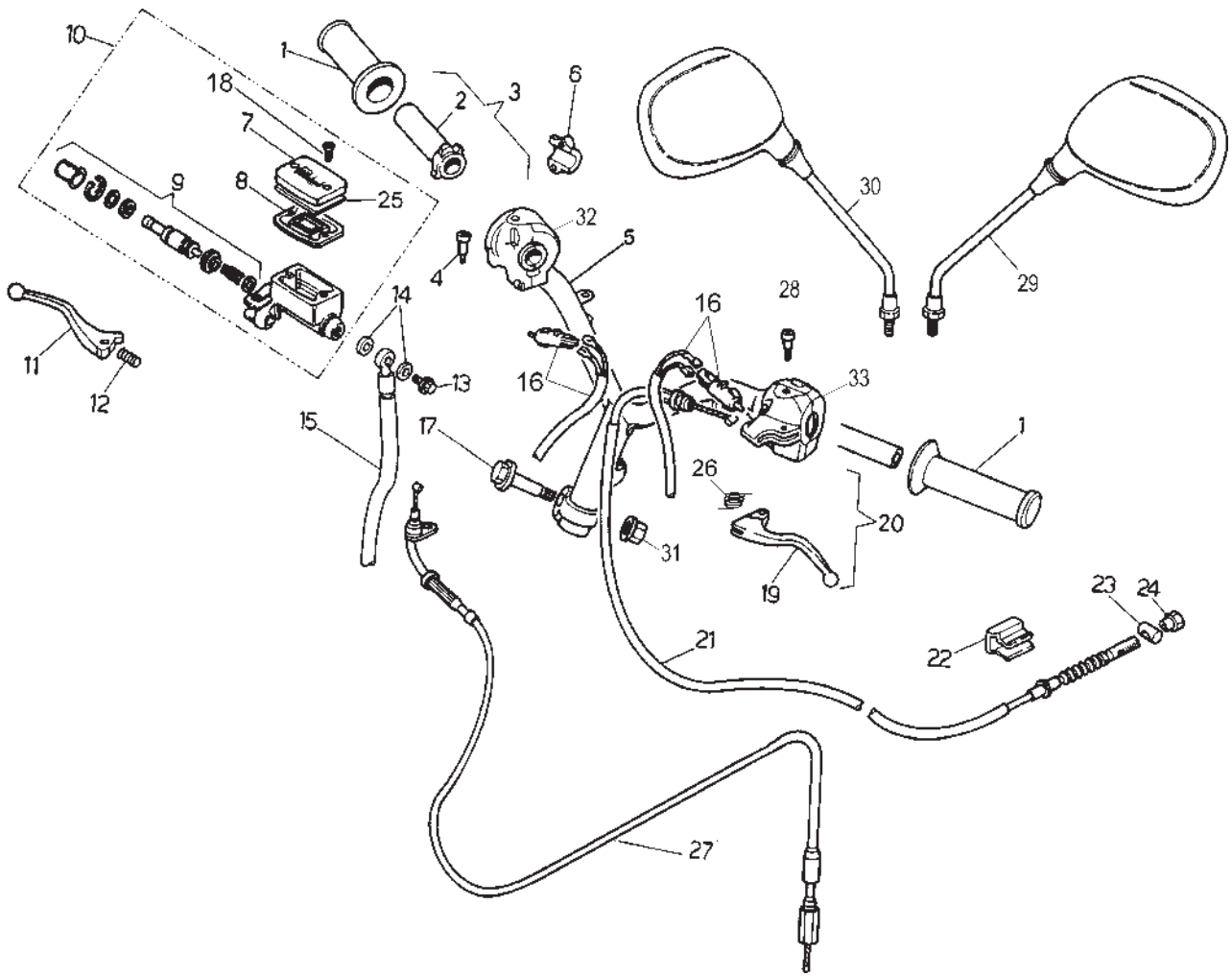

Nr.	Codice	Q.tà	Descrizione
25	121.141.00	1	Guarnizione coperchio
26	121.017.00	1	Molla leva sx
27	034.080.03	1	Trasmissione gas
28	121.136.00	1	Vite fulcro leva sx
29	088.034. --	1	Specchio sx *
30	088.035. --	1	Specchio dx * (di serie mercato estero)
31	184.056.13	1	Dado fissaggio manubrio
32	020.038.00	1	Commutatore dx
33	020.039.00	1	Commutatore sx

No.	Code	Q.ty	Description
25	121.141.00	1	Master cylinder cover seal
26	121.017.00	1	L/h lever spring
27	034.080.03	1	Throttle cable
28	121.136.00	1	L/h lever screw
29	088.034. --	1	L/h mirror *
30	088.035. --	1	R/h mirror * (originally fitted)
31	184.056.13	1	Handlebar fixing clamp nut
32	020.038.00	1	R/h switch
33	020.039.00	1	L/h switch

* Vedi tav. N° OO Colori

* Refer to N° OO - Colour table

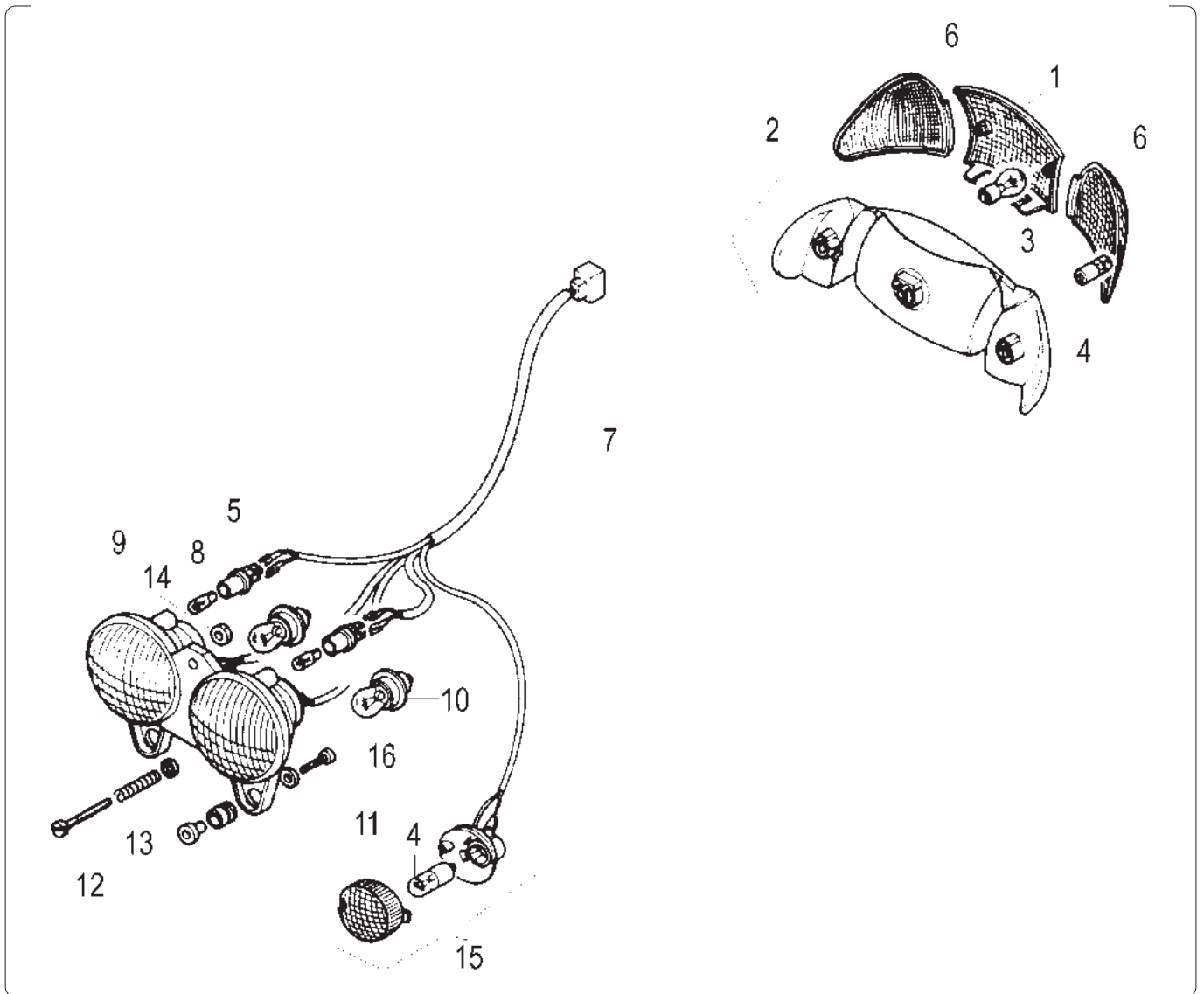

Nr.	Codice	Q.tà	Descrizione
1	016.039.00	1	Vetro fanale posteriore
2	016.037.00	1	Fanale posteriore
3	022.048.00	1	Lampada 12 V - 5 / 21W
4	022.017.00	4	Lampada 12 V - 10 W
5	023.004.00	2	Portalampada
6	019.028.00	2	Vetro indicatori direzione posteriori
7	017.154.00	1	Cablaggio faro anteriore
8	022.047.00	2	Lampadina 12 V - 3 W
9	015.033.00	1	Faro anteriore
10	022.042.00	2	Lampada 12 V - 15 W
11	019.038.00	2	Vetro indicatori direzione anteriori
12	190.004.00	1	Vite regolazione faro
13	147.072.14	1	Molla regolazione faro
14	191.017.13	1	Piastrina regolazione faro
15	019.027.00	2	Indicatore di direzione
16	184.109.13	2	Vite fissaggio faro

No.	Code	Q.ty	Description
1	016.039.00	1	Rear light assembly lens
2	016.037.00	1	Rear light assembly
3	022.048.00	1	12 V - 5 / 21W bulb
4	022.017.00	4	12 V - 10 W bulb
5	023.004.00	2	Bulb holder
6	019.028.00	2	Rear indicators lens
7	017.154.00	1	Front light wiring harness
8	022.047.00	2	12 V - 3 W bulb
9	015.033.00	1	Headlight unit
10	022.042.00	2	12 V - 15 W bulb
11	019.038.00	2	Front indicators lens
12	190.004.00	1	Headlamp adjusting screw
13	147.072.14	1	Headlamp adjusting spring
14	191.017.13	1	Headlamp adjusting plate
15	019.027.00	2	Front indicators
16	184.109.13	2	Headlamp fixing screw

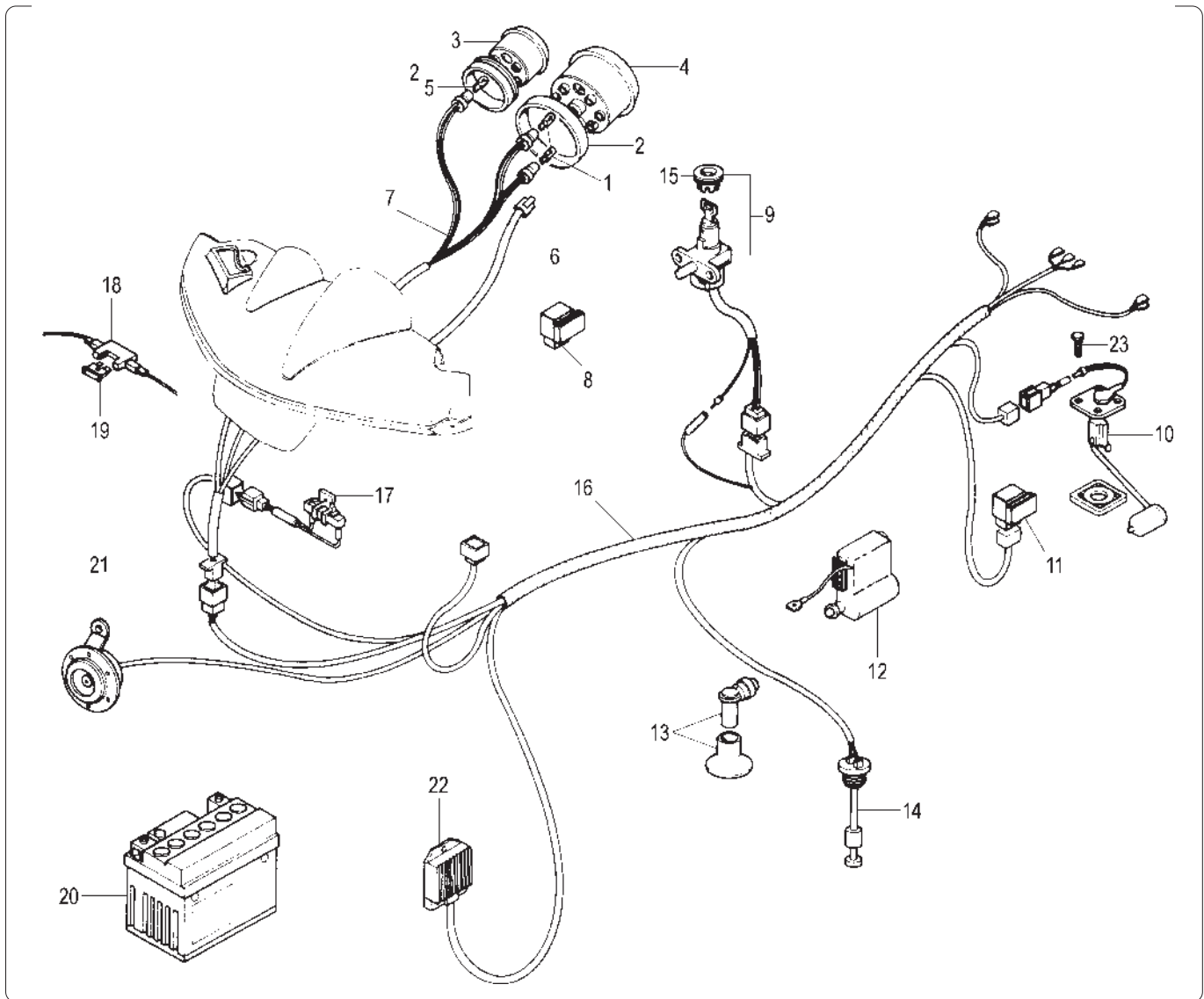

Nr.	Codice	Q.tà	Descrizione
1	022.073.00	2	Lampadina 12 V - 2 W
2	072.059.00	1	Guarnizioni strumenti in coppia
3	178.163.00	1	Orologio benzina
4	178.162.00	1	Orologio kontakm
5	022.036.00	4	Lampadina 12 V - 1,2 W
6	178.116.00	1	Trasmissione kontakm
7	017.227.00	1	Cablaggio cruscotto
8	025.023.00	1	Intermittenza lampeggiatori
9	090.025.00	1	Serratura avviamento
10	093.036.00	1	Sonda livello benzina
11	025.015.00	1	Relais avviamento
12	024.033.00	1	Centralina elettronica
13	073.006.00	1	Pipetta candela con cappuccio
14	093.037.00	1	Sonda livello olio
15	071.163.00	1	Ghiera serratura avviamento
16	017.159.00	1	Cablaggio centrale
17	025.014.00	1	Resistenza
18	025.016.00	1	Portafusibile
19	025.010.00	1	Fusibile 10 A
20	074.018.00	1	Batteria 12 V - 4 Ah
21	018.054.00	1	Avvisatore acustico
22	026.011.00	1	Regolatore di tensione
23	184.009.00	4	Vite fissaggio sonda benzina

No.	Code	Q.ty	Description
1	022.073.00	2	12 V - 2 W bulb
2	072.059.00	1	Fuel gauge rubber seal
3	178.163.00	1	Fuel gauge
4	178.162.00	1	Speedometer
5	022.036.00	4	12 V - 1,2 W bulb
6	178.116.00	1	Speedo cable
7	017.227.00	1	Dashboard wiring
8	025.023.00	1	Flasher unit
9	090.025.00	1	Ignition barrel
10	093.036.00	1	Fuel level gauge
11	025.015.00	1	Starter relay
12	024.033.00	1	CDI
13	073.006.00	1	Spark plug cap
14	093.037.00	1	Oil level gauge
15	071.163.00	1	Ignition lock rim
16	017.159.00	1	Main wiring harness
17	025.014.00	1	Resistor
18	025.016.00	1	Fuse holder
19	025.010.00	1	10 A fuse
20	074.018.00	1	12 V - 4 Ah battery
21	018.054.00	1	Horn
22	026.011.00	1	Regulator
23	184.009.00	4	Fixing screw

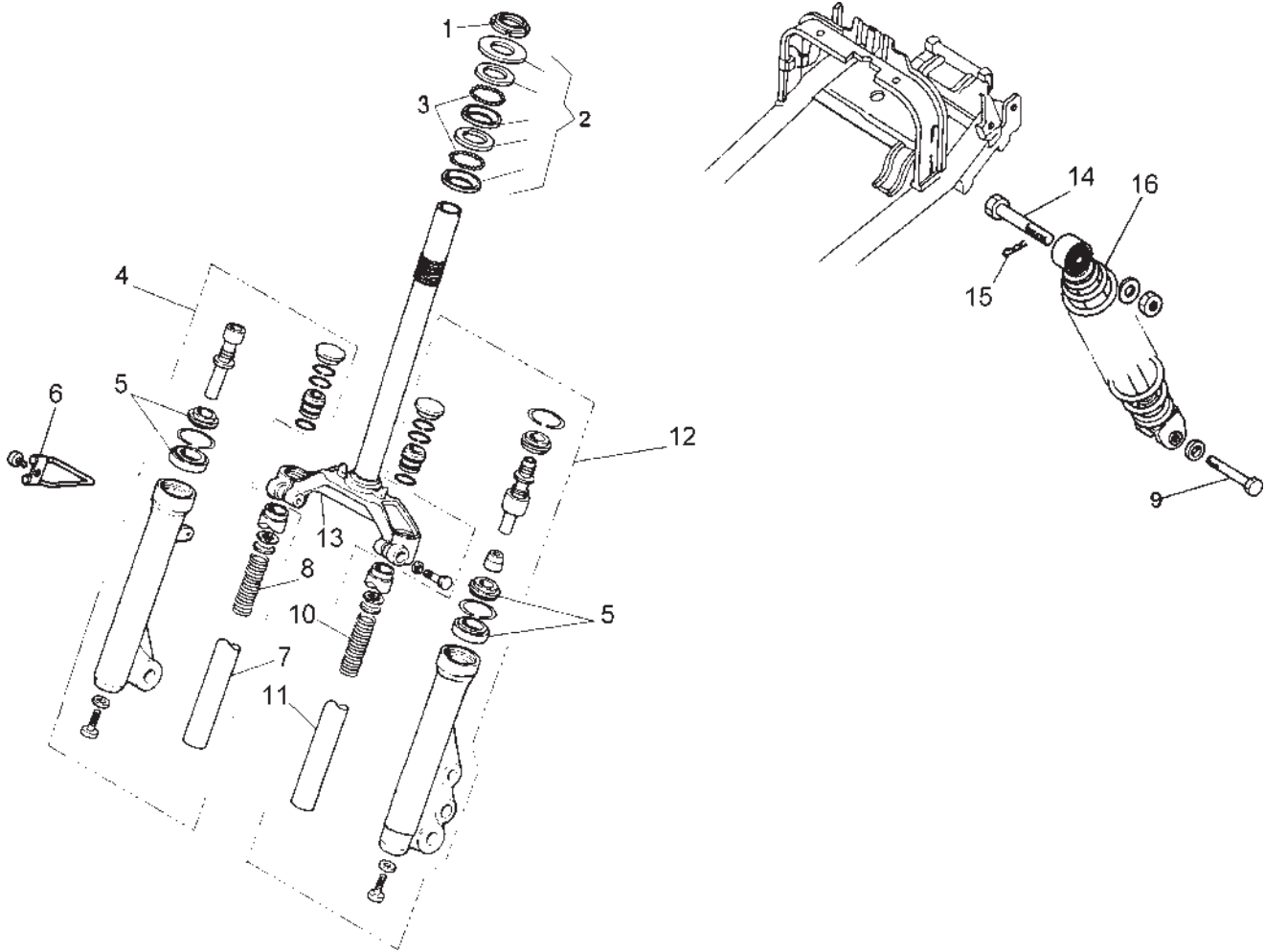

Nr.	Codice	Q.tà	Descrizione
1	185.009.13	1	Ghiera
2	104.014.00	1	Serie sterzo
3	120.261.00	44	Sfere
4	120.294.00	1	Portaruota completo dx
5	120.324.00	1	Paraolio + parapolvere
6	147.075.13	1	Molla passafilo
7	120.286.00	1	Canna dx
8	120.287.00	1	Molla portaruota dx
9	184.038.13	1	Vite fissaggio ammortizzatore
10	120.290.00	1	Molla portaruota sx
11	120.282.00	1	Canna sx
12	120.292.00	1	Portaruota completo sx
13	120.293.99	1	Testa croce
14	184.033.13	1	Vite fissaggio ammortizzatore
15	184.011.00	1	Copiglia
16	010.046.03	1	Ammortizzatore
--	013.028.00	1	Forcella completa

No.	Code	Q.ty	Description
1	185.009.13	1	Steering head nut
2	104.014.00	1	Steering head cap set
3	120.261.00	44	Steering ball cages
4	120.294.00	1	R/h fork leg assy
5	120.324.00	1	Fork bush/seal kit
6	147.075.13	1	Clip
7	120.286.00	1	R/h fork tube
8	120.287.00	1	R/h fork leg spring
9	184.038.13	1	Fixing screw
10	120.290.00	1	L/h fork leg spring
11	120.282.00	1	L/h fork tube
12	120.292.00	1	L/h fork leg assy
13	120.293.99	1	Bottom yoke
14	184.033.13	1	Fixing screw
15	184.011.00	1	Clip
16	010.046.03	1	Rear shock absorber
--	013.028.00	1	Front fork assy

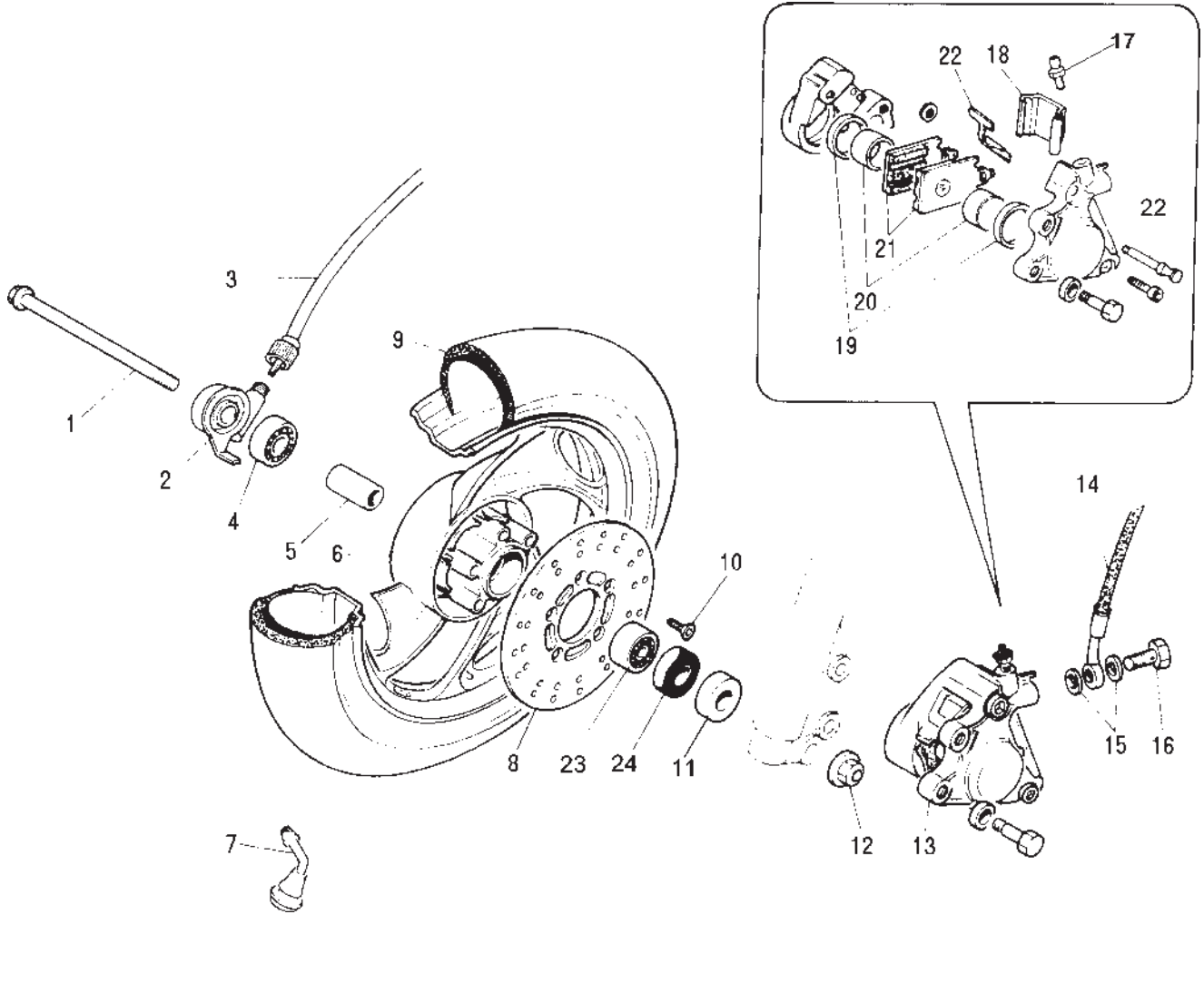
Ruota anteriore e impianto frenante
Front wheel & brake system

Nr.	Codice	Q.tà	Descrizione
1	190.024.00	1	Perno ruota
2	178.078.00	1	Rinvio contakm
3	178.116.00	1	Trasmissione contakm
4	119.438.00	1	Cuscinetto
5	119.437.00	1	Distanziale interno
6	109.047.03	1	Ruota anteriore tubeless
7	094.008.00	1	Valvola tubeless
8	119.398.00	1	Disco freno
9	050.029.00	1	Copertura tubeless 100/80 - 10"
10	184.104.13	5	Vite fissaggio disco freno
11	119.417.00	1	Distanziale
12	185.012.00	1	Dado perno ruota
13	031.019.08	1	Pinza freno idraulica
14	033.028.00	1	Trasmissione idraulica
15	190.006.00	2	Rasamento
16	150.024.14	1	Vite trasmissione idraulica
17	119.436.00	1	Vite spurgo
18	119.434.00	1	Cuffia
19	119.440.00	1	Kit gommini
20	119.435.00	1	Pistoncini
21	119.502.00	1	Coppia pastiglie freno
22	119.457.00	1	Kit perno + molla
23	119.438.00	1	Cuscinetto
24	119.399.00	1	Anello di tenuta

No.	Code	Q.ty	Description
1	190.024.00	1	Front wheel spindle
2	178.078.00	1	Speedo drive
3	178.116.00	1	Speedo cable
4	119.438.00	1	Bearing
5	119.437.00	1	Spacer
6	109.047.03	1	Tubeless front wheel
7	094.008.00	1	Wheel valve
8	119.398.00	1	Front brake disc
9	050.029.00	1	100/80 - 10" tubeless tyre
10	184.104.13	5	Brake disc mounting screw
11	119.417.00	1	Spacer
12	185.012.00	1	Nut
13	031.019.08	1	Front brake caliper
14	033.028.00	1	Front brake hose
15	190.006.00	2	Copper banjo washer
16	150.024.14	1	Banjo bolt
17	119.436.00	1	Screw
18	119.434.00	1	Brake pad cover
19	119.440.00	1	Front brake caliper seal kit
20	119.435.00	1	Front brake pistons
21	119.502.00	1	Brake pads
22	119.457.00	1	Support pads set
23	119.438.00	1	Bearings
24	119.399.00	1	Seal ring

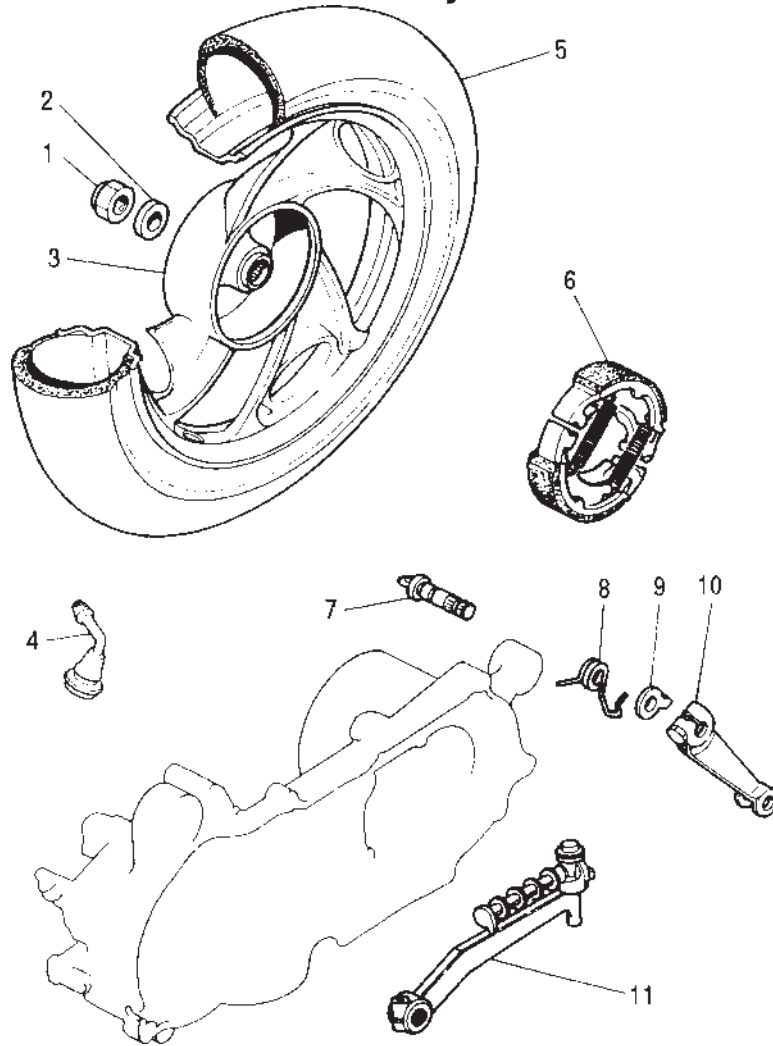
Ruota posteriore e impianto frenante
Rear wheel & brake system

Nr.	Codice	Q.tà	Descrizione
1	185.010.00	1	Dado ruota posteriore
2	119.224.00	1	Rondella
3	110.047.03	1	Ruota posteriore tubeless
4	094.008.00	1	Valvola tubeless
5	050.029.00	1	Copertura 100/80 - 10" tubeless
6	119.403.00	1	Ceppi freno posteriori
7	119.351.00	1	Ogiva
8	119.353.13	1	Molla leva freno
9	191.016.13	1	Piastrina ferodi
10	119.352.00	1	Leva freno
11	081.009.03	1	Leva messa in moto

No.	Code	Q.ty	Description
1	185.010.00	1	Rear wheel nut
2	119.224.00	1	Washer
3	110.047.03	1	Tubeless rear wheel
4	094.008.00	1	Wheel valve
5	050.029.00	1	100/80 - 10" tubeless tyre
6	119.403.00	1	Rear brake shoes
7	119.351.00	1	Cam
8	119.353.13	1	Return spring
9	191.016.13	1	Rear brake adjustment washer
10	119.352.00	1	Brake lever
11	081.009.03	1	Kick-starter lever



TABELLA COLORI - COLOUR CODES

Colori - Colours

N° No.	Codice Code	34	44	72	77	91	73	94	97	53	67
		Blu Opaco Mat blue	Blu Elettrico Electric blue	Bianco White	Argento Lucido Bright silver	Magenta Mag. red	Nero Velvet Velvet black	Blu Notte Dark Blue	Titanio Titanium	Fast Time Fast Time	Arg. Eco Silver
1	063.078.	34	44	72	77	91	73	94	97	03	67
2	063.079.	34	44	72	77	91	73	94	97	53	67
3	063.083.	34	44	72	77	91	73	94	97	03	67
4	066.042.	34	44	72	77	91	73	94	97	53	67
5	071.284.	34	44	72	77	91	73	94	97	03	67
6	071.147.	34	44	72	77	91	73	94	97	03	67
7	063.080.	34	44	72	77	91	73	94	97	03	67
8	088.034.	34	44	72	87	91	93	94	98	93	87
9	088.035.	34	44	72	87	91	93	94	98	93	87
--	181.319.	03	00	00	00	00	03	00	00	53	00
--	181.321.	03	00	00	00	00	03	00	00	53	00

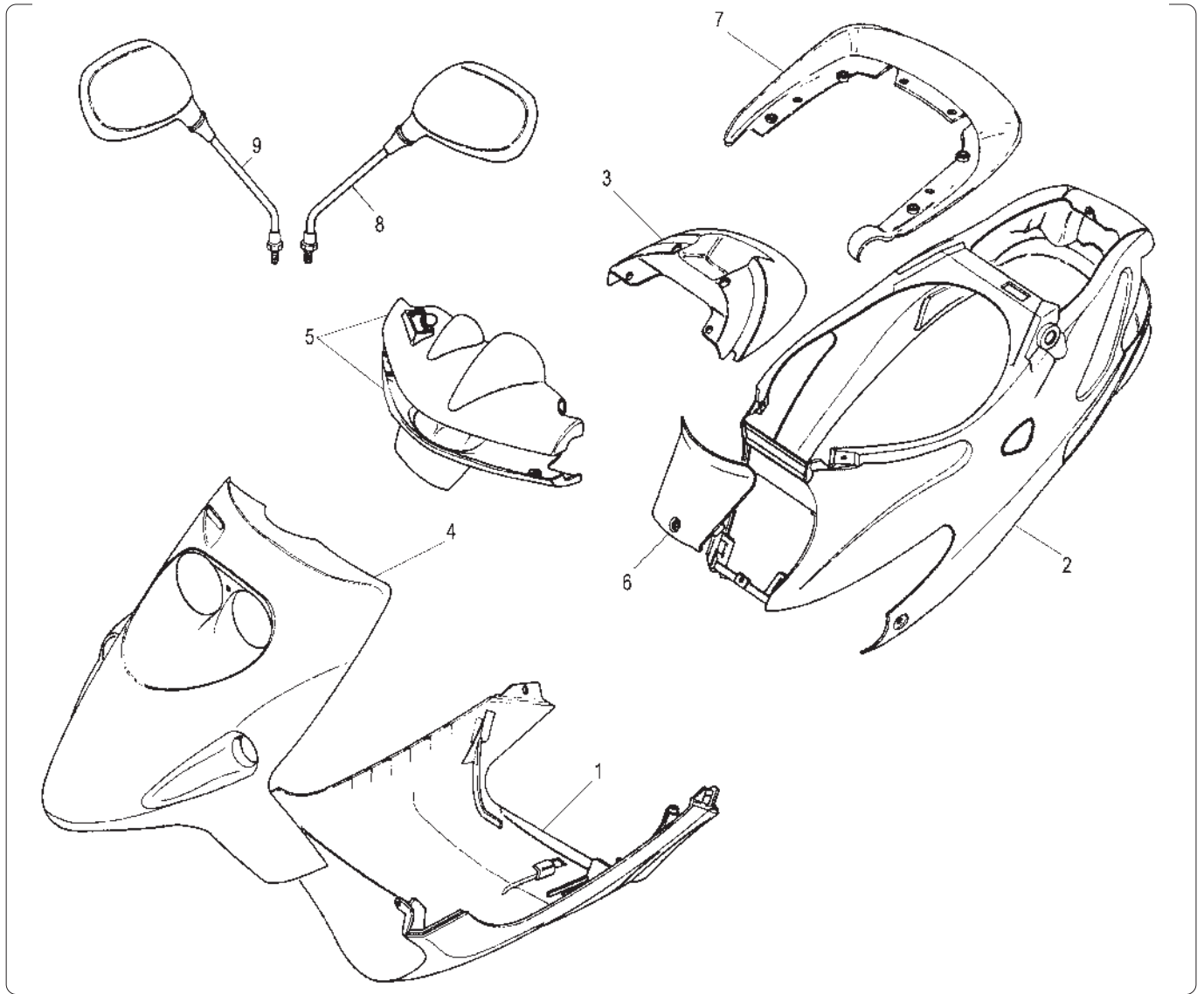
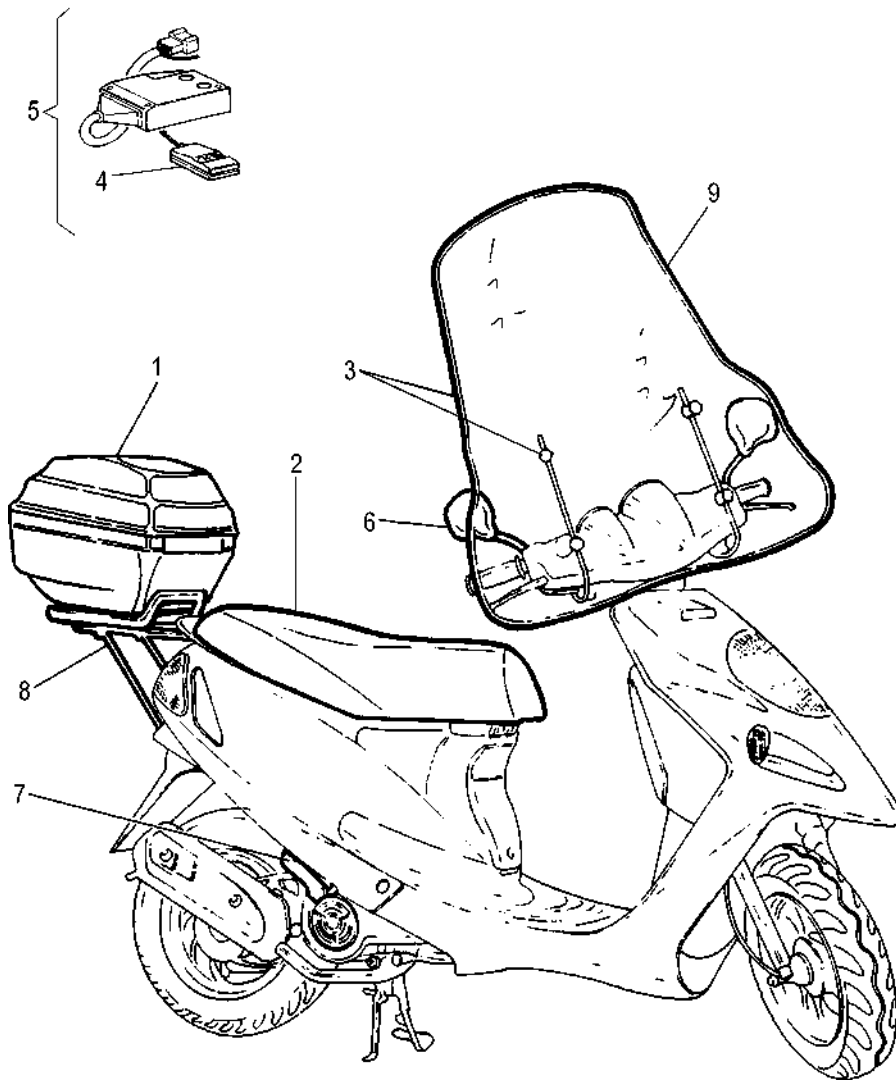

Nr.	Codice	Q.tà	Descrizione
1	065.072.03	1	Bauletto porta oggetti
2	106.064.03	1	Sella biposto
3	063.084.00	1	Parabrezza
4	018.079.00	1	Radiocomando
5	018.078.00	1	Antifurto + cablaggio
6	088.035. --	1	Specchio dx * (di serie mercato estero)
7	084.028.00	1	Staffe pedane secondo passeggero
8	173.046.00	1	Portapacchi completo
9	063.143.00	1	Lastra parabrezza
--	065.027.00	1	Coprimoto scooter standard
--	065.077.00	1	Coprimoto scooter con accessori

Nr.	Code	Q.ty	Description
1	065.072.03	1	Top case
2	106.064.03	1	Long seat
3	063.084.00	1	Windscreen
4	018.079.00	1	Remote control
5	018.078.00	1	Alarm complete
6	088.035. --	1	R/h mirror * (originally fitted)
7	084.028.00	1	Footrests
8	173.046.00	1	Rear carrier
9	063.143.00	1	Windscreen glass
--	065.027.00	1	Scooter canvas cover
--	065.077.00	1	Accessoried scooter canvas cover

* Vedi tav. N° OO Colori

* Refer to N° OO - Colour table

Scooter F 10 WAP Restyling KAT EURO 1 Motore CY 50 - CY 50 engine

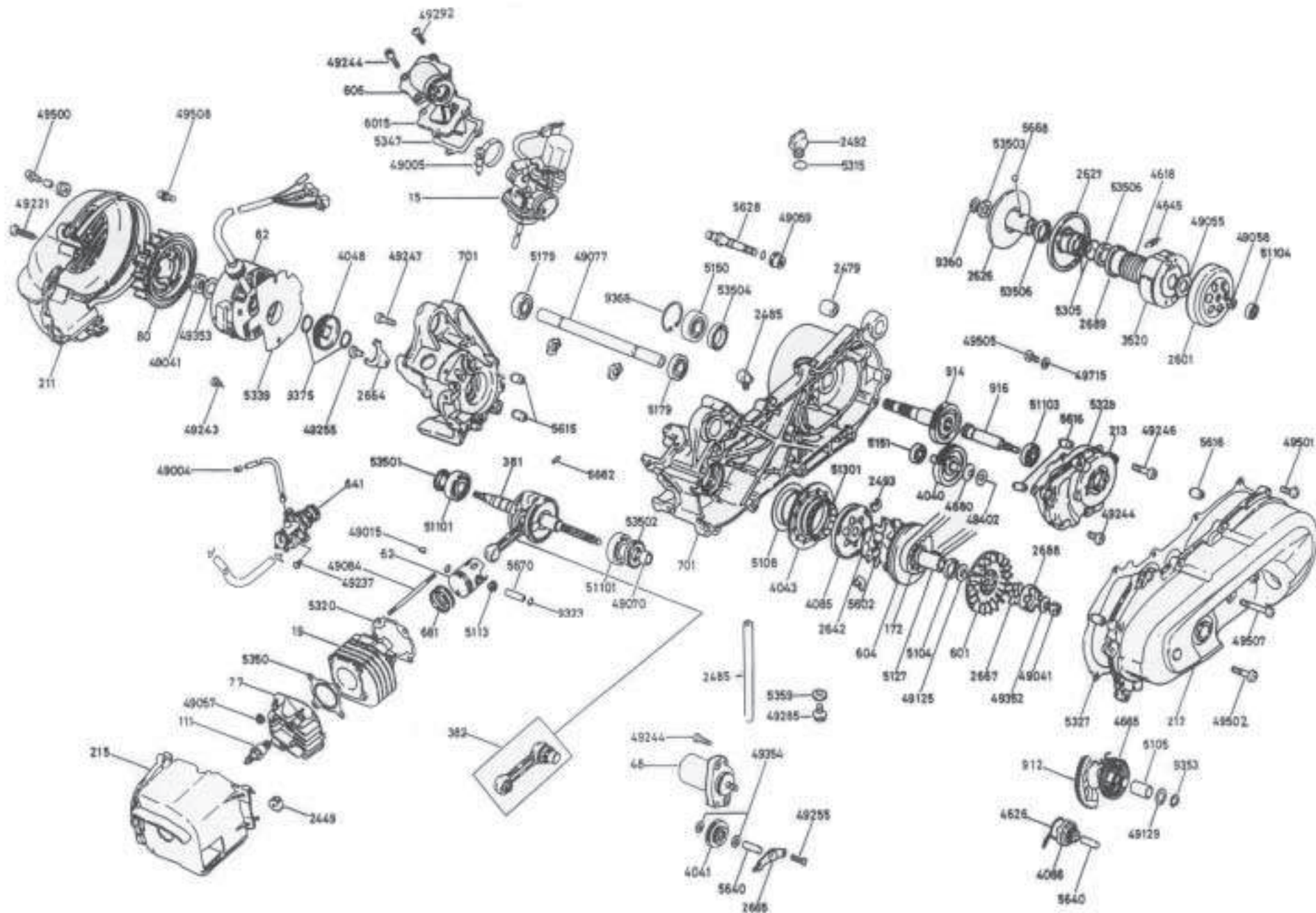

Nr.	Codice	Q.tà	Descrizione	Nr.	Code	Q.ty	Description
15	715.091.00	1	Carburatore Gurtner PY 12 / R 406	15	715.091.00	1	Carburettor Gurtner PY 12 / R 406
19	771.125.00	1	Cilindro completo di pistone	19	771.125.00	1	Cylinder assy
48	024.044.00	1	Motorino avviamento	48	024.044.00	1	Starter motor
62	771.116.00	1	Pistone completo Ø 40	62	771.116.00	1	Piston assy Ø 40
77	777.014.00	1	Testa	77	777.014.00	1	Cylinder head
80	780.003.00	1	Ventola	80	780.003.00	1	Fan
82	782.018.00	1	Volano magnete	82	782.018.00	1	Magneto flywheel assy
111	711.008.00	1	Candela	111	711.008.00	1	Spark plug
172	717.006.00	1	Cinghia di trasmissione	172	717.006.00	1	V-belt
211	721.067.00	1	Convogliatore ventola	211	721.067.00	1	Air shroud (outer)
212	721.052.00	1	Coperchio messa in moto (nero)	212	721.052.00	1	Case cover
213	721.053.00	1	Coperchio trasmissione	213	721.053.00	1	Gear cover
215	721.054.00	1	Cuffia convogliatore cilindro	215	721.054.00	1	Air shroud (inner)
381	771.117.00	1	Imbiellaggio	381	771.117.00	1	Crankshaft
382	771.118.00	1	Biella completa	382	771.118.00	1	Connecting rod
601	760.043.00	1	Puleggia anteriore fissa	601	760.043.00	1	Primary fixed pulley
604	760.044.00	1	Puleggia anteriore mobile con boccola	604	760.044.00	1	Primary pulley
606	760.045.00	1	Collettore aspirazione	606	760.045.00	1	Intake manifold
641	764.006.00	1	Pompa olio completa	641	764.006.00	1	Oil pump assy
681	771.120.00	1	Serie segmenti Ø 40	681	771.120.00	1	Piston ring set Ø 40
701	770.018.00	1	Coppia carter motore	701	770.018.00	1	Crankcase set
912	701.041.00	1	Albero messa in moto	912	701.041.00	1	Kick start shaft
914	701.042.00	1	Albero uscita moto completo Z = 36	914	701.042.00	1	Drive shaft assy Z=46
916	701.043.00	1	Albero trasmissione Z = 13	916	701.043.00	1	Gear shaft Z=13
2449	724.044.00	2	Gommino supporto convogliatore cilindro	2449	724.044.00	2	Cylinder cover grommet
2479	724.045.00	1	Gommino silentblock carter	2479	724.045.00	1	Rubber
2485	724.047.00	1	Raccordo plastica sfiato olio	2485	724.047.00	1	Oil breather pipe
2492	724.048.00	1	Tappo alimentazione olio	2492	724.048.00	1	Oil plug
2493	724.049.00	3	Tassello di traino	2493	724.049.00	3	Dowels
2601	726.017.00	1	Campana frizione	2601	726.017.00	1	Clutch housing
2626	726.018.00	1	Puleggia secondaria fissa completa	2626	726.018.00	1	Secondary fixed pulley
2627	726.019.00	1	Puleggia secondaria mobile completa	2627	726.019.00	1	Secondary pulley
2642	726.020.00	1	Cappellotto porta tasselli	2642	726.020.00	1	Dowelholder cap
2664	726.021.00	1	Piastrina ritegno paraolio	2664	726.021.00	1	Plate
2665	726.022.00	1	Piastrina ingranaggio doppio intermedio E/S	2665	726.022.00	1	Idle gear plate
2667	726.023.00	1	Piastrina traino puleggia anteriore fissa	2667	726.023.00	1	Drive pulley lock washer
2688	726.026.00	1	Scodellino dentato messa in moto	2688	726.026.00	1	Drive plate
2689	726.025.00	1	Scodellino portamolla variatore	2689	726.025.00	1	Spring holder
3520	735.030.00	1	Frizione centrifuga completa	3520	735.030.00	1	Clutch assy
4040	740.120.00	1	Ingranaggio doppio intermedio Z = 12/48	4040	740.120.00	1	Idle gear assy Z=12/48
4041	740.121.00	1	Ingranaggio doppio intermedio E/S	4041	740.121.00	1	Idle gear assy E/S
4043	740.122.00	1	Corona avviamento elettrico Z = 71	4043	740.122.00	1	Kick start gear Z=71
4048	740.123.00	1	Ingranaggio conduttore pompa olio	4048	740.123.00	1	Pump drive gear
4066	740.124.00	1	Ingranaggio scorrevole messa in moto	4066	740.124.00	1	Kick start pinion gear

Nr.	Codice	Q.tà	Descrizione	Nr.	Code	Q.ty	Description
4085	740.125.00	1	Ruota libera completa	4085	740.125.00	1	Free wheel assy
4618	746.039.00	1	Molla puleggia secondaria mobile	4618	746.039.00	1	Secondary pulley spring
4626	746.040.00	1	Molla scorrevole messa in moto	4626	746.040.00	1	Kick start thrust spring
4645	746.050.00	2	Molla richiamo ceppi frizione	4645	746.050.00	2	Clutch pad spring
4665	746.042.00	1	Molla ritorno leva messa in moto	4665	746.042.00	1	Kick start return spring
4680	746.043.00	1	Molla a disco ingranaggio doppio intermedio	4680	746.043.00	1	Idle gear spring
5104	751.062.00	1	Distanziale Ø 18 x 23 x 5,5	5104	751.062.00	1	Spacer Ø 18 x 23 x 5,5
5105	751.041.00	1	Boccola albero messa in moto Ø 15 x 20 x 30	5105	751.041.00	1	Kick start shaft bush Ø 15 x 20 x 30
5108	751.042.00	1	Boccola flangiata corona E/S	5108	751.042.00	1	Bush
5113	751.043.00	1	Gabbia KBK Ø 10 x 14 x 12,5	5113	751.043.00	1	Cage KBK Ø 10 x 14 x 12,5
5127	751.045.00	1	Boccola puleggia anteriore mobile	5127	751.045.00	1	Primary pulley bush
5150	751.046.00	1	Cuscinetto Ø 17 x 40 x 12 (6203 - 2RS1)	5150	751.046.00	1	Bearing Ø 17 x 40 x 12 (6203 - 2RS1)
5151	751.047.00	1	Cuscinetto Ø 10 x 30 x 9 (6200 - C3)	5151	751.047.00	1	Bearing Ø 10 x 30 x 9 (6200 - C3)
5179	751.049.00	2	Cuscinetto Ø 17 x 35 x 10 stagno (6003 - 2RS)	5179	751.049.00	2	Bearing Ø 17 x 35 x 10 (6003 - 2RS)
5305	753.104.00	2	Anello di tenuta OR Ø 37,85 x 1,7	5305	753.104.00	2	Oil seal OR Ø 37,85 x 1,7
5315	753.105.00	1	Anello di tenuta OR Ø 13,8 x 2,4	5315	753.105.00	1	Oil seal OR Ø 13,8 x 2,4
5320	753.106.00	1	Guarnizione base cilindro	5320	753.106.00	1	Cylinder base gasket
5327	753.107.00	1	Guarnizione coperchio messa in moto	5327	753.107.00	1	Sidecase gasket
5328	753.108.00	1	Guarnizione coperchio trasmissione	5328	753.108.00	1	Gear box gasket
5339	753.109.00	1	Guarnizione statore volano magnete	5339	753.109.00	1	Stator gasket
5347	753.110.00	1	Guarnizione valvola lamelle	5347	753.110.00	1	Reed valve gasket
5350	753.111.00	1	Guarnizione testa	5350	753.111.00	1	Head gasket
5359	753.112.00	1	Guarnizione vite scarico olio	5359	753.112.00	1	Oil drain plug gasket
5602	756.083.00	6	Massa centrifuga Ø 8,8	5602	756.083.00	6	Centrifugal roller Ø 8,8
5615	756.029.00	2	Grano riferimento carter	5615	756.029.00	2	Crankcase locating dowel
5616	756.030.00	4	Grano riferimento coperchi	5616	756.030.00	4	Gearbox locating dowel
5628	756.069.00	1	Perno ceppi freno	5628	756.069.00	1	Pin
5640	756.070.00	2	Perno Ø 8 x 32	5640	756.070.00	2	Pin Ø 8 x 32
5662	756.071.00	1	Rullo Ø 3 x 11,8	5662	756.071.00	1	Pin Ø 3 x 11,8
5668	756.072.00	2	Rullino di guida variatore	5668	756.072.00	2	Pin guide
5670	756.073.00	1	Spinotto Ø 10 x 33	5670	756.073.00	1	Pin Ø 10 x 33
6015	760.046.00	1	Valvola lamelle completa	6015	760.046.00	1	Reed valve assy
9323	703.028.00	2	Anello di fermo spinotto Ø 11,8	9323	703.028.00	2	Circlip Ø 11,8
9353	703.005.00	1	Anello seeger per albero Ø 15	9353	703.005.00	1	Kick start circlip A Ø 15
9360	703.023.00	3	Anello seeger per albero Ø 17	9360	703.023.00	3	Engine pivot circlip Ø 17
9368	703.025.00	1	Anello seeger per foro Ø 40	9368	703.025.00	1	Wheel bearing circlip Ø 40
9375	703.026.00	2	Anello seeger per albero Ø 19	9375	703.026.00	2	Oil pump circlip Ø 19
49004	749.180.00	1	Fascetta tubo pompa olio	49004	749.148.00	1	Clamp
49005	749.270.00	1	Fascetta antimanomissione flangia aspirazione	49005	749.180.00	1	Antitampering clamp
49015	749.107.00	1	Chiavetta volano magnete	49015	749.107.00	1	Woodruff key
49040	749.210.00	1	Dado M10 x 1,25	49040	749.210.00	1	Nut M10 x 1,25
49041	749.181.00	1	Dado M10 x 1,25 - H = 8	49041	749.181.00	1	Nut M10 x 1,25 - H = 8
49055	749.182.00	1	Dado M28 x 1 - (CH = 41) - H = 4	49055	749.182.00	1	Nut M28 x 1 - (CH = 41) - H = 4
49057	749.183.00	4	Dado M7 x 1 fissaggio testa	49057	749.183.00	4	Nut M7 x 1

Nr.	Codice	Q.tà	Descrizione
49058	749.184.00	1	Dado M10 x 1 - (CH = 24) - H = 5,8
49059	749.185.00	1	Dado M8 x 1,25 flangiato perno ceppi freno
49070	749.186.00	1	Distanziale cuscinetto paraolio frizione
49077	749.187.00	1	Distanziale attacco carter
49084	749.188.00	4	Prigioniero fissaggio testa M7 x 1 x 109
49125	749.222.00	1	Rondella acciaio blu Ø 13,2 x 20 x1,3
49129	749.189.00	1	Rondella acciaio blu Ø 15,1 x 28 x 1
49221	749.190.00	1	Vite autofilettante convogliatore ventola
49237	749.095.00	2	Vite T.C.C.E. M5 x 14
49243	749.036.00	2	Vite T.C.C.E. M6 x 16
49244	749.037.00	9	Vite T.C.C.E. M6 x 20
49247	749.039.00	8	Vite T.C.C.E. M6 x 35
49255	749.176.00	3	Vite T.C.C.E. M6 x 12
49285	749.191.00	1	Vite TE M8 x 1,25 x 15 scarico olio
49292	184.218.00	3	Vite antimanomissione M6
49352	749.192.00	1	Rondella conica scodellino messa in moto
49353	749.193.00	1	Rondella Ø 10,5 x 18 x 2
49354	749.194.00	2	Rondella Ø 8 x 16 x 2
49402	749.195.00	1	Rondella acciaio blu Ø 12,1 x 25,8 x 1,2
49500	749.196.00	2	Vite T.C.C.E. M6 x 20 con rondella (nera)
49501	749.197.00	8	Vite T.C.C.E. M6 x 25 (nera)
49502	749.207.00	2	Vite T.C.C.E. M6 x 35 (nera)
49505	749.198.00	1	Vite T.C.C.E. M6 x 10
49507	749.200.00	1	Vite T.C.C.E. M6 x 60 (nera)
49508	749.201.00	3	Vite T.C.C.E. M6 x 60 con rondelle
49715	749.202.00	1	Rondella Ø 6,5 x 18 x 1,5
51101	751.066.00	2	Cuscinetto Ø 20 x 47 x 14 (6204)
51103	751.051.00	1	Cuscinetto Ø 17 x 35 x 10 (6003)
51104	751.052.00	1	Cuscinetto Ø 8 x 28 x 9 (638 - ZC3)
51301	751.053.00	1	Gabbia Ø 57 x 61 x 10 (57RFN - 6110A)
53501	753.115.00	1	Paraolio Ø 20 x 30/34 x 5/6,1
53502	753.116.00	1	Paraolio Ø 20 x 42/43 x 8/9
53503	753.117.00	1	Paraolio Ø 17 x 28 x 5,5
53504	753.118.00	1	Paraolio Ø 22 x 32 x 6
53506	753.119.00	2	Paraolio Ø 33 x 39 x 4
--	740.146.00	1	Gruppo variatore con frizione
--	771.124.00	1	Serie paraoli CY 50
--	799.065.00	1	Serie guarnizioni
--	771.121.00	1	Pistone completo Ø 40,5 - 1° maggiorazione
--	771.121.01	1	Pistone completo Ø 41 - 2° maggiorazione
--	771.122.00	1	Serie segmenti Ø 40,5 - 1° maggiorazione
--	771.122.01	1	Serie segmenti Ø 41 - 2° maggiorazione
--	142.110.03	1	Motore completo EURO 1

Nr.	Code	Q.ty	Description
49058	749.184.00	1	Nut M10 x 1 - (CH = 24) - H = 5,8
49059	749.185.00	1	Brake shaft nut M8 x 1,25
49070	749.186.00	1	Spacer
49077	749.187.00	1	Spacer
49084	749.188.00	4	Cylinder head stud
49125	749.222.00	1	Washer Ø 13,2 x 20 x1,3
49129	749.189.00	1	Washer Ø 15,1 x 28 x 1
49221	749.190.00	1	Screw
49237	749.095.00	2	ScrewM5 x 14
49243	749.036.00	2	Screw M6 x 16
49244	749.037.00	9	Screw M6 x 20
49247	749.039.00	8	Screw M6 x 35
49255	749.176.00	3	Screw M6 x 12
49285	749.191.00	1	Oil drain plug M8 x 1,25 x 15
49292	184.218.00	3	Antitampering screw
49352	749.192.00	1	Washer
49353	749.193.00	1	Washer Ø 10,5 x 18 x 2
49354	749.194.00	2	Washer Ø 8 x 16 x 2
49402	749.195.00	1	Washer Ø 12,1 x 25,8 x 1,2
49500	749.196.00	2	Screw M6 x 20 with washer (black)
49501	749.197.00	8	Screw M6 x 25 (black)
49502	749.207.00	2	Screw M6 x 35 (black)
49505	749.198.00	1	Screw M6 x 10
49507	749.200.00	1	Screw M6 x 60 (black)
49508	749.201.00	3	Screw M6 x 60 with washer
49715	749.202.00	1	Washer Ø 6,5 x 18 x 1,5
51101	751.066.00	2	Bearing Ø 20 x 47 x 14 (6204)
51103	751.051.00	1	Bearing Ø 17 x 35 x 10 (6003)
51104	751.052.00	1	Bearing Ø 8 x 28 x 9 (638 - ZC3)
51301	751.053.00	1	Roller bearing Ø 57 x 61 x 10 (57RFN - 6110A)
53501	753.115.00	1	Oil seal Ø 20 x 30/34 x 5/6,1
53502	753.116.00	1	Oil seal Ø 20 x 42/43 x 8/9
53503	753.117.00	1	Oil seal Ø 17 x 28 x 5,5
53504	753.118.00	1	Oil seal Ø 22 x 32 x 6
53506	753.119.00	2	Oil seal Ø 33 x 39 x 4
--	740.146.00	1	Variable transmission clutch set
--	771.124.00	1	Oil seal set
--	799.065.00	1	Gasket set
--	771.121.00	1	Piston assy Ø 40,5 - 1°
--	771.121.01	1	Piston assy Ø 41 - 2°
--	771.122.00	1	Piston ring set Ø 40,5 - 1°
--	771.122.01	1	Piston ring set Ø 41 - 2°
--	142.110.03	1	Engine assy EURO 1

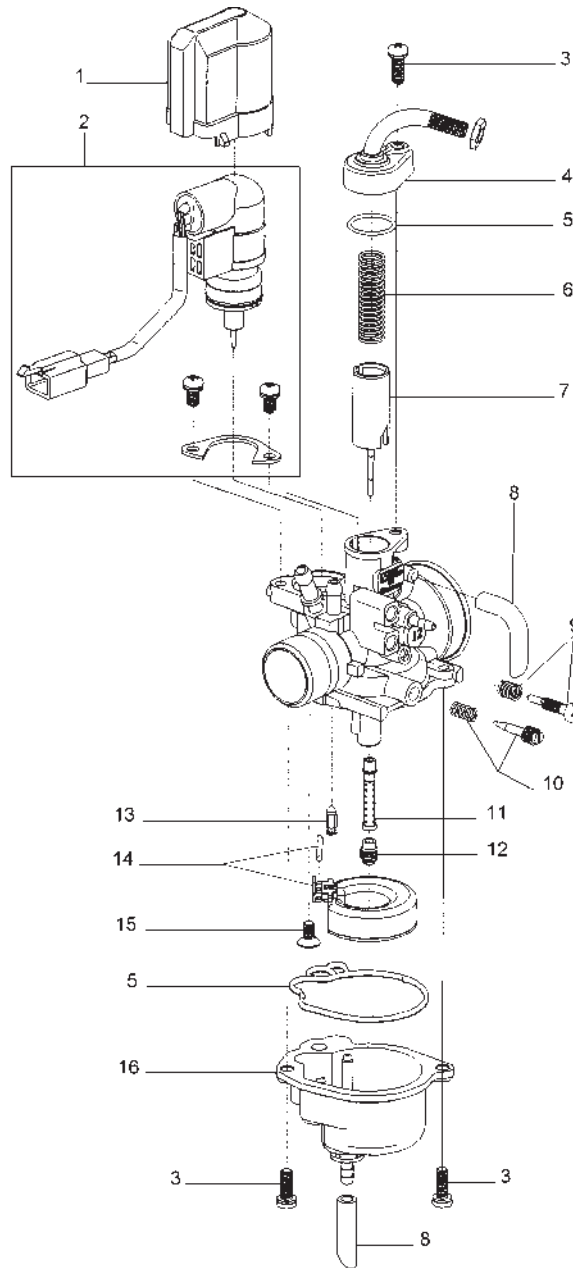

Nr.	Codice	Q.tà	Descrizione	No.	Code	Q.ty	Description
01	623.101.00	1	Cappuccio	01	623.101.00	1	Cap
02	623.120.00	1	Starter completo	02	623.120.00	1	Starter, complete
03	623.106.00	3	Vite	03	623.106.00	3	Screw
04	623.117.00	1	Coperchio completo	04	623.117.00	1	Cover, complete
05	623.119.00	1	Kit guarnizioni	05	623.119.00	1	Gasket set
06	623.098.00	1	Molla valvola gas	06	623.098.00	1	Throttle valve spring
07	623.110.00	1	Valvola gas completa	07	623.110.00	1	Throttle valve, complete
08	623.124.00	1	Kit tubi sfiato - presa aria	08	623.124.00	1	Breather pipe/air intake kit
09	623.121.00	1	Vite regolazione valvola gas	09	623.121.00	1	Throttle valve adj. screw
10	623.122.00	1	Vite regolazione minimo	10	623.122.00	1	Idling mix adjusting screw
11	623.113.00	1	Polverizzatore	11	623.113.00	1	Spray nozzle
12	623.145.00	1	Getto max. Ø 66	12	623.145.00	1	Max. jet Ø 66
13	623.114.00	1	Valvola a spillo	13	623.114.00	1	Needle valve
14	623.123.00	1	Galleggiante completo	14	623.123.00	1	Float assy
15	623.107.00	1	Vite fissaggio galleggiante	15	623.107.00	1	Float clamp screw
16	623.116.00	1	Vaschetta completa	16	623.116.00	1	Float chamber, complete
--	715.091.00	1	Carburatore completo Gurtner PY 12 / R 406	--	715.091.00	1	Carburettor assy Gurtner PY 12 / R 406