



Malaguti
IDEE IN MOTO

CIAK MASTER 50 - 2 TEMPI EURO 2-2006



TELAIO - INDICE TAVOLE

FRAME - INDEX OF THE TABLES

TAV. A 	TAV. C 	TAV. D 	TAV. E 	TAV. F
TAV. G 	TAV. H 	TAV. I 	TAV. L 	TAV. M
TAV. N 	TAV. OO 	TAV. O 		

MOTORE - INDICE TAVOLE

ENGINE - INDEX OF THE TABLES

TAV. R 	TAV. R1 			
------------	-------------	--	--	--

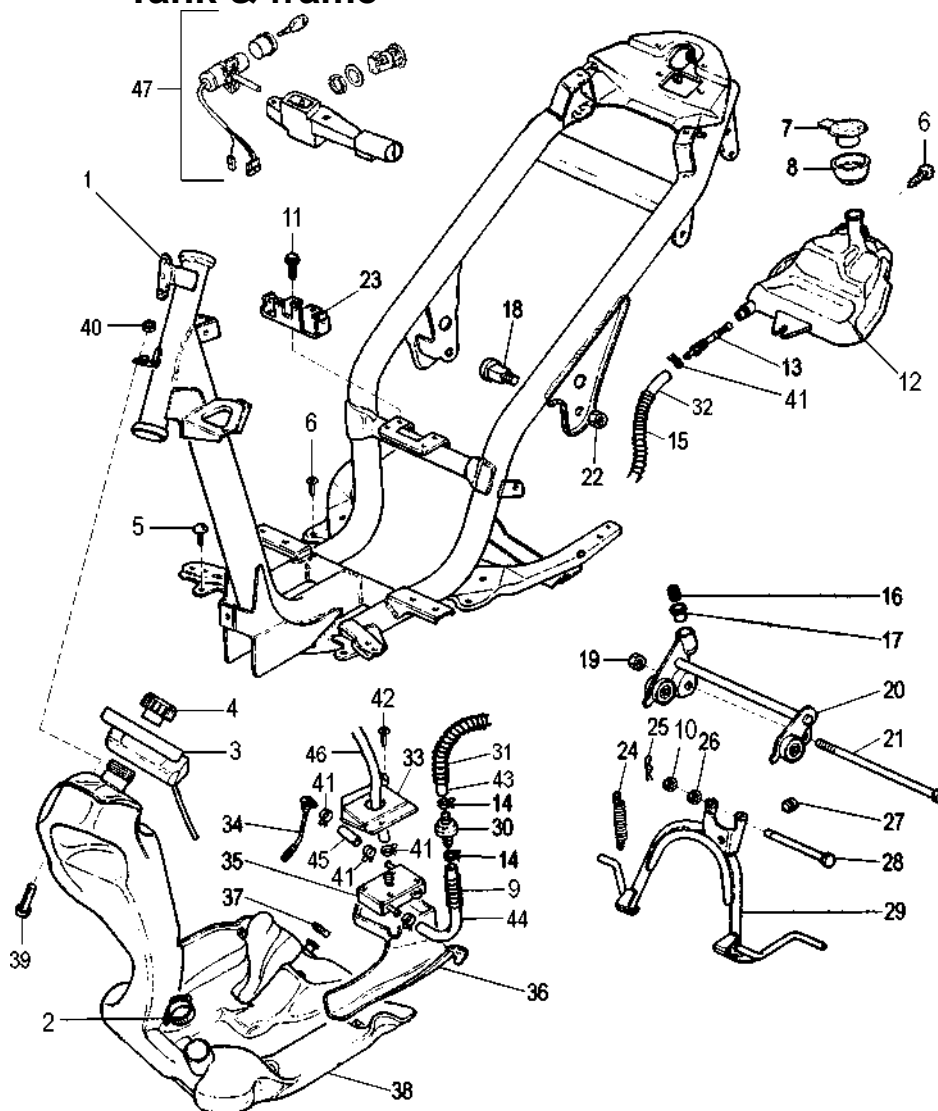
Telaio e serbatoio
Tank & frame

Nr.	Codice	Q.tà	Descrizione
1	156.097.99	1	Telaio
2	167.045.00	1	Fascetta sonda benzina
3	071.306.03	1	Raccogli gocce
4	092.030.00	1	Tappo serbatoio benzina
5	072.106.07	2	Gommino antivibrante serbatoio
6	184.254.15	3	Vite fissaggio serbatoio
7	071.144.00	1	Tappo serbatoio olio
8	071.339.03	1	Vaschetta raccogli gocce olio
9	147.089.13	1	Molla protezione tubo benzina
10	184.180.14	1	Rondella cavalletto
11	184.036.14	1	Vite
12	069.020.00	1	Serbatoio olio
13	094.007.00	1	Raccordo olio
14	167.018.13	2	Fascetta valvola benzina
15	147.122.13	1	Molla protezione tubo olio
16	147.106.14	1	Molla antivibrazione
17	080.010.00	1	Porta molla in gomma
18	190.020.13	2	Perno supporto motore
19	185.011.00	1	Dado fulcro motore
20	174.029.99	1	Attacco motore completo
21	190.040.13	1	Perno motore
22	185.012.00	2	Dado fulcro bilanciere
23	310.579.13	1	Piastrina componenti elettrici
24	147.109.13	1	Molla doppia cavalletto
25	184.011.00	1	Copiglia

Nr.	Code	Q.ty	Description
1	156.097.99	1	Frame
2	167.045.00	1	Clamp
3	071.306.03	1	Fuel tank box
4	092.030.00	1	Fuel tank cap
5	072.106.07	2	Rubber grommet
6	184.254.15	3	Fuel tank fixing screws
7	071.144.00	1	Oil tank cap
8	071.339.03	1	Oil tank box
9	147.089.13	1	Fuel pipe spring
10	184.180.14	1	Main stand washer
11	184.036.14	1	Screw
12	069.020.00	1	Oil tank
13	094.007.00	1	Oil pipe connector
14	167.018.13	2	Fuel valve clamp
15	147.122.13	1	Oil pipe spring
16	147.106.14	1	Full bump spring
17	080.010.00	1	Full bump spring cup
18	190.020.13	2	Engine mount bolt
19	185.011.00	1	Lower engine mount nut
20	174.029.99	1	Engine mount bracket
21	190.040.13	1	Lower engine mount bolt
22	185.012.00	2	Engine mount fixing nut
23	310.579.13	1	Bracket electrical devices
24	147.109.13	1	Main stand spring
25	184.011.00	1	Split pin

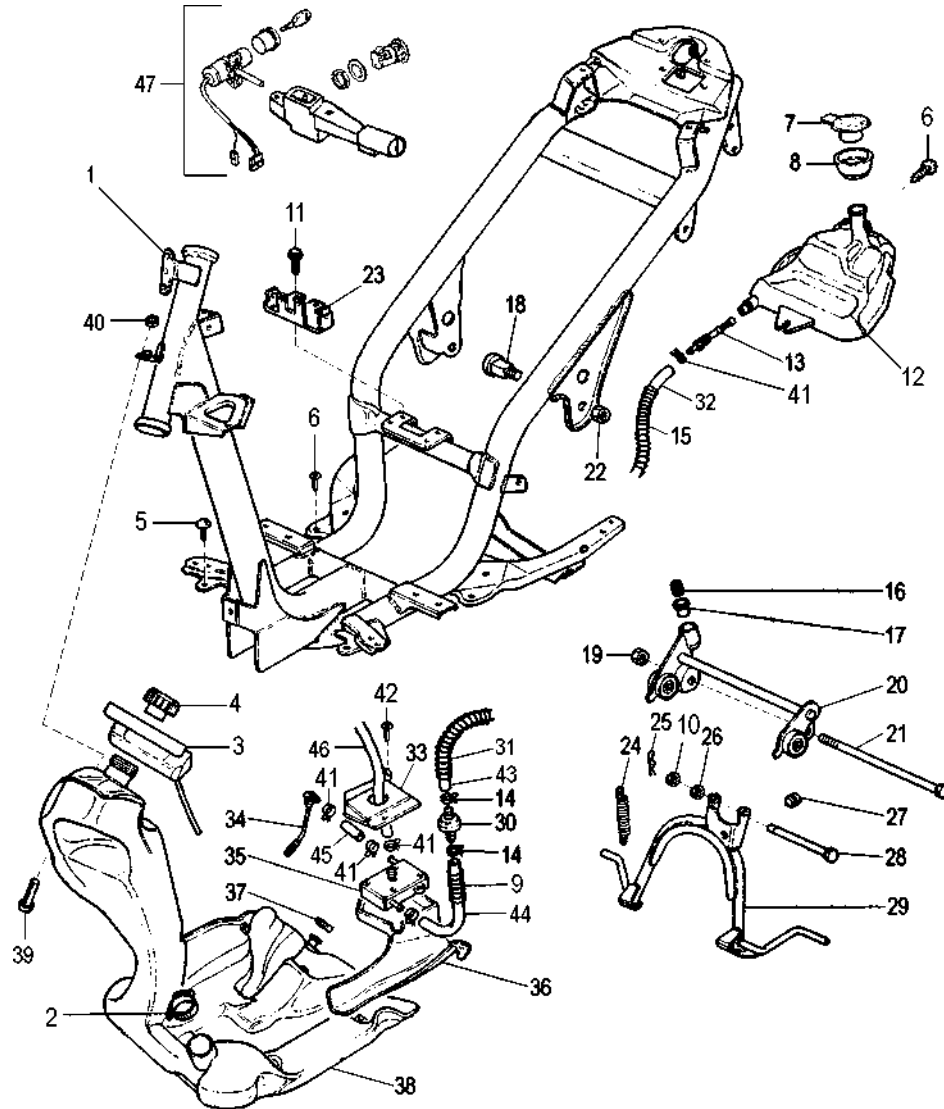
Telaio e serbatoio
Tank & frame

Nr.	Codice	Q.tà	Descrizione
26	071.140.03	1	Rondella in gomma
27	072.089.03	1	Gommino cavalletto
28	150.177.15	1	Perno cavalletto
29	158.048.99	1	Cavalletto centrale completo
30	094.011.00	1	Valvola benzina
31	147.107.13	1	Molla protezione tubo
32	180.003.59	1	Tubo olio
33	071.347.07	1	Coperchio scatola pompa benzina
34	093.063.00	1	Pescaggio benzina
35	093.057.00	1	Pompa benzina
36	071.340.03	1	Scatola pompa benzina
37	167.046.00	1	Fascetta pescaggio benzina
38	161.049.00	1	Serbatoio benzina
39	184.060.15	1	Vite
40	184.054.14	1	Dado
41	167.014.13	4	Fascetta per tubo
42	184.067.13	2	Vite fissaggio coperchio pompa
43	180.025.50	1	Tubo valvola - carburatore
44	180.010.59	1	Tubo pompa - valvola
45	180.010.57	1	Tubo pompa - pescaggio benzina
46	180.003.57	1	Tubo pompa - depressore
47	090.051.00	1	Kit serrature

Nr.	Code	Q.ty	Description
26	071.140.03	1	Main stand washer
27	072.089.03	1	Main stand bump stop
28	150.177.15	1	Main stand pivot pin
29	158.048.99	1	Main stand assy
30	094.011.00	1	Fuel valve
31	147.107.13	1	Fuel pipe spring
32	180.003.59	1	Oil pipe
33	071.347.07	1	Fuel pump cover
34	093.063.00	1	Fuel outlet
35	093.057.00	1	Fuel pump
36	071.340.03	1	Fuel pump box
37	167.046.00	1	Clamp
38	161.049.00	1	Fuel tank
39	184.060.15	1	Screw
40	184.054.14	1	Nut
41	167.014.13	4	Pipe clamp
42	184.067.13	2	Fuel pump cover fixing screw
43	180.025.50	1	Pipe (fuel valve - carburettor)
44	180.010.59	1	Pipe (fuel pump - fuel valve)
45	180.010.57	1	Pipe (fuel pump - fuel outlet)
46	180.003.57	1	Pipe (fuel pump - depressor)
47	090.051.00	1	Lock set

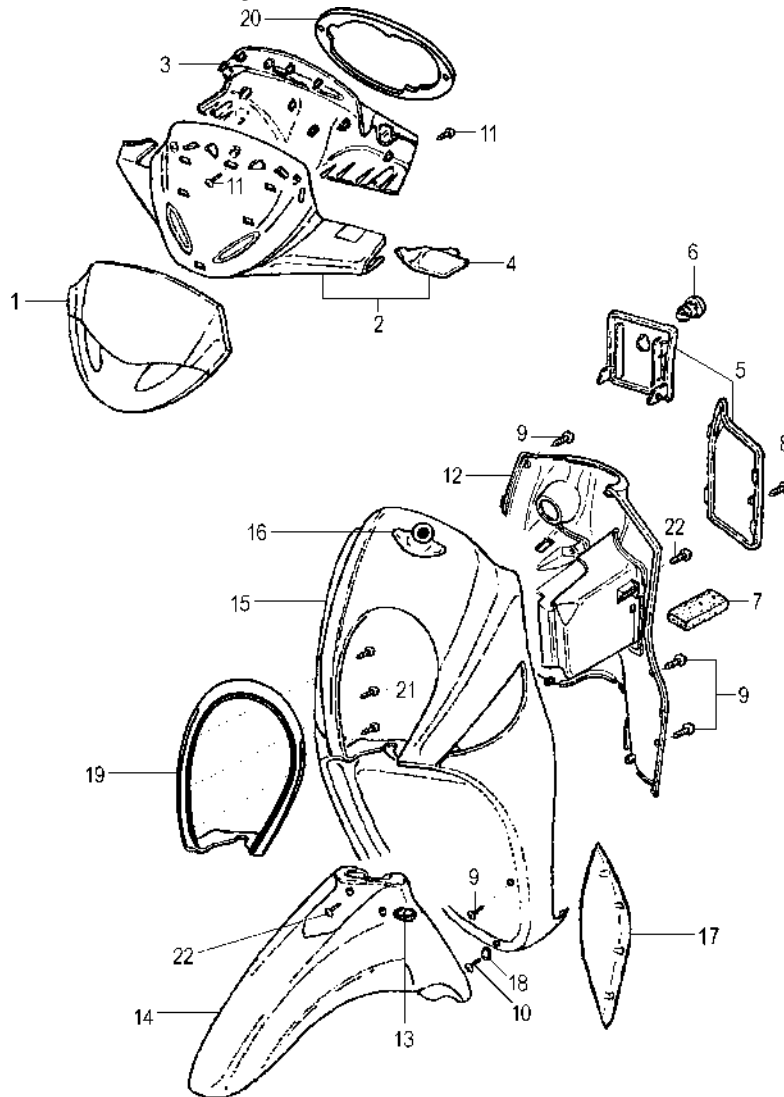
Carrozzeria anteriore
Front body

Nr.	Codice	Q.tà	Descrizione
1	071.301. --	1	Coprimanubrio anteriore *
2	071.304. --	1	Coprimanubrio centrale *
3	071.300. --	1	Coprimanubrio posteriore *
4	071.338.07	1	Coperchio pompa sx
5	071.613. --	1	Kit sportellini benzina - batteria *
6	090.024.00	1	Serratura sportello benzina
7	072.195.00	1	Tampone batteria
8	184.093.00	1	Vite autofilettante
9	184.041.15	8	Vite truciolare scudo paragambe
10	184.088.13	2	Vite scudo inferiore
11	184.067.13	11	Vite truciolare manubrio
12	065.060. --	1	Paragambe *
13	080.009.00	2	Passacavo
14	055.052. --	1	Parafango anteriore *
15	066.156. --	1	Scudo anteriore *
16	181.387.00	1	Etichetta adesiva
17	071.434. --	1	Cp. protezioni scudo *
18	184.265.13	2	Rondella scudo inferiore
19	071.591.16	1	Cornice faro
20	071.592.16	1	Cornice cruscotto
21	184.072.00	6	Vite cornice faro
22	184.254.15	5	Vite
--	090.051.00	1	Kit serrature
--	181.397. --	1	Sr. marche CIAK MASTER 50*

Nr.	Code	Q.ty	Description
1	071.301. --	1	Handlebar cover (front) *
2	071.304. --	1	Handlebar cover (middle) *
3	071.300. --	1	Handlebar cover (rear) *
4	071.338.07	1	Cover master cylinder
5	071.613. --	1	Inspection lid set *
6	090.024.00	1	Box lock
7	072.195.00	1	Pad
8	194.093.00	1	Screw
9	184.041.15	8	Screw
10	184.088.13	2	Screw
11	184.067.13	11	Handlebar cover screw
12	065.060. --	1	Front inner shield*
13	080.009.00	2	Fairlead
14	055.052. --	1	Front mudguard *
15	066.156. --	1	Front shield *
16	181.387.00	1	Front shield label
17	071.434. --	1	Protection shield *
18	184.265.13	2	Washer
19	071.591.16	1	Headlight rim
20	071.592.16	1	Dashboard rim
21	184.072.00	6	Screw
22	184.254.15	5	Screw
--	090.051.00	1	Lock set
--	181.397. --	1	CIAK MASTER 50 label set *

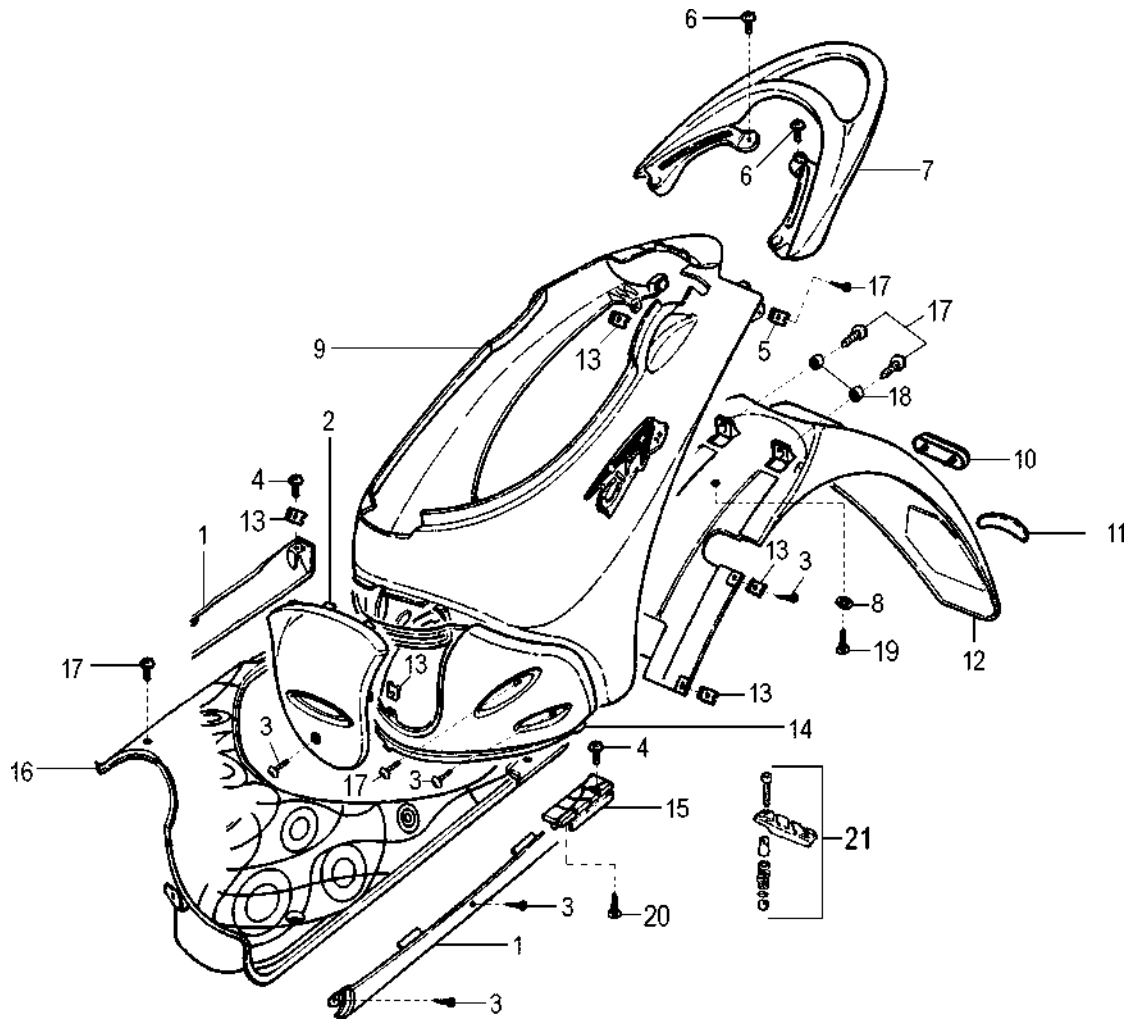
Carrozzeria posteriore
Rear body

Nr.	Codice	Q.tà	Descrizione
1	063.177. --	1	Laterali dx / sx in coppia *
2	071.299.07	1	Coperchio carena
3	184.093.00	15	Vite autofilettante
4	184.073.00	2	Vite truciolare scudo paragambe
5	184.206.00	2	Clips vite autofilettante
6	184.255.15	4	Vite maniglia
7	063.171.87	1	Maniglione
8	184.051.13	1	Rondella
9	063.153. --	1	Carena posteriore *
10	071.322.00	1	Catadiottro rosso
11	181.084.00	1	Etichetta in resina
12	063.152. --	1	Codino paraspruzzi *
13	184.007.00	13	Clips viti autofilettante
14	071.307.07	1	Unione carena
15	071.361.00	1	Tappi sede staffe dx / sx in cp.
16	064.021.03	1	Pedana poggia piedi
17	184.254.15	8	Vite
18	150.148.14	2	Rondella parafango
19	184.171.15	1	Vite parafango posteriore
20	184.041.15	2	Vite pedalini passeggero
21	084.038.00	1	Kit staffe passeggero
--	181.397. --	1	Sr. marche CIAK MASTER 50*

Nr.	Code	Q.ty	Description
1	063.177. --	1	Side bumpers set *
2	071.299.07	1	Inspection cover
3	184.093.00	15	Screw
4	184.073.00	2	Screw
5	184.206.00	2	Fixing clip
6	184.255.15	4	Screw
7	063.171.87	1	Handle pillion rider
8	184.051.13	1	Washer
9	063.153. --	1	Rear fairing *
10	071.322.00	1	Red reflector
11	181.084.00	1	Rear fender label
12	063.152. --	1	Rear fender *
13	184.007.00	13	Fixing clip
14	071.307.07	1	Central protection
15	071.361.00	1	Foot board plug
16	064.021.03	1	Foot board panel
17	184.254.15	8	Screw
18	150.148.14	2	Washer
19	184.171.15	1	Screw
20	184.041.15	2	Screw
21	084.038.00	1	Footrest kit
--	181.397. --	1	CIAK MASTER 50 label set *

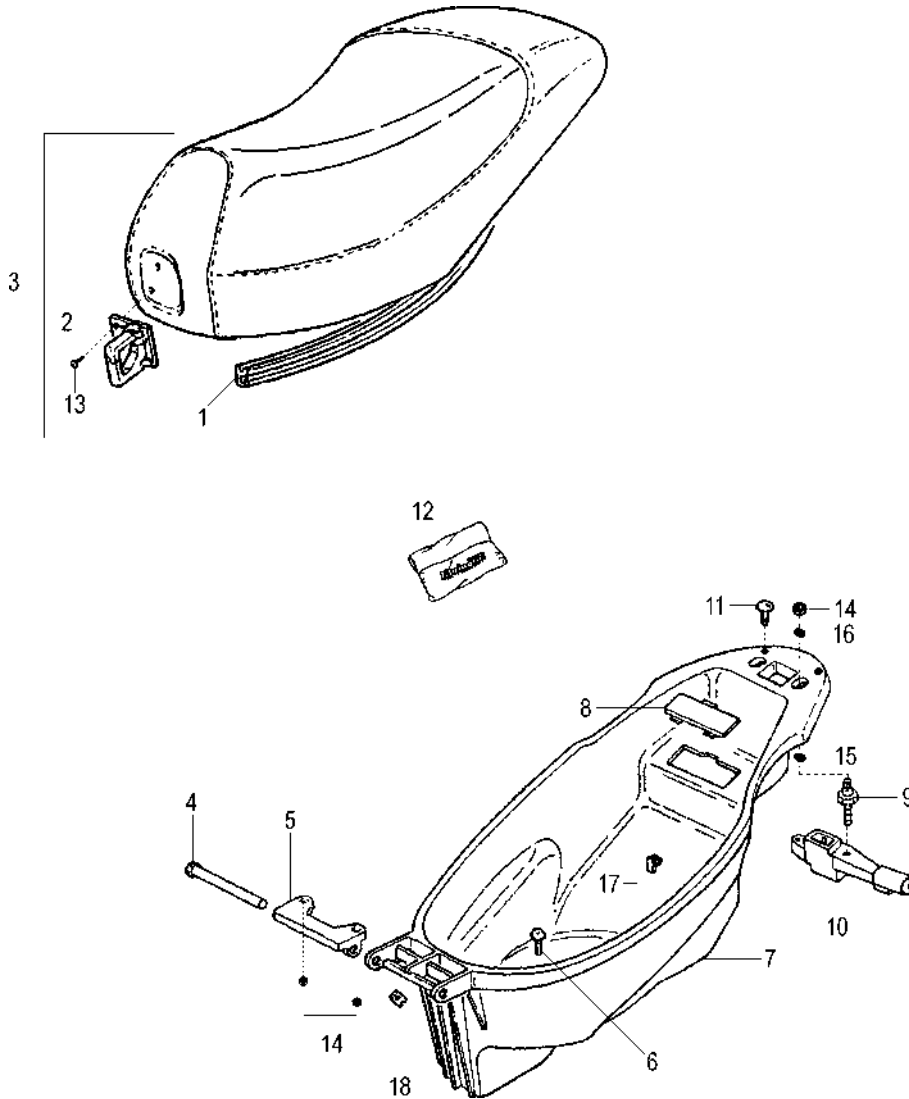
Gruppo sella e vano casco
Seat & helmet case

Nr.	Codice	Q.tà	Descrizione
1	072.061.03	1	Guarnizione sella
2	071.182.03	1	Gancio porta borsa
3	106.104.03	1	Sellone completo
4	150.174.13	1	Tubo fulcro sella
5	188.040.99	1	Supporto sella
6	190.022.00	2	Vite fissaggio vano portacasco
7	065.061.03	1	Vano portacasco
8	071.145.03	1	Coperchio numeri
9	190.023.00	2	Vite fissaggio serratura
10	090.047.00	1	Serratura sella
11	071.152.03	2	Gommino paracolpi sella
12	086.009.13	1	Trousse attrezzi
13	184.041.15	2	Vite gancio sella
14	184.054.14	4	Dado sella - vano casco
15	184.053.13	2	Rondella
16	184.265.13	2	Rondella
17	167.070.00	1	Fascetta vano casco
18	184.007.00	1	Clip vite autofilettante
--	090.051.00	1	Kit serrature

Nr.	Code	Q.ty	Description
1	072.061.03	1	Seat base seal
2	071.182.03	1	Bag handle
3	106.104.03	1	Seat
4	150.174.13	1	Seat hinge pin
5	188.040.99	1	Seat hinge bracket
6	190.022.00	2	Fixing bolt
7	065.061.03	1	Helmet case
8	071.145.03	1	VIN numbers inspection cover
9	190.023.00	2	Fixing screw
10	090.047.00	1	Seat lock
11	071.152.03	2	Rubber grommet
12	086.009.13	1	Tool set
13	184.041.15	2	Screw
14	184.054.14	4	Nut
15	184.053.13	2	Washer
16	184.265.13	2	Washer
17	167.070.00	1	Clamp
18	184.007.00	1	Fixing clip
--	090.051.00	1	Lock set

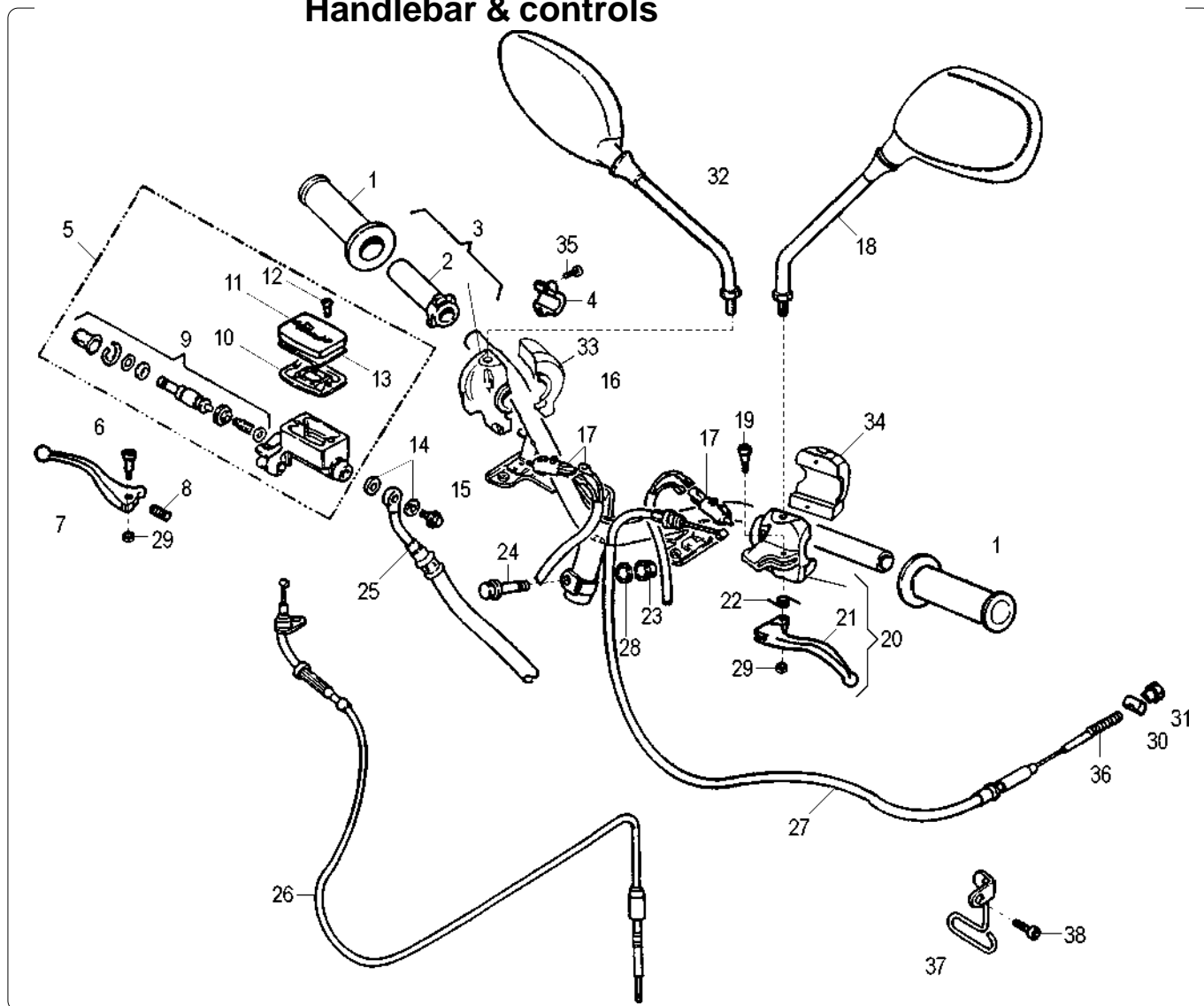
Manubrio e comandi
Handlebar & controls

Nr.	Codice	Q.tà	Descrizione
26	034.088.03	1	Trasmissione gas
27	048.033.03	1	Trasmissione freno posteriore
28	184.094.13	1	Rondella
29	184.054.14	2	Dado leva freno
30	119.354.13	1	Barilotto
31	184.344.13	1	Vite regolazione freno
32	088.014.03	1	Specchio dx (optional Italia)
33	020.051.00	1	Commutatore dx
34	020.052.00	1	Commutatore sx
35	184.247.00	2	Vite attacco pompa freno
36	147.086.13	1	Molla freno posteriore
37	147.123.13	1	Guida cavo freno posteriore
38	184.088.13	1	Vite

Nr.	Code	Q.ty	Description
26	034.088.03	1	Throttle cable
27	048.033.03	1	Rear brake cable
28	184.094.13	1	Washer
29	184.054.14	1	Nut
30	119.354.13	1	Rear brake cable nipple
31	184.344.13	1	Rear brake adjusting screw
32	088.014.03	1	R/h mirror (optional Italia)
33	020.051.00	1	R/h switch
34	020.052.00	1	L/h switch
35	184.247.00	2	Screw
36	147.086.13	1	Rear brake cable spring
37	147.123.13	1	Rear brake cable guide
38	184.088.13	1	Screw

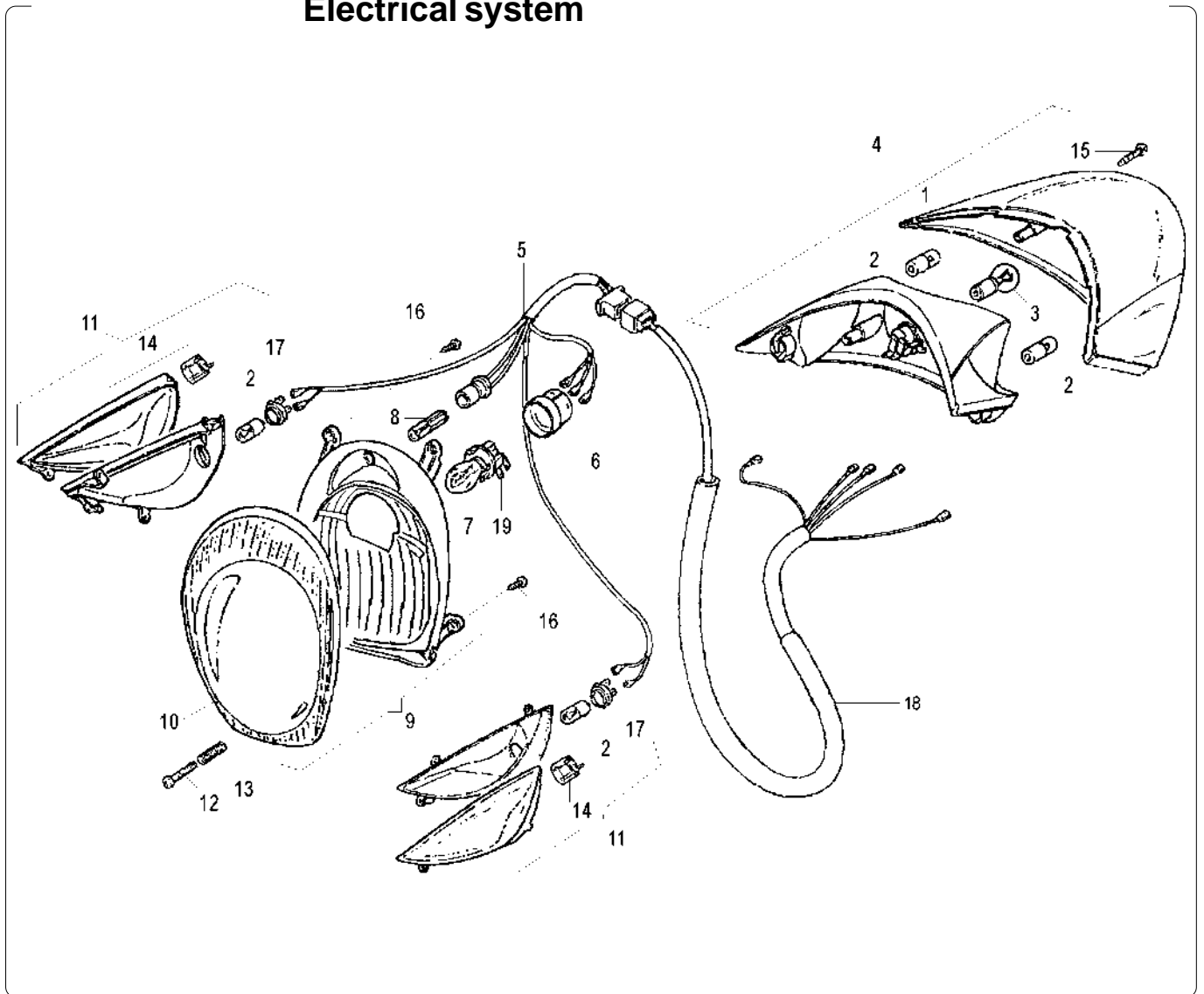
Impianto elettrico
Electrical system

Nr.	Codice	Q.tà	Descrizione
1	016.061.00	1	Vetro fanalino posteriore
2	022.017.00	4	Lampadina 12 V - 10 W
3	022.048.00	1	Lampadina 12 V - 5 / 21 W
4	016.057.00	1	Fanalino posteriore
5	017.244.00	1	Cablaggio faro anteriore
6	072.104.00	1	Cappuccio faro anteriore
7	022.061.00	1	Lampadina 12 V - 35 / 35 W
8	022.050.00	1	Lampadina 12 V - 5 W
9	015.041.00	1	Faro anteriore
10	063.176.00	1	Trasparente faro anteriore
11	019.055.00	1	Indicatori anteriori sx / dx in cp.
12	190.004.00	1	Vite regolazione faro anteriore
13	147.072.14	1	Molla regolazione faro anteriore
14	019.061.00	2	Vetro indicatori anteriori sx / dx
15	184.200.13	2	Vite fanalino posteriore
16	184.067.13	10	Vite fissaggio faro - frecce anteriori
17	023.023.00	2	Portalampada frecce anteriori
18	017.410.00	1	Cablaggio centrale
19	023.018.00	1	Portalammoda faro

Nr.	Code	Q.ty	Description
1	016.061.00	1	Rear light assembly lens
2	022.017.00	4	12 V - 10 W bulb
3	022.048.00	1	12 V - 5-21 W bulb
4	016.057.00	1	Rear light assembly
5	017.244.00	1	Head lamp wiring harness
6	072.104.00	1	Headlamp rubber cap
7	022.061.00	1	12 V - 35 / 35 W bulb
8	022.050.00	1	12 V - 5 W bulb
9	015.041.00	1	Head light assy
10	063.176.00	1	Head light glass
11	019.055.00	1	L/h+r/h front indicators
12	190.004.00	1	Head lamp adjusting screw
13	147.072.14	1	Head lamp adjusting spring
14	019.061.00	2	L/h-r/h front indicators lens
15	184.200.13	2	Rear light screw
16	184.067.13	10	Screw
17	023.023.00	2	L/h-r/h front indicators socket
18	017.410.00	1	Main wiring harness
19	023.018.00	1	Headlight socket

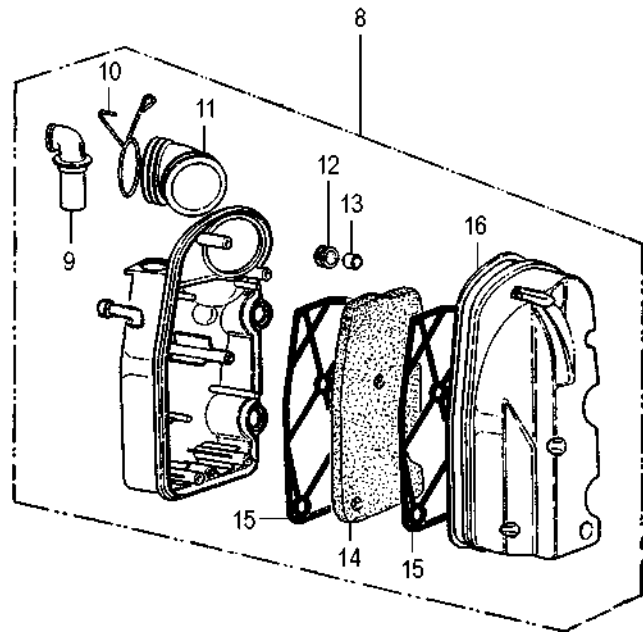
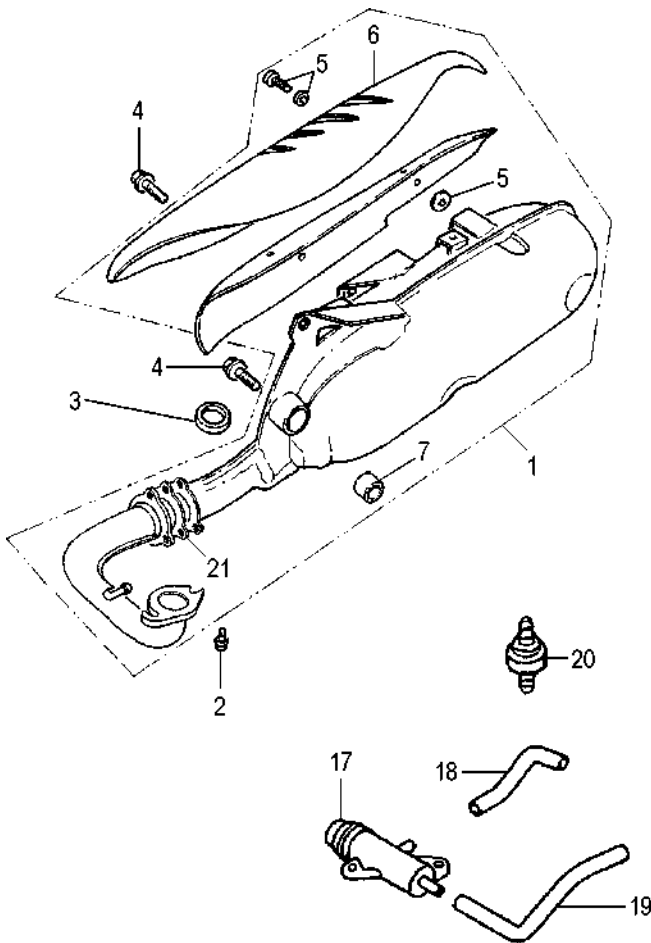
Gruppo scarico e aspirazione
Exhaust assembly

Nr.	Codice	Q.tà	Descrizione
1	165.184.99	1	Marmitta catalitica completa
2	184.006.00	2	Vite fissaggio marmitta - cilindro
3	072.053.00	1	Guarnizione
4	184.038.13	2	Viti fissaggio marmitta - carter
5	150.211.00	3	Kit fissaggio griglia
6	071.344.00	1	Griglia esterna con isolante
7	075.024.00	1	Silentblock marmitta
8	066.092.03	1	Cassetta filtro completa
9	076.012.00	1	Manicotto aspirazione piccolo
10	147.082.13	1	Molla manicotto aspirazione
11	076.015.00	1	Manicotto aspirazione grande
12	080.002.07	2	Passacavo
13	150.043.00	2	Distanziale
14	066.091.00	1	Filtro aspirazione
15	071.337.03	2	Griglia per filtro
16	072.078.00	1	Guarnizione cassetta
17	094.023.00	1	Valvola aria AIS
18	077.046.00	1	Tubo valvola - marmitta
19	180.051.00	1	Tubo valvola - filtro
20	094.026.00	1	Filtro
21	072.158.00	1	Guarnizione

Nr.	Code	Q.ty	Description
1	165.184.99	1	Kat-exhaust assy
2	184.006.00	2	Exhaust fixing screw
3	072.053.00	1	Exhaust gasket
4	184.038.13	2	Exhaust fixing screw
5	150.211.00	3	Screws set
6	071.344.00	1	Heat shield
7	075.024.00	1	Exhaust silentblock
8	066.092.03	1	Air box complete
9	076.012.00	1	Airbox intake sleeve
10	147.082.13	1	Air box hose spring clip
11	076.015.00	1	Air box/carb. sleeve
12	080.002.07	2	Grommet
13	150.043.00	2	Spacer
14	066.091.00	1	Air filter
15	071.337.03	2	Holder filter
16	072.078.00	1	Gasket air box cover
17	094.023.00	1	One-way air valve AIS
18	077.046.00	1	Hose (valve - exhaust)
19	180.051.00	1	Hose (valve - filter)
20	094.026.00	1	Filter
21	072.158.00	1	Gasket

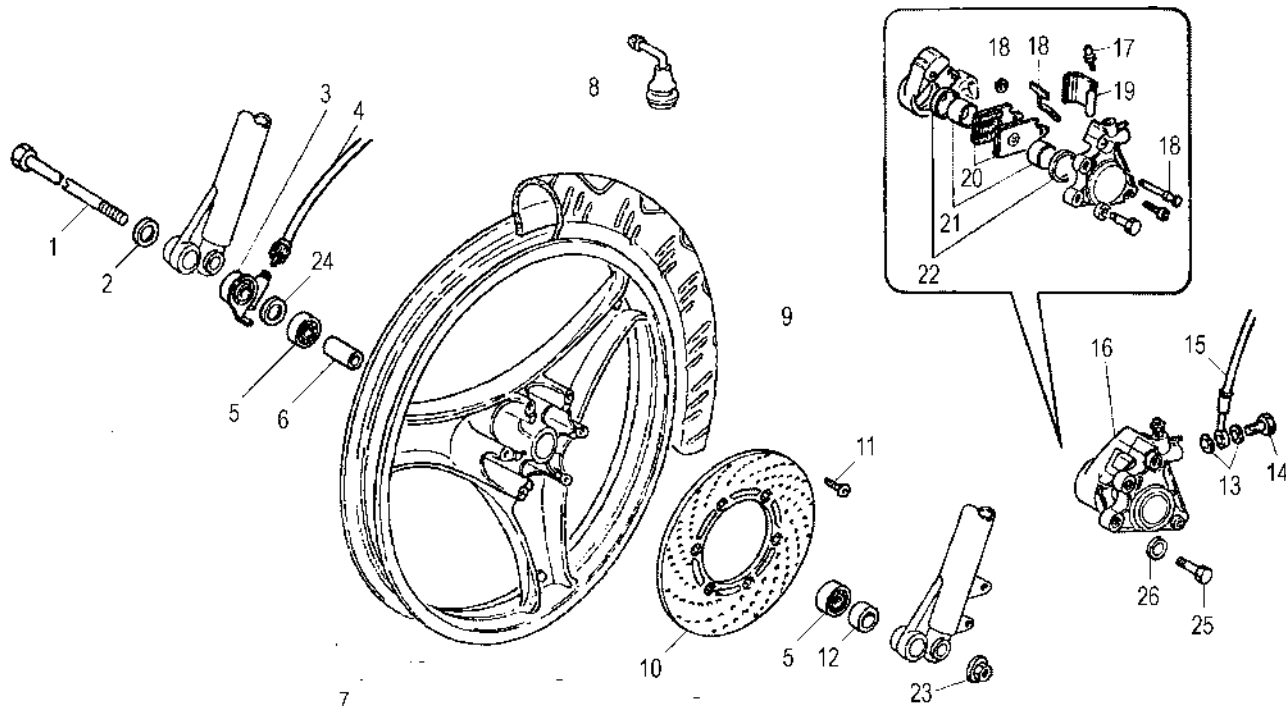

Nr.	Codice	Q.tà	Descrizione
1	119.471.00	1	Perno ruota
2	184.111.13	1	Rondella
3	178.142.00	1	Rinvio contakm
4	178.144.00	1	Trasmissione contakm
5	119.411.00	2	Cuscinetto
6	119.472.00	1	Distanziale
7	109.067.08	1	Ruota anteriore
8	094.008.00	1	Valvola tubeless
9	050.054.00	1	Copertura 2.75 / 80 x 16 " - tubeless
10	119.466.00	1	Disco freno anteriore
11	119.422.00	6	Vite disco freno
12	119.423.00	1	Distanziale
13	190.006.00	2	Rasamenti
14	150.024.14	1	Vite trasmissione idraulica
15	033.038.00	1	Trasmissione idraulica
16	031.019.08	1	Pinza freno anteriore
17	119.436.00	1	Valvola di sfiato
18	119.457.00	1	Kit perno + piastra + seeger
19	119.434.00	1	Cuffia protezione pompa
20	119.502.00	1	Pastiglie freno anteriori
21	119.435.00	1	Pistoncini pompa freno
22	119.440.00	1	Serie anelli di tenuta
23	185.011.00	1	Dado
24	190.067.00	1	Rasamento rinvio contakm
25	184.031.13	2	Vite fissaggio pinza freno anteriore
26	184.053.13	2	Rondella

Nr.	Code	Q.ty	Description
1	119.471.00	1	Front wheel spindle
2	184.111.13	1	Washer
3	178.142.00	1	Speedo drive
4	178.144.00	1	Speedo cable
5	119.411.00	2	Bearing
6	119.472.00	1	Spacer
7	109.067.08	1	Front wheel
8	094.008.00	1	Front air valve
9	050.054.00	1	Tyre tubeless 2.75 / 80 x 16 "
10	119.466.00	1	Front brake disc
11	119.422.00	6	Brake disc mounting screw
12	119.423.00	1	Spacer
13	190.006.00	2	Copper banjo washer
14	150.024.14	1	Banjo bolt
15	033.038.00	1	Front brake hose
16	031.019.08	1	Front brake caliper
17	119.436.00	1	Bleeding overhaul
18	119.457.00	1	Caliper kit
19	119.434.00	1	Brake pad cover
20	119.502.00	1	Brake pads
21	119.435.00	1	Front brake piston set
22	119.440.00	1	Seal ring set
23	185.011.00	1	Front wheel nut
24	190.067.00	1	Washer
25	184.031.13	2	Front brake caliper screw
26	184.053.13	2	Washer

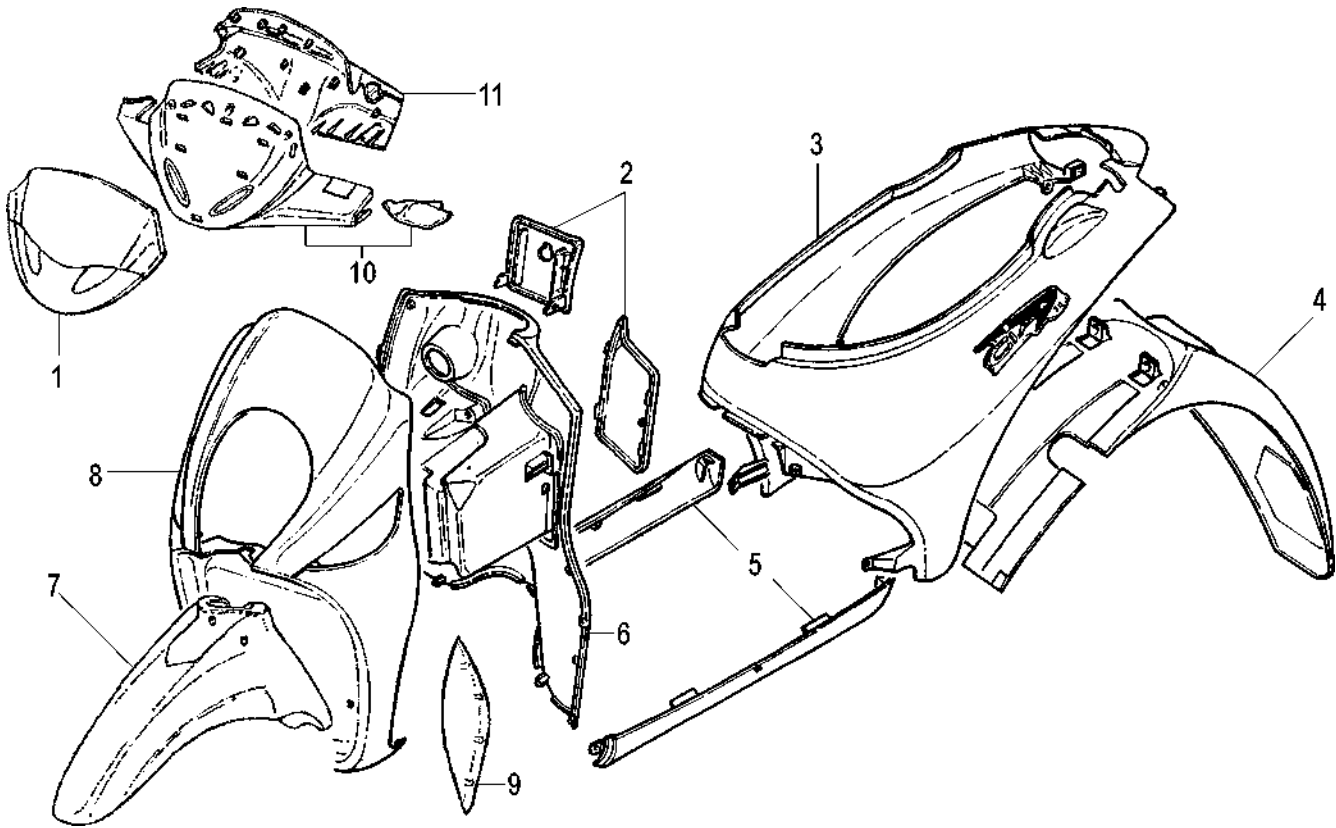
**Colori moto
Colour table**

TABELLA COLORI - COLOUR CODES
Colori - Colours

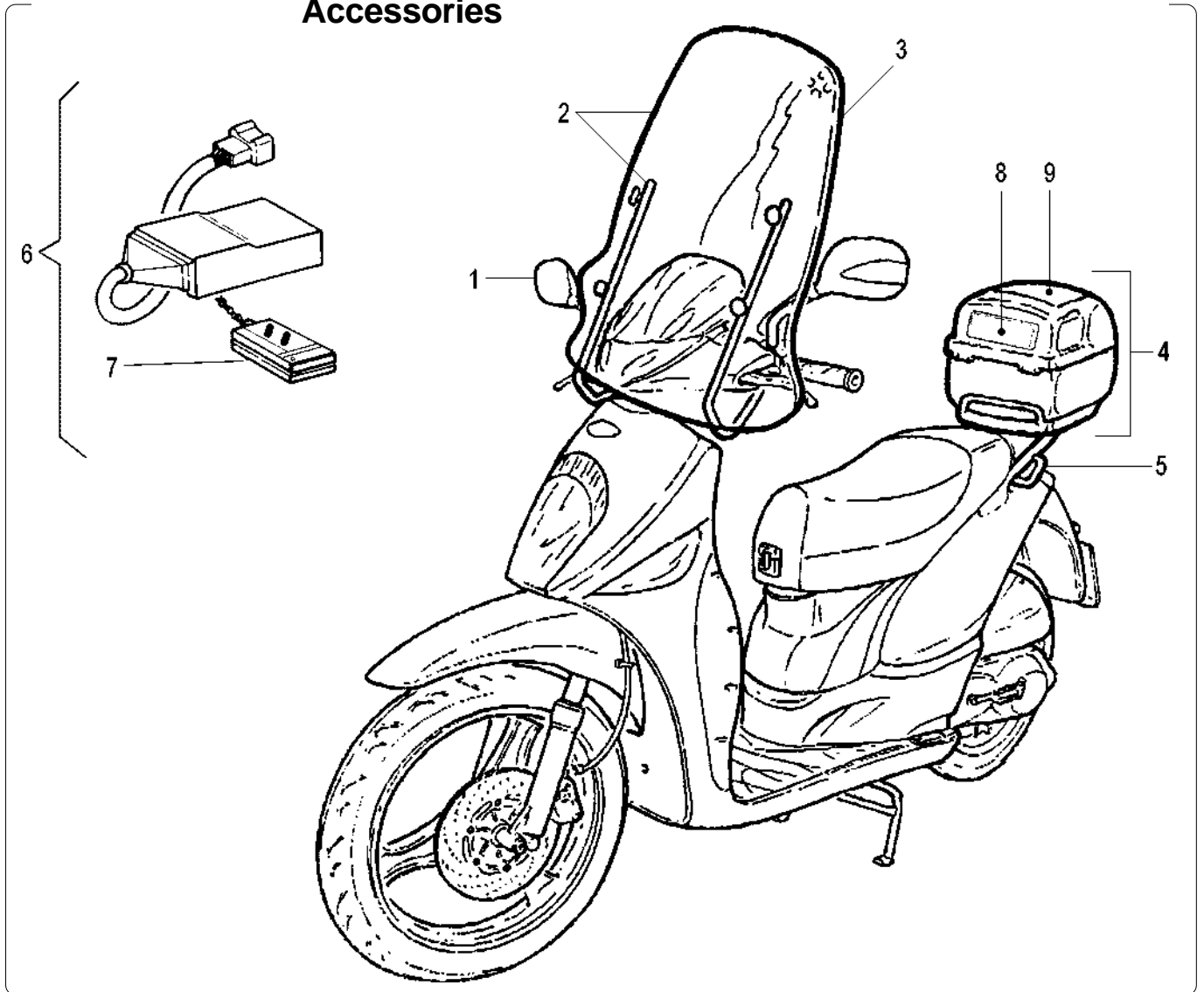
N° Nr.	Codice Code	84 Blu Royal Royal Blue	87 Argento Lucido Bright Silver	94 Blu Notte Dark Blue				
1	071.301.	84	87	94				
2	071.613.	84	87	94				
3	063.153.	84	87	94				
4	063.152.	84	87	94				
5	063.177.	84	87	94				
6	065.060.	84	87	94				
7	055.052.	84	87	94				
8	066.156.	84	87	94				
9	071.434.	84	87	94				
10	071.304.	84	87	94				
11	071.300.	84	87	94				
--	181.397.	01	00	01				

**Accessori
Accessories**

Nr.	Codice	Q.tà	Descrizione	Nr.	Code	Q.ty	Description
1	088.014.03	1	Specchio dx (di serie mercato estero)	1	088.014.03	1	R/h mirror (originally fitted)
2	063.174.00	1	Parabrezza completo	2	063.174.00	1	Windscreen
3	063.175.00	1	Lastra parabrezza	3	063.175.00	1	Windscreen glass
4	065.170. --	1	Baulone porta casco (26 litri)	4	065.170. --	1	Top case (26 ltr.)
5	173.065.00	1	Porta pacco	5	173.065.00	1	Rear carrier
6	018.078.00	1	Antifurto + cablaggio	6	018.078.00	1	Alarm complete
7	018.079.00	1	Radiocomando antifurto	7	018.079.00	1	Remote control
8	065.084.03	1	Schienale bauletto	8	065.084.03	1	Top case cushion
9	065.122. --	1	Cover bauletto	9	065.122. --	1	Top case cover
--	065.027.00	1	Coprimoto scooter standard	--	065.027.00	1	Scooter canvas cover
--	065.077.00	1	Coprimoto scooter con accessori	--	065.077.00	1	Accessoried scooter canvas cover

Tabella colori baulone - Top case colour codes

N° Nr.	Codice Code	Nero Black	Argento Silver	Blu Notte Dark Blue	Blu Royal Royal Blue	
4	065.170.	03	87	94	74	
9	065.122.	03	87	94	74	

Motore 31 MY
31 MY engine parts

Nr.	Codice	Q.tà	Descrizione
15	715.102.00	1	Carburatore DELL'ORTO PHVA 12 - PS / R 6330
19	771.161.00	1	Cilindro completo + pistone
48	024.044.00	1	Motorino avviamento
62	771.157.00	1	Pistone completo Ø 40
77	777.019.00	1	Testa
80	780.003.00	1	Ventola
82	782.026.00	1	Volano magnete
111	711.008.00	1	Candela
172	717.010.00	1	Cinghia di trasmissione
211	721.067.00	1	Convogliatore ventola
212	721.076.00	1	Coperchio messa in moto completo
213	721.056.00	1	Coperchio trasmissione
215	721.054.00	1	Cuffia convogliatore cilindro
381	771.205.00	1	Imbiellaggio + gabbia
382	771.118.00	1	Biella completa
601	760.074.00	1	Puleggia anteriore fissa
604	760.075.00	1	Puleggia anteriore mobile + boccola
606	760.045.00	1	Collettore aspirazione
641	764.011.00	1	Pompa olio completa
681	771.142.00	1	Serie segmenti Ø 40
701	770.025.00	1	Coppia carter
912	701.044.00	1	Albero messa in moto
914	701.061.00	1	Albero uscita moto completo Z = 45
916	701.046.00	1	Albero trasmissione Z = 13
2449	724.051.00	2	Gommino supporto convogliatore cilindro
2479	724.075.00	1	Gommino silentblock carter
2485	724.052.00	1	Raccordo plastica sfiato olio
2492	724.048.00	1	Tappo alimentazione olio
2493	724.049.00	3	Tassello di traino
2496	724.074.00	1	Tubo entrata olio
2601	726.027.00	1	Campana frizione completa
2626	726.028.00	1	Puleggia secondaria fissa completa
2627	726.030.00	1	Puleggia secondaria mobile completa
2642	726.020.00	1	Cappello porta tasselli
2664	726.021.00	1	Piastrina ritegno paraolio
2665	726.022.00	1	Piastrina ingranaggio doppio intermedio E/S
2667	726.023.00	1	Piastrina traino puleggia anteriore fissa
2688	726.026.00	1	Scodellino dentato messa in moto
2689	726.029.00	1	Scodellino portamolla variatore
3520	735.028.00	1	Frizione centrifuga completa
4040	740.159.00	1	Ingranaggio doppio intermedio completo Z = 11 / 52
4041	740.121.00	1	Ingranaggio doppio intermedio E/S + boccola
4043	740.122.00	1	Corona avviamento elettrico Z = 71

Nr.	Code	Q.ty	Description
15	715.102.00	1	Carburettor DELL'ORTO PHVA 12 - PS / R 6330
19	771.161.00	1	Cylinder assy
48	024.044.00	1	Starter motor
62	771.157.00	1	Piston assy Ø 40
77	777.019.00	1	Cylinder head
80	780.003.00	1	Fan
82	782.026.00	1	Magneto flywheel assy
111	711.008.00	1	Spark plug
172	717.010.00	1	V-belt
211	721.067.00	1	Air shroud (outer)
212	721.076.00	1	Case cover
213	721.056.00	1	Gear cover
215	721.054.00	1	Air shroud (inner)
381	771.205.00	1	Crankshaft
382	771.118.00	1	Connecting rod
601	760.074.00	1	Primary fixed pulley
604	760.075.00	1	Primary pulley
606	760.045.00	1	Intake manifold
641	764.011.00	1	Oil pump assy
681	771.142.00	1	Piston ring set Ø 40
701	770.025.00	1	Crankcase assy
912	701.044.00	1	Kick start shaft
914	701.061.00	1	Drive shaft assy Z = 45
916	701.046.00	1	Gear shaft Z = 13
2449	724.051.00	2	Cylinder cover grommet
2479	724.075.00	1	Rubber
2485	724.052.00	1	Oil breather pipe
2492	724.048.00	1	Oil plug
2493	724.049.00	3	Dowels
2496	724.074.00	1	Oil pipe
2601	726.027.00	1	Clutch housing
2626	726.028.00	1	Secondary fixed pulley
2627	726.030.00	1	Secondary pulley
2642	726.020.00	1	Dowelholder cap
2664	726.021.00	1	Plate
2665	726.022.00	1	Idle gear plate
2667	726.023.00	1	Drive pulley lock washer
2688	726.026.00	1	Drive plate
2689	726.029.00	1	Spring holder
3520	735.028.00	1	Clutch assy
4040	740.159.00	1	Idle gear assy Z = 11 / 52
4041	740.121.00	1	Idle gear assy E/S
4043	740.122.00	1	Kick star gear Z = 71

CIAK MASTER 50 - 2T Euro 2-2004

Motore 31 MY

31 MY engine parts

Nr.	Codice	Q.tà	Descrizione
4048	740.123.00	1	Ingranaggio conduttore pompa olio
4066	740.124.00	1	Ingranaggio scorrevole messa in moto
4085	740.125.00	1	Ruota libera completa
4618	746.048.00	1	Molla puleggia secondaria mobile
4626	746.044.00	1	Molla scorrevole messa in moto
4645	746.047.00	3	Molla richiamo ceppi frizione
4665	746.042.00	1	Molla ritorno leva messa in moto
4680	746.045.00	1	Molla a disco ingranaggio doppio intermedio
5104	751.063.00	1	Distanziale c/gola Ø 18 x 23 x 4.4
5105	751.041.00	1	Boccola albero messa in moto Ø 15 x 20 x 30
5108	751.042.00	1	Boccola flangiata corona E/S
5113	751.043.00	1	Gabbia KBK Ø 10 x 14 x 12,5
5127	751.045.00	1	Boccola puleggia anteriore mobile
5148	104.028.00	1	Cuscinetto Ø 17 x 40 x 12 (6203)
5150	751.046.00	1	Cuscinetto Ø 17 x 40 x 12 (6203 - 2RS1)
5151	751.047.00	2	Cuscinetto Ø 10 x 30 x 9 (6200 - C3)
5179	751.072.00	2	Cuscinetto Ø 17 x 35 x 10 stagno (6003 - 2RS)
5305	753.135.00	2	Anello di tenuta OR Ø 36 x 1,5
5315	753.105.00	1	Anello di tenuta OR Ø 13.3 x 2.4
5320	753.129.00	1	Guarnizione base cilindro
5327	753.120.00	1	Guarnizione coperchio messa in moto
5328	753.121.00	1	Guarnizione coperchio trasmissione
5339	753.109.00	1	Guarnizione statore volano
5347	753.110.00	1	Guarnizione valvola lamelle
5350	753.111.00	1	Guarnizione testa
5359	753.112.00	1	Guarnizione vite scarico olio
5602	756.098.00	6	Massa centrifuga completa Ø 9.25
5615	756.029.00	2	Grano riferimento carter
5616	756.030.00	4	Grano riferimento coperchi
5628	756.074.00	1	Perno ceppi freno
5640	756.070.00	1	Perno Ø 8 x 32
5662	756.071.00	1	Rullo Ø 3 x 11.8
5668	756.082.00	2	Rullino di guida variatore
5670	756.073.00	1	Spinotto Ø 10 x 33
6015	760.046.00	1	Valvola lamelle completa
6050	094.023.00	1	Valvola aria AIS
9323	703.028.00	2	Anello fermo spinotto Ø 11.8
9353	703.005.00	1	Anello seeger albero Ø 15
9368	703.025.00	1	Anello seeger foro Ø 40
9375	703.026.00	2	Anello seeger albero Ø 19
15269	715.096.00	1	Raccordo tubo depressore
49004	749.148.00	1	Fascetta tubo pompa olio
49005	749.270.00	1	Fascetta antimanomissione flangia aspirazione

Nr.	Code	Q.ty	Description
4048	740.123.00	1	Pump drive gear
4066	740.124.00	1	Kick start pinion gear
4085	740.125.00	1	Free wheel assy
4618	746.048.00	1	Secondary pulley spring
4626	746.044.00	1	Kick start thrust spring
4645	746.047.00	3	Clutch pads spring
4665	746.042.00	1	Kick start return spring
4680	746.045.00	1	Idle gear spring
5104	751.063.00	1	Spacer Ø 18 x 23 x 4.4
5105	751.041.00	1	Kick start shaft bush Ø 15 x 20 x 30
5108	751.042.00	1	Bush
5113	751.043.00	1	Cage Ø 10 x 14 x 12,5
5127	751.045.00	1	Primary pulley bush
5148	104.028.00	1	Bearing Ø 17 x 40 x 12 (6203)
5150	751.046.00	1	Bearing Ø 17 x 40 x 12 (6203 - 2RS1)
5151	751.047.00	2	Bearing Ø 10 x 30 x 9 (6200 - C3)
5179	751.072.00	2	Bearing Ø 17 x 35 x 10 (6003 - 2RS)
5305	753.135.00	2	Oil seal OR Ø 36 x 1,5
5315	753.105.00	1	Oil seal OR Ø 13.3 x 2.4
5320	753.129.00	1	Cylinder base gasket
5327	753.120.00	1	Sidecase gasket
5328	753.121.00	1	Gear box gasket
5339	753.109.00	1	Stator gasket
5347	753.110.00	1	Reed valve gasket
5350	753.111.00	1	Head gasket
5359	753.112.00	1	Oil drain gasket
5602	756.098.00	6	Centrifugal roller Ø 9.25
5615	756.029.00	2	Crankcase locating dowel
5616	756.030.00	4	Gearbox locating dowel
5628	756.074.00	1	Pin
5640	756.070.00	1	Pin Ø 8 x 32
5662	756.071.00	1	Pin Ø 3 x 11.8
5668	756.082.00	2	Pin guide
5670	756.073.00	1	Pin Ø 10 x 33
6015	760.046.00	1	Reed valve assy
6050	094.023.00	1	One way air valve AIS
9323	703.028.00	2	Circlip Ø 11.8
9353	703.005.00	1	Kick start circlip Ø 15
9368	703.025.00	1	Wheel bearing circlip Ø 40
9375	703.026.00	2	Oil pump circlip Ø 19
15269	715.096.00	1	T pipe
49004	749.148.00	1	Clamp
49005	749.270.00	1	Antitampering clamp

CIAK MASTER 50 - 2T Euro 2-2004

Motore 31 MY

31 MY engine parts

Nr.	Codice	Q.tà	Descrizione
49015	749.107.00	1	Chiavetta volano magnete
49028	749.263.00	1	Fascetta tubo depressore
49040	749.210.00	1	Dado M 10 x 1.25 H = 13.5
49041	749.181.00	1	Dado M 10 x 1.25 H = 8
49047	749.203.00	1	Dado M 10 x 1,25 - (CH = 25) - H = 7
49055	749.219.00	1	Dado M 28 x 1 - (CH = 42) - H = 4
49057	749.183.00	4	Dado fissaggio testa M 7 x 1
49058	749.184.00	1	Dado M 10 x 1 - H = 5.8 - (CH = 24)
49070	749.186.00	1	Distanziale cuscinetto paraolio frizione
49077	749.264.00	1	Distanziale attacco carter + seeger
49084	749.188.00	4	Prigioniero fissaggio testa M 7 x 1 x 109
49097	749.205.00	1	Rondella bisellata Ø 10 x 21 x 2
49129	749.189.00	1	Rondella acciaio blu Ø 15,1 x 28 x 1
49148	749.222.00	1	Rondella acciaio blu Ø 13.2 x 20 x 1.3
49162	749.206.00	1	Rondella acciaio blu Ø 14 x 29 x 1
49221	749.190.00	1	Vite autofilettante convogliatore ventola
49237	749.095.00	2	Vite M 5 x 14
49243	749.036.00	2	Vite M 6 x 16
49244	749.037.00	8	Vite M 6 x 20
49245	749.068.00	9	Vite M 6 x 25
49247	749.039.00	10	Vite M 6 x 35
49249	749.142.00	1	Vite M 6 x 45
49255	749.176.00	3	Vite M 6 x 12
49285	749.191.00	1	Vite scarico olio M 8 x 1,25 x 15
49292	749.282.00	3	Vite antimanomissione
49352	749.192.00	1	Rondella conica scodellino messa in moto
49353	749.193.00	1	Rondella Ø 10,5 x 18 x 2
49354	749.194.00	2	Rondella Ø 8 x 16 x 2
49500	749.196.00	1	Vite M 6 x 20 + rondella (nera)
49508	749.201.00	3	Vite M 6 x 16 + rondelle
51101	751.066.00	2	Cuscinetto Ø 20 x 47 x 14 (6204 - TN9/C4)
51301	751.053.00	1	Gabbia Ø 57 x 61 x 10 (57RFN - 6110A)
53501	753.115.00	1	Paraolio Ø 20 x 30 / 34 x 5 / 6.1
53502	753.116.00	1	Paraolio Ø 19 x 42 x 9
53503	753.117.00	1	Paraolio Ø 17 x 28 x 5.5
53504	753.118.00	1	Paraolio Ø 22 x 32 x 6
53506	753.136.00	2	Paraolio Ø 34 x 39 x 3
--	740.143.00	1	Gruppo variatore con frizione
--	771.124.00	1	Serie paraoli
--	771.158.00	1	Pistone completo Ø 40.5 - 1° maggiorazione
--	771.143.01	1	Serie segmenti Ø 41 - 2° maggiorazione
--	142.128.03	1	Motore completo EURO 2 - 2004 (174.128)

Nr.	Code	Q.ty	Description
49015	749.107.00	1	Woodruff key
49028	749.263.00	1	Clamp
49040	749.210.00	1	Nut M 10 x 1.25 H = 13.5
49041	749.181.00	1	Nut M 10 x 1.25 H = 8
49047	749.203.00	1	Nut M 10 x 1,25 - (CH = 25) - H = 7
49055	749.219.00	1	Nut M 28 x 1 - (CH = 42) - H = 4
49057	749.183.00	4	Nut M 7 x 1
49058	749.184.00	1	Nut M 10 x 1 - H = 5.8 - (CH = 24)
49070	749.186.00	1	Spacer
49077	749.264.00	1	Spacer
49084	749.188.00	4	Cylinder head stud M 7 x 1 x 109
49097	749.205.00	1	Washer Ø 10 x 21 x 2
49129	749.189.00	1	Washer Ø 15,1 x 28 x 1
49148	749.222.00	1	Washer Ø 13.2 x 20 x 1.3
49162	749.206.00	1	Washer Ø 14 x 29 x 1
49221	749.190.00	1	Screw
49237	749.095.00	2	Screw M 5 x 14
49243	749.036.00	2	Screw M 6 x 16
49244	749.037.00	8	Screw M 6 x 20
49245	749.068.00	9	Screw M 6 x 25
49247	749.039.00	10	Screw M 6 x 35
49249	749.142.00	1	Screw M 6 x 45
49255	749.176.00	3	Screw M 6 x 12
49285	749.191.00	1	Oil drain screw M 8 x 1,25 x 15
49292	749.282.00	3	Antitampering screw
49352	749.192.00	1	Washer
49353	749.193.00	1	Washer Ø 10,5 x 18 x 2
49354	749.194.00	2	Washer Ø 8 x 16 x 2
49500	749.196.00	1	Screw M 6 x 20 (black)
49508	749.201.00	3	Screw M 6 x 16
51101	751.066.00	2	Bearing Ø 20 x 47 x 14 (6204 - TN9/C4)
51301	751.053.00	1	Cage Ø 57 x 61 x 10 (57RFN - 6110A)
53501	753.115.00	1	Oil seal Ø 20 x 30 / 34 x 5 / 6.1
53502	753.116.00	1	Oil seal Ø 19 x 42 x 9
53503	753.117.00	1	Oil seal Ø 17 x 28 x 5.5
53504	753.118.00	1	Oil seal Ø 22 x 32 x 6
53506	753.136.00	2	Oil seal Ø 34 x 39 x 3
--	740.143.00	1	Variable transmission clutch set
--	771.124.00	1	Oil seal set
--	771.158.00	1	1° oversized piston assy - Ø 40.5
--	771.143.01	1	2° oversized piston ring set Ø 41
--	142.128.03	1	Engine assy EURO 2 - 2004 (174.128)

CIAK MASTER 50 - 2T Euro 2-2004

Motore 31 MY

31 MY engine parts

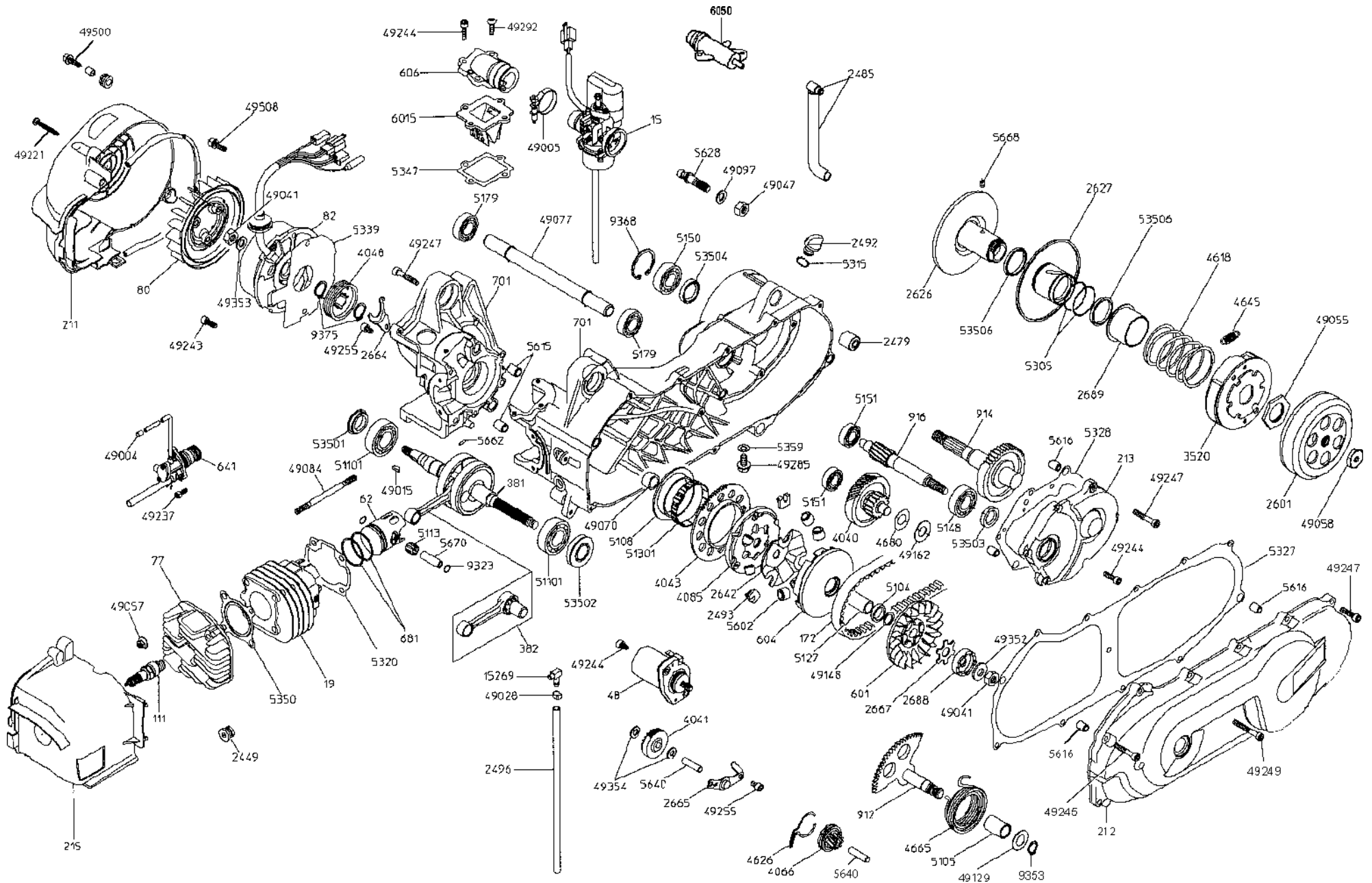

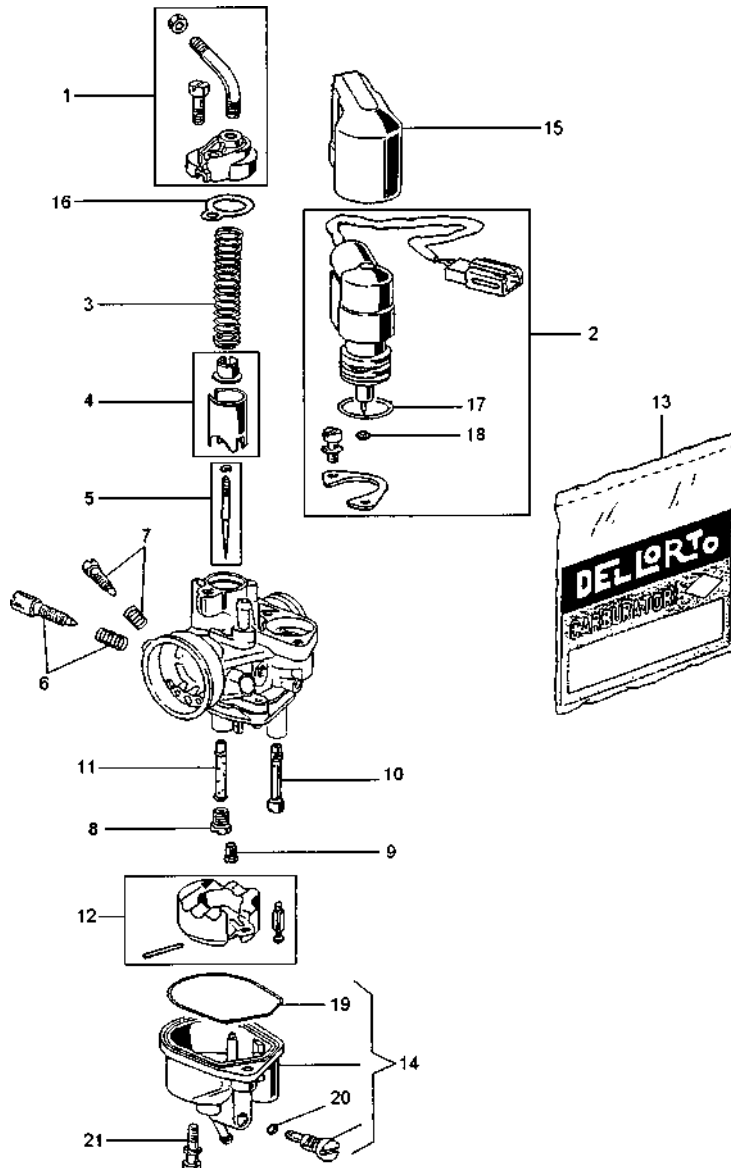
Carburatore
Carburettor

Nr.	Codice	Q.tà	Descrizione
01	623.072.00	1	Kit tubetto + coperchio valvola
02	623.075.00	1	Kit avviamento automatico
03	623.052.00	1	Molla richiamo valvola gas
04	623.069.00	1	Kit valvola gas
05	623.154.00	1	Kit spillo conico
06	623.094.00	1	Kit regolazione valvola gas
07	623.073.00	1	Kit regolazione aria minimo
08	623.132.00	1	Getto massimo Ø 60
09	623.045.00	1	Getto minimo Ø 38
10	623.090.00	1	Getto avviamento Ø 48
11	623.234.00	1	Polverizzatore GA 209
12	623.134.00	1	Kit spillo + galleggiante
13	623.066.00	1	Busta guarnizioni
14	623.065.00	1	Vaschetta
15	623.095.00	1	Cuffia termica
16			Vedi fig. 13
17			Vedi fig. 13
18			Vedi fig. 13
19			Vedi fig. 13
20			Vedi fig. 13
21	623.060.00	2	Vite fissaggio vaschetta
--	715.102.00	1	Carburatore completo Dell'Orto PHVA 12 - PS / R 6330

Nr.	Code	Q.ty	Description
01	623.072.00	1	Breather pipe / air intake kit
02	623.075.00	1	Starter, complete
03	623.052.00	1	Throttle valve spring
04	623.069.00	1	Throttle valve, complete
05	623.154.00	1	Needle valve
06	623.094.00	1	Throttle valve adj. screw
07	623.073.00	1	Klding mix adjusting screw
08	623.132.00	1	Max jet Ø 60
09	623.045.00	1	Idle jet Ø 38
10	623.090.00	1	Starting jet Ø 48
11	623.234.00	1	Spray nozzle GA 209
12	623.134.00	1	Float assy
13	623.066.00	1	Gasket set
14	623.065.00	1	Float chamber, complete
15	623.095.00	1	Cap
16			Refer to fig. 13
17			Refer to fig. 13
18			Refer to fig. 13
19			Refer to fig. 13
20			Refer to fig. 13
21	623.060.00	2	Float clamp screw
--	715.102.00	1	Carburettor assy Dell'Orto PHVA 12 - PS / R 6330