

VOLANI E STATORI MOTOCICLI 50 MOTORI YAMAHA/MINARELLI-DERBI

MOTORE MINARELLI 50 AM345/AM6 S/AVV.TO ELETTRICO (IMPIANTO DUCATI)



- 31.1013** volano Ducati 6 poli 100W - rotore Ø 103
cono 15,8 - piastra Ø 94 - rotazione sx (antioraria) max 12.000 giri (fig. 1+2)
- 31.96849** statore Ducati 6 poli c/pick-up interno - c/piastra (fig. 2)

Di primo equipaggiamento su:

- Aprilia** 50 AF1 (s/avv. el. - solo volano completo)
50 ET/Tuareg (s./avv. el. - solo volano completo)
50 Red Rose (s./avv. el. - solo volano completo)
50 RX (89/90 - s./avv. el.)
50 RX (91/94 - 3/5 marce)
50 RX Enduro/Racing (95/06)
50 MX Motard (02/05)
- HM** 50 CRE Six/Baya/Derapage (95/05 - s/avv.to elettrico)
- Malaguti** 50 XTM (03/06)
50 XSM (03/06)
50 Fifty Full LX/Top/Up
50 JX/MRX
50 MGX/MFX/MLX (solo volano completo)
- MBK** 50 X-Limit Enduro/Motard (03/06)
- Peugeot** 50 XPS T (03/06)
- Rieju** 50 MRX/Pro (00/05)
50 RR/Spike/Sport (98/05)
50 SMX (05)
- Yamaha** 50 DT R/SM (03/06)

Rif. Aprilia: AP8212564 (8222079/059/084/8212475/476/8212258/8206533/8206368)

Rif. Ducati: 31101310 (ex 310812/311012 - sostituisce 31091104/310912/310852)

Rif. Malaguti: 78202200

Rif. MBK/Yamaha: 1D4H554000

MOTORE MINARELLI 50 AM6 S/AVV.TO ELETTRICO (IMPIANTO DUCATI DIGITALE)



- 31.143502** statore Ducati 12 poli c/pick-up interno - c/piastra Ø 94 (fig. 2)
- 31.143501** rotore Ducati Ø 103 - cono 15,6 - rotazione dx - max 14.000 giri (fig. 1)

Di primo equipaggiamento su:

- HM** 50 CRE Six (06/09 - c/impianto Ducati)
50 CRE Derapage Competition (06/09 - c/impianto Ducati)

Rif. HM: 8520053 (statore) • 8203008 (rotore)

Rif. Ducati: 31143501 • 31143502

MOTORE YAMAHA/MINARELLI 50 AM6 "POWER-UP" (IMPIANTO YAMAHA DIGITALE)



- 16.3082** Statore 12 poli - c/piastra - c/pick-up completo

Per:

Betamotor 50 RR AM6 Power-Up (07/10 - s/avv.to elettrico - imp. Yamaha)

Fantic Motor 50 Caballero Motard
50 Caballero Regolarità Casa
60 Caballero Regolarità Competizione

HM 50 CMC (10/11)
50 CRE Baja (06/12)
50 CRE Baja RR (07/12)
50 CRE Baja Basic (10/11)
50 CRE Derapage (06/12)
50 CRE Derapage RR (07/12)
50 CRE Derapage Basic (10/11)
50 CRE Derapage Competition (10/12)
50 CRE SIX Competition (10/12)

Husqvarna 50 CH Racing/SM

Malaguti 50 XSM Power Up (07/10)
50 XTM Power Up (07/10)

MBK 50 X-Power (03/10)
50 X-Limit Enduro (07/10)
50 X-Limit SuperMotard (07/10)

Peugeot 50 XP6/XPS
50 XR7 (08/>)
50 NK7 (10/>)

Rieju 50 MRT (07/15)
50 MRX (07/15)
50 RS (07/15)
50 RR Enduro (07/15)
50 SMX (07/15)
50 Spike (07/15)

Sherco 50 HRD Enduro
50 HRD Super Motard

Yamaha 50 TZR/RR (03/12)
50 DT R Enduro (07/10)
50 DT X SuperMotard (07/10)

Rif. Yamaha: 5WX-H1410-00

Rif. Malaguti: 782032000 (volano completo)

Rif. HM: 8205014

MOTORE MINARELLI 50 AM345 C/MOTORINO AVV.TO EFEL (IMPIANTO DUCATI)



31.96469 statore Ducati 6 poli c/pick-up interno - s/piastra (fig. 2)

Di primo equipaggiamento su:

- | | | |
|----------------|-----------------------------|------------------------------|
| Aprilia | 50 AF1 Project 108 (88) | 50 Red Rose (89/92) |
| | 50 AF1 Replica/Sintesi (89) | 50 RX (89/90 - c/avv. el.) |
| | 50 AF1 Europa/Futura (90) | 50 Tuareg/Rally/Wind (88/92) |

Rif. orig.: AP8212710 (8212221/8212257/8212478/8212251/8222075/8222081)

Rif. Ducati: 31082000 (sostituisce 310920/311020/310850)

MOTORE MINARELLI 50 AM345 C/MOTORINO AVV.TO MITSUBA (IMPIANTO DUCATI)



31.1027 volano Ducati 6 poli 100W - rotore Ø 103 - c/corona cono 15,8 - piastra Ø 94 - rotazione sx max 12.000 giri (fig. 1+2)

31.96849 statore Ducati 6 poli c/pick-up interno - c/piastra (fig. 2)

Di primo equipaggiamento su:

- | | | |
|-----------------|------------------------------|---------------------------|
| Aprilia | 50 AF1 Europa/Futura (91/92) | 50 Pegaso (92/94) |
| | 50 Classic (92/99) | 50 RS (93/98 - 3/5 marce) |
| Malaguti | 50 Fifty Evolution (90/93) | |

Rif. Aprilia: AP8212565 (8206532/8222262/8212479/8212519)

Rif. Ducati: 31102701 (ex 310825/311025)

Rif. Malaguti: 02402800

MOTORE MINARELLI 50 AM6 C/AVV.TO ELETTRICO (IMPIANTO DUCATI)



31.1028 volano Ducati 6 poli 100W - rotore Ø 103 - c/corona cono 15,8 - piastra Ø 94 - rotazione sx (antioraria) max 12.000 giri (fig. 1+2)

31.96849 statore Ducati 6 poli c/pick-up interno - c/piastra (fig. 2)

Di primo equipaggiamento su:

- | | | |
|-----------------|---|-----------------|
| Aprilia | 50 RS (95/05 - 6 marce) | |
| | 50 Tuono (03/05) | |
| HM | 50 CRE Baya/Derapage (03/05 - c/avv.to elettrico) | |
| Malaguti | 50 CNK Drakon (05/>) | |
| Peugeot | 50 XPS-SM/XR6-E (03/06) | |
| Rieju | 50 RS2 Matrix/Pro (03/05) | 50 SMX (01/04) |
| | 50 RS2 Naked (05) | 50 SMX Pro (05) |

Rif. Aprilia: AP8206625

Rif. Ducati: 31102801 (ex 311026)

Rif. Malaguti: 78202706

MOTORE DERBI 50 S/AVV.TO ELETTRICO



16.8513 • volano completo 12V/85W - rotore Ø 103 cono 15,5 - rotazione sx - piastra Ø 94 (fig. 1+2)

16.8013 • statore 6 poli c/pick-up interno - c/piastra (fig. 2)

Per:

Aprilia RX 50 (06/17)

SX 50 (06/17)

Derbi 50 Bultaco Lobito (98/01 - impianto Ducati)

50 Senda L (93/97)

50 Senda R (95/98)

50 Senda R/SM/DRD/X-Trem/R Racer (97/03 - impianto Ducati)

50 Senda Black Edition (03)

50 Senda SM/R DRD Racing LTD/E2 (04/13)

50 Senda SM DRD Edition Black (05)

50 Senda SM/R X-Trem/E2 (04/15)

50 Senda SM/R X-Race/E2 (05/13)

50 Senda Hyp DRD Evo EU2 (08/13)

Rif. Derbi: 00H0331101/00701

Rif. Aprilia/Derbi: 82829R

Rif. Ducati: 310843

MOTORE DERBI/PIAGGIO 50 6 MARCE C/AVV.TO ELETTRICO



16.8536 • volano completo 12V/85W - rotore Ø 103 - c/corona cono 15,5 - rotazione sx - piastra Ø 94 (fig. 1+2)

16.8036 • statore 6 poli c/pick-up interno - c/piastra (fig. 2)

Per:

Aprilia 50 RS (06/13 - mot. Derbi)

50 RS4 (11/17)

Derbi 50 Senda R/SM DRD Pro E2 (05/13 - c/avv.to elettrico)

50 Senda Hyp DRD Evo Limited Ed. (08)

50 GPR Nude/Nude Sport (06/07)

50 GPR Racing E2 (06/07)

50 GPR Replica E2/R EU2 (06/09)

50 GPR Nude Tuning (06/09)

50 GPR R EU2 (08/09)

50 GPR 2T (13)

Rif. Aprilia/Derbi: 847065/82852R

Rif. Ducati: 310860

VOLANI E STATORI SCOOTER MOTORI APRILIA - CF MOTO - MINARELLI F. MORINI - ROTAX - SUZUKI - YAMAHA

MOTORE APRILIA 50 DITECH (IMPIANTO DUCATI)

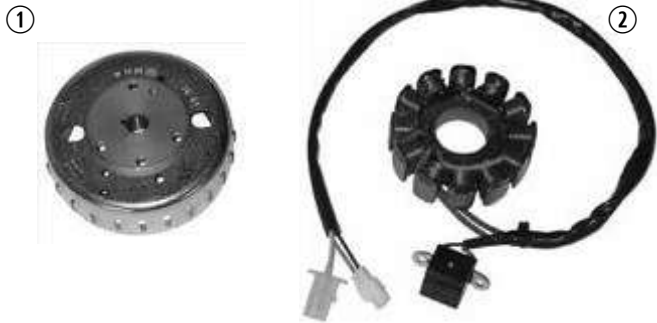

- 31.14502** statore Ducati 12 poli c/pick-up - a 2 cavi - 140W (fig. 2)
31.14501 rotore Ducati - rotazione dx - Ø 103,85 - cono 16,35 (fig. 1)

Di primo equipaggiamento su:

- Aprilia** 50 SR Ditech/Euro 2 (00/04)
 50 SR New Ditech (04/06)
 50 SR R Factory (04/06 - mot. Aprilia)
 50 Scarabeo Ditech (01/06)
Suzuki 50 Katana Iniezione (05/06)

Rif. Aprilia: AP2RBA000075 • AP5RSR000228

Rif. Ducati: 311450 (volano)

Rif. Suzuki: 32100-02EAO

N.B.: può sostituire impianto **Mitsuba** solo utilizzando statore e rotore.

MOTORE MINARELLI 50 2T (IMPIANTO DUCATI)



- 31.96869** statore Ducati 6 poli c/piastra - Ø 118 - c/pick-up interno (ex 31.96791)

Di primo equipaggiamento su:

- Aprilia** 50 Scarabeo (93/97 - c/imp. Ducati)

Rif. Aprilia: AP8212701 (volano)

Rif. Ducati: 311063 (volano)

MOTORE MINARELLI 50 2T (IMPIANTO DUCATI)



- 31.96844** volano Ducati 6 poli c/piastra Ø 103 - 100W
 rotazione dx - piastra Ø 118 - cono 15 (ex 31.1062) (fig. 1+2)
31.96744 statore Ducati c/piastra 6 poli - c/pick-up interno (ex 31.96790) (fig. 2)
16.967447 statore adattabile s/piastra 6 poli - c/pick-up interno (fig. 2)

Di primo equipaggiamento su:

- Beta** Tempo
 Quadra
 Chrono
 Ark/LC (</01)
Malaguti 50 F10 (94/02)
 50 F12 (</01)
 50 F15 (</01)
 50 Ciak/TD (</02)
 50 Centro/SL/Cat. (94/00 - c/imp. Ducati)
 50 Yesterday
Rieju 50 First/F10
 50 Windy

Rif. Beta: 310325000

Rif. Malaguti: 78201800

MOTORE MINARELLI 50 2T EURO 2/2.3 (IMPIANTO DUCATI DIGITALE CBC)



- 31.142012** statore Ducati 12 poli c/piastra Ø 118 - 140W - c/pick-up esterno (fig. 2)
31.142011 rotore Ducati Ø 103 a 2 tacche - cono 15 - rotazione dx (fig. 1)

Impianto "blu" e impianto "verde" sistema "CBC" Euro 2 Euro 2.3 di primo equipaggiamento su:

- Malaguti** 50 F10 RST Euro 2.3 (03/05)
 50 F12 RST/LC/Euro 2/2.3 (02/05)
 50 F15 Euro 2/RST Euro 2.3 (02/04)
 50 Ciak Euro 2.3 (03/05)

Rif. Malaguti (volano): 78202100

Rif. Ducati: 142010 (rotore)

MOTORE MINARELLI 50 2T EURO 2

(IMPIANTO DUCATI)

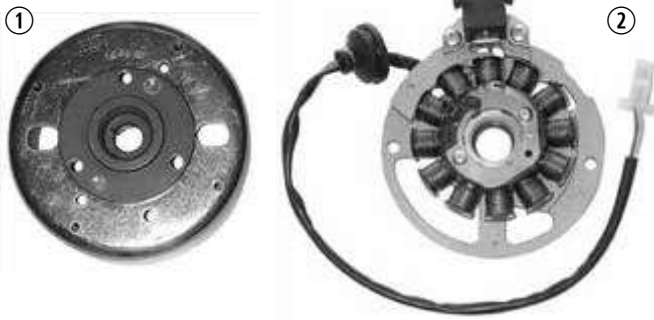

31.142012 statore Ducati 12 poli c/piastra Ø 118 - 140W - c/pick-up esterno (fig. 2)

31.141441 rotore Ducati Ø 103 a 1 tacca - cono 15 - rotazione dx (fig. 1)

Impianto "rosso" di primo equipaggiamento su:

- Malaguti** 50 F10 RST Euro 2 (06/07)
 50 F12 Air/LC RST Euro 2 (06/07)
 50 F15 LC RST Euro 2 (04/05)
 50 F15 Firefox Air (05/07)
 50 F15 Ciak 2t Master Euro 2 (06/10)
 50 Phantom F12 R-LC (07/10)

Rif. Malaguti (volano): 78202600

Rif. Ducati: 141440 (rotore)

MOTORE MINARELLI/YAMAHA 50 2T

CILINDRO VERTICALE (IMPIANTO YAMAHA)



16.3055 statore 7 poli c/piastra e pick-up esterno - lunghezza cavi 150 cm.

Per motori Yamaha/Minarelli 50 2t (c/cilindro verticale):

- Aprilia** 50 SR Air Urban/Viper/Replica (93/96)
 50 Amico/LK/LX/GL/Sport (92/98)
- MBK** 50 Booster/Spirit/NG/Rocket/Track/Road (90/02)
 Stunt (00/02)
- Yamaha** 50 BW'S/Original/Next Generation/Bump/Spy (95/02)
 50 Slider (00/02)

Rif. MBK/Yamaha.: 4SB-85560-00 • 3ES-85560-01

MOTORE MINARELLI/YAMAHA 50 2T

CILINDRO ORIZZONTALE (IMPIANTO YAMAHA)



16.3585 volano completo 7 poli c/piastra - rotazione dx
 piastra Ø 118 - cono 15 - lung. cablaggi 40 cm. (fig. 1+2)

16.35851 volano completo 7 poli c/piastra - rotazione dx
 piastra Ø 118 - cono 15 lung. cablaggi 60 cm. (fig. 1+2)

16.3085 statore 7 poli c/piastra (cabl. 40 cm.) (fig. 2)

16.30851 statore 7 poli c/piastra (cabl. 60 cm.) (fig. 2)

Per motore Minarelli/Yamaha 50 2T (c/cilindro orizzontale):

- Aprilia** 50 SR (94/01)
 50 Scarabeo (93/05 - c/imp. Yamaha)
 50 Rally/LC
 50 Gulliver
 50 Area 51
 50 Sonic
- Beta** 50 Eikon
- Benelli** 491 (</02)
 50 K2
 50 Pepe
 Naked (</02)
- Italjet** 50 Dragster
- Malaguti** 50 F10 (92/93)
 50 Centro Base/SL (93/98 - c/imp. Yamaha)
- MBK** 50 Flipper (<02)
 50 Nitro (<02)
 50 Ovetto (<02)
 Evolis
 Fizz
 Forte
 Target
 New Sorriso
 100 Booster (solo statore)
- Yamaha** 50 Why (<02)
 50 Aerox (<02)
 50 Neo's (<02)
 Breeze
 Axis
 CT SS
 CR Z
 Jog (95/96)
 100 BW'S (solo statore)

Rif. Aprilia: 8206462

Rif. Malaguti: 78201600

Rif. MBK/Yamaha: 2JA8555000/3KJ8556000

3XGH556000/4DYH555000

MOTORE MINARELLI/YAMAHA 50 2T EURO 2

(IMPIANTO YAMAHA DIGITALE)



16.3072 statore 12 poli s/piastra - c/pick-up a 2 cavi - c/cavo 40 cm.

Per motori Yamaha 50 2t Euro 2 (c/cilindro orizzontale):

- Yamaha** 50 CS Jog R/Euro 2 (02/13)
- 50 YH Why Euro 2 (03/10)
- 50 YN Neo's/R/Euro 2 2T (02/13)
- 50 YQ Aerox/L Euro 2 (03/13)

- MBK** 50 Flipper (03/>)
- 50 Mach-G (02/>)
- 50 Nitro (03/>)
- 50 Ovetto (02/>)

- Betamotor** 50 ARK AC/LC/Factory/Skull/Razor/One (09/13)

Rif. MBK/Yamaha.: 5BM-H1410-02

Rif. Beta: 3301054000

MOTORE MINARELLI/YAMAHA 50 2T EURO 2

(IMPIANTO YAMAHA DIGITALE)



16.3073 statore 12 poli s/piastra - c/pick-up a 2 cavi - c/cavo 110 cm.

Per motori Yamaha 50 2t Euro 2 (c/cilindro verticale):

- MBK** 50 Booster Naked (03/>)
- 50 Booster Spirit Euro 2 (03/>)
- 50 Booster Spirit L (03/>)
- 50 Booster NG (03/>)
- 50 Booster (04/>)

- Yamaha** 50 BW'S Naked (03/>)
- 50 BW'S Next Generation/Cat. (03/06)
- 50 BW'S Original Euro 2 (03/>)
- 50 CW L BW'S (03/04)
- 50 BW'S (04/16)
- 50 BW'S Naked (04 - 09/16)

Rif. MBK/Yamaha.: 5WWH1410000 • 5RHH14100000

MOTORE F. MORINI 50 2T / MOTORE DERBI 50 2T /

MOTORE SUZUKI 50 2T (IMPIANTI IDM / KOKUSAN / LEONELLI/SHILING)



16.3587 volano Leonelli 4 poli s/piastra Ø 103 - rotazione dx - cono 16 - 4 cavi (cavo azzurro di massa)

Per:

- Benelli** 491 (03/>)
- Naked (03/>)
- Cagiva** Cucciolo 50
- Progress 50/LC
- Derbi** Vamos 50
- Hunter 50
- Paddock 50
- Predator 50/LC
- Atlantis 50/LC/100
- Italjet** Torpedo 50 2T
- Formula 50
- Velocifero 50
- Malaguti** Crosser CRI 50
- Piaggio** Diesis 100
- Rizzato** 50 Byte
- 50 Hacker
- 50 Skeggia
- Suzuki** AP 50 R/T
- AH 50 Address
- AJ 50 Sepia/ZZ

Rif. Derbi/Cagiva: 00G03301801/01011/02011/03011

Rif. Italjet: 338290125

Rif. Malaguti: 62014200

Rif. Suzuki: 32101-29C03/32102-29C02

MOTORE F. MORINI 50 2T

(IMPIANTO IDM)



16.3086 Statore 4 poli Ø 79,30 mm - 4 cavi

Per

- mot. **Franco Morini** AH50 aria/acqua su:
- Atala-Rizzato** 50 Byte AT10
- 50 Skeggia
- Benelli** 50 491 Morini RR/ST (03/04)
- 50 Naked Morini (03/04)
- Cagiva** 50 Cucciolo (98/99)
- Italjet 50** Formula/LC (94/00)
- 50 Torpedo 2t (96/99)
- 50 Velocifero (93/99)
- Malaguti** 50 Crosser CRI (95/99)

Rif. Italjet: 338290125

Rif. Malaguti: 62014200

MOTORE SUZUKI 50 2T
(IMPIANTI KOKUSAN-SHILING)



16.3087 Statore 4 poli Ø 83,40 mm - 3 cavi

Per:

- Suzuki** 50 AH Address (92/95)
- 50 AJ Sepia/AJ ZZ (95/97)
- 50 AP (94/97)

Rif. orig.: 32101-29C03

MOTORE SUZUKI 50 2T
(IMPIANTO DUCATI)



31.1411 volano Ducati 12 poli - 120W
rotazione dx - Ø 103 - cono 16 (fig. 1+2)

Di primo equipaggiamento su:

- Suzuki** Katana 50/LC (</04)
- Zillion 50

Rif. Suzuki: 32100-35E00

Rif. Ducati: 31141100/31141410/31141420

MOTORE SUZUKI 125/150 4T
(IMPIANTO KOKUSAN)



16.8555 volano completo Kokusan 18 poli trifase - Ø 118
200W - c/pick-up a 2 cavi (fig. 1+2)
statore Ø est. 92,9 - Ø int. 35,3
rotore Ø est. 117,8 - cono 19,7

Di primo equipaggiamento su:

- Suzuki** AN 125 (96/>)
- UE 125/150

Rif. orig.: 32101/102 • 20E20

MOTORE APRILIA 125/200 4T CARBURATORE
MOTORE F. MORINI 400



16.8543 • volano completo 220 W - Ø 112,2 - cono 21,5
18 poli trifase (fig. 1+2)

16.8043 • statore 18 poli - c/pick-up a 1 cavo
Ø est. 94,8 - Ø int. 34,9 (fig. 2)

Per:

- Aprilia** Scarabeo 125/200 Light (07/09 - carb.)

Adattabile su:

- Benelli** Velvet 400 (solo statore)
- Malaguti** Madison 400 (solo statore)

Rif. Aprilia: AP2RBA000722 • AP2RBA000723

MOTORE APRILIA 125/200 4T INIEZIONE



16.8575 • volano completo 18 poli trifase - Ø est. 112,4 - cono 22 mm. (fig. 1+2)

16.8075 • statore 18 poli - Ø est. 94,7 - Ø int. 34,9 - c/pick-up a 2 cavi (fig. 2)

Per:

- Aprilia** 125/150 Scarabeo Light IE (09/16 - iniezione)

Rif. orig.: JC32100X05300

MOTORE ROTAX 125/150/200 4T
(IMPIANTO DENSO)



16.3068 statore 18 poli trifase completo - Ø est. 93 - Ø int. 34,8
c/pick-up a 2 cavi

Per:

- Aprilia** Leonardo 125/150/ST (96/04)
- Scarabeo 125/150/200/GT (99/04 - mot. Rotax)

Rif. Aprilia: AP0295550 • AP0295555 • AP0684300 (volano completo)

Rif. Denso: 037000-3470 (LKZ33/12Z)

MOTORE CF MOTO 125/150 4T INIEZIONE (IMPIANTO DUCATI)



35.19022 statore Ducati 18 poli trifase - Ø est. 94,8 - Ø int. 35 c/pick-up a 2 cavi (fig. 1)

35.19021 rotore Ducati - Ø 112 - cono est. 19,5 mm. (fig. 2)

Di primo equipaggiamento su:

CF Moto 125/150 E-Charm (iniezione)
125/150 Glory (iniezione)

Malaguti Centro 125/160/SL ie (07/10)
Blog 125/160 ie (09/10)

WT Motors 125/150 Atene (iniezione)

Rif. Malaguti: 65051000/6505900

Rif. Ducati: 35190021/35190022

MOTORE YAMAHA 125 4T (IMPIANTO YAMAHA)



16.3060 statore trifase 11 poli - c/bobina alimentazione - c/pick-up a 2 cavi

Per:

MBK XC 125 Flame/Flame T/K Flame R (95/03)

Yamaha XC 125 Cignus/Cignus T/K Cignus R (95/03)

Rif. orig.: 4CW-H5510-00

MOTORI YAMAHA/MINARELLI 125/150/180 4T (IMPIANTI YAMAHA/DUCATI)



16.3061 statore trifase 16 poli - c/bobina alimentazione - c/pick-up a 2 cavi

Per:

Benelli Velvet 125/150 (99/07)

Italjet Millenium 125/150 (00/02)
Jupiter 125/150

Malaguti Madison 125/150 (99/05)
F12 Max 125

Yamaha/

MBK Majesty/Skyliner 125/150/180
Teo's/Doodo 125/150
Maxster/Thunder 125/150

Rif. Yamaha/MBK: 5DS-85510-00

MOTORI YAMAHA/MINARELLI 125 INIEZIONE (IMPIANTO YAMAHA)



16.3077 statore 18 poli trifase - c/pick-up a 2 cavi

Per:

MBK 125 Cityliner (07/>)
125 Skycruiser/ABS/Sport (06/>)

Yamaha 125 X-Max (06/16)
125 X-City (08/16)

Rif. orig.: 1B9H141000

MOTORI YAMAHA 250 4T (IMPIANTO MITSUBISHI)



16.3069 statore 18 poli trifase - c/pick-up a 2 cavi - Ø est. 93 mm. - Ø int. 35 mm.

Per:

Aprilia Leonardo 250/ST (99/01)

Benelli Velvet 250/Touring (99/03)

Linhai 250/260/300
Aeolus/Monarch/Freedom/Viper/Mainstreet/Cruiser/Roadrunner

Malaguti Madison S 250 (99/03)

Yamaha Majesty 250 (96/98)
Majesty 250 DX (98/00)

Rif. Aprilia: AP8122629

Rif. Benelli: R18040691A0

Rif. Linhai: 24001/169.07.100

Rif. Malaguti: 98200100

Rif. Mitsubishi: F4T252

Rif. Yamaha: 4HC814100100

MOTORI YAMAHA 250 4T
(IMPIANTO MITSUBISHI)



- 16.3059** statore 18 poli trifase - c/pick-up a 2 cavi - Ø est. 104 mm. - Ø int. 42 mm.
16.1605 • statore giapponese 18 poli trifase - c/pick-up a 2 cavi

Per:

- Aprilia** Leonardo 250/ST (02/04)
Leonardo 300
MBK Skyliner 250
Yamaha Majesty 250 (00/06)

Rif. Aprilia: AP8552112 • AP8127493
Rif. MBK/Yamaha: 5GM-81410-00
Rif. Mitsubishi: F4T370

MOTORE YAMAHA 250 4T - INIEZIONE
(IMPIANTO YAMAHA)



- 16.3080** Statore 18 poli - trifase c/pick-up

Per:

- Yamaha** 250 YP R X-Max ie/Black X-Max (07/12)
250 YP R X-Max ABS/Sport (11/16)
250 VP X-City (07/15)
Malaguti 250 Password ie Euro 3 (07/10)
MBK 250 Skycruiser (11/15)

Rif. Yamaha: 1C0-H1410-10

MOTORE SUZUKI 250/400 INIEZIONE
(IMPIANTO DENSO)



- 16.3004** Statore 18 poli con pick-up

Per:

- Suzuki** Burgman 250/400 (03/06)

Rif. orig.: 32101-14G00

MOTORE SUZUKI 400 INIEZIONE
(IMPIANTO DENSO)



- 16.3005** Statore 18 poli con pick-up

Per:

- Suzuki** Burgman 400 (07/12)

Rif. orig.: 32101-15G51

MOTORI YAMAHA 500 4T CARBURATORE
(IMPIANTO MITSUBISHI)



- 16.3070** statore 18 poli trifase - c/pick-up a 2 cavi
16.1606 • statore giapponese 18 poli trifase - c/pick-up a 2 cavi

Per:

- Yamaha** XP 500 T-Max (01/03)

Rif. Mitsubishi: F4T373
Rif. Yamaha: 5GJ-81410-01

MOTORI YAMAHA 500 4T INIEZIONE
(IMPIANTO MITSUBISHI)



- 16.3071** statore 18 poli trifase - c/pick-up a 2 cavi
16.1611 • statore giapponese 18 poli trifase - c/pick-up a 2 cavi

Per:

- Yamaha** XP 500 T-Max (04/07)

Rif. Mitsubishi: F4T383
Rif. Yamaha: 5VU-81410-0

MOTORI YAMAHA 500 4T INIEZIONE
(IMPIANTO MITSUBISHI)



16.1601 • statore giapponese 18 poli trifase - c/pick-up a 2 cavi

Per:

Yamaha XP 500 T-Max (08/11)

Rif. orig.: 4B5-81410-00

MOTORE SUZUKI 650
(IMPIANTO DENSO)



16.3007 Statore 18 poli con pick-up

Per:

Suzuki Burgman 650 (13/16)

Rif. orig.: 32101-26J00

MOTORE YAMAHA 530 4T INIEZIONE
(IMPIANTO YAMAHA)



16.3075 Statore 18 poli trifase c/pick-up

Per:

Yamaha 530 T-Max/ABS (12/16)

Rif. orig.: 59C-81410-00

MOTORE SUZUKI 650
(IMPIANTO MITSUBISHI)



16.1702 Statore giapponese 18 poli trifase

Di primo equipaggiamento su:

Suzuki 650 Burgman (03/12)

Rif. orig.: 32101-10G00

VOLANI E STATORI SCOOTER MOTORI KYMCO/SYM

MOTORE KYMCO 50 2T



16.3062 statore 8 poli - Ø est. 88 - Ø int. 29 - c/pick-up a 1 cavo

Per:

Kymco People 50/50 S 2T (99/16)

Rif. orig.: 31120-KFA6-900/00103300

MOTORI KYMCO 125/150 4T - ARIA



16.3063 statore 8 poli - Ø est. 88 - Ø int. 29 - c/pick-up a 1 cavo

Per:

Kymco People 125/150/Euro 2 (99/06)
People 125/150 Euro 3 (07/13 - solo statore)

Malaguti Ciak 125/150/Master/RST/Euro 2 (99/05)

Rif. Kymco: 31120-KHB4-90A/00123300 (statore) • 31110-KDU-900/00128171 (rotore)

Rif. Malaguti: 5820500/400

MOTORI KYMCO 125/150 4T - ARIA



16.3564 volano completo 8 poli Ø 110,9 - cono 19 - rotazione dx (fig. 1+2)

16.3064 statore 8 poli - Ø est. 88 - Ø int. 29 - c/pick-up a 1 cavo (fig. 2)

Per:

Kymco Movie 125/150/XL/Euro 2 (98/06)
Vivio 125/150
Agility 125/Euro 2/Euro 3 (05/13 - ruote 12")
Agility 125 Carry 4T (11/13 - solo statore)

Rif. orig.: 31110-KDU-900/00128171 (rotore) • 31120-KDU-900/00128172/00128214 (statore)

MOTORI KYMCO 125/150 4T - ARIA



16.3078 statore 8 poli - c/pick-up a 1 cavo

Per:

Kymco 125/150 Agility R16 (08/13 - ruote 16)
125/150 Super 8
125 Agility RS (09/13 - ruote 12)
125 Like (09/13)
125 Like LX (12/13)

Rif. orig.: 00131053 • 31120LFC3E10 • 31120LEJ3E0A/E10

MOTORI KYMCO 125/150 4T - LIQUIDO



16.3056 statore trifase 11 poli - c/pick-up - c/2 bobine alimentazione

Per:

Betamotor Eikon 125/150

Kymco Heroism 125/150 (95/00)
Dink 125/150/LX/Classic/Euro 2 (97/07)
Gran Dink 125/150/Euro 2 (01/07)
Bet&Win 125/150/Euro 2 (00/07)

Malaguti F18 Warrior 125/150

Rif. Kymco: 00128947/00129747 • 31120-KBE-9000/31120-KAF-900

Rif. Malaguti: 00128947

MOTORI KYMCO 125/200 4T CARBURATORE - LIQUIDO



16.3057 statore trifase 11 poli - c/pick-up - s/bobina alimentazione

Per:

Kymco Dink 125 Euro 3 (06/13 - carb.)
Dink 200 Classic/Euro 2 (04/07 - carb.)
Gran Dink 125 Euro 3/S (08/10)

Rif. orig.: 00128039 • 31120-KKC2-81A

MOTORI KYMCO 125/200 4T CARBURATORE - ARIA

16.3053 statore 12 poli - Ø est. 88,5 - Ø int. 29 - c/pick-up a 1 cavo

Per:

Kymco 125 People S (05/07)
125 People S DD Euro 3 (07/13)
200 People S (05/08 - Carb.)
Malaguti 125 Ciak Master Euro 3 (06/09)
200 Ciak Master Euro 2 (06/08)

Rif. Kymco: 00128184 • 31120-LCD3-E0B

Rif. Malaguti: 58200700

MOTORI KYMCO 250 4T CARBURATORE

16.3058 statore trifase 18 poli - Ø est. 91,8 - Ø int. 34,7 - c/pick-up a 2 cavi

Per:

Daelim S2 250
Kymco Gran Dink 250/Euro 2
Bet&Win 250/Euro 2
People 250 LC (03/07)
People S 250 (05/07 - carb.)
Yup 250

Rif. Kymco: 00128937 • 31120-KKC4-90A • 00128544 • 31120-KHE7-90A • 00169320 • 31120-LDHI-E00 • 00169149 • 31120-LDB2-E00

Rif. Daelim: 31120-SZ1-900

MOTORI KYMCO 250 4T CARBURATORE

16.3079 Statore 18 poli trifase c/pick-up 2 cavi

Per:

Kymco 250 X-Citing (05/06)

Rif. orig.: 00169149

MOTORI KYMCO 250/300 4T INIEZIONE

16.3074 statore trifase 18 poli completo - Ø est. 97,5 - Ø int. 34,9 - c/pick-up a 2 cavi

Per:

Kymco People S 250 ie (06/08)
People S 300 ie (09/13)
X-Citing 250 ie (06/08)
X-Citing 300 ie/R (09/13)

Rif. orig.: 31120-LDF2-90A • 00169230

MOTORI SYM 125/150 4T

16.3054 statore 8 poli - Ø est. 88 - Ø int. 29 - c/bobina alimentazione c/pick-up a 1 cavo

Per:

Sym New Duke 125 (00/02)
Euro MX 125/150/EU2 (02/05)
Shark 125/150 (99/02)

Rif. orig.: 31120-H3A-010

MOTORI SYM 125/150/200 4T CARBURATORE

16.3067 statore trifase 11 poli - c/pick-up a 2 cavi - c/2 bobine alimentazione

Per:

Adiva 125 AD Euro 3/LE/AR (09/10)
Laverda 125/150/200 Phoenix
Peugeot LXR 125
Sym Joyride 125/150/Euro 3 (01/09)
125 Joyride Evo (09/13)
HD 125/Evo/Euro 3 (03/13)
125 HD2 (11/13)
200 Joyride/Euro 2 (03/06 - carb.)
200 HD/Evo/Euro 2 (03/06 - carb.)

Rif. Laverda: 8900719

Rif. Sym: 31120-H9A-001

VOLANI E STATORI SCOOTER MOTORI HONDA/PEUGEOT

MOTORI HONDA 50 2T (IMPIANTO DUCATI)



31.96828 statore Ducati 12 poli completo - Ø est. 84 - Ø int. 30 - c/pick-up

Di primo equipaggiamento su:

Honda Sky 50/De Luxe/50th (97/>)

Rif. Ducati: 311412 (volano)

Rif. Honda: 31120-GCG-930 (statore)

MOTORE HONDA 125/150 4T CARBURATORE (IMPIANTO MITSUBA)



16.3090 statore Mitsuba trifase 18 poli - Ø est. 94,6 - Ø int. 34,9 - s/pick-up (fig. 1)

16.30901 statore 18 poli trifase - adattabile

16.3290 pick-up completo 2 cavi c/connettore (fig. 2)

Di primo equipaggiamento su:

Honda Chiocciola@ 125/150 (no modello stop&go - 00/07)
Dylan 125/150 (02/05)
SH 125/150 (01/04)

Rif. orig.: 31120-KGF-912 (statore) • 30300-KGF-910 (pick-up)

MOTORE HONDA 125/150 4T INIEZIONE (IMPIANTO MITSUBA)



16.3094 statore Mitsuba trifase 18 poli - Ø est. 94,6 - Ø int. 34,9 - s/pick-up (fig. 2)

16.3494 rotore Mitsuba Ø 112 mm. - cono 21,5 (fig. 1)

Di primo equipaggiamento su:

Honda Pantheon 125/150 4T (03/06)

Rif. orig.: 31120-KRJ-901 (statore) • 31110-KRJ-901 (rotore)

MOTORE HONDA 125/150 4T INIEZIONE (IMPIANTO MITSUBA)



16.3095 statore Mitsuba trifase 18 poli - Ø est. 94,6 - Ø int. 34,9 - s/pick-up (fig. 2)

16.30957 statore 18 poli trifase - adattabile

16.3494 rotore Mitsuba Ø 112 mm. - cono 21,5 (fig. 1)

Di primo equipaggiamento su:

Honda SH 125/150 Iniezione (05/12)
PS 125/150 i (06/13)

Rif. orig.: 31120-KTF-640 (statore) • 31110-KRJ-901 (rotore)

MOTORE HONDA 125/150 4T INIEZIONE (IMPIANTO MITSUBA)



16.3097 statore Mitsuba trifase 18 poli - Ø est. 94,6 - Ø int. 34,9 - s/pick-up (fig. 2)

16.3494 rotore Mitsuba Ø 112 mm. - cono 21,5 (fig. 1)

Di primo equipaggiamento su:

Honda S-Wing 125/150 (07/13)

Rif. orig.: 31120-KRJ-791(statore) • 31110-KRJ-901 (rotore)

MOTORE HONDA 125 ESP 4T INIEZIONE

16.3091 statore avviamento Mitsuba 18 poli



Di primo equipaggiamento su:

Honda 125 PCX (12/17)
125 SH Mode (14/17)
125 SH/D/A/AD ABS (13/17 - JF41)

Rif. orig.: 31220-K02-901

MOTORE HONDA 150 ESP 4T INIEZIONE

16.3093 statore avviamento Mitsuba 18 poli

Di primo equipaggiamento su:

Honda 150 PCX (13/17)
150 SH/D/A/AD ABS (13/17 - KF13)

Rif. orig.: 31220-K02-D01

MOTORE HONDA 250 4T CARBURATORE

16.9024 Statore 18 poli trifase c/2 bobine alimentazione

Per:

Honda CN 250
Piaggio Hexagon GT 250
Mot. Cina 172MM

Rif. Honda: 31120-KS4-004

MOTORE HONDA 400/600

16.3033 statore 18 poli trifase - s/pick-up
115 x 54 x 20 mm.

Per:

Honda Silverwing 400/600
FJS 400/600 SW-T

Rif. orig.: 31120-MCT-003 • 31120-MEF-003

MOTORE HONDA 300 INIEZIONE (IMPIANTO DENSO/MITSUBA)

16.3098 statore Mitsuba GF13 18 poli trifase - Ø est. 107,3 - Ø int. 41,5
spessore ferro int. 20 - c/pick-up a 2 cavi

Di primo equipaggiamento su:

Honda SH 300 (11/14)

Rif. Honda: 31120-KTW-B01

MOTORE HONDA 300 INIEZIONE (IMPIANTO DENSO/MITSUBA)

16.35981 volano completo Denso 18 poli trifase - c/pick-up a 2 cavi - Ø 126,4
cono 24,0 (fig. 1+2)

Di primo equipaggiamento su:

Honda SH 300 (07/10)

Rif. Denso: LMX75 • 037000-6841 (rotore)

Rif. Honda: 31120-KTW-901

MOTORI PEUGEOT 50 2T (IMPIANTO KOKUSAN)

16.8517 volano Kokusan completo 6 poli - 90W - rotazione dx - Ø 103,6
cono 15,8 (fig. 1+2)

Di primo equipaggiamento su:

Peugeot 50 Ludix 10 One/2 (04/10)
50 Ludix 10 Trand/Snake (04/10)
50 Ludix 10 SP Blaster (05/09)
50 Ludix 14 Classic/Elegant/2 (04/10)
50 Blaster/RS12 (09/10)
Speedfight 50 3 LC (09/10)
Jet Force 50 C-Tech (06/09)
50 Speedfight 4 (15/17)

Rif. orig.: 768349 (760346)

MOTORI PEUGEOT 50 2T (IMPIANTO KOKUSAN)



16.8518 volano Kokusan completo 6 poli (fig. 1+2)

Di primo equipaggiamento su:

- Peugeot** Jet Force 50 C-Tech (10/13)
 Ludix 50 10/14 (10/13)
 Jet Force C-Tech R-Cup/Ice Blade/Dark Side (10/13)
 50 Vivacity 3L 2T (10/13)
 50 Ludix Pro 2T (09/11)
 50 Speedfight 3 Air/RS/N 2T (09/10)
 50 Speedfight 3 LC Ice Blade 2T (11/13)
 50 Speedfight 3 LC Dark Side 2T (11/13)
 50 StreetZone 2T (14/15)

Rif. orig.: 766005

MOTORE PEUGEOT 50/100 2T (IMPIANTO MITSUBA)



16.30371 statore 6 poli 90W - 3 cavi - c/pick-up

Per:

- Peugeot** SV 50/100
 Buxy 50
 Zenith 50
 Squab 50
 Speedake 50
 Trekker 50
 Vivacity 50/Cat. (s/antif. elettr.)
 Looxor 50
 Speedfight 50 Air/LC (97/98)
 X-Race 50
 Speedfight 50 Air Cat. (99 - s/antifurto elettr.)
 Metal X50
 50 TRK2 (04/09)
 X-Fight 50 Air (s/antifurto elettr.)
 50 Jet C-Tech (08/09)
 50 Speedfight 2 Air/LC (05/08)
 Speedfight 100 (s/antifurto elettr.)
 Trekker 100

Rif. orig.: 729957

MOTORE PEUGEOT 50/100 2T (IMPIANTO MITSUBA)



16.3088 statore Mitsuba 8 poli 140W- c/pick-up

Di primo equipaggiamento su:

- Peugeot** Vivacity 50 (c/antifurto elettr.)
 Elyseo 50
 X-Fight 50 LC
 X-Fight 50 Air (c/antif. elettr.)
 Speedfight 50 Air Cat. (99 - c/antifurto elettr.)
 Elyseo 100
 Vivacity 100
 Looxor 100
 X-Fight 100
 Speedfight 100 (c/antifurto elettr.)

Rif. orig.: 740929

MOTORE PEUGEOT 125/150 4T (IMPIANTO MITSUBA)



16.3038 statore Mitsuba 18 poli completo - Ø est. 94,7 - Ø int. 34,8 c/pick-up 1 cavo

Di primo equipaggiamento su:

- Peugeot** Elyseo 125/150

Rif. orig.: 737527

VOLANI E STATORI SCOOTER MOTORI PIAGGIO

MOTORE PIAGGIO 50 2T CARBURATORE ARIA/LIQUIDO



- 16.8530** • volano completo 6 poli - Ø 116,8 - rotazione dx - cono 16 - 90W (fig. 1+2)
16.8030 • statore 6 poli (fig. 2)
16.30307 • statore adattabile (fig. 2)
16.8421 • rotore Ø 116,8 - cono 16,0 (fig. 1)

Per:

- Piaggio** Sfera 50/FL/RST
 Quartz 50
 Free 50/FL Delivery (92/01)
 NTT 50
 NRG 50
 NRG MC2 (96/98)
 Vespa ET2 50
 Zip 50 Base/RST (92/99)
 Zip 50 Fast Rider/RST
 Zip 50 SP (96/99)
 Free 50 FL (98/01)
 Liberty 50 (97/05)
 NRG 50 Extreme (99/00)
 NRG 50 MC3 (aria - 01/04)
- Gilera** Easy Moving 50
 Storm 50
 Stalker 50 (97/02)
 Typhoon 50/X/XR (94/00)
 Runner 50/DD/SP (97/00)

Rif. Piaggio/Gilera: 830293 (volano) • 830294 (statore) • 293492/584526 (rotore)

MOTORE PIAGGIO 50 2T "HI-PER 2" CATALIZZATO EURO 2



- 16.8581** • volano completo 6 poli - Ø 116,8 - rotazione dx - cono 16 - 90W (fig. 1+2)
16.8081 • statore 6 poli (fig. 2)
16.8421 • rotore Ø 116,8 - cono 16,0 (fig. 1)

Per:

- Aprilia** SR 50/R (04/13)
 Sportcity 50 One/Street 2T (08/13)
 SR 50 Motard (12/17)
 SR 50 Street (03/17)
 SR 50 R Factory (10/17 - carb.)
 Scarabeo 50/Street/Net 2T (05/17)
- Derbi** GP1 50/Euro 2 (01/13)
 Atlantis 02 50/Bullet/City/Red Bullet/2 Chic/Euro 2 (02/13)
 Sonar 50 2T (09/13)
 Boulevard 50 2T (09/10)
 Variant Sport 50 2T (12/13)
 Gilera DNA 50 GP/EXP (00/>)
 Ice 50 (01/>)
 Runner 50/FL/Poggiali/SP/Race/SC/ST (02/13)
 Stalker 50/Naked (03/10)
 Storm 50 Euro 2 (07/09)
 Typhoon 50 (01/10)
- Italjet** Jet Set 50
 Torpedo 50 2T (motore Piaggio)
- Piaggio** Liberty 50 PTT Euro 2 (04/>)
 Liberty 50 2T RST/Sport/MOC (04/13)
 Fly 50 2T
 Zip 50 2T Cat. (00/13)
 Zip 50 SP (01/13)
 NRG 50 MC3 acqua (01/04)
 NRG 50 Power DD/DT (05/13)
 Diesis 50
 Typhoon 50 X-R (01/13)
 Vespa 50 LX/LXV/Touring/FL 2T (05/13)
 Vespa 50 S Special 2T (07/13)
 Vespa Primavera 50 2T (13/17)
 Vespa Sprint 50 2T (14/17)

Rif. Aprilia/Derbi/Gilera/Piaggio: 830295/58136R/58037R/827465 (volano) • 584525/639865/830296/827849 (statore) • 293492/584526 (rotore)

MOTORE PIAGGIO 50 4T-4V "HI-PER 4"



- 16.8511** • volano completo 12 poli - 120W - rotazione dx - Ø 103,6 - cono 16 (fig. 1+2)
16.8011 • statore 12 poli - Ø est. 84 - Ø int. 31 - c/pick-up 1 cavo c/connettore 3 pin (fig. 2)

Per:

- Aprilia** Scarabeo 50 Quattro 4T-4V (09/10)
 Scarabeo 50 4T-4V/Net (10/13)
 Sportcity One 50 4T-4V (11/13)
- Piaggio** Vespa 50 S 4T-4V (08/13)
 Vespa 50 LX 4T-4V (09/13)
 Vespa LX 50 Touring 4T-4V (10/13)
 Fly 50 4T-4V (12/13)
 Vespa Primavera 50 4T - 4V (13/17)
 Vespa Sprint 50 4T - 4V (14/17)

Rif. Aprilia/Piaggio: 82798R (volano) • 833632 (statore)

MOTORE PIAGGIO 50 2T INIEZIONE "PUREJET"



- 16.3076** • statore 12 poli - trifase - Ø est. 84 - Ø int. 31 - c/pick-up a 2 cavi

Per:

- Aprilia** SR 50 Street IE (03/17)
 SR 50 R Factory IE (04/17)
- Gilera** Runner 50 Purejet/Race/ST (03/13)
- Piaggio** NRG 50 Purejet/Power Purejet (03/13)

Rif. Aprilia/Piaggio/Gilera: 831372

MOTORE PIAGGIO 50/100 4T-2V "HI-PER 4"



- 31.1452** volano completo Ducati 12 poli - 120W - rotazione dx - rotore Ø 103,6 - cono 16
statore Ø est. 84 - Ø int. 31 - pick-up 1 cavo (fig. 1+2)
- 16.8552** • volano completo 12 poli - rotazione dx - Ø 103,6 - cono 16 (fig. 1+2)
- 16.8052** • statore 12 poli - Ø est. 84 - Ø int. 31 - pick-up 1 cavo (fig. 2)

Per:

- Aprilia** Scarabeo 50 4T (02/09)
Sportcity One 50 4T (08/13)
Scarabeo 100 4T
- Derbi** Atlantis 50 4T
Atlantis 100 4T
Boulevard 50 4T
- Italjet** Torpedo 50 4T
- Malaguti** Ciak 50 4T
Centro 50 4T
- Piaggio** Zip 50 4T
Liberty 50 4T/RST/Sport
Vespa ET4 50
Fly 50 4T 2V (05/12)
Vespa LX/LXV 50 4T 2V (05/10)
Fly 100
Free 100
Zip 100

Rif. Aprilia/Derbi/Piaggio: 9692975 (volano) • 969228 (statore)
Rif. Ducati: 31141520 (volano)

MOTORE PIAGGIO "LEADER" 125 4T INIEZIONE (2V - ARIA)



- 16.8012** • statore 12 poli - trifase - 150W - Ø est. 84 - c/pick-up a 2 cavi c/connettore bianco

Per:

- Piaggio** 125 Liberty ie Euro 3/Elle (11/13 - 2V)
125 Vespa LX IE (09/13)
125 Vespa LX Touring IE (10/13)
125 Vespa LXV IE (10/13)
125 Vespa S Special/College IE (09/13)
150 Vespa LX IE (09/13)
150 Vespa LX Touring IE (10/13)
150 Vespa S Special/College IE (09/13)

Rif. orig.: 640301

MOTORE PIAGGIO "QUASAR" 125 4T INIEZIONE (4V - LIQUIDO)



- 16.8010** • statore 18 poli - trifase - c/pick-up a 2 cavi - c/connettore marrone

Per:

- Piaggio** 125 MP3 Touring ie (fino a 31/08/2011)

Rif. orig.: 642055

MOTORE PIAGGIO L.E.M. 125/150 4T - 3V EURO 3 INIEZIONE - ARIA



- 16.8015** • statore 12 poli trifase

Per:

- Piaggio** 125/150 Fly 4T - 3V IE Euro 3 LEM/DT (12/16)
125/150 Liberty 4T - 3V IE Euro 3 (13/14)
125/150 Liberty 3V IE I-Get (15/17)
125/150 Vespa S 4T - 3V IE Euro 3 (12/14)
125/150 Vespa Special Sport 4T - 3V IE (13/14)
125/150 Vespa LX 4T - 3V IE Euro 3/Touring (12/14)

Rif. orig.: B016453

MOTORE PIAGGIO 125/150 I-GET EURO4 3V - IE - ARIA



- 16.8016** • statore 12 poli trifase

Per:

- Piaggio** 125 Vespa 946 4T - 3V IE ABS (13/17)
125/150 Vespa Primavera / I-Get (13/17)
125/150 Vespa Sprint / Sport / I-Get (15/17)
150 Vespa GTS Super 3V - IE (14/15)

Rif. orig.: 680205

MOTORE PIAGGIO "LEADER" 125 4T
 (2V - ARIA/4V - LIQUIDO)/150/200 (2V - ARIA)

- 16.8528** • volano completo 12 poli trifase - 150W - Ø 101,8 - cono 19 (fig. 1+2)
16.8021 • statore 12 poli - Ø est. 84 - c/pick-up a 1 cavo (fig. 2)

Per:

- Aprilia** Mojito 125/150/Euro 3 (03/09)
 Atlantic 125/Euro 3
 SR 125 Motard
 Scarabeo 125/GT Euro 3 (03/07)
 Sport City 125/Euro 3/One/Cube (04/13)
- Benelli** Adiva 125/150
- Derbi** Boulevard 125/150/200
 125 GP1
 125 Rambla
 125 Sonar
- Gilera** Runner VX 125
 DNA 125
 Nexus 125 (07/08 - carb.)
- Italjet** Torpedo 150
 Jet Set 125/150
- Malaguti** Madison 3 125 (06/>)
- Peugeot** Looxor 125/150
- Piaggio** Vespa ET4 125/150 (00/>)
 Vespa LX/LXV 125/150 (carb.)
 Liberty 125/150/Sport (00/10)
 Liberty 200/Sport
 Skipper ST 125/150 4T
 Zip 125 4T
 Fly 125/150
 Superhexagon GTX 125
 125 MP3 (07/08 - carb.)
 125 Carnaby
 Beverly 125/Sport/Tourer (01/10 - carb.)
 125 X7 (08/10)
 125 X-Evo (07/10)
 X9 125
 X8 125/150
 Vespa GT 125
 Vespa 125 GTS (07/09 - carb.)
 Vespa 125 GTV/Navy (07/09 - carb.)
 Vespa S 125/150 Special (07/10 - carb.)

Rif. Aprilia/Derbi/Gilera/Piaggio: 58130R/58059R/82572R (volano) • 584690/639727/828135/827902/833697 (statore)

MOTORE PIAGGIO "LEADER" 180/200 4T (4V - LIQUIDO)

- 16.8582** • volano completo 12 poli trifase - 170W - Ø 101,8/116 - cono 19 (fig. 1+2)
16.8021 • statore 12 poli - Ø est. 84 - c/pick-up a 1 cavo (fig. 2)

Per:

- Aprilia** Atlantic 200
 Scarabeo 200 (03/07)
 Sport City 200/One/Cube
- Gilera** Runner VXR 180/200
 DNA 180
- Malaguti** Madison 180/200
 F12 Phantom Max 200
- Piaggio** Superhexagon GTX 180
 X9 180 Amalfi
 Beverly 200
 X8 200
 X9 200
 Vespa GT 200
 Carnaby 200

Rif. Aprilia/Gilera/Piaggio: 58060R/82653R/828089 (volano) • 584690/639727/828135/827902/833697 (statore)

MOTORE PIAGGIO "LEADER" 200 4T (4V - LIQUIDO)

- 16.8561** • volano completo 12 poli - trifase (fig. 1+2)

Per:

- Aprilia** 200 Sportcity
 200 Scarabeo
 200 Atlantic
- Gilera** Runner VXR 200/Race/ST
- Piaggio** 200 Beverly
 200 Carnaby
 200 X8
 200 X9
 Vespa GT 200

Rif. orig.: 58141R

Equivalentente **16.8582**

MOTORE PIAGGIO "QUASAR" 250 4T CARBURATORE (4V - LIQUIDO)



16.8501 • volano completo 18 poli trifase - 350W - Ø 112,3/125 - cono 23,8 (fig. 1+2)

16.8001 • statore 18 poli - Ø est. 94,8 - Ø int. 35 - c/pick-up a 1 cavo (fig. 2)

Per:

- Aprilia** Atlantic 250 (04/06 - carb.)
Scarabeo 250 (04/06 - carb.)
- Derbi** GP1 250 (06/07 - carb.)
- Gilera** Oregon 250 ATV
- Malaguti** Madison RS 250 (04/05)
F12 Phantom Max 250
- Piaggio** Beverly 250 (04/07 - carb.)
X9 250 Evolution (04/07)

Rif. Aprilia/Derbi/Gilera/Piaggio: 58049R (volano) • 58048R/584849 (statore) • 584850 (rotore)

MOTORE PIAGGIO "QUASAR" 125/250/300 4T INIEZIONE (4V - LIQUIDO)



16.8003 • statore 18 poli trifase - c/pick-up a 2 cavi - 350W - Ø est. 94,7 - Ø int. 34,9 - c/connettore marrone

Per:

- Aprilia** 125/300 SR Max ie (11/13)
Atlantic 250 IE (06/09)
Scarabeo 250 IE/Light Euro 3 (06/10)
Sportcity 250 IE/Cube (06/10)
Sport City 300 Cube (08/13)
Scarabeo 300 Light/Special (09/13)
- Derbi** GP1 250 Euro 3/Racing (07/09)
Rambla 250
- Gilera** Nexus 125 IE (08/13)
Nexus 250 Euro 3/SP (06/07)
Nexus 300 (08/13)
- Malaguti** Madison 3 250 (06/>)
- Peugeot** 250 Satelis
250 Geopolis
- Piaggio** Vespa GTS 125 Super (fino a maggio 2010)
Beverly 250/IE Euro 3/Sport (06/07)
Beverly 250 Cruiser/Tourer (07/10)
Carnaby 250
250 X7 (08/10)
250 X-Evo (07/10)
X8 250 (05/07)
MP3 250 (06/10)
Vespa GTV 250 (06/10)
Vespa 250 GTS IE (06/10)
Vespa 250 GT 60 (06/08)
MP3 125 IE (08/09)
MP3 125 Hybrid (09/10)
Beverly 300 Tourer (09/10)
Carnaby 300 Cruiser (09/13)
Vespa 300 GTS Super (08/10)

Rif. Aprilia/Derbi/Gilera/Piaggio: 58070R/58112R/638848
Sostituisce **16.8002**

MOTORE PIAGGIO "QUASAR" 125/300 4T INIEZIONE (4V - LIQUIDO)



16.8005 • statore 18 poli trifase - c/pick-up a 2 cavi - 350W
Ø est. 94,7 - Ø int. 34,9 - c/connettore bianco

Per:

- Aprilia** 300 Atlantic (10/13)
- Piaggio** 125 Vespa GTS Super/Supersport IE (da 06-10/13)
125 X7 Evo IE (09/13)
125 X10 (12/13)
125/300 Beverly RST 4T-4V ie (10/13)
125 MP3 Touring (09-11/>)
125 MP3 Yourban ERL/NRL (11/13)
300 MP3 Yourban ERL/LT (10/15)
300 MP3 Yourban EURO 4 (16/17)
300 MP3 Ibrido/ERL (10/13)
300 MP3 LT/Sport/Touring (10/13)
300 X7 Evo IE (09/10)
300 MP3 IE Mic (10/13)
300 MP3 IE LT (10/13)
300 Vespa GTS IE (12/15)
300 MP3 LT Sport / Business EURO4 (16/17)
300 Vespa GTV IE (10/13)
300 Vespa GTS SuperSport (10/13)
300 Vespa GTS Super (10/13)
300 Vespa GTS IE EURO4 (16/17)
300 Vespa GTV 6 Giorni EURO 4 (17)

Rif. Piaggio: 58202R/58224R

MOTORE PIAGGIO "QUASAR" 350 4T INIEZIONE - EURO3 (4V - LIQUIDO)



16.8009 • statore 18 poli trifase - c/connettore bianco - c/pick-up a 2 cavi

Per:

- Piaggio** Beverly 350 4T-4V Euro 3 ie (11/15)
350 Beverly ST IE ABS (16/17)
X-10 350 4T-4V Euro 3 ie (12/13)

Rif. orig.: 58244R

MOTORE PIAGGIO "MASTER" 400/500 4T



- 16.8520** • volano completo trifase 18 poli - 370W - Ø 117 - cono 23 (fig. 1+2) s/pick-up
- 16.8020** • statore trifase 18 poli - Ø est. 96 - Ø int. 37 (fig. 2) - s/pick-up
- 35.201202** statore Ducati 18 poli trifase - 370W - Ø est. 96 - Ø int. 37 (fig. 2) s/pick-up
- 35.201201** rotore Ducati Ø 117 - cono 23 (fig. 1)

Per:

- Aprilia** Atlantic 400 Sprint
Atlantic 500/Sprint
Scarabeo 400/Light
Scarabeo 500/GT/Light (02/07)
- Gilera** Nexus 500
- Malaguti** Spidermax 500 GT (04/07)
- Piaggio** X9 500
Beverly 400 (06/08)
X8 400
X-Evo 400
Beverly 500/Euro 3 (02/08)

Rif. Aprilia/Gilera/Piaggio: 58080R (statore) • 58040R/584435 (rotore)

MOTORE PIAGGIO "MASTER" 400/500 4T



- 16.8004** • statore 18 poli trifase - 370W - Ø est. 96 - Ø int. 37 - c/pick-up a 2 cavi

Per:

- Aprilia** Scarabeo 500 Light (08/13)
- Gilera** Fuoco 500 (07/13)
- Malaguti** Spidermax RS 500 (08/10)
- Peugeot** Satelis 400/500
Geopolis 400/500
- Piaggio** Beverly 400 Tourer (08/10)
Beverly 500 Cruiser (07/13)
MP3 400 (07/12)
MP3 400 LT (09/12)
MP3 400 Mic (08/12)
500 MP3 LT/RL/Sport/Business (11/13)

Rif. Aprilia/Gilera/Piaggio: 58108R

Rif. Malaguti: 48202400

Rif. Peugeot: 759735

STATORI SCOOTER 50/125/150 4 TEMPI MOTORI CINESI

MOTORE 139 QMA/QMB 50 4T - 8C/AC



- 16.9026** Statore 8 poli c/2 bobine alimentazione - c/pick-up
Ø est. 88 - Ø int. 29 - int. fori 42

Per:

- Benelli • Garelli • Malaguti • Peugeot** Scooter 50 4T
Scooter cinesi vari

MOTORE GY6 125 4T - CARBURATORE - 8C/AC



- 16.9027** Statore 8 poli c/1 bobina alimentazione - c/pick-up
Ø est. 88 - Ø int. 29 - int. fori 42

Per:

- Benelli • Garelli • Keeway • Peugeot** Scooter 125 4T
Scooter cinesi vari

MOTORE GY6 150 4T CARBURATORE - 11C/AC



- 16.9029** Statore 11 poli trifase c/1 bobina alimentazione - c/pick-up a 1 cavo
Ø est. 88,5 - Ø int. 29 - int. fori 42

Per:

- Benelli • Garelli • Keeway** Scooter 150 4T
Scooter cinesi vari

VOLANI E STATORI MOTOCICLI APRILIA - DERBI - CAGIVA - GILERA - HUSQVARNA - MOTO GUZZI

MOTORE CAGIVA 125 2T EURO 2/EURO 3 (IMPIANTO DUCATI)



31.1465 volano completo Ducati 12 poli - trifase - s/pick-up - c/piastra (fig. 1+2)

Di primo equipaggiamento su:

Cagiva Mito 125 EU2/EU3 (06/13)
Mito 125 SP 525 (08/12)
Raptor 125 EU2/EU3 (06/13)

Rif. Cagiva: 8000A6654
Rif. Ducati: 31146520

MOTORE PIAGGIO/DERBI 125 4T INIEZIONE (4V - LC)



16.8058 • statore 12 poli trifase

Per:

Aprilia RS4 125 4T (11/17)
Derbi 125 GPR 4T (09/13)
125 Senda R/SM DRD Racing 4T (09/13)
125 Mulhacen 4T EU 3/Cafè (07/13)
125 Terra 4T EU 3/Adventure (07/13)

Rif. orig.: 640043

MOTORI HUSQVARNA 125 2T (IMPIANTO DUCATI)



31.146531 rotore Ducati (fig. 1)

31.146532 statore Ducati 12 poli trifase - c/piastra - s/pick-up (fig. 2)

Di primo equipaggiamento su:

Husqvarna WRE 125 (07/13)
SM 125 S (07/13)

Rif. Ducati: 31146531 (rotore) • 31146532 (statore)
Rif. orig.: 8000H2263 (statore) • 8000B0495 (rotore) • 8000H2264 (volano completo)

MOTORI PIAGGIO/APRILIA 750/1200 4T V-TWIN INIEZIONE (4V - LC)



16.8007 • statore 18 poli trifase - 450W - Ø est. 118,6 - Ø int. 54 - spess. 31 - c/pick-up a 2 cavi

Per:

Aprilia 750 Shiver (07/16)
750 Shiver GT (09/16)
750 Dorsoduro (08/16)
750 Dorsoduro Factory (10/16)
900 SL Shiver (17)
900 Dorsoduro (17)
1200 Dorsoduro (11/17)

Rif. orig.: 640168

MOTORI HUSQVARNA 250/450/510 4T CARBURATORE EURO 3 (IMPIANTO DUCATI)



31.14602 volano completo Ducati 12 poli monofase Ducati (Ducati 31146020) c/pick-up a 2 cavi

Di primo equipaggiamento su:

Husqvarna TE 250/450/510 Euro 3 (07)
SM 250 R 4T Euro 3 (07/09)
SM 450 R/510 R Euro 3 (07)

Rif. orig.: 8000A8928

MOTORI PIAGGIO/APRILIA 800/850 4T V-TWIN INIEZIONE (4V - LC)



16.8008 • statore 18 poli trifase - 450W - Ø est. 118,6 - Ø int. 54 - spess. 31

Per:

Aprilia 850 Mana (08)
850 Mana GT (09/15)
SRV 850 (12/13)
Gilera GP 800 (08/13)
GP 800 Centenario (09)

Rif. Aprilia/Gilera: 58145R

MOTORI MOTO GUZZI (IMPIANTO DUCATI)

35.0495 alternatore Ducati 14 poli a ponte 350W - 2 cavi c/connettore - rotazione max 14.000 giri - statore Ø 112/77,3 - rotore Ø 76 - spessore 47 mm. - cono Ø 18

Di primo equipaggiamento su:

Moto Guzzi 750 V7 Classic (08/12)
 Brevia 750
 Nevada 750/Club/ie/Classic C (98/13)
 V75/750 PA Polizia (95/>)
 Café 750 V7 Racer (10/13)
 750 V7 Special / Stone (12/13)
 850 T5 Polizia/Carabinieri (94/>)
 940 Bellagio
 California 1000 III Carb./ie/Caren. (alternat. Ducati)
 1000 GT/Quota/Daytona/Strada/V10 Centauro
 1100 California (94/13)
 1100 Quota/Sport
 V11 Sport/Le Mans/Naked/Café

Rif. Ducati: 350493/350494/350495/350496

Rif. Guzzi.: GU37712405 • GU37712411 • GU30712460 (GU29712461/GU30712400)

MOTORI MOTO GUZZI (IMPIANTO SAPRISA)

16.63611 alternatore Saprisa 12V/300W

Per:

Moto Guzzi c/alternatore Saprisa
 V35 Carabinieri/PA (90/01)
 Nevada 350/Club (92/99)
 V35 III (85/87)
 NTX 350 (87/90)
 V50 PA (92/01)
 V65 Florida (86/92)
 V65 Polizia/PA (88/95)
 650 65 GT (87/89)
 NTX 650 (87/90)
 V75 Polizia/PA (92/96)
 Targa 750 (90/92)
 750 SP (90/92)
 Strada 750 (93/95)
 Nevada 750/Club (91/01)
 1000 S (89/94)
 1000 SP III (89/94)
 1000 GT (87/91)
 California 1000 II (83/86)
 California 1000 III Carb./Carenato (87/93)

Rif. orig.: GU28712400

Sostituisce **16.6361**

VOLANI PIAGGIO CICLOMOTORI VESPA - COSA - APE



16.3509 rotore completo c/bobina alimentazione e bobina illuminazione

Per:

Piaggio Ciclomotori con accensione a puntine
Ciao
Bravo
Si

Rif. rotore: 1665425

Rif. bobina: 1218225 • 1874045

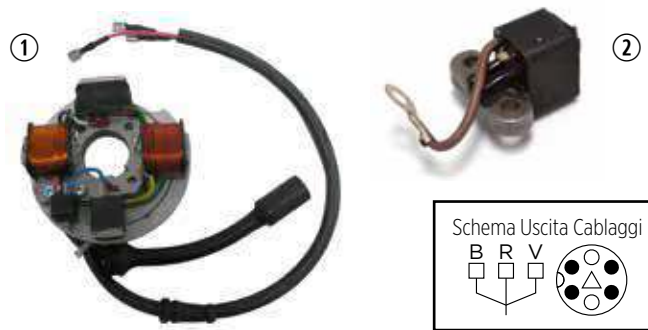

16.41014 statore 4 poli completo c/piastra (fig. 1)

16.962800 pick-up (fig. 2)

Per:

Piaggio 50 Vespa PK s/freccie (V5X1T - s/avv.to elettrico)
50 Vespa PK S (82/86 - V5X2T - c/freccie - s/avv.to elettrico)
50 Vespa PK SS (83/86 - V5S1T - c/freccie - s/avv.to elettrico)

Rif. orig.: 199491 • 216529 • 199481

Sostituisce **16.410204**



16.4152 statore elettronico 4 poli, 2 bobine c/pick-up

Per:

Piaggio 50 Boss
50 Bravo EVL/3 (87/92)
50 SI/FL2/Mix (79/99 - s/freccie - c/variatore)
50 Superbravo
50 Superbravo 3

Rif. orig.: 218584



16.3010 statore 4 poli c/piastra (fig. 1)

16.962800 pick-up (fig. 2)

Di primo equipaggiamento su:

Piaggio 50 Vespa PK XL (85/88 - s/avv.)
50 Vespa PK XL Rush (88/89 s/avv.)
50 Vespa PK N (89/90 - s/avv.)

Rif. orig.: 234321



16.3032 statore elettronico 4 poli, 4 bobine - c/pick-up (fig. 1)

16.962800 pick-up (fig. 2)

Per:

Piaggio ciclomotori 50 Si/Bravo/Grillo/Boss c/freccie
Ciao Mix/Teen/Euro 1/Euro 2 (96/04)

Rif. orig.: 293814



16.436304 statore Ducati 6 poli c/piastra (fig. 1)

16.740109 pick-up (fig. 2)

Di primo equipaggiamento su:

Piaggio Vespa PK 50 S (82/85 - c/freccie - c/avviamento elettrico)

Rif. orig.: 199493



16.436004 statore 6 poli c/piastra (fig. 1)
16.740109 pick-up (fig. 2)

Per:

- Piaggio** Vespa PK 50 XL/XL Rush/N/FL (85/90 - c/avv.to elettrico)
 Vespa PK 125 XL/FL (86/90 - c/avviamento elettrico)
 Ape TMP 50 (85/89 - c/avviamento elettrico)
 Vespa PK 125 S (82/85 - c/freccie - s/avviamento elettrico)
 PK 125 XL (86/89)
 PK 125 FL (89/90)

Rif. orig.: 199495

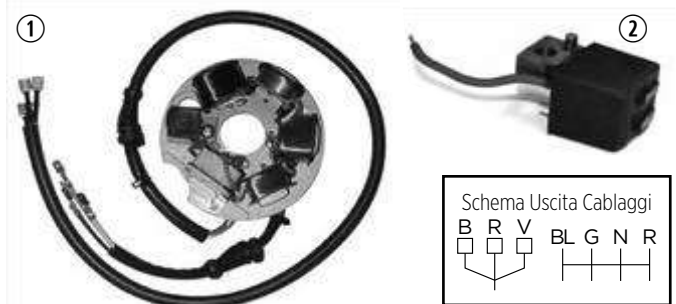

31.7310 statore Ducati 6 poli - c/piastra (fig. 1)
16.3009 statore adattabile 6 poli c/piastra (fig. 1)
16.740109 pick-up (fig. 2)

Di primo equipaggiamento su:

- Piaggio** Vespa 125 Primavera ET3 elettronica

Rif. orig.: 186974

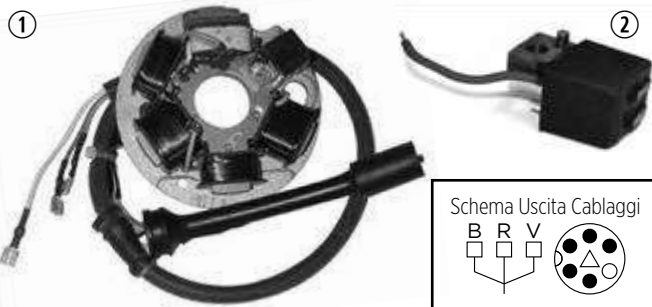

16.436204 statore 6 poli c/piastra (fig. 1)
16.740109 pick-up (fig. 2)

Per:

- Piaggio** Vespa PK 50 FL2 HP (91/97)
 Vespa PK 125 S (82/85 - c/freccie - c/avviamento elettrico)
 Ape P50 (84/85 - c/avv.to el.)
 Ape 50 FL/FL2 (89/95)
 Ape 50 FL3 Europa (96/99)
 Ape 50 Mix (RST) Base/Top (99/09)
 Ape 50 Mix Euro 2 Top (fino a 08-11)

Rif. orig.: 199500 • 497651 • 2330435

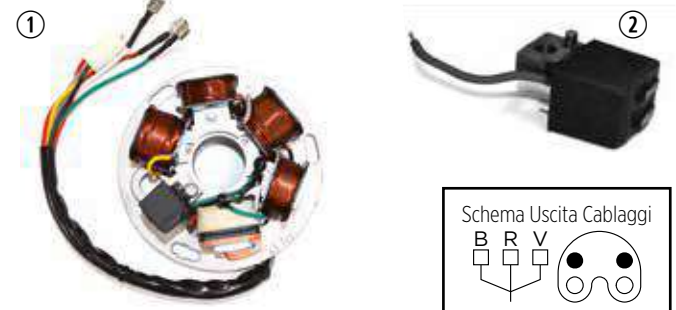

16.4371 statore 6 poli c/piastra (fig. 1)
16.43717 statore 6 poli adattabile (fig. 1)
16.740109 pick-up (fig. 2)

Per:

- Piaggio** Vespa PX 125/150/200 E/PX
 Arcobaleno (81/97 - s/avv.to elettrico)
 Vespa PX-E 125/150/200 (98/01)
 Vespa PX 125 Euro 2/30 anni (01/08)
 Vespa PX 125/150 (11)
 Vespa PX 200 (98/06)
 Cosa CL/CLX 125/150/200
 Cosa 2 125/150/200

Rif. orig.: 217866 • 497652 • 233871



16.3025 statore 6 poli c/piastra (fig. 1)
16.740109 pick-up (fig. 2)

Per:

- Piaggio** Ape 50 FL3 Nettezza urbana (96/99)
 Ape 50 FL3 Cross RST (99/>)
 Ape 50 FL3 Cross (96/99)
 Ape 50 Cross RST/Cross Country (99/10)

Rif. orig.: 256309



16.4370 statore 6 poli c/piastra (fig. 1)
16.740109 pick-up (fig. 2)

Di primo equipaggiamento su:

- Piaggio** Vespa PX 125/150 E (81/> - elettronica c/batteria)
 Vespa PX 125/150/200/E/Arcobaleno (81/97 - avv.to elettrico)
 Vespa P 200 E (79/83 - c/batteria)

Rif. orig.: 217983



16.3008 statore elettronico 6 poli c/piastra (fig. 1)
16.740109 pick-up

Per:

Piaggio Vespa PX T5 125 (c/s/avv.to elettrico)

Rif. orig.: 232172



16.8070 statore 12 poli monofase c/pick-up interno - c/piastra

Per:

Piaggio 50 Ape Mix/Top/VF/VPC/VPL Euro2 (11/17 da 08-2011/>)

Rif. orig.: 642205

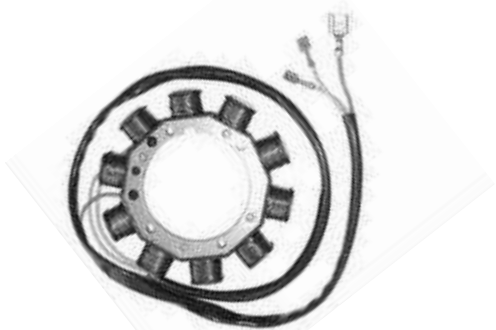

16.3040 statore 10 poli controfase - 3 cavi - faston differenziati

Per:

Piaggio Ape Car Diesel/Max Diesel (86/96)
Ape TMP 703 Diesel (87/04)

Rif. orig.: 2318765 (231876)

STATORI E VOLANI MOTO HONDA - KAWASAKI - SUZUKI - YAMAHA



16.1602 • statore giapponese 18 poli trifase - c/pick-up 2 cavi - 104x42x20

Per:

Yamaha FZS 600 Fazer (98/01)

Rif. orig.: 4YR-81410-01



16.1608 • statore giapponese 18 poli trifase - s/pick-up - 115x42x30

Per:

Yamaha 1000 YZF-R1/SP (02/03)

Rif. orig.: 5PW-81410-01



16.1603 • statore giapponese 18 poli trifase - s/pick-up - 104x42x25

Per:

Yamaha 1000 YZF-R1 (98/01)

Rif. orig.: 4XV-81410-01



16.1609 • statore giapponese 18 poli trifase - c/pick-up 2 cavi - 130x58x25

Per:

Yamaha XVS 1100 DragStar (99/02)
XVS 1100 A Dragstar Classic (00/02)
BT 1100 Bulldog

Rif. orig.: 5EL-81410-01 • 5JN-81410-00/01



16.1604 • statore giapponese 18 poli trifase - s/pick-up - 104x42x25

Per:

Yamaha 600 YZF-R6 (99/02)

Rif. orig.: 5EB-81410-00



16.1610 • statore giapponese 12 poli trifase - s/pick-up

Per:

Yamaha 800 FZ8 N/S (11/14)
1000 YZF-R1 (04/08)
1000 FZ1/N/Fazer (06/13)

Rif. orig.: 2D1-81410-01



16.1607 • statore giapponese 18 poli trifase - s/pick-up - 115x54x25

Per:

Yamaha XVS 650 DragStar (97/02)
XVS 650 A DragStar Classic (98/02)

Rif. orig.: 4VR-81410-00



16.1612 • Statore giapponese 18 poli - trifase

Per:

Yamaha 535 XV SE Virago (87/88)
535 XV Virago (89/98)
535 XV DX Virago (99/02)

Rif. orig.: 2GV-81410-20



16.1613 Statore giapponese 18 poli - trifase - s/pickup

Per:

Yamaha 750 XV Virago (88/00)
1000 XV Virago/SE (88)
1100 XV Virago (86/99)

Rif. orig.: 4PP-81410-00



16.1618 • statore giapponese 18 poli trifase - c/pick-up a 2 cavi - 104x42x20

Per:

Yamaha FZS 600/Fazer (02/03 - 5RT)

Rif. orig.: 5RT-81410-00



16.1614 Statore giapponese 18 poli - trifase - c/pick-up

Per:

Yamaha 600 YZF-R Thundercat (96/02)
600 FZR-R (94/95)

Rif. orig.: 4TV-81410-01



16.1620 • statore giapponese 18 poli - trifase - c/pick-up

Per:

Yamaha XVS 650 A Dragstar Classic (04/07)

Rif. orig.: 5SC-81410-01



16.1615 Statore giapponese 18 poli - trifase - s/pickup

Per:

Yamaha XV 1600 Wildstar (96/02)

Rif. orig.: 4WM-81410-01



16.1700 • statore giapponese 15 poli trifase - s/pick-up

Per:

Suzuki GSX-R 1000 (05/08)

Rif. orig.: 31401-41G10-000



16.1617 • statore giapponese 18 poli trifase - s/pick-up - 104x42x25

Per:

Yamaha FZS 1000 Fazer (01/05)

Rif. orig.: 5VL-81410-00



16.1701 • statore giapponese 18 poli trifase - s/pickup

Per:

Suzuki 600 GSX-R (01/03)
750 GSX-R (00/03)

Rif. orig.: 31401-35F10



16.1703 • statore giapponese 18 poli trifase - c/pickup

Per:

Suzuki 650 LS Savage (86/97)

Rif. orig.: 32101-24B02



16.1704 • statore giapponese 18 poli - trifase - c/pick-up

Per:

Suzuki 400 DRZ E (00/07)
400 DRZ S (00/15)
400 DRZ SM (05/15)

Rif. orig.: 32101-29F00



16.1705 • statore giapponese 18 poli - trifase - c/pick-up

Per:

Suzuki 400 DRZ (00/03)

Rif. orig.: 32101-29F10



16.1706 • statore giapponese 18 poli - trifase - c/pick-up

Per:

Suzuki 650 DR SE (96/14)

Rif. orig.: 32101-32E00



16.1800 • statore giapponese 18 poli trifase - s/pickup

Per:

Kawasaki 600 ZX-6RR (03/04)
636 ZX-6R (03/04)
750 Z (05/06)
750 Z S (05/06)
1000 Z (03/05)

Rif. orig.: 21003-0001



16.1801 • statore giapponese 18 poli trifase - s/pickup

Per:

Kawasaki 600 ZX-6RR (05/06)
636 ZX-6R (05/06)

Rif. orig.: 21003-0023



16.1802 • statore giapponese 18 poli trifase - s/pickup

Per:

Kawasaki 650 ER-6N (06/11)
650 ER-6N ABS (06/11)
650 ER-6F (06/11)
650 ER-6F ABS (06/11)
650 KLE Versys (07/14)
650 KLE Versys ABS (07/14)

Rif. orig.: 21003-0042



16.1803 • statore giapponese 18 poli trifase - s/pickup

Per:

- Kawasaki** 750 Z (07/12)
- 750 Z ABS (07/12)
- 750 Z R (11/12)
- 750 Z R ABS (11/12)
- 800 Z (13/15)
- 800 Z ABS (13/15)
- 800 Z E (13/15)
- 800 Z E ABS (13/15)
- 1000 Z (07/09)
- 1000 Z ABS (07/09)

Rif. orig.: 21003-0046



16.1806 • statore giapponese 15 poli trifase - s/pickup

Per:

- Kawasaki** 1000 ZX-10R (08/10)

Rif. orig.: 21003-0072



16.1807 • statore giapponese 18 poli trifase - s/pickup

Per:

- Kawasaki** 600 ZZR (90/06)
- 600 ZX-6R (F1/F3 - 95/97)

Rif. orig.: 21003-1368



16.1804 • statore giapponese 15 poli trifase - s/pickup

Per:

- Kawasaki** 900 VN Classic (06/14)
- 900 VN Custom (07/11)
- 900 VN Vulcan Classic (15)
- 900 VN Vulcan Custom (12/15)

Rif. orig.: 21003-0053



16.1808 • statore giapponese 18 poli trifase - s/pickup

Per:

- Kawasaki** VN 800 Vulcan (95/98)
- VN 800 Vulcan Classic (96/06)
- VN 800 Vulcan Drifter (99/01)

Rif. orig.: 21003-1383



16.1805 • statore giapponese 15 poli trifase - s/pickup

Per:

- Kawasaki** 1000 ZX-10R (06/07)

Rif. orig.: 21003-0054



16.3039 statore 18 poli trifase - s/pickup

Per:

- Suzuki** 600 GSX-R (12/15)
- 750 GSX-R (12/15)

Rif. orig.: 31401-01H20



16.3042 statore 18 poli trifase - s/pick-up - 115x54x35

Per:

Honda VF 750 S Sabre (82/85)
VF 750 C Magna/Shadow (82/92)
VF 750 F Interceptor (83/85)
VF 1000 F Interceptor (84/85)
VF 1000 R (85/86)
VFR 750 F (86/87)
VF 1100 C MagnaShadow (83/86)
VF 1100 S Sabre (84/85)

Suzuki TL 1000 R/S

Rif. Honda: 31120-MBO-415 • 31120-MB1-024 • 31120-MN0-004 • 31120-MB2-691 • 31120-MB6-014 • 31120-ML7-692/921

Rif. Suzuki: 32101-02F00



16.3045 statore a rotore interno

Per:

Kawasaki 900 Z/KZ LTD (B1 - 76)
900 Z/KZ (A4/A5 - 76/77)
1000 Z/KZ (A1/A2 - 77/78)
1000 KZ TD (B1/B2 - 77/78)
1000 KZ Z1R (D1 - 77)
1000 Z/KZ Police (78 - C1/C1A)

Rif. orig.: 21076-023



16.3043 statore 18 poli trifase - s/pick-up - 104,5x38x20

Per:

Kawasaki 1000 KZ (J1/J3 - 81/83)
1000 KZ LTD (K1/K2 - 81/82)
1000 KZ CSR (M1/M2 - 81/82)
1000 Z/KZ R Eddie Lawson Replica (R1/R2 - 82/83)
1100 GPZ (KZ1100 B1/B2 - 81/82)
1100 GPZ (ZX1100 A1/A3 - 83/85)
1100 KZ Spectre (D1/D2 - 82/83)
1100 KZ Shaft (A1/A3 - 81/83)
1100 KZ LTD Shaft (L1 - 83)
1100 ZN LTD Shaft (B1/B2 - 84/85)

Rif. orig.: 21003-1040



16.3046 statore 18 poli trifase - s/pick-up - 103x38x20

Per:

Kawasaki GPZ 400 (83 - KZ400M1)
GPZ 400 (85/87 - ZX400 A3/A5)
GPZ 400 (91/94 - ZX 400 C4/C5)
Z 400 F (83/84 - ZR400 A1/B1)
Z 400 F II (85/87 - ZX400 C2/C3)
500 ZKZ (81/83 - B1/B4)
Z 500 F (83 - ZR500 A1)
550 GPZ (KZ550 D1 - 81)
550 GPZ (KZ550 H1/H2 - 82/83)
550 GPZ (ZX550 A1/A6 - 84/89)
550 GT (Z 550 G1/G9 - 83/93)
550 Z/KZ LTD Shaft (KZ550 M1/F2 - 83/84)
550 Z/KZ Spectre (KZ550 F1 - 83)
550 Z/KZ (KZ550 A2 - 81)
550 Z/KZ (KZ550 A3/A4 - 82/83)
550 Z/KZ LTD (KZ550 C2 - 81)
550 Z/KZ LTD (KZ550 C3/C4 - 82/83)
550 Z F (ZR550 A1/A2 - 83/84)
550 ZR Zephyr (ZR550 B1/B5 - 90/95)
550 ZR Zephyr (ZR550 B7/B9 - 96/98)

Rif. orig.: 21003-1256



16.3044 statore 18 poli trifase - s/pick-up - 115x54x16

Per:

Kawasaki VN 1500 Vulcan 88 SE (87/90 - B1/B4)
VN 1500 Vulcan 88 (87/95 - A1/A9)
VN 1500 Vulcan (96/99 - A10/A13)
VN 1500 Vulcan L (96/97 - C3/C4)
VN 1500 Vulcan Classic (96/98 - D1/D2-E1)

Rif. orig.: 21003-1164 • 21003-1301



16.3047 statore 18 poli trifase - s/pick-up - 93x35x20

Per:

Suzuki GSX 250/E/S (82/83)
 GSX 400 (82/86)
 GS 450 S (82)
 GS 450 E (82/88)
 GS 500 E (81/83)
 GS 500 E (89/00)
 GS 500 (01/02)
 GS 550 L (80/82)
 GS 550 M (81/82)
 GS 550 (X/EX - 81)
 GS 550 (LT/LX - 80/81)
 GS 550 (MX/MZ - 81/82)
 GS 550 T (82)
 GS 500 (01/07)
 GS 650 G/GL/M (81/83)
 GS 650 E (81/82)
 GS 750 E (80/82)
 GS 750 L (80/81)
 GS 750 S (83)
 GS 750 T (82/83)
 GSX 750 E (80/81)
 GSX 750 S (82/83)
 GS 850 G/GL (80/86)
 GS 1000 S (82)
 GSX 1000 S (82)
 GS 1100 S (83)

Kawasaki 650 Z/KZ CSR (H1/H3 - 81/83)
 750 Z/KZ LTD Shaft (F1 - 83)
 750 Z/KZ Spectre (N1/N2 - 82/83)
 750 Z/KZ (E1/E3 - 80/82)
 750 Z/KZ (L3/L4 - 83/84)
 750 Z/KZ LTD (H1/H4 - 80/83)
 750 GPZ (KZ750R1 - 82)
 750 GPZ Unitrack (ZX 750 A1/A5 - 83/87)
 750 GT (Z 750 P3/P7 - 84/92)
 750 ZR-7/ZR-7S (ZR750 F/H - 99/03)

Yamaha XJ 600 S Diversion (92/95)
 XJ 600 N (95)

Rif. Suzuki: 31401-47030 • 31401-01D10 • 31401-45120 (31401-45110/111) • 31401-49531

Rif. Kawasaki: 21003-1083 • 21003-1349

Rif. Yamaha: 4BR-81410-00



16.3048 statore 18 poli trifase - s/pick-up - 95x35x16

Per:

Suzuki GS 250 (80/81)
 GS 250 (96/99)
 GSX 400 (80/81)
 GSX 400 E/S/L (96/99)
 GS 425 E/L (79)
 GS 425 (92)
 GS 450/L (80/83)
 GS 450 T (81/83)
 GS 550 E (77/80)
 GS 550 (96)
 GS 550 L (79)
 GS 750 (77/79 - 8 valvole)

Rif. orig.: 31401-45030



16.3049 statore 18 poli trifase - s/pick-up - 103x38x20

Per:

Suzuki GSX 500 E (84/85)
 GS 550 ES/EF (83/86)
 GS 550 L (83/86)
 GSX 550 E (83/87)
 GSX 600 E (87)
 GS 750 E/ES (83/85)
 GSX 750 S (84)
 GSX 750 E/EF/ES (83/86)
 XN85-D 850 (83)
 GS 1000 (78/81)
 GS 1000 S (79/80)
 GS 1000 L (79)
 GS 1000 E (80)
 GS 1000 G/GL (80/81)
 GS 1100 (82/86)
 GS 1100 E/ES (80/83)
 GS 1100 LT (80)
 GS 1100 G/GL (82/83)
 GS 1100 GK (82/83)/GKE (84)
 GSX 1100 E/ES/EF/EG (84/86)
 GS 1150 E/ES/EF/EG (84/86)

Rif. orig.: 31401-43400 • 31401-09310 • 31401-08A00 • 31401-09300 • 31401-00A00



16.3051 statore 18 poli trifase - s/pick-up - 115x54x20

Da adattare (utilizzare connettore e gommino del vecchio statore) su:

Honda VT 500 C/E
 VT 600 C Shadow
 XL 600 V Transalp
 XRV 650 Africa Twin
 XRV 750 Africa Twin (90/92 - MV1)

Per:

Suzuki VS GL 600 Intruder (95)
 VS GL 750 Intruder (85/91)
 VS GL/GLV 800 Intruder (92/95)

Yamaha XZ 550
 XTZ 660 Ténéré (91/96)
 660 SZR

Rif. Suzuki: 32101-38A10

Rif. Yamaha: 3YF-81410-01



16.3052 statore trifase 18 poli - s/pick-up 112x54x34

Per:

Yamaha XV 750 Virago/Midnight (81/83)
 XV 750 Virago (92/96)
 XV 920 R/Virago (81/83)
 XV 1000 TR1/Virago/Midnight Special (81/83)
 XV 750 Virago (84/85)
 XV 1000 Virago (84/85)
 XV 1000 SE Virago (86/89)
 XV 1100 Virago (89/97)

Rif. orig.: 4X7-81410-20 • 42X-81410-20 • 1RM-81410-20 • 4PP81410-00



16.3083 statore 12 poli c/pick-up

Per:

Honda 450 CRF-X (05/16)

Rif. orig.: 31120MEY672



16.35991 volano completo Denso 18 poli trifase s/pick-up

Di primo equipaggiamento su:

Honda CB 600 F Hornet (07/12)
 CBR 600 F (11/12)
 CBF 600 N/S/ABS (08/12)

Rif. orig. (statore): 31120-MFG-D01

Rif. orig. (rotore): 31110-MFG-D01

Rif. Denso (volano): LMX80 037000-6995



16.9010 statore 18 poli trifase - s/pickup

Per:

Honda CBR 900RR Fireblade (00/01)

Rif. orig.: 31120-MCJ-003



16.9011 statore 18 poli trifase - s/pickup

Per:

Honda CBR 900R Fireblade (96/99)

Rif. orig.: 31120-MAS-004



16.9012 statore 18 poli trifase - s/pickup

Per:

Honda CBR 1000RR Fireblade (04/07)

Rif. orig.: 31120-MEL-305 • 31120-MEL-D22



16.9013 statore 18 poli trifase - s/pickup

Per:

Honda VFR 800FI (98/01)

Rif. orig.: 31120-MGB-003 • 31120-MGB-D01



16.9017 statore 18 poli trifase - s/pickup

Per:

Honda XL 600V (89/90)
VF 750C (85/88)
VFR 750F (86/89)
VF 1000F (84)
VF 1000R (84/86)

Rif. orig.: 31120-ML7-691 • 31120-MB6-008



16.9014 statore 18 poli trifase - s/pickup

Per:

Honda CBR 1100XX SuperBlackBird (01/03)

Rif. orig.: 31120-MAT-E01



16.9018 statore 18 poli trifase - s/pickup

Per:

Honda CBR 600RR (07/12)

Rif. orig.: 31120-MFJ-D01



16.9015 statore 18 poli trifase - s/pickup

Per:

Honda CBR 900RR Fireblade (93/95)

Rif. orig.: 31120-MWO-004



16.9083 statore 18 poli - trifase - s/pick-up - s/pickup

Per:

Suzuki GSXR 600 (06/11)

Rif. orig.: 31401-01H00



16.9016 statore 18 poli trifase - s/pickup

Per:

Honda VRF 800 V-Tec (02/09)

Rif. orig.: 31120-MCW-D01



17.4501 statore trifase 18 poli - c/pick-up a 2 cavi - 103x42x20

Per:

Keeway 250 Cruiser
250 Land Cruiser
250 Supershadow
Yamaha Virago XV 125 (97/00)
Virago XV 250 (89/99)

Rif. Denso: LMZ65

Rif. Keeway: 299035040000

Rif. Yamaha: 3DM-81410-00



17.4502 statore monofase 12 poli - c/pick-up a 2 cavi

Per:

Malaguti 125 X3M Enduro (mod. Brasile - 08)

Yamaha XT 125 R/X (02/06)

Rif. Malaguti: 78203600

Rif. Yamaha: 3D6-H1410-00



17.4503 statore 8 poli monofase/CC c/pick-up

Per:

Yamaha 125 YBR (05/06)

125 XT R Enduro (07/08)

125 XT X Motard (07/08)

Malaguti 125 X3M Enduro (07/08)

125 X3M Motard (07/08)

Rif. Yamaha: 3D9-H1410-01

Rif. Malaguti: 78203400



17.4510 statore trifase 18 poli - c/pick-up a 2 cavi - 93x34,6x16

Per:

Suzuki 125 Marauder

Rif. orig.: 32101-12F00/30

STATORI QUAD - ATV YAMAHA



16.1630 • statore giapponese trifase 18 poli - c/pick-up

Per:

Yamaha ATV 400 Kodiak 2WD/4WE (03/06)
450 Kodiak 4WD (03/06)
400 Grizzly 4WD (07/08)
450 Grizzly 4WD (04/14)
450 Wolverine 4WD (06/10)

Rif. orig.: 5ND-81410-00



16.1631 • statore giapponese trifase 18 poli - c/pick-up

Per:

Yamaha ATV 350 Warrior (02/12)
350 Raptor/SE (04/13)

Rif. orig.: 5NF-81410-00



16.1632 • statore giapponese trifase 18 poli - c/pick-up

Per:

Yamaha ATV 350 Bruin Auto 2WD/4WD (04)
350 Bruin 2WD/4WD (05/06)
350 Grizzly 2WD/4WD (07/14)
350 Grizzly IRS (07/09)
350 Wolverine 2WD (06/09)

Rif. orig.: 5UH-81410-00



16.3034 • statore trifase 15 poli - c/bobina alimentazione - c/pick-up a 2 cavi

Per:

Yamaha ATV 350 YFM Bigbear (96/99)
350 YFM Wolverine/4WD (95/01)
400 YFM Kodiak (99)

Rif. orig.: 4KB-85510-12

VOLANI HARLEY DAVIDSON



16.8515 • volano completo monofase 12 poli 380W/32A

Per:

Harley Davidson 1314 FLHR Road King (96)
1340 FLHS Electra Glide Sport (89/93)
1314 FLHT Electra Glide Standard (95/96)
1314 FLHTC Electra Glide Classic (89/96)
1340 FLHTCU Electra Glide Ultra Classic (90/96)
1340 FLST Heritage Softail (89/90)
1340 FLSTC Heritage Softail Classic (89/99)
1314 FLSTF Softail Fat Boy (89/99)
1340 FLSTN Heritage Softail Nostalgia (93/95)
1340 FLSTN Heritage Softail Special (94/96)
1340 FLSTS Heritage Softail Springer (97/99)
1314 FLTC Tour Glide Classic (90/91)
1340 FLTCU Tour Glide Ultra Classic (89/95)
1340 FXD Dyna Super glide (95/98)
1340 FXDS Dyna Convertible (96/98)
1314 FXDS Dyna Low Rider Convertible (94/95)
1340 FXDB Dyna Sturgis (91)/Daytona (92)
1340 FXDC Dyna Glide Custom (92)
1314 FXDL Dyna Low Rider (93/98)
1314 FXDWG Dyna Wide Glide (93/98)
1340 FXLR Low Rider Custom (90/94)
1314 FXR Super Glide (89/94)
1340 FXRS Low Rider/Convertible (89/94)
1340 FXRS-SP Low Rider Sport (89/93)
1340 FXRT Sport Glide (90/92)
1314 FXST Softail (89/90)
1340 FXSTC Softail Custom (89)
1314 FXSTB Softail Night Train (99)
1314 FXSTS Softail Springer (89/99)
1340 FXSTSB Softail Springer Bad Boy (95/97)
1314 FXST Softail Standard (99)

Rif. orig. statore: 29970-88C

Rif. orig. rotore: 29957-81B

ALTERNATORI MOTO



16.6702 alternatore 12V/35A

Per:

Kawasaki ZG 1200 (86/91)
ZR 1100 Zephyr (92/95)

Rif. Kawasaki: 21001-1083/1068 • 21001-1121/1123

Rif. Mitsubishi: A7T20199



17.6715 alternatore 12V/60A

Per:

BMW 850 R R (02/09)
850 R RT (02/07)
1150 R RT (00/08)
1200 R C (03/05)
1200 R Montauk (03/05)
1200 R C Independent (03/05)
1200 R CL Confortline (02/05)

Rif. orig.: 12312306955

Equivalente **Bosch** 0123105003 • 0123214003



16.6710 alternatore 12V/40A

Per:

Honda GL 1500 Gold Wing (89/90)
GL 1500 A Gold Wing (91/00)
GL 1500 SE Gold Wing (91/00)

Rif. Honda: 31100-MT2-005/15

Rif. Hitachi: LR140-708/A/B/C



17.6718 alternatore 12V/50A

Per:

BMW 750 K75 (83/96)
750 K75C (85/95)
750 K75RT (85/96)
750 K75S (85/97)
1000 K100 (82/90)
1000 K100/2 (82/90)
1000 K100LT (83/92)
1000 K100RS (83/93)
1000 K100RT (83/92)
1000 K1 (83/95)
1100 K LT (90/00)
1100 K RS (92/98)
850 R GS (96/02)
850 R R (94/01)
850 R RT (96/01)
850 R C (99/>)
1100 R GS (94/>)
1100 R R (94/>)
1100 R S (98/>)
1100 R RS (93/>)
1100 R RT (96/>)
1150 R GS (00/>)
1150 R GS Adventure (01/>)
1150 R RS (01/>)
1150 R R (01/>)
1150 R R Rockster (01/>)
1200 R C (97/02)
1200 R C Independent (00/02)

Rif. orig.: 12312305316 • 12311459005/651 • 12312306020

Equivalente **Bosch** 0123105001 • 0986040420

Sostituisce **Bosch:** 9 120 333 320 • 0 120 339 456



16.6712 alternatore 12V/75A

Per:

Honda GL 1800 A Gold Wing (01/04)

Rif. Honda: 31100-MCA-003/700

Rif. Mitsubishi: A5TA7599/ZC • A005TA7599/ZC

ALTERNATORI E STATORI PER MOTORI AGRICOLO/INDUSTRIALI - MINIVETTURE - UTILITY



35.0307 alternatore Ducati a magneti permanenti 14 poli - 180W - a rotore interno in controfase - 3 cavi regolazione 12V - rot. max 12.000 statore Ø est. 112 spessore ferro 12,5 - rotore Ø 76 spessore 20 - cono 20

Di primo equipaggiamento su:

Lombardini/

Slanzi motori LDA 672/673/674/832/833/834 (82/>)

5LD

8LD

11LD

KHD/Deutz motori FIL 208/210

Ducati 750 GT/Sport/SS (71/74)

750 S/SS/Desmo (</75)

860 GT (</05-75)

Ruggerini motori SP420

SP428

Adattabile su:

kit impianto luce per moto cross **HM**

Honda

Kawasaki

Suzuki

Yamaha

Rif. Lombardini/Ruggerini/Slanzi: 1157.158 • 1157.039 • 904.1157.01 • 1305.46400

Rif. KHD/Deutz: 04191226KZ

Rif. Ducati Meccanica: 075545400

Rif. Ducati Energia: 350307

Sost. **Ducati** art. **35.0101 • 35.0103 • 35.0303 • 35.0306 • 35.0308 • 35.0313**

Intercambiabile **Saprisa 16.6321** solo per motori industriali



16.6321 alternatore Saprisa a magneti permanenti 10 poli - 16A - a rotore interno in controfase - 3 cavi regolazione 12V - rot. max 10.000 statore Ø est. 112 - spessore ferro 12,5 - rotore Ø 76 - spessore 20 cono 20

Di primo equipaggiamento su:

Lombardini/

Slanzi motori LDA 672/673/674/832/833/834 (82/>)

5LD

8LD

11LD

KHD/Deutz motori FIL 208/210

Ruggerini motori SP420

SP428

Rif. Lombardini/Ruggerini/Slanzi: 1157.158 • 1157.039 • 1157.01 • 1305.46400

Rif. KHD/Deutz: 04191226KZ

Rif. Saprisa: 3325

Intercambiabile **Ducati 35.0307** solo per motori industriali



16.6381 alternatore Saprisa a magneti permanenti 10 poli - 30A - a rotore interno in controfase - 3 cavi regolazione 12V - rot. max 10.000 statore Ø est. 112 - spessore ferro 29 - rotore Ø 76 - spessore 33 - cono 20

Di primo equipaggiamento su:

Lombardini/

Slanzi motori LDA 672/673/674

LDA L20/904/914

5LD

8LD

11LD

KHD/Deutz motori FIL 208/210

Ruggerini motori MD 300/301

MD 350/351

MD 358

SP420/428

Rif. Lombardini/Slanzi: 1157.159 • 904.1157.019 • 1157.014.2830 • ED0011571590

Rif. KHD/Deutz: 04191199KZ

Rif. Saprisa: 3385

Sostituisce **Ducati** art. **35.0453 • 35.0451 • 35.0251**



16.6224 alternatore Saprisa a magneti permanenti - 10 poli - 21A - c/piastra - monofase a ponte - 2 cavi regolazione 12V - statore Ø int. 65 - Ø est. 120 - rotore Ø est. 160 - spessore 29

Di primo equipaggiamento su:

Lombardini motori 6LD 260/325/326/360/400/401/435

9LD 561-2/625-2/626-2

12LD 435-2/475-2/477-2

Focs LDW 502/602/1204 (20A)

Superfocs LDW 702/1003/1404 (20A)

Slanzi motori

Ruggerini motori RD 180/181

RD 200/201

RD 210/211

RD 218

Adattabile su:

Hatz motori 2 G 30.16/2 G 40.11 (05-93/>)

2 G 40.16 (07-02/>)

2 G 40.17 (11-03/>)

2 G 40.18 (10-04/>)

2 G 40.19 (06-05/>)

Rif. Lombardini: 1157.041/105/167

Rif. Ruggerini: 01428 • 01421 • 01441

Rif. Slanzi: 491567 • 400.1157.105

Rif. Saprisa: 3222/3224/3226

Rif. Hatz: 50292810

Sostituisce **Ducati** art. **35.5402 • 35.5406 • 35.5452**



- 35.5439** alternatore Ducati a magneti permanenti - 10 poli - 220W - c/piastra - in controfase - 3 cavi regolazione - statore Ø int. 65 - Ø est. 120 - rotore Ø est. 160 - spessore 29
- 16.6264** alternatore Saprisa a magneti permanenti - 10 poli - 16A - c/piastra - in controfase - 3 cavi regolazione 12V - statore Ø int. 65 - Ø est. 120 - rotore Ø est. 160 - spessore 29

Di primo equipaggiamento su:

- Lombardini** motori LDA 450/451/510/520/530/532/533
LDA 710/720
LDA 75/91/96/97/100/820
LA/LAP 400/490
LDA 672/673/674/832/833/834
3LD 45/510/511
4LD 640/705/820
6LD 260/325/326/360/400/401/435
7LD 600-2/665-2/740-2
9LD 561-2/625-2/626-2
10LD 360-2/400-2
12LD 435-2/475-2
Focs LDW 502/602/1204 (20A)
Superfocs LDW 702/1003/1404 (20A)
- Slanzi** motori DVA 460/515/700/740/790/920/1030
- Ruggerini** motori RD/P (76/>)
RD 220/240
RD 270/278
RD 290
RF 80/81
RF 90/91
RF 120/121
RF 140
LA 400/490
- Intermotor** motori
- Acme** motori
- VM** motori

Rif. Lombardini/Intermotor: 283.1156.090 • 1157.153/154 • 3052.1156.090
Rif. Ruggerini: 01409 • 01424 • 01446
Rif. Acme/Slanzi: 4001157.103 • 491562 • 014130
Rif. Ducati: 355439
Rif. Saprisa: 3264/3263/3265
Sostituisce **Ducati** art. **35.5449 • 35.5450 • 35.5431 • 35.5432**



- 16.5246** statore Saprisa 12 poli - 12A/24A - in controfase - 3 cavi regolazione 12V - Ø int. 92 - Ø est. 151

Di primo equipaggiamento su:

- Lombardini** motori 15 LD 225
15 LD 315
15 LD 350
15 LD 400
15 LD 440
Focs LDW 502/602
- Ruggerini** motori RY50
RY70
RY75
RY103
RY110

Rif. Lombardini: 8565.078
Rif. Ruggerini: 0085650780

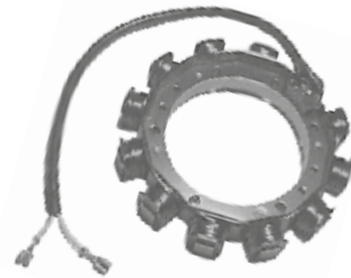

- 16.5247** statore Saprisa 12 poli - 18A/24A/30A - monofase a ponte - 2 cavi regolazione 12V - Ø int. 92 - Ø est. 151

Di primo equipaggiamento su:

- Lombardini** motori 15 LD 225
15 LD 315
15 LD 350
15 LD 400
15 LD 440
LGW 532/627 (30A)
Focs LDW 502/602/1204 (30A)
Superfocs LDW 702/1003/1404 (30A)
- Bellier** 500 Divane
500 VX (mot. Lombardini 30A)
- Chatenet** 500 Stella 214
500 Media
500 Barooder
- Microcar** Lyra 500 Diesel
Virgo I/II
- Piaggio/Ligier** 500 162 Ambra (15 LD 315 - monocil. - 98/00)
500 162 Ambra Y GL/GLS (bicil. - 00/>)
500 Nova (00/03)
- Ruggerini** motori RY50
RY70
RY75

Rif. Lombardini: 8565.080/083

Rif. Microcar: 0701023

Rif. Piaggio/Ligier: 850312 • 112161L • 111857L

Rif. Ruggerini: 0085650800/830

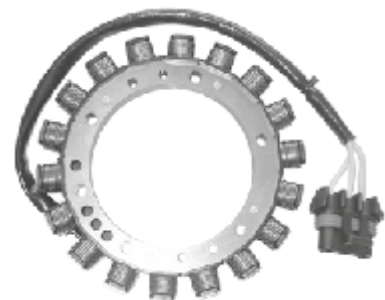

- 16.5237** statore Saprisa 18 poli - 40A - trifase - regolazione 12V - Ø est. 151 - Ø int. 92

Di primo equipaggiamento su:

- Aixam** 500.5 benzina/minivan benzina (97/04)
- Lombardini** motori Focs LDW 502/602/1204 (45A)
Superfocs LDW 702/1003/1404 (45A)
- Bellier** 500 Divane
500 VX (mot. Lombardini 45A)
- Grecav** EKE/XL/Pick-Up Diesel
- Piaggio** 500 PK (05/08 - alternatore interno)
AL 500 Diesel (04/07)

Rif. Lombardini: 8565.064/094/096

Rif. Piaggio/Ligier: 850359/112933L



16.6719 alternatore 12V/45A - rotazione dx - c/puleggia

Per:

Kawasaki UTV KAF950 Mule 2510 Diesel
KAF950 Mule 3010 Diesel 4X4/Trans Diesel
KAF950 Mule 4010 Diesel 4X4
KAF950 Mule 4010 Trans4x4 Diesel/Realtree

Motori **Briggs and Stratton**

430447
432447
433447
437447
522447
580447
581447
582447

Trattori compatti

Cub Cadet 5234/5264/7264 (98/06 - mot. Daihatsu diesel 23/26HP)
toro falciatrici Greensmaster 3200 (95/98 - mot. Daihatsu)

Rif. Kawasaki: 21001-1176

Rif. Briggs&Stratton: 825084

Rif. Daihatsu: 27060-87211 • 27060-87212

Equivalente **Denso 100211-4621 • 100211-4630/4631**



16.6720 alternatore 12V/40A - rotazione dx - c/puleggia

Per:

mot. **Kubota** A28 (86/>)
Z400/402/482 Diesel

Aixam 400/L/SL/E/S Diesel
400 500.4/500.5 Berlina/MiniVan/Pick-Up
400 MAC Cabriolet
400 Scouty/Cabriolet
400 A 721
400 A 741
400 Evolution/400.4
400 Mega Utilitaire
500 Evolution
500/E/L/SL/UT Diesel
500 MAC/Cabriolet
500 Roadline Diesel
500 A 751 Diesel
500 CrossLine VSP Diesel
500 City/City Sport Diesel (motori Kubota Diesel Z400/
Z402/Z482)

Piaggio Porter 1000 (92/94)

Rif. Aixam: K15881-6420

Rif. Daihatsu: 27060-87201/202

Rif. Kubota: 15881-64200/64201

Rif. Denso: 100211-1680 • 100211-1610/30/40 • 100211-4690 • 101211-2480



16.6722 alternatore 12V/55A - rotazione dx

Per:

Kubota ATV - UTV 900 RTV G (Mot. D902-E-UV)
900 RTV T (Mot. D902E3UV)
900 RTV T (Mot. D902-E-UV)
900 RTV W (Mot. D902-E-UV)
900 RTV R (Mot. D902-E-UV)
900 RTV X900R (Mot. D902)
900 RTV X900W (Mot. D902)
900 RTV X900G-A/G-H (Mot. D902)
1100 RTV (Mot. D1105-E2-UV)
1100 RTV CW9 (Mot. D1105E3UV)
1100 RTV RW9 (Mot. D1105E3UV)
1120 RTV-X D (Mot. D1105-E4-UV)
1140 RTV CPX (Mot. D1105E3UV)

Rif. orig.: K7561-61910 • K7561-61911 • K7561-61912

Equivalente **Denso 101211-8770 • 101211-8771**



16.6724 alternatore 12V/14A a magneti permanenti

Per:

Kubota 1981/2006

UTV - Super Mini Series c/motori: Z482, D662, D722

UTV RTV 500 (Mot. GDZ460)

B Series Compact Tractors

B1550 2WD/HST/4WD/Hydrostat (HST)
B1750 2WD/HST/4WD/Hydrostat (HST)
B20 - B2150 2WD/Hydrostat (HST)
B20 - B2150 4WD/Hydrostat (HST)
B5200 2WD - B5200 4WD
B6200 2WD/HST/4WD/Hydrostat (HST)
B7200 2WD/HST/4WD/Hydrostat (HST)
B7410 2WD/HST/4WD/Hydrostat (HST)
B8200 2WD/HST/4WD/Hydrostat (HST)
B9200 2WD/HST/4WD/Hydrostat (HST)

BX Series Sub-Compact Tractors

BX1500 BX1800
BX1830 BX22
BX2200 BX2230
BX23

F / GF Series Commercial Front Mowers

F2000 F2100E
GF1800/E

G/GR Series Lawn Tractors

G1800/S G1900/S
G2000/S GR2110

K Series Excavators

K008-3 ZD

Zero Turn Mowers

ZD18 ZD21
ZD25 F ZD28
ZD321 ZD323
ZD326 P ZD331 LP

Rif. orig.: 15531-64013/16 • 15531-64017 • 6C040-59250 • EG673-64010

Equivalente **Kokusan-Denki**

16.6725 alternatore 12V/40A - rotazione dx - c/puleggia

Per:
Arctic Cat ATV 700 Diesel (07/12)

Lombardini Mot. LDW 442 CRS DCI Diesel Common Rail
FOCS Diesel LDW 502 Progress/Citycar AL
LDW 702/P
LGW 523 MPI Progress Benzina

Aixam 500 Scouty/Cabriolet/GT/R/Benzina
500.5 Benzina (05/>)

Bellier 500 Divane (mot. Lombardini)

Grecav 440 Sonique DCI (Diesel Common Rail)

JDM 500 Aloes Comfort/Luxe Diesel (10/>)

Ligier 500 X-TOO Max i Benzina
500 X-TOO Max Diesel
500 X-TOO R DCI
500 X-TOO R Diesel
500 X-TOO R i Benzina
500 X-TOO S Diesel
500 X-TOO RS Diesel
500 X-TOO RS DCI
500 X-TOO RS i Benzina
500 IXO DCI
500 Optimax/Primo Diesel
500 Optimax DCI

Chatenet 500 Speedino Benzina
500 Barooder X4 Benzina
500 CH26 (Diesel Common Rail)

Microcar 500 MC/MC1/MC2 City (06/> - Diesel Lombardini)
500 Virgo III (mot. seconda versione da n. 4515258)
500 M.GO S/S Pack (08/> - Diesel)
500 M.GO F8 (08/> - Diesel)
500 M.GO F6 DCI (09/>)
500 New F8 DCI (10/>)
500 M.GO SXI DCI (09/> - Diesel Common Rail)
500 M.GO Family 4P (08/> - Benzina)

Piaggio Porter Quargo 500 (05/09 - cruscotto digitale)
PK500
M500/XL
Quargo Diesel 750 (04/07)

Rif. Aixam: 1ACL074

Rif. Arctic Cat: 3206-303

Rif. Bellier: DVMB28

Rif. Ligier: 11.2.958

Rif. Lombardini: 1157-326

Rif. Microcar: 1 000 502

Rif. Piaggio: 493787

Rif. Denso: 101211-3720

16.6727 alternatore 12V/40A - rotazione dx - c/puleggia

Per:
Mot.i Yanmar 523 Diesel 2TNE68
DM4

Bellier 500 Asso
500 Atoli Diesel (mot. Yanmar)
520 Divane Diesel (01/> - mot. Yanmar)
520 Docker City Diesel (mot. Yanmar)
520 Jade Diesel Urban/Classic/SoGood/Racing
520 Opale/2 Diesel (mot. Yanmar)
500 Utylitaire/Transporter Diesel (mot. Yanmar)
550/650 VX Diesel (mot. Yanmar)

Chatenet CH22 Barooder (Yanmar)
CH26 Diesel (Yanmar)

JDM 500 Abaca Plus/Privilege/Fun/Mountain (05/> - mot. Yanmar)
500 Albizia/UT Diesel (02/> - mot. Yanmar)
500 Aloes Fun/Comfort/Luxe Diesel (08/>)
500 Orane (96/> - mot. Yanmar)
500 Titane I/II/III (97/> - mot. Yanmar)
500 MaxUt Diesel (08/> - mot. Yanmar)
500 X5 GTI/Croisiere (98/> - mot. Yanmar)

John Deere UTV 6x4 Gator Diesel/M-Gator/Military
UTV 6x4 Gator Diesel/TH/Pro
UTV 6x4 Trail Gator Diesel
UTV XPX Gator Diesel
UTV XUV Gator 850D/855D Diesel

Microcar 500 MC Exclusive/Limited/Sun/Paris (07/> - mot. Yanmar Diesel)
500 MC1 Generic/City/Campus/Dynamic (03/04 - mot. Yanmar Diesel)
500 MC2 Dynamic/Preference Diesel (05/08 - mot. Yanmar Diesel)
500 M.GO SXI Classic (08/>)
M.GO Cream (08/> - mot. Yanmar Diesel)
500 M.GO F8 Diesel (08/> - mot. Yanmar)

Rif. Bellier: VMBY43

Rif. Chatenet: 0117076

Rif. John Deere: AM877740

Rif. Microcar: 1005075

Rif. Yanmar: 119620-77201/02

Rif. Denso: 100211-4530/31

RICAMBI PER ALTERNATORI ESTERNI SAPRISA A MAGNETI PERMANENTI



16.6728 alternatore 12V/33A - rotazione dx - c/puleggia

Adattabile su:

| | | |
|------------------|---|--|
| Trattori | Agritalia Allis Chalmers Deutz International KHD Lamborghini | Bomag Case Goldoni John Deere Kramer |
| Motori | Marini BPM Farymann | Deutz |
| VM Motori | MH 11 102/103 HR 292A/392A 12,5KVA 1052SU 18KVA 1052SU 20KVA HR392A 24KVA 1053 292RA 3105/3105 M | MH11 1052/1053 RA 294/394 15KVA 1052SU 20KVA 1053 2105/2105 M 25KVA 1053 30KVA 1053 392RA |

Rif. Bosch: 0 120 300 514 • 0 120 300 515 • 0 120 300 552 • 0 120 300 560 • 0 120 339 514
0 120 339 526 • 0 120 339 531 • 0 120 400 737 • 0 986 030 130 • 0 986 033 070
Rif. Deutz: 1171617 • 1177481 • 1163985 | Rif. John Deere: AZ23575 | Rif. Iskra: IA0096



16.6729 alternatore 12V/33A - rotazione dx - s/puleggia

Adattabile su:

| | | |
|-------------------|---|--|
| Trattori | Agrifull Bertolini Fendt Muzzi (mot. VM) Palmieri (mot. VM) | Arona Case Ferrari (mot. Lombardini) Goldoni (mot. Lombardini) Valpadana (mot. Lombardini) |
| Lombardini | 10LD 400.2/B1 11LD 625.3 12LD 435.2 12LD 475 5LD 675.3 5LD 825.3L 5LD 825.4 5LD 930.3 5LD 930.4 832 834 904 9LD 561.2 2W.2L L20 8LD665.2L L40 5LD825.3L LDA 672 LDA 674 LDA 833 5LD825.3 LDAL 672 LDAL 674 | 11LD 535.3 11LD 626.3 12LD 435.2/B1 5LD 675.2 5LD 825.2L 5LD 825.3T 5LD 825.4L 5LD 930.3L 5LD 930.4L 833 8LD 740.2 914 9LD 625.2 L27 5LD825.2L L54 5LD825.4L LDA 673 LDA 832 LDA 834 5LD825.4 LDAL 673 |
| VM Motori | 04 M11 1054 SU 1056 SU 106 MH11 32,5 KVA 1054SU 4105 M 5 KVA HR192A 60 KVA 1056SU 6105 6105 T HR 192A T 1054SU | 1054 M11 1056 M11 106 M11 1154M 4105 4105 T 50 KVA 1056SU 60 KVA T1056SU 6105 M 70 KVA T1056SU HR 294HP T 1056SU |

Rif. Bosch: 0 120 339 535 • 0 120 339 536 • 0 986 030 140 | Rif. Iskra: IA0507



16.9992 statore ricambio - per alternatori Saprisa 12V/300W c.c. (fig. 1)

16.6603 puleggia ricambio - per alternatori Saprisa (albero Ø 17) (fig. 2)

16.66031 puleggia ricambio - per alternatori Saprisa (albero Ø 14) (fig. 2)

N.B.: i suddetti ricambi sono utilizzabili solo su alternatori Saprisa.

Alternatori

PIAGGIO

16.6730 Alternatore 12V 65A

Per:

PIAGGIO Porter 1200/1400 Diesel (95/00) • Porter 1400 Van Diesel (98/05)
Porter 1400 Pick-Up Diesel (98/05)

Rif. orig.: 493990

Equivalente Lombardini 1157264



16.6735 Alternatore 12V 45A

Per:

PIAGGIO Porter 1300 Pick-Up/Van (92/09) • Porter 1300 16V Van (98/07)
Porter 1300 16V Pick-Up/Maxxi (98/09) • Porter 1300 16V GPL/4x4 (98/09)
Porter 1300 Pick-Up/Van Up Date (09/10) • Porter 1300 Maxxi Up Date (09/10)

Rif. orig.: 2706087512

Equivalente Denso 102211-6730



Statori

KYMCO

16.9031 **Statore 18 poli trifase - c/pick-up a 2 cavi**

Per:
KYMCO People S 200i (07/15)

Rif. Kymco: 31120-KKE3-90A
Rif. PD: 0128224



16.9039 **Statore trifase 18 poli - c/pick-up 2 cavi**

Per:
KYMCO 200 Downtown (10/15) • 200 People GTI IE (10/15) • 300 Downtown (09/15)
300 Downtown ABS (09/16) • 300 People GTI ABS E4 (16/20)
300 People GTI IE / ABS (10/16)

Rif. Kymco: 31120LEA7E0B
Rif. Padana Ricambi: 00131071



MOTOM VARI

16.9033 **Statore 12 poli trifase - c/pic-up a 1 cavo**

Per:
MOTOM Dolcevita 150 • scooter vari 150 mot. Cina



GR. 13 MATERIALE ELETTRICO

PIAGGIO

16.43711 **Statore elettronico 6 poli c/piastra**

Per:

PIAGGIO Vespa PX-E 125/150/200/Arcobaleno (81/97)
Vespa PX 125/150/200 (98/11)

Rif. orig.: 231877

Equivalente SGR 16.4371



SYM

16.9032 **Statore 8 poli monofase**

Per:

SYM 125 Symphony S (10/14) • 125 Symphony SR (10/14)
150 Symphony S (10/14) • 150 Symphony SR (10/14)

Rif. orig.: 31120-Z7A-000

