



FIGURATO GANASCE

BRAKE SHOES DRAWINGS AND APPLICATIONS
DESSINS MÂCHOIRES DE FREIN AVEC APPLICATIONS
DISEÑOS MORDAZAS CON RELACIÓN
ZEICHNUNGEN VON BREMSBACKEN MIT VERWENDUNGSLISTE

GF0024 STD | FTR | PRO

øt (mm): 150 (mm): 25

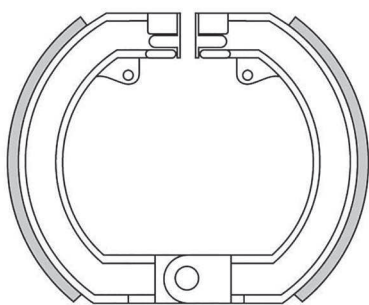

GF0084 STD

øt (mm): 136 (mm): 25

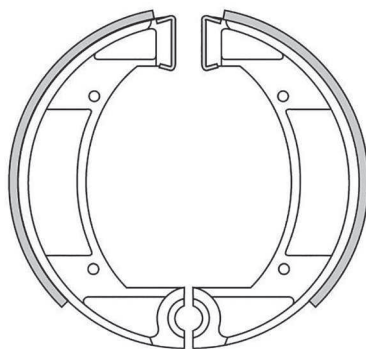

GF0089 STD | FTR | PRO

øt (mm): 152 (mm): 25

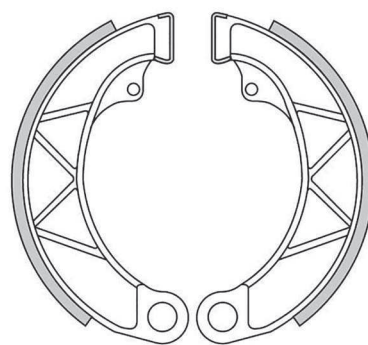

PIAGGIO	Year	A/P
VESPA 125	75->76	A
VESPA 150 SPRINT VELOCE (VLB1)	65->74	A
VESPA 160 GS	75->	A
VESPA 180 SS	75->	A
VESPA 200 RALLY	75->	A

FANTIC	Year	A/P
RSX 125	81->	A / P
TRIAL 125 7 DAYS(mozzi centrali)		P

INNOCENTI	Year	A/P
LAMBRETTA 125 LI	58->59	A / P
LAMBRETTA 125 LI II	59->61	A / P
LAMBRETTA 125 LI III	61->69	A / P
LAMBRETTA 150 LI I	58->59	A / P
LAMBRETTA 150 LI II	59->61	A / P
LAMBRETTA 150 LI III	61->69	A / P
LAMBRETTA 150 SX	66->69	A / P
LAMBRETTA 175 TV I	57->59	A / P
LAMBRETTA 175 TV II	59->61	A / P
LAMBRETTA 175 TV III	62->67	P
LAMBRETTA 200 GT (UK)	63->65	P
LAMBRETTA 200 SX	66->68	P
LAMBRETTA 200 TV III	63->65	P

GF0035 STD

øt (mm): 105 (mm): 20

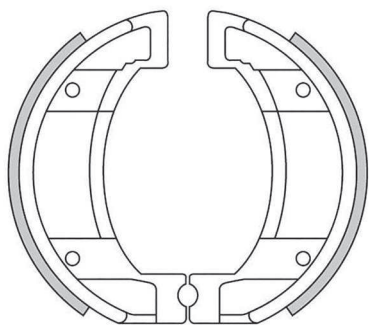

MAICO	Year	A/P
GSE 250 ALPHA-E	->83	A
LINK 250	->83	A
MX 250 TWIN	->83	A
400	->83	A
MX 490 LINK	->83	A
MX 490 TWIN	->83	A

MOTO GUZZI	Year	A/P
CROSS 50	75->82	A / P
NIBBIO 50	75->76	A / P

MOTO MORINI	Year	A/P
KJ 125	84->	P
MONOCILINDRO 125	79->	P
SPORT 250	->70	P
TURISMO 250	->70	P

GF0093 STD

øt (mm): 135 (mm): 30

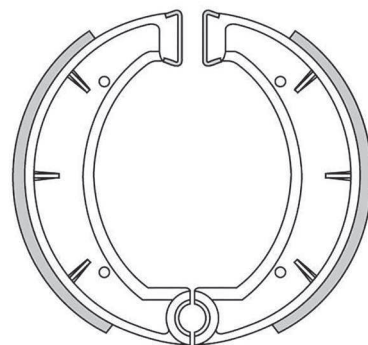

MOTOM	Year	A/P
MOTOM 50		A / P

GF0071 STD

øt (mm): 116 (mm): 20

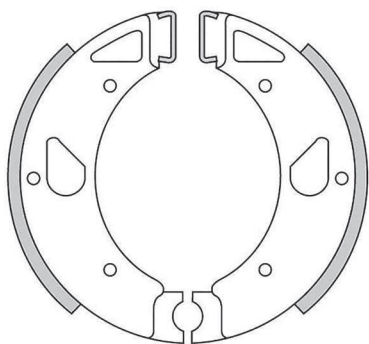

GF0087 STD | FTR | PRO

øt (mm): 127 (mm): 23

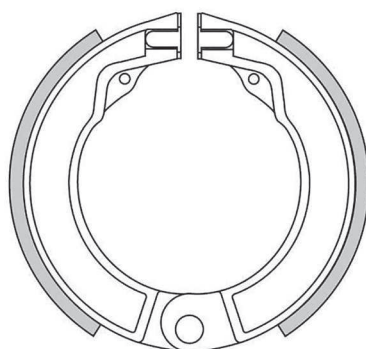

MOTO MORINI	Year	A/P
CORSARO 125	->70	A / P
MONELLO 125	->70	A / P
SETTEBELLO 175	->70	A / P
TURISMO 175	->70	A / P

KREIDLER	Year	A/P
FLORETT 80	80->	A / P

PIAGGIO	Year	A/P
VESPA 125	58->62	P
VESPA 125 (da V1T a V15T - da V30T a V33T)	46->52	P
VESPA 125 (VM1/2T - VU1T)	53->54	P
VESPA 125 (VN1/2T)	55->57	P
VESPA 150 (VL1/2/3T)	55->57	P
VESPA 150 GS (VS1)	55	P
VESPA 150 GS (VS2/3/4)	56->58	P
VESPA 150 GS (VS5 da tel 47351 a tel 63168)	59->61	P

FIGURATO GANASCE CON APPLICAZIONI | BRAKE SHOES DRAWINGS AND APPLICATIONS | DESSINS MÂCHOIRES DE FREIN AVEC APPLICATIONS |
 DISEÑOS MORDAZAS CON RELACIÓN | ZEICHNUNGEN VON BREMSBACKEN MIT VERWENDUNGSLISTE



GF0097
STD | FTR

øt (mm): 123 (mm): 25

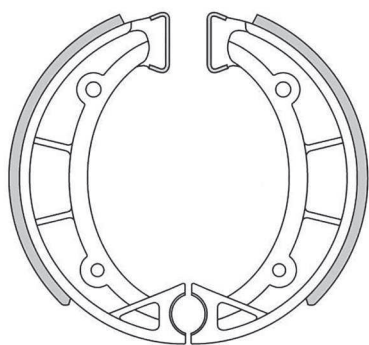

BETA	Year	A/P
MX6 50 EXPORT	77->	A / P
TR 50	80->86	P
TR 80	80->	P
CR 125	->81	A
RC 125	76->	A

FANTIC	Year	A/P
CABALLERO 50 REG. SUPER 6 M	->83	A / P
ENDURO 50	83->	A / P
R 6 50 SUPER		A / P
TRIAL 50 I SERIE (mozzi centrali)	->83	P
TRIAL 80	->83	A / P
TRIAL 125 7 DAYS(mozzi centrali)		A
TRIAL 125 I SERIE. (tEL. grig. m. cen)		P
TRIAL 125 II SERIE (tel.rosso, m.cen)		A / P

GILERA	Year	A/P
GIUBILEO 98		P
GIUBILEO 124		P
ARCORE 125		P

MALAGUTI	Year	A/P
MDX GOLD 50 ENDURO	87->	P
MEX 50 ENDURO	85->	P
MGX 50 ENDURO	87->	A / P
MLX 50 ENDURO	87->	P
RGT 50 SPORT	85->	P

MOTO GUZZI	Year	A/P
TURISMO 125	74->81	P
TUTTOTERRENO 125	74->81	A / P

GF0113
STD

øt (mm): 140 (mm): 25

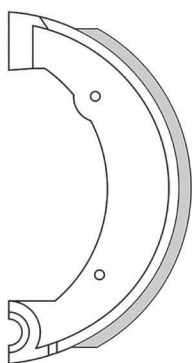

MOTO GUZZI	Year	A/P
SCRAMBLER 50	71->74	A / P
SPORT 125	60->68	A / P
STORNELLO 125	60->68	A / P
STORNELLO 125 5 marce		A / P
STORNELLO 160 4 marce	68->70	A / P
STORNELLO 160 5 marce	71->74	P

GF0127
STD | PRO

øt (mm): 135 (mm): 23

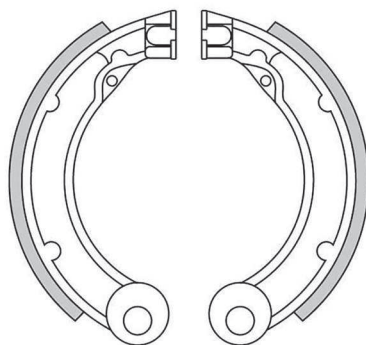

PIAGGIO	Year	A/P
VESPA 125	63->72	P
VESPA 125 PRIMAVERA (1 serie)	66	P
VESPA 150	63->72	P

GF0128
STD | FTR | PRO

øt (mm): 150 (mm): 24

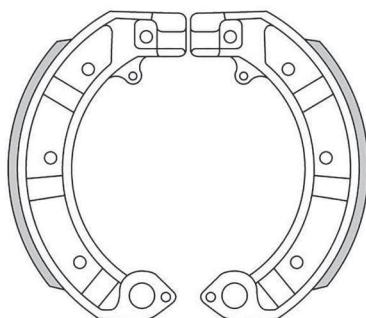

PIAGGIO	Year	A/P
VESPA 50 FL2 AUTOMATICA	90->91	A
VESPA 50 HP FL2	92->	A / P
VESPA 50 PK	83->	P
VESPA 50 PK AUTOMATICA (VAM1T)	84->89	A
VESPA 50 PK SPECIAL -XL	86->	P
VESPA 50 PK XL 2	86->	A / P
VESPA 50 V FL 2	90->	A / P
VESPA 80		P
VESPA 80 PX		P
VESPA 80 SPECIAL		P
VESPA 125	75->76	P
VESPA 125	77->	A
VESPA 125 FL	89->90	A / P
VESPA 125 PK AUTOMATICA	84->	A
VESPA 125 PK SPECIAL -XL	86->89	A / P
VESPA 125 PK XL 2	84->	A / P
VESPA 125 PX	78->81	A
VESPA 125 PX	78->17	P
VESPA 125 PX ARCOBALENO	81->97	A / P
VESPA 125 V FL2	91->	A / P
VESPA 150 PX	78->91	A
VESPA 150 PX	78->17	P
VESPA 150 PX ARCOBALENO	83->97	A / P
VESPA 150 SPRINT VELOCE (VLB1)	65->74	P
VESPA 150 TS (VNL3T)	75->78	A / P
VESPA 160 GS	75->	P
VESPA 180 SS	75->	P
VESPA 200 PE	83->	A / P
VESPA 200 PX	98->	P
VESPA 200 PX ARCOBALENO	83->	A / P
VESPA 200 PX E	78->	A / P
VESPA 200 RALLY	75->	P

GF0130
STD | FTR | PRO

øt (mm): 135 (mm): 20

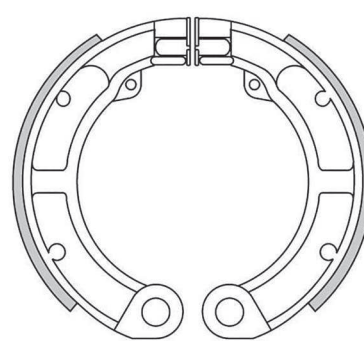

PIAGGIO	Year	A/P
VESPA 50 L - N	63->	P

GF0150
STD

øt (mm): 150 (mm): 22

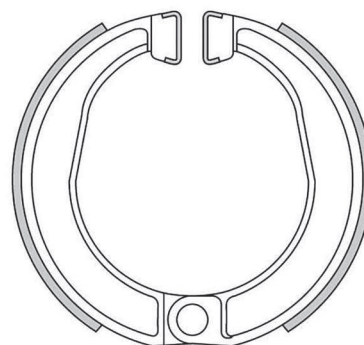

INNOCENTI	Year	A/P
LAMBRETTA 100 2T (CENTO)	64->65	A / P
LAMBRETTA J 125 2T JUNIOR	64->69	A / P

GF0151
STD | PRO

øt (mm): 90 (mm): 18

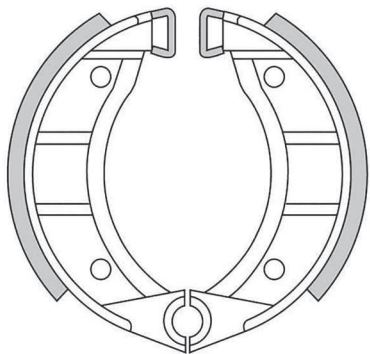

BENELLI	Year	A/P
BOBO 50	78->	A / P
EXPORT 3 V 50	79->	A / P
G 2 50	79->	A / P
MOTORELLA 50	79->	A / P

BETA	Year	A/P
ANDY 50 ruote lega	78->	A / P
ANDY 50 ruote raggi	78->	A / P
B12 50	73->	A / P
MIO 50	79->	A / P

FANTIC	Year	A/P
ISSIMO 50 (ruote raggi)		A / P

GARELLI	Year	A/P
BASIC 50 (ruota raggi)		A / P
EUREKA 50		A / P
GULP 50		A / P
NOI 50 (ruota raggi)		A / P
NOI 50 MATIC		A / P
SUPER VIP 50		A / P
VIP 50 (ruota raggi)		A / P

GILERA	Year	A/P
CB 1 50		A
CBA 50		A
CBA variatore 50	86->	A
ECO 50		A

MALAGUTI	Year	A/P
CHOPPER 25	->82	P
ciclomotori 50 all models	->83	P
LX 50 SPORT	->82	P
RCW 50 RONCO	->82	P
VA 50 OLYMPIQUE	->82	P
CHOPPER 80	->82	P

MOTO GUZZI	Year	A/P
CHIU 50	74->76	A / P
DINGO 50 3 V	75->76	A / P
DINGO 50 3M	66->74	A / P
DINGO 50 M	69->73	A / P
DINGO 50 MM	75->76	A / P
MAGNUM 50	75->76	A / P
TROTTER 50	66->70	A / P
TROTTER 50 MARK M - V	71->73	A / P
TROTTER 50 SPECIAL M - V	71->73	A / P
TROTTER 50 SUPER	66->70	A / P

PIAGGIO	Year	A/P
BOXER 50		A
BOXER variatore 50		A
BRAVO 50		A
BRAVO variatore 50		A
CIAO 50		A
CIAO variatore 50		A
FREE 50	93->95	A
SI 50		A

...GF0151

... segue PIAGGIO	Year	A/P
SUPER BRAVO 50	85->	A
VESPIANO 50	->79	A

RIZZATO	Year	A/P
ATALA UNO 50 (ruota raggi)		A / P

TOMOS	Year	A/P
K 83		A / P
M 83		A / P

GF0152
STD | FTR | PRO

øt (mm): 105 (mm): 20

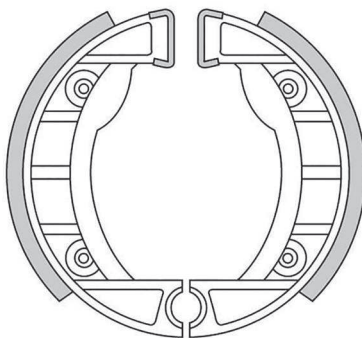

BETA	Year	A/P
PULMAN 50	70->	A / P

FANTIC	Year	A/P
SPRINTER 50	84->	A / P
SPRINTER 50 3V.R (FM. 248)	83->	A / P

GARELLI	Year	A/P
JUNIOR 50 TURISMO (ruota raggi)		A / P

GILERA	Year	A/P
TREND 50	89->	A

ITALJET	Year	A/P
SHOPPING 50	90->	A

PIAGGIO	Year	A/P
BRAVO 50 (ruote in lega)	87->	A
BRAVO variatore 50 (ruote in lega)	87->	A
CIAO 50 (ruote in lega)	87->	A
CIAO variatore 50 (ruote in lega)	87->	A
GRILLO 50	89->	A
GRILLO variatore 50	89->	A
SI variatore 50 (ruote in lega)	80->	A
SUPERBRAVO 50 3 Marce	87->	A
VESPIANO 50	80->	A

RIZZATO	Year	A/P
ATALA CALIFFONE 50 (ruota raggi)		A / P

GF0153
STD

øt (mm): 118 (mm): 20

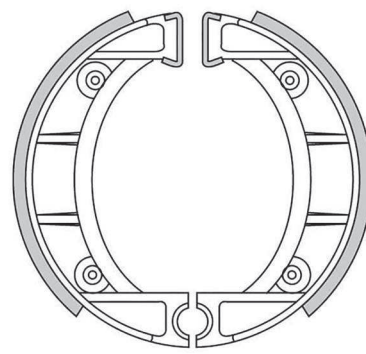

ACCOSSATO	Year	A/P
50 CROSS MINI	82->	A / P

APRILIA	Year	A/P
ET 50	84->86	A
RC 50	->83	A / P

ASPE	Year	A/P
CS 50 NAVAHO	76->	A / P

BETA	Year	A/P
FOUR 50 AE	87->	P
FOUR 50 S	87->	P

FOUR TWIN 50	Year	A/P
	88->	P

M4 50	Year	A/P
	83->	P

M6 50	Year	A/P
	83->	P

MS 50	Year	A/P
	80->	P

MX4 50 Special	Year	A/P
	70->	A / P

SCRAMBLER 50 4 M	Year	A/P
	82->	A / P

SQUIRREL 50	Year	A/P
	83->	P

TR 50	Year	A/P
	80->86	A

TR 80	Year	A/P
	80->	A

FANTIC	Year	A/P
TRIAL 50 I SERIE (mozzi centrali)	->83	A

TRIAL 125 I SERIE (Tel. grig. m. cen)	Year	A/P
		A

GARELLI	Year	A/P
CICLONE 50 I SERIE (ruota raggi)		A / P

CICLONE 50 II SERIE (ruota lega)	Year	A/P
		A / P

CICLONE 50 N DE LUXE SELF MIX L.C	Year	A/P
		P

CICLONE 50 N/N DE LUXE SELF MIX L	Year	A/P
		A / P

GRAN TURISMO 50 (ruota lega)	Year	A/P
		A / P

KL 50 SV	Year	A/P
		A / P

MALAGUTI	Year	A/P
CENTRO 50	93->94	A

FIFTY 50 4 MARCE	Year	A/P
	87->	A / P

FIFTY 50 FULL all models	Year	A/P
	83->93	P

FIFTY 50 HF	Year	A/P
	87->	A / P

FIFTY 50 HF (freno a disco)	Year	A/P
	->82	P

FIFTY 50 NL	Year	A/P
	87->	A / P

FIFTY 50 TOP	Year	A/P
	85->	P

WC 50 WATER COOLED	Year	A/P
	->82	P

MOTO GUZZI	Year	A/P
DINGO 50 CROSS	66->74	A / P
DINGO 50 GT	66->74	A / P
DINGO 50 SPORT	66->74	A / P
DINGO 50 SUPER	66->74	A / P
DINGO 50 TURISMO	66->74	A / P

RIZZATO	Year	A/P
ATALA CALIFFONE 50 (ruota in lega)		A / P
ATALA MASTER 50 (ruota in lega)		A / P

SWM	Year	A/P
TL 50 TRIAL	->83	A / P
TR 50	->83	A / P
TL 80 TRIAL	->83	A / P
TR 80	->83	A / P

FIGURATO GANASCE CON APPLICAZIONI | BRAKE SHOES DRAWINGS AND APPLICATIONS | DESSINS MÂCHOIRES DE FREIN AVEC APPLICATIONS | DISEÑOS MORDAZAS CON RELACIÓN | ZEICHNUNGEN VON BREMSBACKEN MIT VERWENDUNGSLISTE



GF0155
STD

øt (mm): 180 (mm): 30

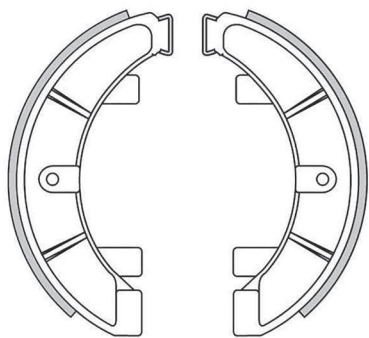

INNOCENTI	Year	A/P
LAMBRO 450 MOTOCARRO		P
LAMBRO 500 MOTOCARRO		P

GF0159
STD | FTR | PRO

øt (mm): 150 (mm): 24

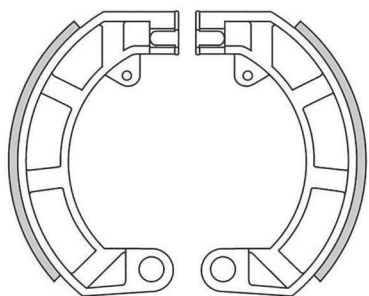

PIAGGIO	Year	A/P
VESPA 50 SPECIAL	63->	P
VESPA 90 PRIMAVERA	58->	P
VESPA 125 ET3		P
VESPA 125 ETS	84->	P
VESPA 125 PRIMAVERA	67->73	P

GF0160
STD | FTR | PRO

øt (mm): 127 (mm): 28

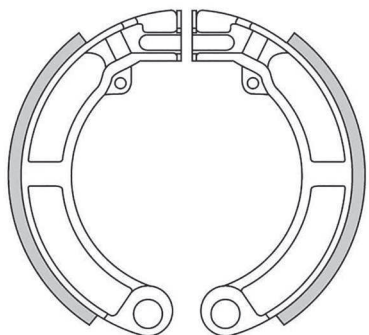

PIAGGIO	Year	A/P
VESPA 150 SUPER (VBC1T)	65->66	P

GF0162
STD | FTR | PRO

øt (mm): 125 (mm): 17

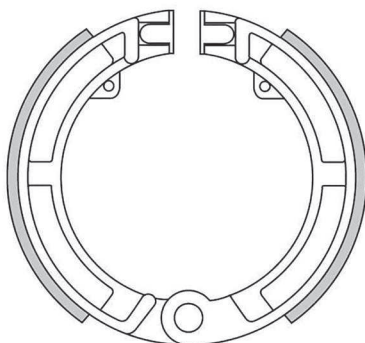

PIAGGIO	Year	A/P
APE 50 EURO 2	03->16	A
APE 50 FL / FL2	89->95	A
APE 50 FL3 EUROPA	96->99	A
APE 50 MIX 2T	98->08	A
APE 50 P	80->85	A
APE 50 RST MIX	99->05	A
APE 50 TM P	85->89	A
VESPA 50 L - N	63->	A
VESPA 50 PK	83->	A
VESPA 50 PK AUTOMATICA (VA51T)	84->89	A
VESPA 50 PK SPECIAL - XL	86->	A
VESPA 50 PK XL PLURIMATIC	85->90	A
VESPA 50 SPECIAL	63->	A
VESPA 80		A
VESPA 80 PX		A
VESPA 80 SPECIAL		A
VESPA 90 PRIMAVERA	58->	A
VESPA 98	46->47	A
VESPA 125	58->72	A
VESPA 125 (da V1T a V15T - da V30T a V33T)	46->52	A
VESPA 125 (VM1/2T - VU1T)	53->54	A
VESPA 125 (VN1/2T)	55->57	A
VESPA 125 ET3		A
VESPA 125 ETS	84->	A
VESPA 125 PRIMAVERA	67->73	A
VESPA 125 PRIMAVERA (1 serie)	66	A
APE 150 C 1/2/3		A
APE 150 C4		A
VESPA 150	63->72	A
VESPA 150 (VL1/2/3T)	55->57	A
VESPA 150 GS (VS1)	55	A
VESPA 150 GS (VS2/3/4)	56->58	A
VESPA 150 GS (VS5 da tel 47351 a tel 63168)	59->61	A
VESPA 150 SUPER (VBC1T)	65->66	A
APE PENTARO 175 con scodellino		A
APE PENTARO 175 senza scodellino		A

GF0165
STD

øt (mm): 180 (mm): 30

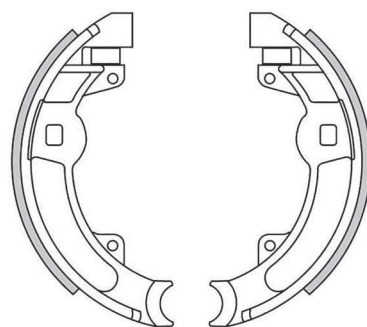

INNOCENTI	Year	A/P
M 500		P
ML 500		P
V 500 MOTOCARRO		P
A 550		P

GF0166/7 (6 pz)
STD

øt (mm): 180 (mm): 41

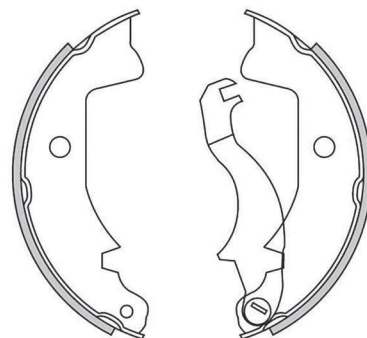

PIAGGIO	Year	A/P
APE MP 220 P 501 (I SERIE) con scodellino		A
APE MP 220 P 501 (I SERIE) senza scodellino		A
APE MP 220 P 601 (I SERIE)	78->	A
APE MP 220 P 601 (I SERIE) senza mozzo	78->	A

GF0170
STD | FTR

øt (mm): 152 (mm): 25

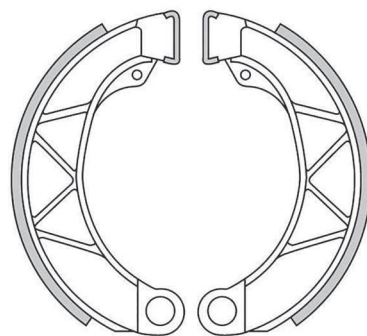

INNOCENTI	Year	A/P
LAMBRETTA 125 DL	69->71	A / P
LAMBRETTA 125 GP (UK)	69->71	A / P
LAMBRETTA 150 DL	69->71	A / P
LAMBRETTA 150 GP (UK)	69->71	A / P
LAMBRETTA 200 DL	69->71	P
LAMBRETTA 200 GP (UK)	69->71	P

SIL	Year	A/P
LAMBRETTA 125 GP	75->00	A / P
LAMBRETTA 150 GP	75->00	A / P
LAMBRETTA 200 GP	75->00	A / P

GF0174 (4 pz)

STD

øt (mm): 160 (mm): 32

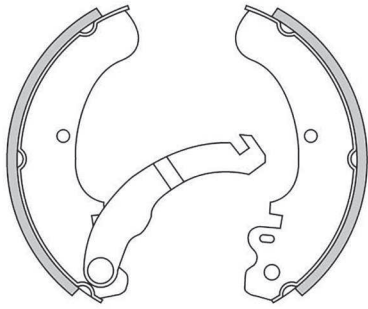

PIAGGIO	Year	A/P
APE 50 EURO 2	03->16	P
APE 50 FL / FL2	89->95	P
APE 50 FL3 EUROPA	96->99	P
APE 50 MIX 2T	98->08	P
APE 50 P	80->85	P
APE 50 RST MIX	99->05	P
APE 50 TM P	85->89	P

GF0176

STD

øt (mm): 220 (mm): 40

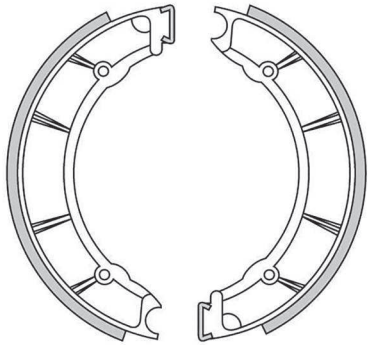

MOTO GUZZI	Year	A/P
V 7 700	67->76	A

GF0177

STD

øt (mm): 220 (mm): 40

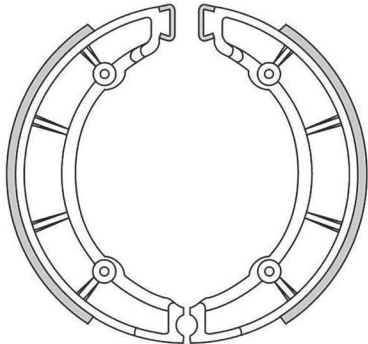

MOTO GUZZI	Year	A/P
V 7 700	67->76	P
V 7 700 SPECIAL	69->71	P

GF0178

STD

øt (mm): 200 (mm): 30

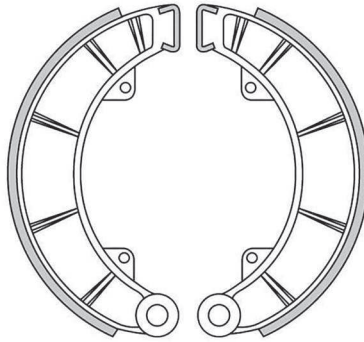

BENELLI	Year	A/P
650	->76	P

LAVERDA	Year	A/P
750 (mozzi Grimeca)	->76	P

GF0179

STD

øt (mm): 220 (mm): 25

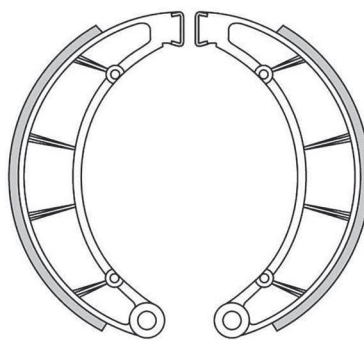

MOTO GUZZI	Year	A/P
V 7 700 SPECIAL	69->71	A
V 750 750 SPORT	72->74	A
CALIFORNIA 850 GT	72->74	A
GT 850	72->74	A
T 850	74->75	P

GF0180

STD

øt (mm): 200 (mm): 30

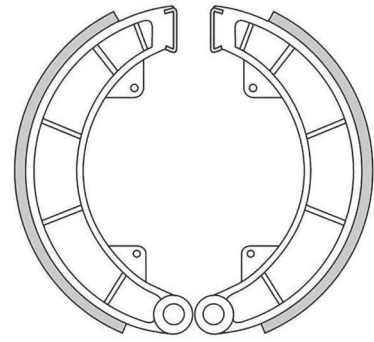

MOTO GUZZI	Year	A/P
FALCONE 500 N	69->76	A

GF0181

STD

øt (mm): 200 (mm): 30

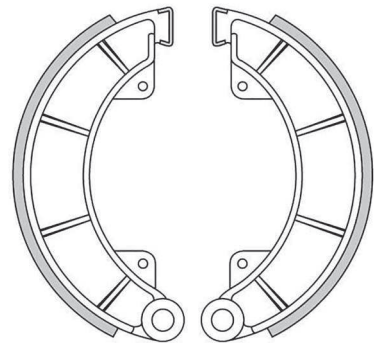

MOTO GUZZI	Year	A/P
FALCONE 500 N	69->76	P

GF0182

STD

øt (mm): 220 (mm): 30

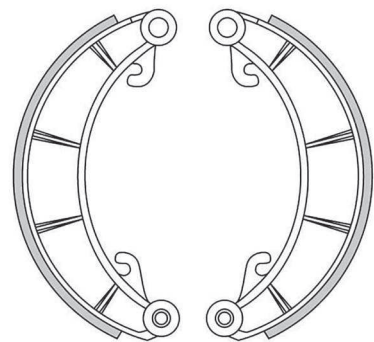

LAVERDA	Year	A/P
750 (mozzi Laverda)	->76	A / P
1000	->76	A / P



GF0183
STD

øt (mm): 158 (mm): 30

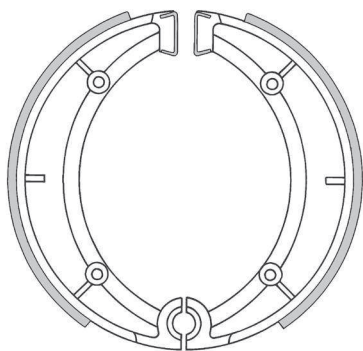

BENELLI	Year	A/P
125	76->	P
125 2 C	76->78	P
125 2T - 2 CSE	76->78	P
2C 125 doppia frenata	->76	P
250 4	76->	P
250 C	76->78	P
250 TS	76->78	P
254	79->	P
350 4 CIL.	78->	P
500 QUATTRO	76->	P

DUCATI	Year	A/P
250	->76	P
350	->76	P
450	->76	P

MOTO GUZZI	Year	A/P
2C 125 4T	79->	P
STORNELLO 160 5 marce	71->74	A
TS 250	74->75	P
254	77->81	P
GTS 350	74->75	P

GF0184
STD

øt (mm): 182 (mm): 35

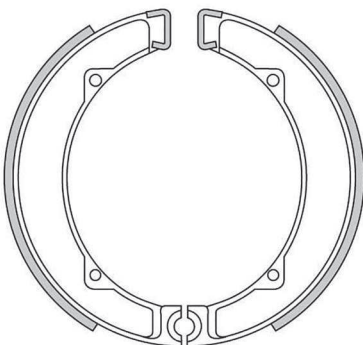

DUCATI	Year	A/P
250	->76	A
350	->76	A
450	->76	A

GF0186
STD

øt (mm): 90 (mm): 18

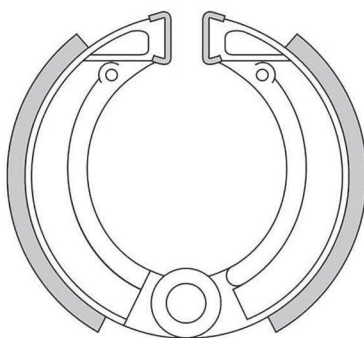

MALANCA	Year	A/P
MALANCA 90 mozzi M.M. 90x18		A

GF0190 (2 pz)
STD | PRO

øt (mm): 135 (mm): 16

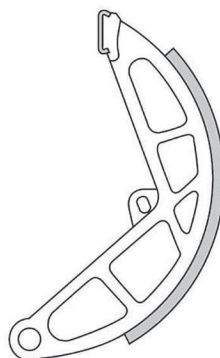

GILERA	Year	A/P
CB 1 50		P
CBA 50		P
CBA variatore 50	86->	P
ECO 50		P
TREND 50	89->	P

ITALJET	Year	A/P
SHOPPING 50	90->	P

PIAGGIO	Year	A/P
BOSS 50	88->	P
BOXER 50		P
BOXER variatore 50		P
BRAVO 50		P
BRAVO 50 (ruote in lega mozzo 90mm)	87->	P
BRAVO 50 (ruote in lega)	87->	P
BRAVO variatore 50		P
BRAVO variatore 50 (ruote in lega mozzo 90mm)	87->	P
CIAO 50		P
CIAO 50 (ruote in lega)	87->	P
CIAO 50 MIX	97->	P
CIAO variatore 50		P
CIAO variatore 50 (ruote in lega)	87->	P
GRILLO 50	89->	P
GRILLO variatore 50	89->	P
SI 50		P
SI 50 MIX	97->	P
SI variatore 50 (ruote in lega)	80->	P
SUPER BRAVO 50	85->	P

GF0197/8 (6 pz)
STD

øt (mm): 180 (mm): 41

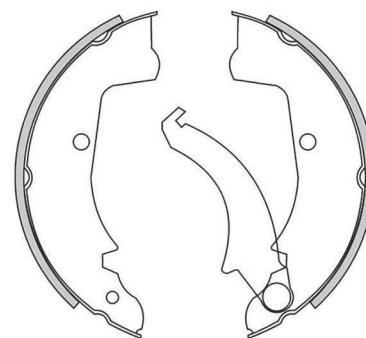

PIAGGIO	Year	A/P
APE CAR 220 P2 / P3	78->85	A
APE MP 220 P 501 (II SERIE)	78->96	A
APE MP 220 P 601 (II SERIE)	78->96	A

GF0200
STD | FTR

øt (mm): 125 (mm): 25

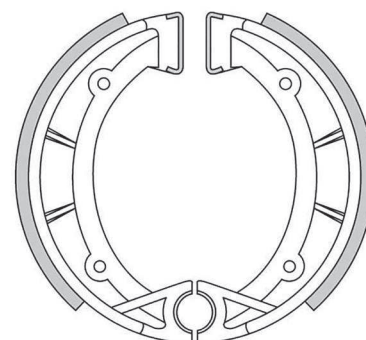

ACCOSSATO	Year	A/P
50 CROSS	->83	A / P
50 ENDURO	->83	A / P
CR 50 CROSS COMPETIZIONE	84->	A / P
CR 50 ENDURO	84->	A / P
CR 50 ENDURO COMPETIZIONE	84->	A / P
80 CROSS	->83	A / P
CE 80 CROSS H20	84->	P
CE 80 ENDURO H20	84->	P
CE 125 CROSS H20	84->	P
CE 125 ENDURO H20	84->	P

ANCILLOTTI	Year	A/P
PS 80 MX	83->	A / P
PST 125 MX	83->	A / P
PSV 250 MX	83->	A

APRILIA	Year	A/P
MX 50	->83	A / P
RC 50 SPECIAL	->83	A / P
MX 125	83->88	A
RX 125	->83	A
RX 125 (mozzi Rimoldi)	84->85	A
TX 125	85	A / P
TX 125 M	86->	P
TX 240	85->	A / P
TX 300	85	A / P
TX 311	87	P
TRIAL 320	81->	A / P

ASPES	Year	A/P
CS 75 50 NAVAHO	76->	A
CM1 80	00	A / P
HOP1 125	00	A
JUMA 125	76->	A

...GF0200		
BETA	Year	A/P
MX6 50	82->	A/P
TR 50	87->88	A/P
TR 50 (SPAIN)	89->	P
RX 125	83	P
TR 125	80->85	A/P
TR 32 125	86	P
TR 33 125	87	P
TR 240	80->83	A/P
TR 32 240	84->85	A/P
TR 32 240 (mozzo ant autocentrante)	84->85	P
TR 33 240	86->88	P
TREKKING 240	87->	A/P

CAGIVA	Year	A/P
SXT 125	82->	P
WMX 125	->82	A/P
WMX 125 (mozzi Rimoldi)	84->	P
WMX 125/3	->83	A/P
WRX 125	82	A/P
WRX 125/1	83->	A/P
XRX 125	80->	A/P
XWMX 125	81->	A/P
WMX 250	82->86	P
WRX 250	->82	A/P

FANTIC	Year	A/P
CASA 50	75->	A/P
COMPETIZIONE 50	75->	A/P
ENDURO 50 COMPETITION	->82	A/P
ENDURO 50 REPLICA	80->	A/P
FAST 50	88->	P
GRAN TURISMO 50 FOUR (FM. 200)	->82	A/P
REPLICA 50	->80	A/P
STRADA 50 (FM. 240)	82->	P
STRADA 50 SUPER SIX	73->	P
CROSS 80 COMPETITION	->80	A/P
ENDURO 80	80->	A
CABALLERO 125 REGOLARITA	81->84	A
CROSS 125 COMPETITION	80->	A
ENDURO 125	80->	A
TRIAL 125 .1 Progress 1	87->88	P
TRIAL 125 .1 Progress 2	85->86	P
TRIAL 125 7 DAYS mozzi conici		A/P
TRIAL 125 III SERIE (mozzi conici)		A/P
TRIAL 125 PROFESSIONAL (FM.237)	83->84	A/P
TRIAL 200	85->86	P
TRIAL 200 (FM. 350)	78->	A/P
TRIAL 200 Progress 1	86->	P
TRIAL 201 Progress2	86->	P
TRIAL 240 (FM. 450)	->83	A/P
TRIAL 240 SEVEN DAYS (FM. 289)	86	P
TRIAL 241 PROFESSIONAL	86	P
COACH 250	91->	P
TRIAL 300 (FM. 403)	84	P
TRIAL 301 Progress 1 (FM. 266)	85	P
TRIAL 301 Progress 2	86	P

GARELLI	Year	A/P
TRIAL 320	->85	A/P

GILERA	Year	A/P
E1 125		A
E1 125 COMPETIZIONE		A

MALANCA	Year	A/P
MARK 125	85->	P

PUCH	Year	A/P
GS 80 V	83->	A/P
FS 125 REGOLARITA	83->	A/P
F5 250	84->	A

SWM	Year	A/P
GS 50 RBS ENDURO	83->	A/P
MC 50 CROSS	83->	A/P

...GF0200		
... segue SWM	Year	A/P
MK 50	83->	A/P
GS 80 RBS ENDURO	83->	A/P
MC 80 CROSS	83->	A/P
MK 80	83->	A/P
HW 125	->83	A/P
MW 125 TRIAL	->83	A/P
TL 125	->83	A/P
HW 240	->83	A/P
MW 240 TRIAL	->83	A/P
TL 240	->83	A/P
TRIAL 240	->83	A/P
HW 320	->83	A/P
MW 320 TRIAL	->83	A/P
TL 320	->83	A/P
TRIAL 320	->83	A/P
HW 350	->83	A/P
MW 350 TRIAL	->83	A/P
TL 350	->83	A/P

GF0200A

STD

øt (mm): 125 (mm): 25

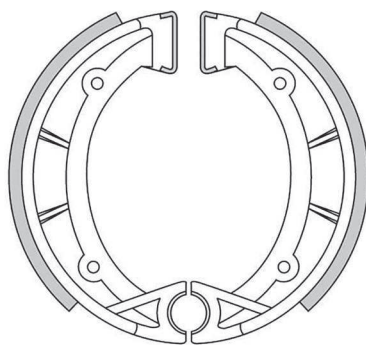

APRILIA	Year	A/P
TUAREG 250	84->85	P

GARELLI	Year	A/P
TIGER 125 XR		P
TIGER 125 XRD		P

GILERA	Year	A/P
HX 125 LC	83->	P

MALAGUTI	Year	A/P
RUNNER 125 RALLY	87	P
RUNNER 125 YLC	85->	P
RUNNER 125 YPVS	86->	P

MOTO GUZZI	Year	A/P
TT 125	85->	P

TRE SOLDI	Year	A/P
REGOLARITA 80	86->	A

GF0201

STD

øt (mm): 160 (mm): 30

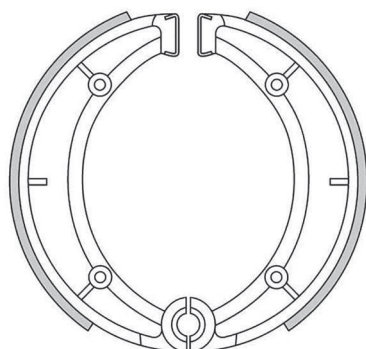

APRILIA	Year	A/P
ETX 125	84	P

...GF0201		
... segue APRILIA	Year	A/P
RED ROSE 125	87->94	P
ST 125	87->	P
STX 125	84->85	P

BETA	Year	A/P
125 SCRAMBLER	82->	P
CUSTOM 125	82->	P
CUSTOM 250	82->	P

DUCATI	Year	A/P
250 DESMO	->77	P
350 DESMO	->77	P

FANTIC	Year	A/P
SPORT 125	->84	P
SPORT 125 MK II	->84	P
STRADA 125 (FM. 4000-A)	83->	P

GARELLI	Year	A/P
TSR 125		P
TSR 125 SELF MIX		P

GILERA	Year	A/P
RV 125	83->	P
RV 125 ES	87->	P
TG1 125		P
TG2 125		P
TG3 125		P
T4 200		P
T4C 200		P
T4S 200		P

LAVERDA	Year	A/P
125	->82	P
125 (pinza Brembo)	82->	P
125 (pinza Grimeca)	82->	P
LB 125 CUSTOM		P
LB 125 STRADA		P
LB 125 UNO		P

MOTO MORINI	Year	A/P
BICILINDRO 250	79->	P
MONOCILINDRO 250	->81	P
GT 350 TURISMO	80->	P
GT (freni a tamburo) 350	79	P
SPORT 350	80	P

PUCH	Year	A/P
F5 250 REGOLARITA	83->	P
HFE 250	86->	P
MC 250 VHS W	83->	P
FS 347 REGOLARITA	->83	P
MC 496	->83	P

GF0202

STD

øt (mm): 162 (mm): 30

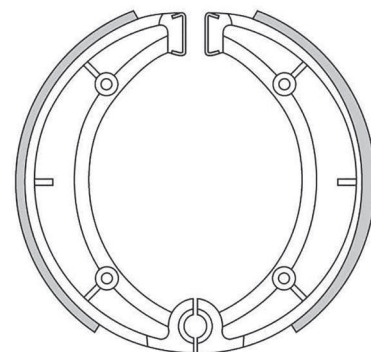

MOTO MORINI	Year	A/P
MORINI 350		P



GF0203
STD

øt (mm): 135 (mm): 25

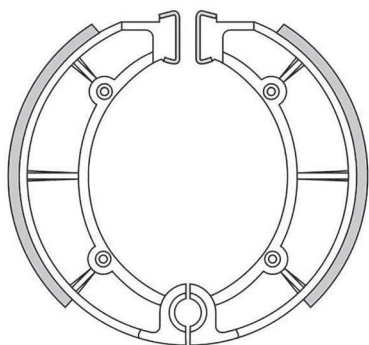

CAGIVA	Year	A/P
SST 125 LOW RIDER	83->	P
SST 125 ruota raggi	81->	P
XSST 125	->80	P
XSST 250	->80	P

GF0204
STD

øt (mm): 140 (mm): 25

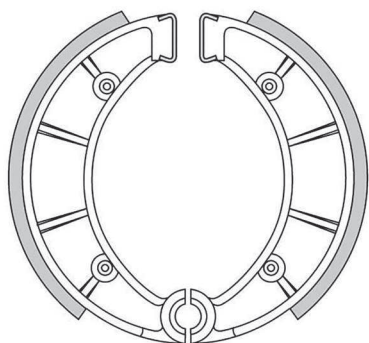

ANCILLOTTI	Year	A/P
PSV 250 MX	83->	P

APRILIA	Year	A/P
MX 125	83->88	P
RX 125	->83	P
MX 250	->82	A/P
RX 250	->82	A/P

ASPES	Year	A/P
CS 75 50 NAVAHO	76->	P
DUMA 125	00	P
HOP1 125	00	P
JUMA 125	76->	P

BETA	Year	A/P
125 6V	74->	A/P
125 SCRAMBLER	82->	A
CR 125	->81	P
CR 125	82->	A
RC 125	76->	P
RC 125 EXPORT ASPIRATO	80->	A/P
RC 125 raffreddamento ad acqua	81->	A/P
CR 250	83->	P
CR - RV 250	81->	A
GS-RV 250	->80	A/P
CR - RV 350	80->	A
GS - RV 350	80->	A

CAGIVA	Year	A/P
ALETTA 125 ELECTRA ruota integrale	88->	P
SST 125 ruota integrale	81->	P
XSST 125 ruota integrale	78->	P
MXR 250	81->	A/P

...GF0204

... segue CAGIVA	Year	A/P
RX 250	81->	A/P
MXR 400	->81	A/P
MXR 500	->81	A/P

FANTIC	Year	A/P
CROSS 80 COMPETITION	81->	P
ENDURO 80	80->	P
CABALLERO 125 REGOLARITA	81->84	P
CROSS 125 COMPETITION	80->	P
ENDURO 125	80->	P

GILERA	Year	A/P
TG1 80		P
TG2 80		P
TG3 80		P
ARCORE 125		A
E1 125		P
E1 125 COMPETIZIONE		P
GR1 125		P
ARCORE 150		P

KRAMER	Year	A/P
250		P

MOTO MORINI	Year	A/P
KANGURO 350	->83	A
CAMEL 500	->80	A
CAMEL 500	81->	P

PUCH	Year	A/P
F5 250 REGOLARITA	83->	A
MC 250 VHS W	83->	A
CROSS 347	->81	A
FS 347 REGOLARITA	->83	A
MC 496	->83	A

SWM	Year	A/P
CROSS 125	->83	A/P
ENDURO 125	->83	A/P
ENDURO 175	->83	A/P
CROSS 250	->83	A/P
ENDURO 347	->83	A/P
CROSS 440	->83	A/P
ENDURO 440	->83	A/P

GF0206
STD

øt (mm): 180 (mm): 25

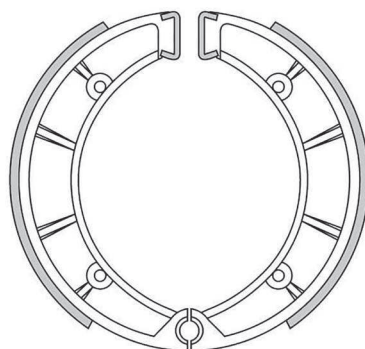

BENELLI	Year	A/P
2C 125 doppia frenata	->76	A

MOTO GUZZI	Year	A/P
TS 250	74->75	A
GTS 350	74->75	A

GF0207
STD

øt (mm): 160 (mm): 30

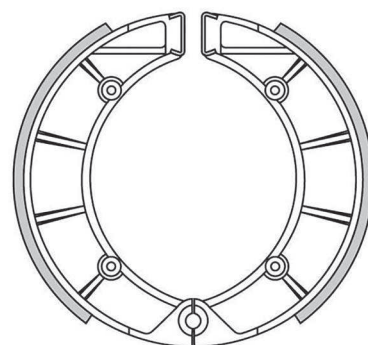

GILERA	Year	A/P
ARCORE 150		A

GF0208
STD

øt (mm): 150 (mm): 25

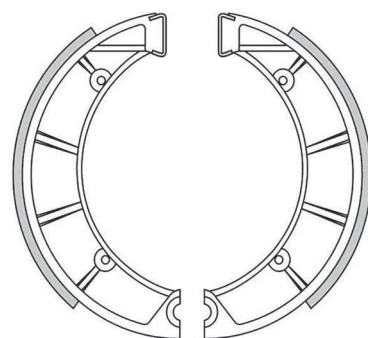

BETA	Year	A/P
CR - RV 250	81->	P
CR - RV 350	80->	P
GS - RV 350	80->	P
GS - RV 500	84->	P

MOTO MORINI	Year	A/P
KANGURO 350	->86	P
XE 350	85->	P
CAMEL 500	->80	P

PUCH	Year	A/P
CROSS 347	->81	P

GF0209
STD

øt (mm): 140 (mm): 25

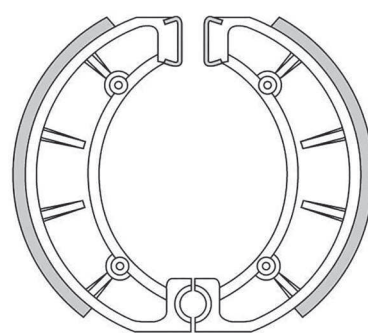

CAGIVA	Year	A/P
SST 250	->78	P

GF0210

STD | FTR | PRO

øt (mm): 90 (mm): 18

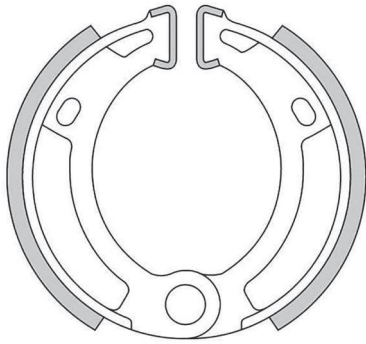

BENELLI	Year	A/P
G 2 50 ELLE	79->	A / P

GARELLI	Year	A/P
BASIC 50 (ruota lega grimeca)		A / P
FORMUNO 50 (a tel. n. 2701551)	87->	P
FORMUNO 50 (da tel. n. 2701552)	87->	P
FORMUNO 50 F1 RAID	87->	P
NOI 50 (ruota lega grimeca)		A / P
TEAM MATIC 50	88->	P
VIP 50 (ruota lega grimeca)		A / P

MALAGUTI	Year	A/P
DRIBBLING 50 all models	87->	A / P
FIFTY 50 RV	87->	A / P
FIFTY 50 RV VARIATORE / KICK	87->	A / P
FOX 50 CUSTOM	88->	A / P
GRIZZLY 50 all models	87->	A / P
GRIZZLY 50 RCX / 12	87->	P
RANOCCHIO 50 3 RUOTE	88->	A / P
RGT 50 STRADA	83->	P

PIAGGIO	Year	A/P
BOSS 50	88->	A
BRAVO 50 (ruote in lega mozzo 90mm)	87->	A
BRAVO variatore 50 (ruote in lega mozzo 90mm)	87->	A

PUCH	Year	A/P
MAXI 80 EXECUTIVE	88->	A

GF0211

STD

øt (mm): 220 (mm): 30

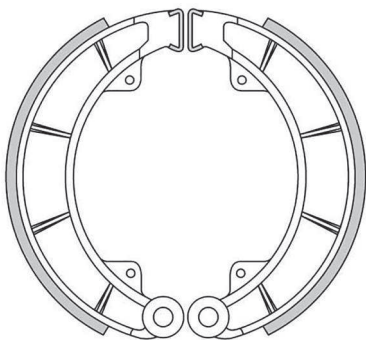

MOTO MORINI	Year	A/P
GT (freni a tamburo) 350	79	A
SPORT 350	80	A

GF0212

STD

øt (mm): 180 (mm): 35

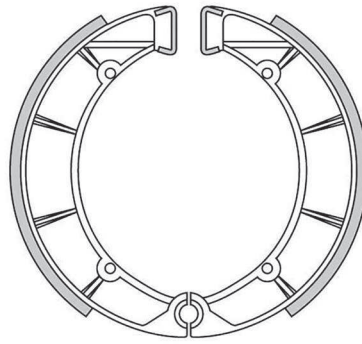

CAGIVA	Year	A/P
ALAVERDE 250	83->	P
SSX 250	82->	P
ST 250	82->	P
ALA AZZURRA 350	83->	P
ALAVERDE 350	83->	P
SX 350	83->	P

MOTO MORINI	Year	A/P
GT 350	76->81	P
SPORT 350	81	P

GF0213

STD

øt (mm): 160 (mm): 25

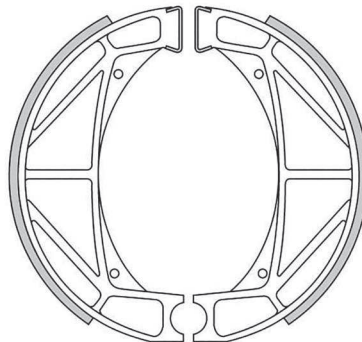

CAGIVA	Year	A/P
ALA BLU 250	83->	P
ALA ROSSA 250	83->	P
SST 250	80->	P
SST 250 ruota integrale	->82	P
SX 250	->81	A / P
ALA BLU 350	83->	P
ALA ROSSA 350	83->	P
SST 350	->78	A / P
SX 350	->82	A / P

GF0214

STD

øt (mm): 140 (mm): 25

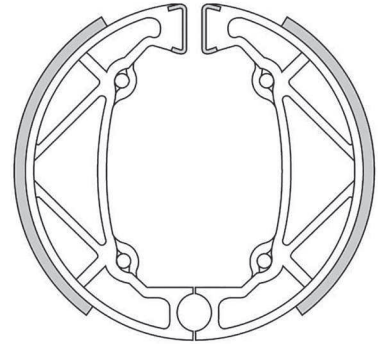

GILERA	Year	A/P
ARIZONA 125	83->	P
ER 125	87->	P
RC 125 RALLY	87->88	P
RRT 125 NEBRASKA	87->	P
RTX 125		P
RX 125	84->	P
RX 125 ARIZONA HAWK	86->	P
ARIZONA HAWK 200	86->	P
ER 200	87->	P
RTX 200	86->	P
RX 200	85->	P
RX 200 ARIZONA HAWK	86->	P

GF0215 (2 pz)

STD

øt (mm): 150 (mm): 18

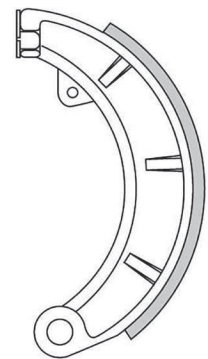

PIAGGIO	Year	A/P
VESPINO 50	->79	P

GF0218

STD

øt (mm): 124 (mm): 25

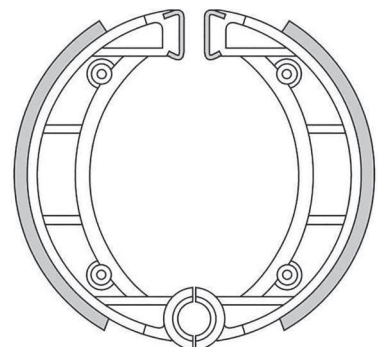

BENELLI	Year	A/P
S 50	81->87	P
S 50 (tutti i modelli)	87->	P
S 50 LUSSO	81->87	P

FIGURATO GANASCE CON APPLICAZIONI | BRAKE SHOES DRAWINGS AND APPLICATIONS | DESSINS MÂCHOIRES DE FREIN AVEC APPLICATIONS | DISEÑOS MORDAZAS CON RELACIÓN | ZEICHNUNGEN VON BREMSBACKEN MIT VERWENDUNGSLISTE



...GF0218

ITALJET	Year	A/P
T 50		A/P
T 100		A/P
RANGER 125	85->	A/P
SKIPPER 125	85->	A/P
T 125		A/P
T 250		A/P
T250 PIUMA	85->	A/P
BOSS 350 4T		A/P
BOSS 350 ENDURO		P
CUSTOM 350	85->	A
CX 350	85->	P
EXPLORER 350	85->	A/P
H&H 350 2T		A/P
SCOTT 350 4T		A/P
T350 PIUMA	85->	A/P

GF0219
STD

øt (mm): 125 (mm): 22

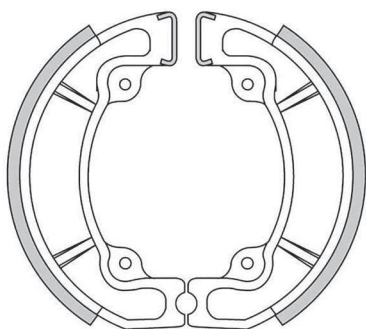

CAGIVA	Year	A/P
ALETTA 125 ELECTRA	->83	P
ELEFANT 125	->83	P
WSXT 125 ALETTA ROSSA	83->	P

GILERA	Year	A/P
RALLY 50	87->	P
RRT 125 NEBRASKA (ruote tubles)	87->	P

GF0220
STD

øt (mm): 118 (mm): 24

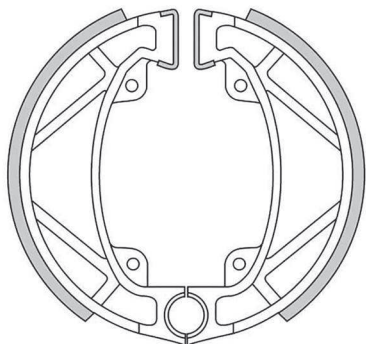

APRILIA	Year	A/P
ET 50	84->86	P
ETX 50	86->	P
TUAREG 50	84->86	P
TUAREG 50 (freno a disco)	84->86	P

FANTIC	Year	A/P
OASIS 50.1 K.S.	87->	P
OASIS 50.1 RALLY	86->	P
RAIDER 50	81->85	P
RAIDER 50,0,1	86->	P
TRAILMATIC 50 (FM. 283)	83->	A/P

...GF0220

... segue FANTIC	Year	A/P
TRIAL 50.1 (FM.268)	86	P
TRIAL 50 II mozzi conici	83->84	A/P
TRIAL 50 JUNIOR	87	A

MALAGUTI	Year	A/P
RCX-W 50 ENDURO	83->	P
SAHIB 50 ENDURO	83->	P

TM	Year	A/P
all models 80	->85	P
all models 125	->89	P

GF0221
STD
FTR

øt (mm): 125 (mm): 25

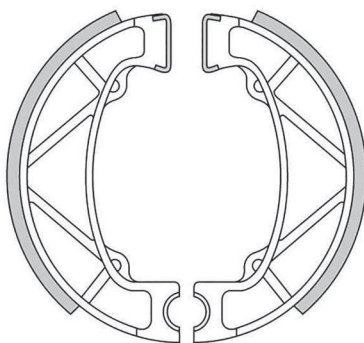

BETA	Year	A/P
TR 32 240 (mozzo ant autocentrante)	84->85	A

FANTIC	Year	A/P
RAIDER 125	83->	P
RAIDER 125 LC	83->	P
TRIAL 240 SEVEN DAYS (FM. 289)	86	A
TRIAL 300 (FM. 403)	84	A

GF0222
STD
FTR

øt (mm): 125 (mm): 25

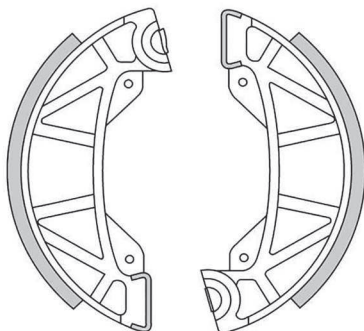

ACCOSSATO	Year	A/P
CE 80 CROSS H20	84->	A
CE 80 ENDURO H20	84->	A
CE 125 CROSS H20	84->	A
CE 125 ENDURO H20	84->	A

APRILIA	Year	A/P
TUAREG 125	84->85	A
MX 250	84->	A/P
RX 250	84->85	A/P

TRE SOLDI	Year	A/P
REGOLARITA 80	86->	P

GF0223
STD

øt (mm): 118 (mm): 24

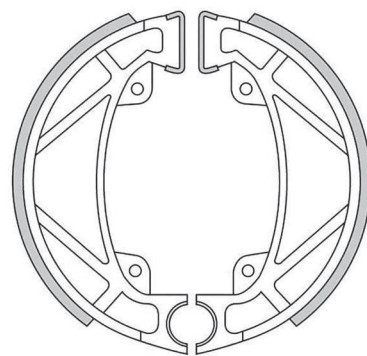

BETA	Year	A/P
RX 50	84->	P
RX 125	84->	P

GF0224
STD

øt (mm): 150 (mm): 24

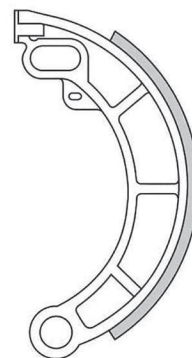

FANTIC	Year	A/P
TRIAL 50 JUNIOR	87	P

PIAGGIO	Year	A/P
VESPA 50 FL2 AUTOMATICA	90->91	P
VESPA 50 PK AUTOMATICA (VA51T)	84->89	P
VESPA 50 PK AUTOMATICA (VAM1T)	84->89	P
VESPA 50 PK XL PLURIMATIC	85->90	P
VESPA 125 PK AUTOMATICA	84->	P

GF0225
STD
FTR

øt (mm): 125 (mm): 26

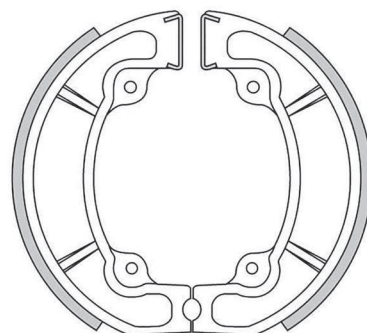

CAGIVA	Year	A/P
ALETTA 125 ELECTRA	84->	P
ELEFANT 125	84	P

GF0226

STD

øt (mm): 130 (mm): 30

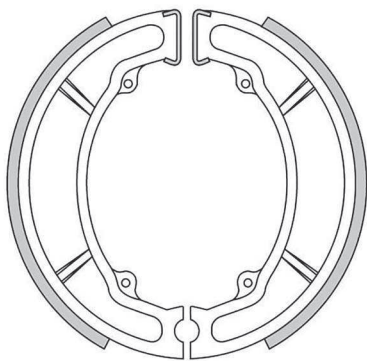

GF0229

STD

øt (mm): 160 (mm): 30

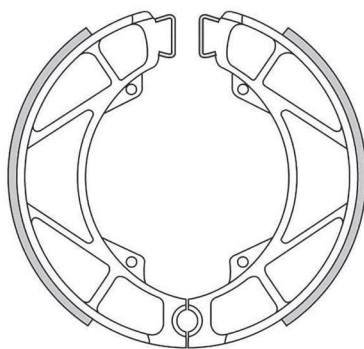

GF0234

STD

FTR

øt (mm): 190 (mm): 18

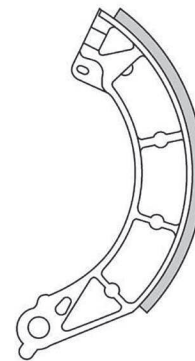

CAGIVA	Year	A/P
DAKAR 125	85->	P
ELEFANT 125	85->86	P
ELEFANTRE 125	87->	P
ELEFANT 200	85	P
ELEFANT 200 A.E.	86->	P
T4 350 R - ER	87->	P
T4 500 E - ER	87->	P

FANTIC	Year	A/P
SPORT 125 HP1 (FM.265)	85->	P
SPORT 125 MK II (f.a.tel.1706338)	85->	P

PIAGGIO	Year	A/P
SUPERBRAVO 50 3 Marce	87->	P

GF0227

STD

øt (mm): 140 (mm): 25

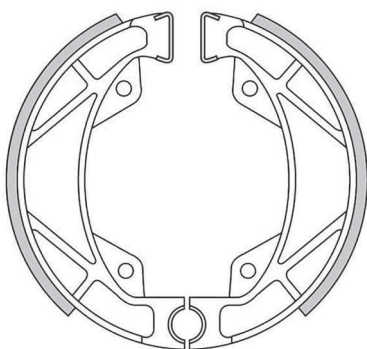

GF0232

STD

øt (mm): 130 (mm): 25

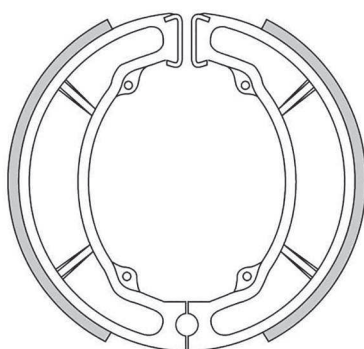

GF0235

STD

FTR

øt (mm): 130 (mm): 30

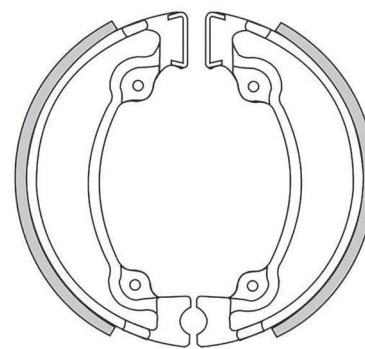

FANTIC	Year	A/P
RAIDER 250 (FM. 259)	85->	P

GILERA	Year	A/P
DAKOTA 350	86->	P
ER 350	87->	P
ER 500	87->	P

CAGIVA	Year	A/P
WMX 125 CROSS	86->	P
WMX 250 CROSS	87->	P

CAGIVA	Year	A/P
WMX 500	84->	P

GF0228

STD

øt (mm): 104 (mm): 22

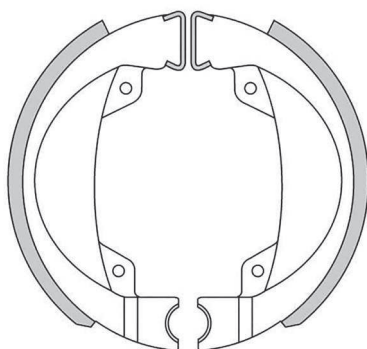

GF0233

STD

øt (mm): 125 (mm): 25

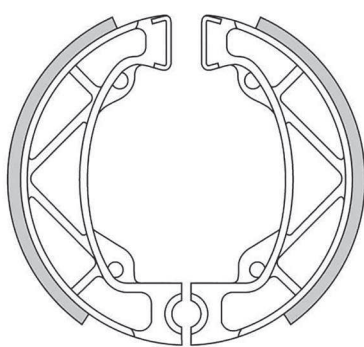

GF0236

STD

øt (mm): 140 (mm): 25

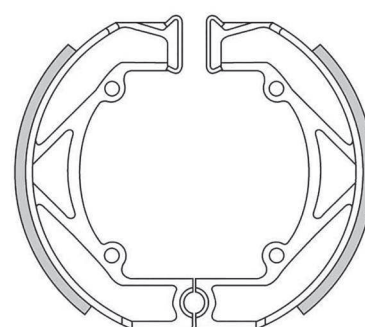

GARELLI	Year	A/P
FORMUNO 50 (a tel.n. 2701551)	87->	A

APRILIA	Year	A/P
ETX 125	85->97	P
RX 125	86->89	P
TREND GO WEST 125	87->	P
TUAREG 125	84->85	P
TUAREG 125 RALLY	86->88	P
RX 250	86->	P
TUAREG 250 RALLY	86->	P

BENELLI	Year	A/P
S 125 SCOOTER		A / P

FIGURATO GANASCE CON APPLICAZIONI | BRAKE SHOES DRAWINGS AND APPLICATIONS | DESSINS MÂCHOIRES DE FREIN AVEC APPLICATIONS | DISEÑOS MORDAZAS CON RELACIÓN | ZEICHNUNGEN VON BREMSBACKEN MIT VERWENDUNGSLISTE



GF0242/3 (6 pz)
STD

øt (mm): 190 (mm): 47

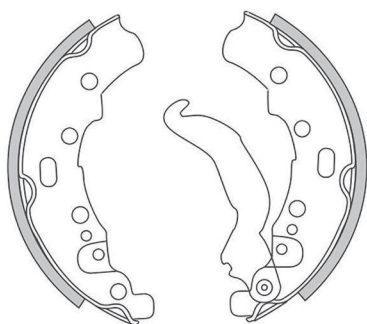

PIAGGIO	Year	A/P
APE TM 220	09->16	A
APE TM 220 P 602	82->83	A
APE TM 220 P 703 / P 703 V / FL2	84->07	A
APE CAR 420 DIESEL	86->96	A
APE CAR 420 MAX DIESEL 9 q.li	86->96	A
APE MP 420 601 CLASSIC	06->07	A
APE TM 420 DIESEL LCS	05->12	A
APE TM 420 P 703 / P 703 V DIESEL	87->04	A

GF0244
STD

øt (mm): 118 (mm): 24

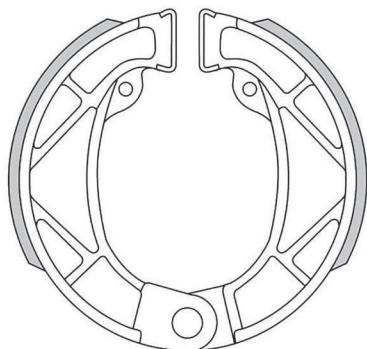

APRILIA	Year	A/P
CLASSIC 50	92->01	P
RED ROSE 50	92->	P
CLASSIC 80	93	P

FANTIC	Year	A/P
OASIS 50.1 KICK	87->	P
TRIAL 50.1 H2O	87	P

GF0245
STD | FTR

øt (mm): 104 (mm): 22

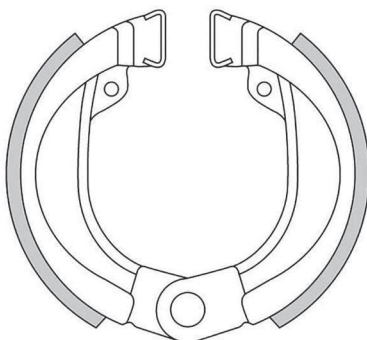

GARELLI	Year	A/P
FORMUNO 50 (da tel. n 2701552)	87->	A

PEUGEOT	Year	A/P
FOX 50	96->	A

GF0246
STD | FTR

øt (mm): 90 (mm): 20

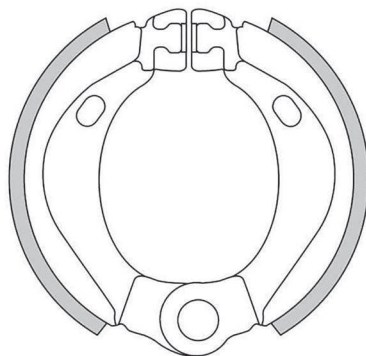

GARELLI	Year	A/P
TEAM MATIC 50	88->	A

GF0247
STD

øt (mm): 140 (mm): 20

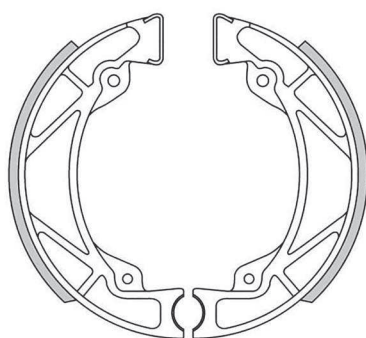

GILERA	Year	A/P
BULLIT 50	90->	P

GF0249
STD | FTR

øt (mm): 170 (mm): 25

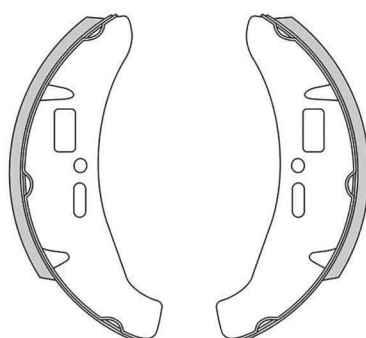

PIAGGIO	Year	A/P
COSA 125 CL / CL2	88->91	P
COSA 2 125	91->97	P
COSA 150 CL / CLX	88->91	P
COSA 2 150	91->97	P
COSA 200	89->91	P
COSA 1 200	89->91	P
COSA 2 200	91->97	P

GF0250
STD | FTR

øt (mm): 170 (mm): 25

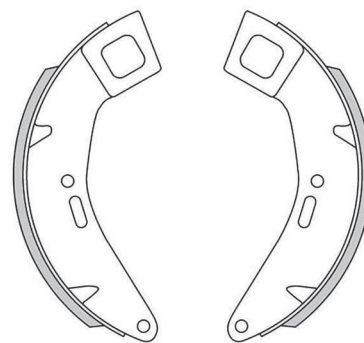

PIAGGIO	Year	A/P
COSA 125 CL / CL2	88->91	A
COSA 2 125	91->97	A
COSA 150 CL / CLX	88->91	A
COSA 2 150	91->97	A
COSA 200	89->91	A
COSA 1 200	89->91	A
COSA 2 200	91->97	A

GF0251
STD

øt (mm): 110 (mm): 25

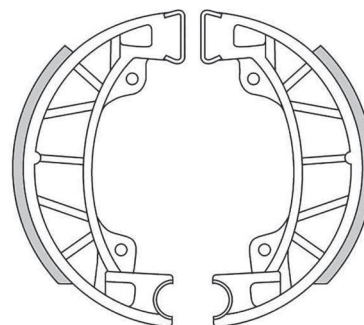

PIAGGIO	Year	A/P
SFERA 50	91->94	A
SFERA 80	94->	A

GF0252
STD | PRO

øt (mm): 100 (mm): 20

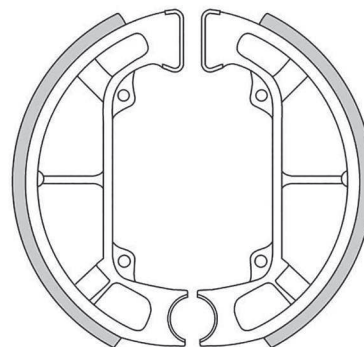

GILERA	Year	A/P
EASY MOVING 50	95->	P
STORM 50	94->95	P
TYPHOON 50	93->95	P
TYPHOON 80	93->	P

PIAGGIO	Year	A/P
FREE 50 (ruote in lega)	96->	P
NRG 50	94->95	P

...GF0252		
... segue PIAGGIO	Year	A/P
NTT 50	->95	P
QUARTZ 50	92->	P
SFERA 50	91->94	P
ZIP 50	92->93	P
SFERA 80	94->	P

GF0253 STD

øt (mm): 110 (mm): 25

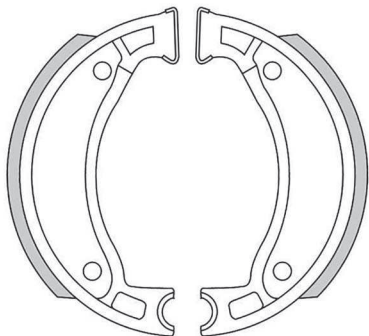

ITALJET	Year	A/P
BAZOOKA 1 50	91	P
BAZOOKA 2 50	92->	P
PISTA 50	92->	P
REPORTER 50	90->	P
SCOOP 50	93->	P
YANKEE 8 50	94->	P

GF0254 STD

øt (mm): 110 (mm): 22

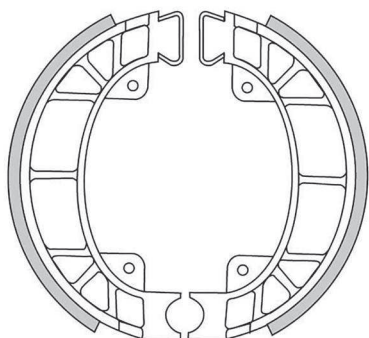

PIAGGIO	Year	A/P
SCATTO 50	90->	A/P
ZUM 50	91->	A/P

GF0255 STD | PRO

øt (mm): 110 (mm): 25

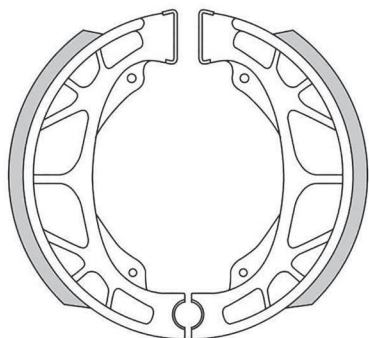

APRILIA	Year	A/P
AMICO 50	90->91	A/P
AMICO 50 all models	92->96	P

...GF0255		
... segue APRILIA	Year	A/P
GULLIVER 50	95->98	P
RALLY 50	95	P
SCARABEO 50	93->97	P
SONIC 50 GP	97->	P
SONIC 50 SPICE	97->	P
SR 50 all models	93->95	P
SCARABEO 70	94	P

ATALA	Year	A/P
CAROSSELLO 50	97->	P
BENELLI	Year	A/P
491 50 all models	97->	P
PEPE 50	99->04	P
BETA	Year	A/P
ARK 50	->95	P
CH 50	96->	P
CHRONO 50	92->94	P
CHRONO 50 ruota da 13	94->	P
CRONO 50 502	97->	P
QUADRA 50	95->96	P
TEMPO 50	92->98	P
TEMPO 50 13	00	P
TEMPO 50 16	00	P

BS VILLA	Year	A/P
AX 50	93->	P
DIO GP 50	93->	P
DIO SP 50	93->	P
GZ 50	93->	P

CAGIVA	Year	A/P
CITY 50	92->94	P

DAELIM	Year	A/P
NS 125 II	00->	P

KTM	Year	A/P
CHRONO 50 SCOOTER	94->	P
GO 50 SCOOTER	94->	P

MALAGUTI	Year	A/P
CENTRO 50	93->94	P
CENTRO 50 SL	94->98	P
CIAK 50	99->00	P
CIAK 50 MASTER	04->05	P
CIAK 50 MASTER EURO 2	06	P
CIAK 50 MONO EURO 2,3	03	P
F 10 50	92->98	P
F 10 50 RESTYLING	01->06	P
F 12 50 PHANTOM	94->98	P
F 12 50 PHANTOM LC	94->98	P
F 15 50 FIREFOX	96->97	P
YESTERDAY 50	98->	P

PEUGEOT	Year	A/P
SV 50T (forcella telescopica)	93->	P

SYM	Year	A/P
CINDERELLA 50	99->00	P
CITY HOPPER 50	99->	P
FANCY 50	95->	P
FIDDLE 50	99->	A
JUNGLE 50	96->	P
MASK 50	00->	P
MASK 50 LC	00->	P
RED DEVIL 50	99->	P
SUPER FANCY 50	95->00	P
CINDERELLA 100	99->00	P
SUPER FANCY 100	95->98	P
SUPER DUKE 125	99->02	P

YAMAHA	Year	A/P
AXIS 50 PROFOOT	94->	P
AXIS 50 YA	93->	P
JOG 50 Z (Italia)	93->	P
TRUNK 50	94->	P

GF0256 STD

øt (mm): 110 (mm): 25

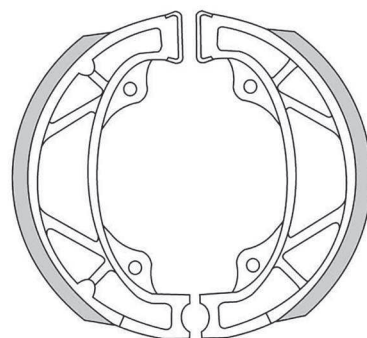

ITALJET	Year	A/P
BAZOOKA 1 50	91	A
REPORTER 50	90->	A

RAPIDO	Year	A/P
SCRENNA 50		A

GF0257 STD

øt (mm): 104 (mm): 20

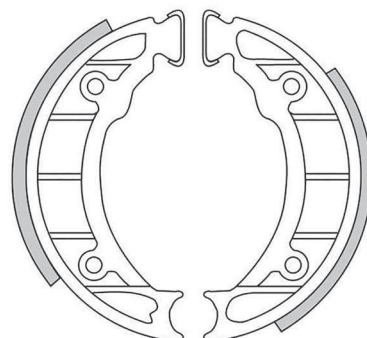

PIAGGIO	Year	A/P
FREE 50	93->95	P
FREE 50 (ruote in lega)	96->	A
ZIP 50	92->93	A

GF0258 (4 pz) STD

øt (mm): 190 (mm): 47

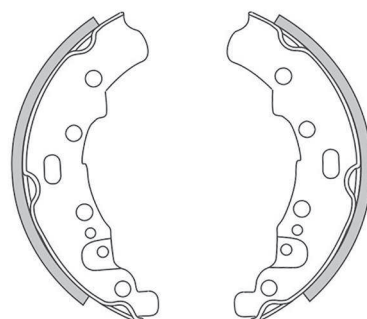

PIAGGIO	Year	A/P
APE POKER 420 BENZINA	93	A
APE POKER 420 DIESEL	93->97	A
QUARGO 750 DIESEL	04->06	A



GF0259 (4 pz)
STD

øt (mm): 190 (mm): 47

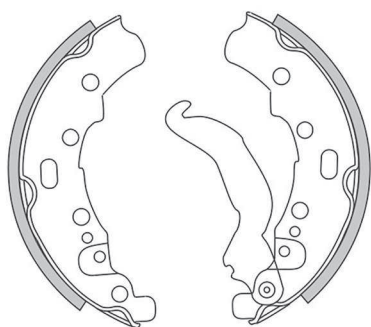

PIAGGIO	Year	A/P
APE POKER 420 BENZINA	93	P
APE POKER 420 DIESEL	93->97	P
QUARGO 500	05->17	P
QUARGO 750 DIESEL	04->06	P

GF0260
STD

øt (mm): 80 (mm): 16

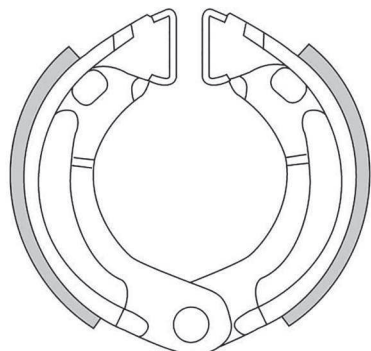

PIAGGIO	Year	A/P
P1 50	94->	A/P

PUCH	Year	A/P
RADICAL 50	94->	A/P

GF0261
STD | FTR | PRO

øt (mm): 110 (mm): 25

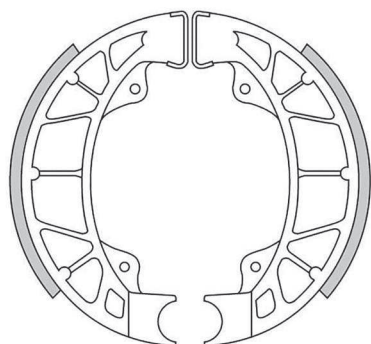

APRILIA	Year	A/P
SPORT CITY 50 ONE 2T	08->10	P
SPORT CITY 50 ONE 4T	08->10	P

GILERA	Year	A/P
RUNNER 50	96->	P
STALKER 50	05->08	P
STALKER 50 (post freno a disco)	97->04	P
STALKER 50 NAKED	08->	P

...GF0261

... segue GILERA	Year	A/P
STALKER 50 SPECIAL EDITION	07->08	P
STORM 50 EURO 2	07	P
TYPHOON 125	95->98	P
TYPHOON 125 X - XR	99->00	P

PIAGGIO

Year	A/P
VELOFAX 50	96->
VESPA 50 ET2	97->
VESPA 50 ET2 4T	00->01
VESPA 50 ET2 INIEZIONE	99->
VESPA 50 ET4	99->
VESPA 50 LX 2T	05->
VESPA 50 LX 2T TOURING	10
VESPA 50 LX 4T	05->
VESPA 50 LX 4T 4V TOURING	10
VESPA 50 PRIMAVERA 2T	13->16
VESPA 50 PRIMAVERA 4T 4V	13->
VESPA 50 SPRINT 2T	14->16
VESPA 50 SPRINT 4T 4V	14->
ZIP 50	99->
ZIP 50 4T	00->04
ZIP 50 CATALYZED	00->
ZIP 50 FAST RIDER	95->
ZIP 50 HT	00->
ZIP 50 RST	96->97
ZIP 50 SP	96->
ZIP 100 4T	06->10

HEXAGON 125	94->97
SFERA 125	95->
SFERA 125 4T	95->97
SKIPPER 125	93->99
VESPA 125 ET4	96->02
VESPA 125 LX	05->06
VESPA 125 LX EURO 3	06->07
VESPA 125 LX IE EURO3	09->10
VESPA 125 LX TOURING	10->
VESPA 125 LXV 4T EURO 3	06->09
VESPA 125 LXV 4T NAVY EURO 3	07->08
VESPA 125 LXV IE 4T	10->13
VESPA 125 S 4T IE & COLLEGE	09->10
ZIP 125 4T	00->02
HEXAGON 150	94->99
HEXAGON 150 LX	98->
SKIPPER 150	93->99
VESPA 150 ET4	96->02
VESPA 150 LX	05->06
VESPA 150 LX EURO 3	06->07
VESPA 150 LX IE EURO 3	09->11
VESPA 150 LX TOURING	10->
VESPA 150 S 4T IE & COLLEGE	09->10

GF0262
STD

øt (mm): 125 (mm): 25

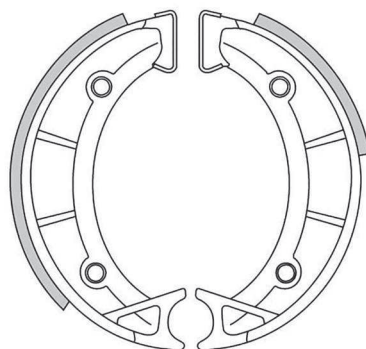

APRILIA	Year	A/P
SCARABEO 50	93	A

GF0263
STD | PRO

øt (mm): 100 (mm): 20

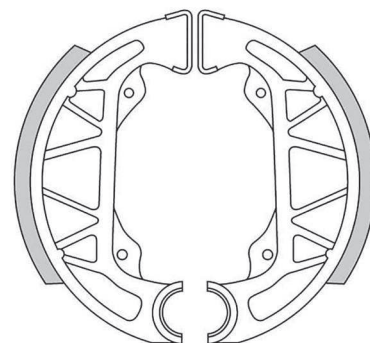

GILERA	Year	A/P
TYPHOON 50	96->	P

PIAGGIO	Year	A/P
FREE 50	96->	P
NRG 50	96->	P
NRG 50 MC2	96->	P
NTT 50	96->	P
SFERA 50 RST	95->	P
ZIP 50 FAST RIDER	93->94	P

GF0264
STD

øt (mm): 110 (mm): 25

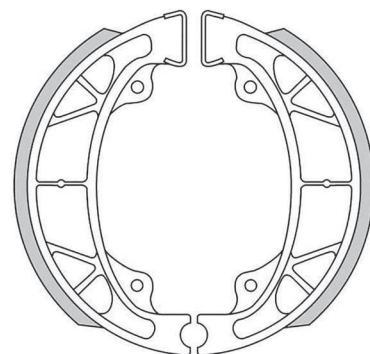

MALAGUTI	Year	A/P
CR1 50 CROSSER	95->98	P

GF0265
STD

øt (mm): 150 (mm): 18

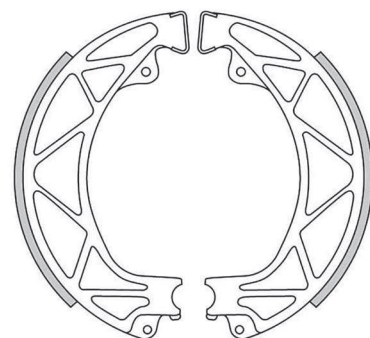

PIAGGIO	Year	A/P
VELOFAX 50	96->	P

GF0266

STD

øt (mm): 105 (mm): 22

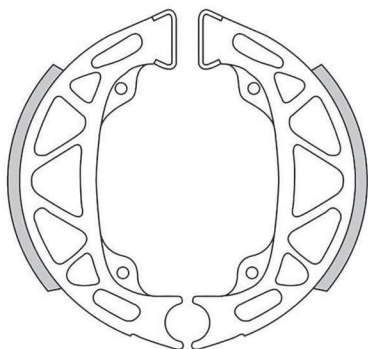

PIAGGIO	Year	A/P
CIAO 50 MIX	97->	A
SI 50 MIX	97->	A
ZIP 50	99->	A
ZIP 50 RST	98->99	P

GF0268

STD | PRO

øt (mm): 140 (mm): 25

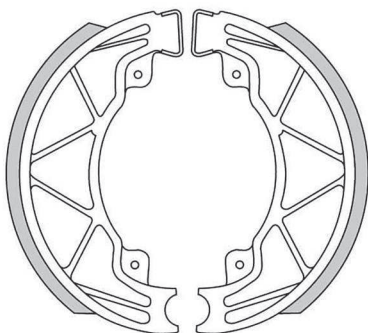

APRILIA	Year	A/P
SCARABEO 50 2T	10->12	P
SCARABEO 50 4T 4V	10->12	P
SCARABEO 100 4T	01->04	P
SCARABEO 100 4T RESTYLING	06->12	P
SCARABEO 100 NET	10->	P
HABANA 125	98->	P
MOJTO 125 all models	99->04	P
SPORT CITY 125 ONE 4T EURO 3	08->10	P
SR 125	99->	P
SR 150	99->	P

DERBI	Year	A/P
BOULEVARD 125	02->04	P
BOULEVARD 125 S	07->	P
BOULEVARD 150	02->04	P
BOULEVARD 200	05->	P

GILERA	Year	A/P
RUNNER 125	97->99	P
RUNNER 180	97->98	P

MALAGUTI	Year	A/P
CENTRO 50 4T	08	P
CENTRO 50 SL 4T	10	P
CIAK 50 MASTER 4T	05->06	P

PIAGGIO	Year	A/P
FLY 50 2T	05->	P
FLY 50 4T	05->10	P
LIBERTY 50 2T	97->	P
LIBERTY 50 4T	00->01	P
LIBERTY 50 IGET 4T 3V	16	P
LIBERTY 50 IGET 4T 3V IE	15->17	P
FLY 100 4T	06->08	P
FREE 100	01->	P
FLY 125	05->08	P
HEXAGON 125 LX	98->	P

...GF0268

... segue PIAGGIO	Year	A/P
LIBERTY 125	98->02	P
LIBERTY 125 4T	06->07	P
LIBERTY 125 4T EURO3	07->08	P
LIBERTY 125 4TS PORT EURO3	06->08	P
LIBERTY 125 IGET 4T 3V IE	15->18	P
LIBERTY 125 RST	04->05	P
LIBERTY 125 RST PTT	05->11	P
LIBERTY 125 SPORT	06	P
SKIPPER 125 4T	98->	P
VESPA 125 LX PRIMAVERA 4T 3V IGET ABS	13->16	P
VESPA 125 PRIMAVERA 4T 3V IE	13->16	P
VESPA 125 SPRINT IGET 4T 3V ABS	16->17	P
X8 125 STREET EURO 3	06->	P
FLY 150	05->07	P
FLY 150 EURO 3	08->10	P
LIBERTY 150 4T	08	P
LIBERTY 150 4T SPORT	08	P
LIBERTY 150 IGET 4T 3V IE	15->18	P
LIBERTY 150 LE	00->02	P
SKIPPER 150 4T	00->02	P
VESPA 150 PRIMAVERA 4T 3V	13->16	P
VESPA 150 PRIMAVERA 4T 3V IGET ABS	16	P
X8 150 STREET EURO 3	06->	P
HEXAGON 180 LX	98->	P
LIBERTY 200	06	P
LIBERTY 200 4T EURO3	07->08	P
LIBERTY 200 4T SPORT EURO 3	06->07	P
LIBERTY 200 RST	04->05	P
LIBERTY 200 SPORT	06	P

GF1002

STD

øt (mm): 90 (mm): 20

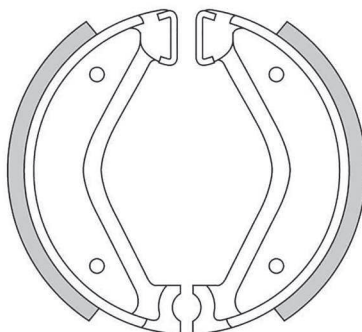

PUCH	Year	A/P
MS 50		A/P
MS 50 L	88->	A/P

GF1022

STD

øt (mm): 105 (mm): 25

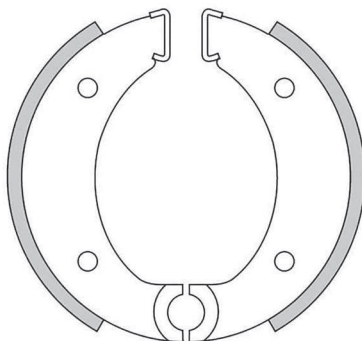

PUCH	Year	A/P
DS 50		A/P
DZS 50		A/P
ROLLER DS 50 K		A/P
VS 50		A/P

...GF1022

TOMOS	Year	A/P
MOFAS 50 MOPEDS		A/P

GF1043

STD | FTR | PRO

øt (mm): 110 (mm): 25

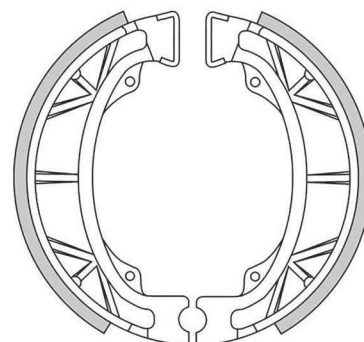

BENELLI	Year	A/P
CHRONO 50	92->93	P

E-TON	Year	A/P
LXL / CLX 150 CHALLENGER	03->05	A
RXL 150 VIPER	05->06	A
ST EXL 150 YUKON	05->	A

HERCULES	Year	A/P
GIPSY 50	93->	P
LIMBO 50	93->	P
SAMBA SR 50	93->	A/P
SAMBA SR 80	93->	P
SAMBA SR 125	93->	P

HONDA	Year	A/P
C 50	75->02	A/P
CB 50 J all models	81->	A/P
CF 50 CHALY	79->	A/P
DAX 50	93->	A/P
MONKEY 50	88->	P
NH 50 LEAD	->93	A
PK 50 WALLAROO DX - STD	90->	P
QA 50 K1/3	87->	A/P
SFX 50	95->	P
SH 50	84->87	A
SH 50 FIFTY	96->	P
SJ 50 BALI	93->	P
SKY 50	97->	P
SKY 50 VETRO	00->	P
SS 50 ZB2	77->80	P
SS 50 ZK2	75->77	A/P
ST 50	78->93	A/P
VT 50 SHADOW	98->	P

C 70 all models	75->85	A/P
CF 70 C	77->78	A/P
DAX ST 70	78->	A/P
NF 75	79->	A/P
SA 75 VISION	88->	A
SH 75 SCOOPY	88->	A
XR 75	79->	A
YUPY 75	91->	P
CH 80 ELITE	85->90	A
MBX 80 (ESPANA)	84->	P
NH 80 LEAD	83->84	A
SH 80	84->	A
SH 80 SCOOPY	88->	A
C 90	75->81	A/P
EZ 90 CUB	90	A/P
LEAD 90 A		A
LEAD 90 L - M		A
SRX 90 SHADOW	99->	P
TRX 90	93->11	A
VT 90 SHADOW	98->	P
H 100	84->92	A/P
SH 100	97->	P
SJ 100 BALI - EX	98->	P

FIGURATO GANASCE CON APPLICAZIONI | BRAKE SHOES DRAWINGS AND APPLICATIONS | DESSINS MÂCHOIRES DE FREIN AVEC APPLICATIONS |
DISEÑOS MORDAZAS CON RELACIÓN | ZEICHNUNGEN VON BREMSBACKEN MIT VERWENDUNGSLISTE



...GF1043		
... segue HONDA	Year	A/P
SUPRA 100	97->98	A / P
CT 110	80->88	A
ANF 125 I INNOVA	07->	P
ANF 125 INNOVA	03->11	P
ATC 125 M	84->85	A
CG 125	85->97	P
CG 125 all models	77->84	A / P
CH 125 SPACY	83	A / P
MTX 125 R	87->95	P
NH 125 H	83	A / P
NH 125 LEAD	83->87	A / P
NS 125 F all models	86->87	P
NSR 125	88	P
NX 125 (ITALY)	90->	P
TRX 125 FOURTRAX	85->87	A
TRX 125 J	88	A
XL 125	79	A
ATC 185	80->83	A
ATC 200	81->83	A
ATC 200 M	84->85	A
ATC 200 S	84->86	A / P
MTX 200 R	87->	P
XL 200 R	85->	P
XLR 250 R	85->88	P
HONDA ITALIA	Year	A/P
CB 125	79->	P
DT 125	87->	P
MTX 125 R	86->	P
MTX 125 RALLY SPORT	88->	P
NS 125 F	85->	P
NS 125 R SUPER SPORT	87->	P
XL 125	79->	A / P
XL 125 L PARIS DAKAR	85->	P
XL 125 PARIS DAKAR	84->85	A / P
XL 125 R2	87->	P
XL 200 L	85->	P
XL 200 L PARIS DAKAR	87->	P
XL 200 R	83->	A / P
XL 200 R PARIS DAKAR	84->	A / P
XL 200 R2	87->	P
KYMCO	Year	A/P
AGILITY 50	05->08	P
AGILITY 50 4T R 10	06->14	P
AGILITY 50 4T R 12	07->15	P
AGILITY 50 RS NAKED 2T	10->15	P
CALYPSO 50	97->99	P
COBRA 50 CROSS	99->06	P
COBRA 50 EXCLUSIVE	01->04	P
COBRA 50 RACER	99->06	P
CX 50	94->97	A
DINK 50	97	P
DJ 50	94->02	A / P
DJ 50 REFINED	99->02	A / P
DJW 50	94->97	A
DJX 50	91->92	A
DJY 50	93->06	A
FILLY 50	98->03	A / P
FILLY 50 LX	01->06	P
HEROISM 50	95->99	P
K 12 50	95->00	P
KB 50	94->00	P
LIKE 50 2T	09->	P
LIKE 50 4T	09->	P
MANBOY 50	95->00	P
MXER 50	03->07	A
MXU 50	05->10	A
MXU 50 SR	06->	A
SENTO 50	08->10	P
SPACER 50	99->06	P
TB 50	00->	P
TOP BOY 50 ON / OFF ROAD	96->05	P
TOP BOY 50 RACER / CROSS	01->05	P
VITALITY 50	04->09	P
VITALITY 50 4T	04->09	P
YAGER 50	01->07	P

...GF1043		
... segue KYMCO	Year	A/P
YUP 50	01	P
FILLY 80	99->02	A / P
MANBOY 90	96->01	P
COBRA 100 RACER	99->03	P
KB 100	99->00	P
TOP BOY 100	97->	P
TOP BOY 100 ON / OFF ROAD	99->00	P
B 125 FREEWAY	93->95	P
D2 125 FREEWAY	95->	A / P
FREEWAY 125	97->	A / P
HEROISM 125	95->97	P
MXER 125	03->07	A
FREEWAY 150	95->96	P
FREEWAY 150	97->	A
MXER 150	03->	A
MXU 150	05->	A
PEUGEOT	Year	A/P
BUXY 50	94->	P
BUXY 50 RS	94->	P
ELYSEO 50	98->01	P
FOX 50	96->	P
LOOKOR 50	01->05	P
LUDIX 50	04->	A / P
LUDIX 50 (disk)	04->	P
METROPOLIS 50		A
SC 50		A
SPEEDAKE 50	95->	P
SPEEDFIGHT 50 (Pinza Brembo)	96->	P
SPEEDFIGHT 50 M (Pinza AJP)	97->98	P
SPEEDFIGHT 50 M (Pinza Heng-Tong)	97->	P
SPEEDFIGHT 3 50 AC	10->14	P
SPEEDFIGHT 4 50 AC	15->	P
SQUAB 50	96->	P
SV 50 APS SYSTEM	91	A / P
SV 50 GEO	92	P
SV 50 GEO (all models)	93->	P
SV 50 ROLLAND GARROS	93->	P
SV 50 SPORT	93->	P
SX 50		A
TREKKER 50 ROAD	97->	P
TWEET 50	10->13	P
V-CLICK 50	08->	P
VIVACITY 50	98->	P
VIVACITY 50 (forcelle Paioli)	98->07	P
X FIGHT 50 M	00->	P
ZENITH 50	94->95	P
SC 75		A
SC 75		A
METROPOLIS 80		A
SC 80		A
SV 80 EXECUTIVE	96->	P
SX 80		A
ELYSEO 100	98->01	P
TREKKER 100	98->	P
VIVACITY 100	98->01	P
X FIGHT 100 M	00->	P
LUDIX 125	04->	P
SV 125 C EXECUTIVE	96->	P
SV 125 EXECUTIVE	94->	P
SV 125 GEO	91->92	P
TWEET 125	10->13	P
TWEET 150	10->13	P
PGO	Year	A/P
STAR 50	->93	A
STAR 2 50	94->	A
BIG MAX 80		A
STAR 80	90->	A
SYM	Year	A/P
ALPHA 50	95->	P
JET 50	95->	P
ATTILA 125	95->98	P
SUPER DUKE 150	96->98	P
YAMAHA	Year	A/P
FLY ONE 50	92->	P
FLY ONE 150 XC	90->95	P

GF1044 | STD | FTR

øt (mm): 160 (mm): 30

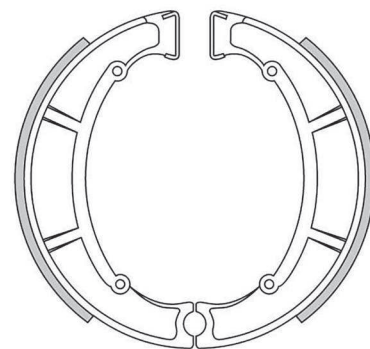

MAICO	Year	A/P
GSE 250 ALPHA-E	->83	P
LINK 250	->83	P
MX 250 TWIN	->83	P
400	->83	P
MX 490 LINK	->83	P
MX 490 TWIN	->83	P

GF1075 | STD | FTR

øt (mm): 138 (mm): 25

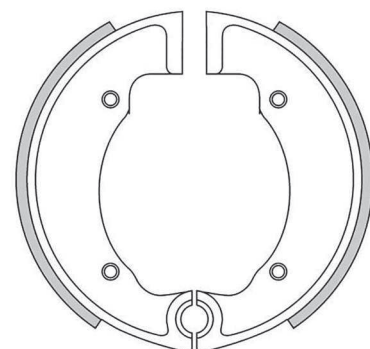

BSA	Year	A/P
BANTAM D7 175		A / P

TRIUMPH	Year	A/P
CUB 500		A / P

GF1076 | STD

øt (mm): 127 (mm): 16

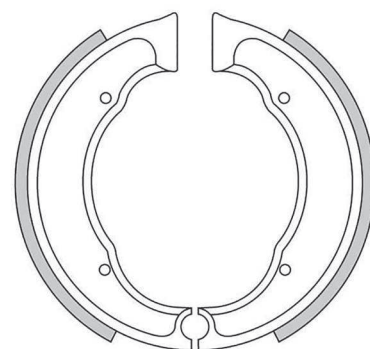

BSA	Year	A/P
BANTAM D1 125		A / P

GF1081

STD

øt (mm): 150 (mm): 22

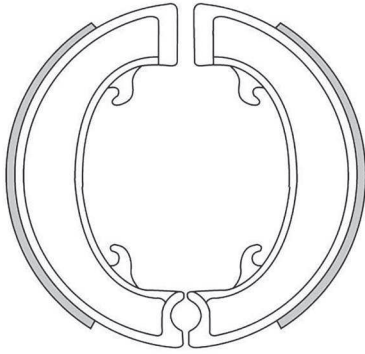

BSA	Year	A/P
C15 250		A / P

GF1084

STD

FTR

øt (mm): 150 (mm): 25

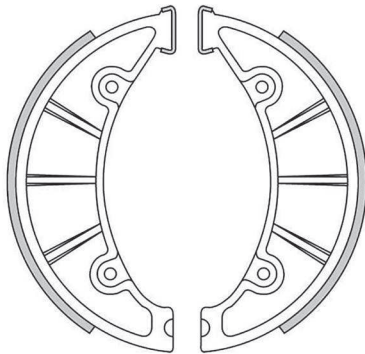

ZUNDAPP	Year	A/P
KS 50 SPORT		P
KS 50 SUPER SPORT		P
KS 100		P

GF1088

STD

øt (mm): 120 (mm): 25

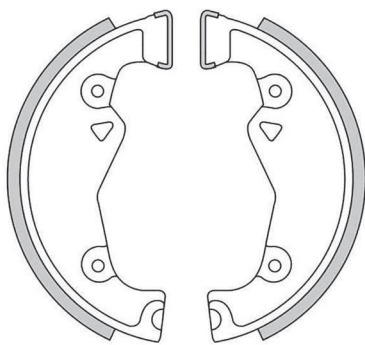

ZUNDAPP	Year	A/P
SUPER COMBINETTE 429		A / P
SUPER COMBINETTE 433		A / P
FALCONETTE 435		A / P
KS 50 500		A / P
KS 75 500		A / P

GF1090

STD

øt (mm): 180 (mm): 25

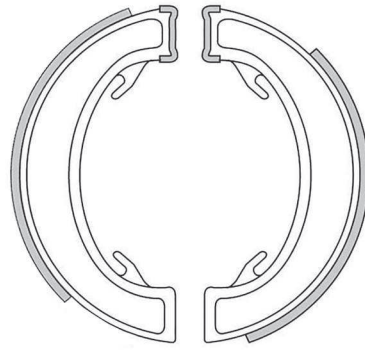

TRIUMPH	Year	A/P
BONNEVILLE 650 T 120	66->	A
T 100 750	70->	A
T 150 750	69->	A
T 140 850	70->	A

GF1092

STD

øt (mm): 200 (mm): 40

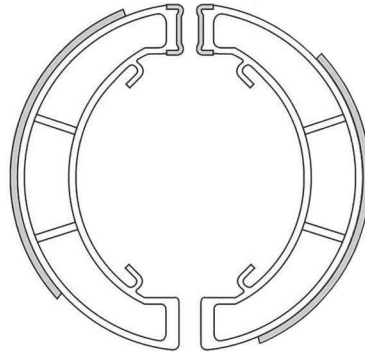

TRIUMPH	Year	A/P
BONNEVILLE 650 T 120	66->	P
T 100 750	70->	P
T 150 750	69->	P
TIGER 750 TR7V	73->75	P
TIGER TRAIL 750 TR7T	81->83	P
T 140 850	70->	P

GF1093

STD

øt (mm): 80 (mm): 18

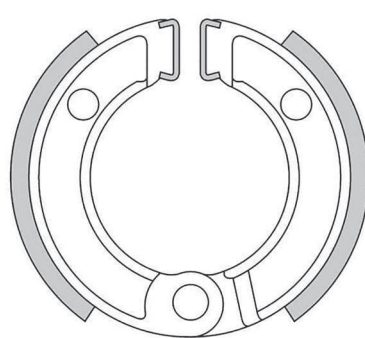

HONDA	Year	A/P
CRF 50	04->11	A / P
NB 50	85->	A
NB 50 DELUX	82->	A
NB 50 MELODY	82->	A
NB 50 MSB	82->	A
NC 50 all models	79->	A / P

...GF1093

... segue HONDA	Year	A/P
NC 50 EXPRESS 2/3	82->	A / P
ND 50	82->	A
ND 50 MELODY 2 all models	82->	A
NE 50 VISION	85->	A
NP 50 D MELODY MINI	83->	A
NX 50 A	82->	A
NX 50 B	82->	A
NX 50 MB CAREN	82->	A
OR 50	93->	A
PC 50 KI	79->	A / P
QR 50	93->	A
QR 50 ED	82->	A
SA 50 ELITE LX	88->90	A
Z 50 all models	79->91	A / P
PEUGEOT	Year	A/P
ST 50		A
STL 2 50		A
SUZUKI	Year	A/P
DR Z 70	08->20	A / P
YAMAHA	Year	A/P
TT 50 EV/EW	06->12	A / P
TT R 50	06->20	A / P

GF1098

STD

øt (mm): 125 (mm): 25

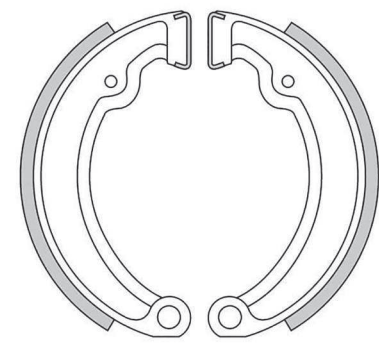

MZ	Year	A/P
SIMSON 50		A / P
SIMSON 80		A / P
SIMSON	Year	A/P
SCWALBE 50		A / P
SR 50 /1 GAMMA	94->	P
SR 50 CC/CCE/XG/XGE		A / P
SR 50 GAMMA E	94->	P
SR 50 XC/XCE		P
SR 80 /1 GAMMA	94->	P
SR 80 CC/CCE		A / P
SR 80 XCE		P

GF1105

STD

FTR

øt (mm): 130 (mm): 28

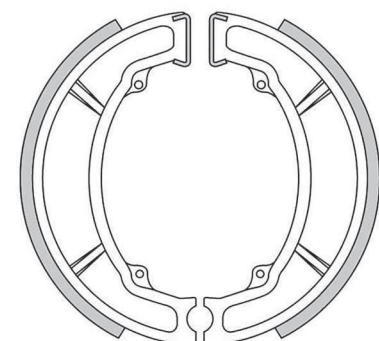

APRILIA	Year	A/P
SCARABEO 100 (motore Minarelli)	00	P

FIGURATO GANASCE CON APPLICAZIONI | BRAKE SHOES DRAWINGS AND APPLICATIONS | DESSINS MÂCHOIRES DE FREIN AVEC APPLICATIONS |
DISEÑOS MORDAZAS CON RELACIÓN | ZEICHNUNGEN VON BREMSBACKEN MIT VERWENDUNGSLISTE



...GF1105

MBK	Year	A/P
YN R 100 OVETTO	00->	P
YQ 100 NITRO	00->02	P
YAMAHA	Year	A/P
DT 80 LC1 (37A)	81->84	P
DT 80 LC2 (53A)	85->92	P
RD 80 LC1	82	P
TZR 80	->91	P
YFM 80	85->88	P
DT 100	76->80	P
YFM 100 CHAMP	87->91	P
YZ 100	78->83	P
125 ACTIVE	90->	A / P
BELUGA 125 BL	85->87	A
BELUGA 125 BL	85->92	P
BELUGA 125 XC	93->	P
CYGNUS F 125 XC	00->	P
DT 125	74->77	A / P
DT 125 (Italia)	86->87	P
DT 125 CHESTERFIELD SCOUT	88->	P
DT 125 E	78->79	A / P
DT 125 LC	82->85	A
DT 125 LC	82->87	P
DT 125 LC TENERE	88->	P
DT 125 MX	80->81	A / P
DT 125 TENERE (Italia)	87->	P
IT 125 G - H - J	80->82	P
RD 125 DX	75->76	P
RD 125 LC	82->87	P
RS 125	75	P
RS 125 DX	76->80	P
RZ 125 (1GV 030101-)	85	P
SR 125	82->91	A
TY 125	80->82	P
TZR 125	87->89	P
TZR 125 (versione Spagna)	87->	P
XT 125	76->81	P
XT 125	82->83	A
XV 125 VIRAGO	97->01	P
YBA 125 ENTICER	05->06	P
YFA 1 125 BREEZE	89->91	P
YZ 125	76->82	P
CRYPTON 135 X	06->13	P
RX 135	81	P
DT 175	74->96	A / P
IT 175	80->82	P
TY 175	77->80	P
CYGNUS 180 XC	83->85	A
RT 180	90->92	P
DT 200 R	87	P
TW 200	87->00	A
XV 240 VIRAGO	91->92	P
SR 250	87->90	P
SR 250 E (España)	90->	P
SR 250 SE	80->82	P
SR 250 US CUSTOM	80->81	P
TTS 250	87->92	P
TY 250	77->80	P
XL 250 G	80->	P
XT 250	80->	A / P
XV 250 VIRAGO	89->94	P
YZ 250	80->87	P
TT 350	85->89	P
XT 350	85->90	P
YZ 490	83->84	P
TT 600	89->92	P
TT 600 L	83->84	P
TT 600 N	85->88	P

GF1107
STD

øt (mm): 200 (mm): 35

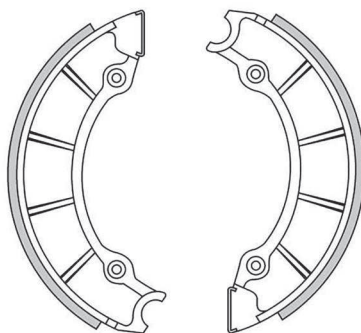
KAWASAKI

	Year	A/P
H1 500 Mach 111	69->72	A
H1 500 S Mach 111	71	A

GF1108
STD

øt (mm): 180 (mm): 35

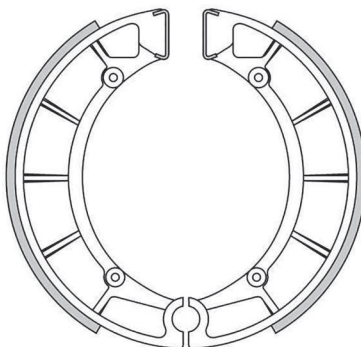
KAWASAKI

	Year	A/P
H1 500 Mach 111	69->72	P
H1 500 S Mach 111	71	P

GF1109
STD

øt (mm): 180 (mm): 38

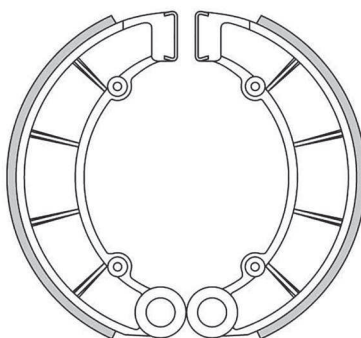
HONDA

	Year	A/P
CB 650 A - Z	79->81	P
CB 750	69->79	P
CB 750	80	P

GF1110
STD

øt (mm): 162 (mm): 25

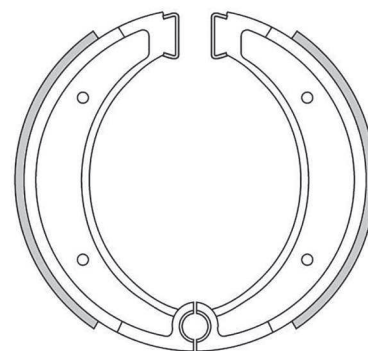
HUSQVARNA

	Year	A/P
CR 125	81->82	A
CR 125	81->84	P
RC 125	81->82	A / P
WR 125	->85	P
WRE 125	->87	P
CR 240	->80	A
CR 240	->86	P
RC 240	->80	A
RC 240	->82	P
WR 240	83->84	P
WRE 240	83->	P
CR 250	->80	A
CR 250	->84	P
RC 250	->80	A
RC 250	->82	P
WR 250	83->86	P
WRE 250	83->	P
CR 390	->80	A / P
RC 390	->80	A / P
CR 430	81->82	P
OR 430	81->82	P
RC 430	81->82	P
WR 430	81->82	P
WRE 430	81->82	P
XC 430	81->82	P
CR 490	83->	P
AE 500	84->	P
TC 500	84->	P
TE 510	84->87	P
TX 510	84->	P

GF1112
STD

øt (mm): 180 (mm): 28

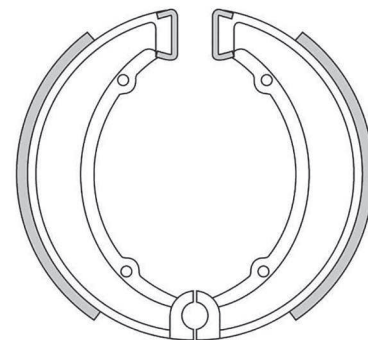

BSA

	Year	A/P
A7 - A 10 125		P

GF1120

STD | FTR

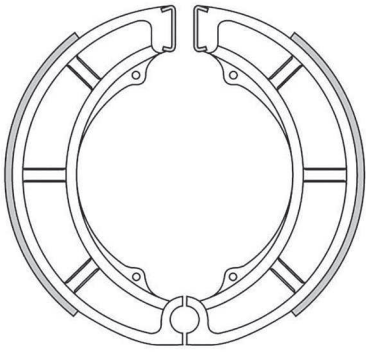
øt (mm): 180 (mm): 40



SUZUKI	Year	A/P
LT 250 EFF/EFG	85->86	P
LT-F 250 4WD QUADRUNNER	97->98	P
LT-F 300	88->89	P
LT-F 300 F KING QUAD	99->01	P
LT-F 300 QUADRUNNER 4WD	91->98	P
LT-A 500 F QUADRUNNER	00->01	P
LT-F 500 F QUADRUNNER	98->00	P
RE 500	75->76	P
GV 700 GL	85->	P
GT 750	72->77	P

GF1121

STD

øt (mm): 180 (mm): 28

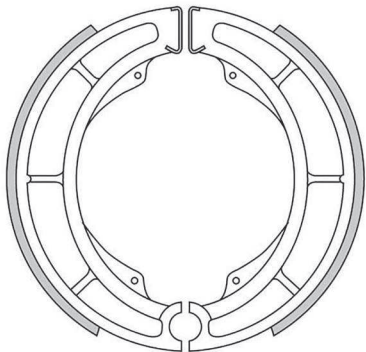

SUZUKI	Year	A/P
GT 250 K - L - M	73->78	P
T 250	70->72	P
T 250 SUPER SIX	66->68	P
T 350 all models	69->72	P
GT 380 A - B - K	73->77	P
GT 380 J	72	P
GS 400	77->78	P
GT 500	76->77	P
T 500 all models	68->75	P
GT 550 J	72->	P
GT 550 K - L - M	73->75	P

GF1124

STD

øt (mm): 130 (mm): 30

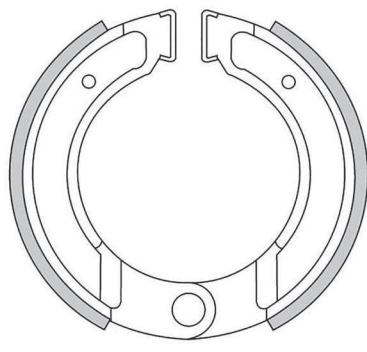

HONDA	Year	A/P
CR 480 R	82	P

KTM	Year	A/P
HOBBIY-DUO-PRO 50 COMET 40PI-KJ		A / P
125 CROSS	80->83	A / P
GS 125	74->82	A / P
GS 125 LC	83	P
MX 125	74->82	A / P
GS 175	72->78	A / P
MC 250	74->83	A / P
MX 250	74->81	A / P

GF1125

STD

øt (mm): 120 (mm): 20

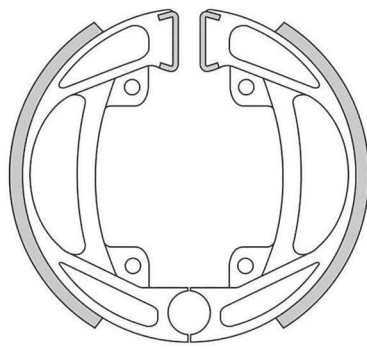

HUSQVARNA	Year	A/P
CR 125	->80	A / P
RC 125	->80	A / P

KREIDLER	Year	A/P
125	->80	P
MUSTANG 125	83->	P
RS 125	80->	P

GF1126

STD

øt (mm): 181 (mm): 25

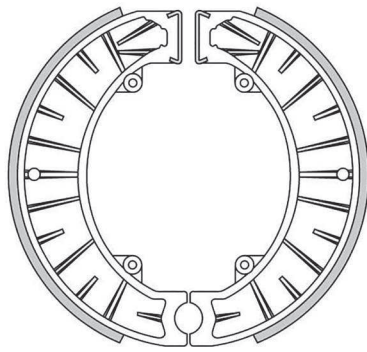

KTM	Year	A/P
GS 175	79->	P
MX 250	82	A / P

...GF1126

... segue KTM	Year	A/P
GS 350	83->	P
GS 390	80->	P
MX 495	82->83	P
GS 500	83	P
MX 500	->82	P

GF1130

STD

øt (mm): 180 (mm): 30

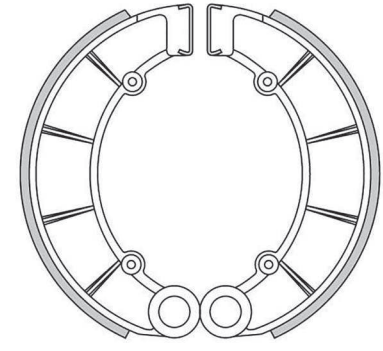

HONDA	Year	A/P
CB 550	78->80	P

GF1131

STD

øt (mm): 160 (mm): 35

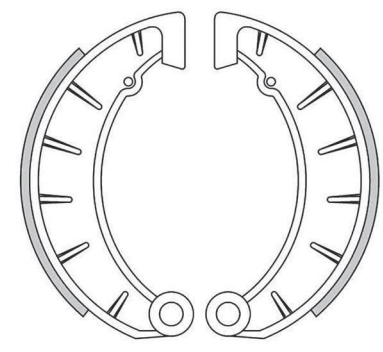

CZ - JAWA	Year	A/P
CHOPPER 125	03->04	P
JAWA 125	->74	A / P
TRAVEL 125	03->04	P
JAWA 175	->74	A / P
JAWA 250	->74	A / P
CALIFORNIAN 350	03->04	P
CHOPPER 350	03->04	P
JAWA 350	->74	A / P
TRAMP 350	03->04	P

FIGURATO GANASCE CON APPLICAZIONI | BRAKE SHOES DRAWINGS AND APPLICATIONS | DESSINS MÂCHOIRES DE FREIN AVEC APPLICATIONS |
DISEÑOS MORDAZAS CON RELACIÓN | ZEICHNUNGEN VON BREMSBACKEN MIT VERWENDUNGSLISTE



GF1132
STD

øt (mm): 180 (mm): 25

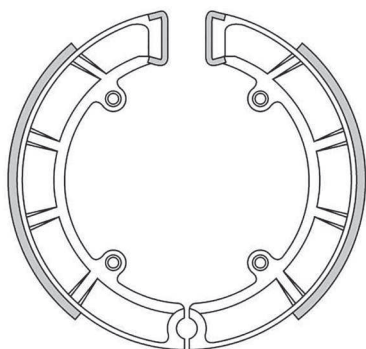
CZ - JAWA

Year	A/P
SCRAMBLER CROSS 125	A/P
JAWA 250 CROSS	A/P
SCRAMBLER CROSS 250	A/P
SCRAMBLER CROSS 350	A/P
SCRAMBLER CROSS 380	A/P
JAWA 400 CROSS	A/P

GF1133
STD

øt (mm): 160 (mm): 35

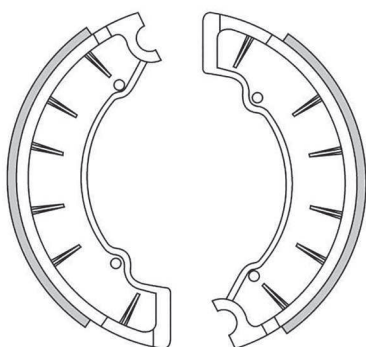
CZ - JAWA

Year	A/P
JAWA 125	75-> A
JAWA 175	75-> A
JAWA 250	75-> A
JAWA 350	75-> A

GF1135
STD | FTR

øt (mm): 140 (mm): 30

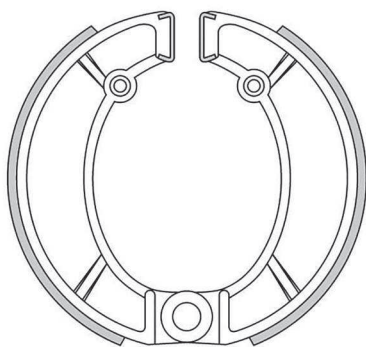
BULTACO

Year	A/P
PURSANG 125 MK7/8	74->75 P
SHERPA S 125	61->72 P
SHERPA 150	P
SHERPA 151	P
FRONTERA 250 GM	77->79 A/P
FRONTERA 250 MK10	77->78 A/P

...GF1135

Year	A/P
... segue BULTACO	
FRONTERA 250 MK11/12	79->81 A/P
FRONTERA 250 MK9	75->76 A/P
PURSANG 250 MK11/12	78-> P
PURSANG 250 MK2/3/4	67->71 P
PURSANG 250 MK5	72 P
PURSANG 250 MK7/8/10	75->77 P
FRONTERA 360 MK9	75->76 A/P
MONTJUIC 360	80-> P
PURSANG 360 MK7/8	74->75 A/P
FRONTERA 370 GM	77->79 A/P
FRONTERA 370 MK10	77->78 A/P
FRONTERA 370 MK11/12	79->81 A/P
PURSANG 370 MK9/10	76->77 A/P
MONTESA	
Year	A/P
RC 248	A/P

GF1136
STD

øt (mm): 160 (mm): 25

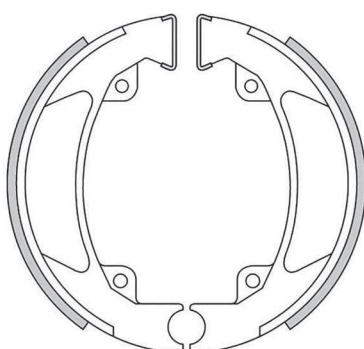
KREIDLER

Year	A/P
FLORETT 80 E	P
FLORETT 80 L	P
125	->80 A

GF1137
STD | FTR

øt (mm): 125 (mm): 25

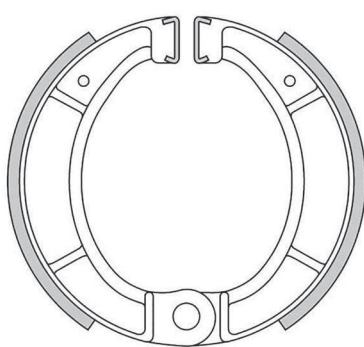
BULTACO

Year	A/P
SHERPA S 100	61->72 A/P
SHERPA 124	A/P
LOBITO 125 MK3	69->72 A/P
LOBITO 125 MK4/5/7/8	71->75 A/P
LOBITO 125 MK6	73 A/P
PURSANG 125 MK5	72 A/P
PURSANG 125 MK6	73 A
PURSANG 125 MK7/8	74->75 A
PURSANG 125 MK9/10	76->77 A/P
SHERPA S 125	61->72 A
SHERPA 150	A
SHERPA 151	A
SHERPA N 155	60->65 A
SHERPA S 175	61->72 A
PURSANG 176 MK6	A

...GF1137

Year	A/P
... segue BULTACO	
PURSANG 200 METISE	A
PURSANG 200 MK8/9/10	74->77 A/P
SHERPA N 200	A
SHERPA S 200	61->72 A
LOBITO 250	A/P
PURSANG 250 MK11/12	78-> A
PURSANG 250 MK2/3/4	67->71 A
PURSANG 250 MK5	72 A
PURSANG 250 MK6	73 A
PURSANG 250 MK7/8/10	75->77 A
SHERPA 250 T MO	71->81 A/P
SHERPAT 250 (MOD 49)	68->71 A
PURSANG 350 MK11/12	78-> A
PURSANG 350 MK5	72 A
PURSANG 350 MK6	73 A
SHERPA 350 I - A - N	A/P
SHERPA 350 T MO	71->81 A
MONTJUIC 360	80-> A

GF1138
STD | FTR

øt (mm): 140 (mm): 40

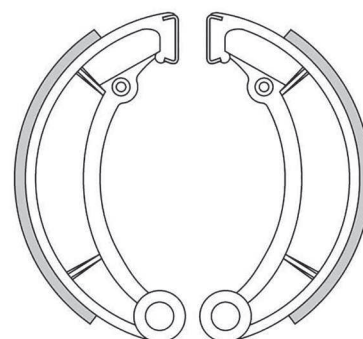
BULTACO

Year	A/P
PURSANG 125 MK6	73 P
SHERPA N 155	60->65 P
SHERPA S 175	61->72 P
PURSANG 176 MK6	P
PURSANG 200 METISE	P
SHERPA N 200	P
SHERPA S 200	61->72 P
PURSANG 250 MK6	73 P
SHERPAT 250 (MOD 49)	68->71 P
PURSANG 350 MK11/12	78-> P
PURSANG 350 MK5	72 P
PURSANG 350 MK6	73 P
SHERPA 350 T MO	71->81 P

GF1140
STD

øt (mm): 180 (mm): 30

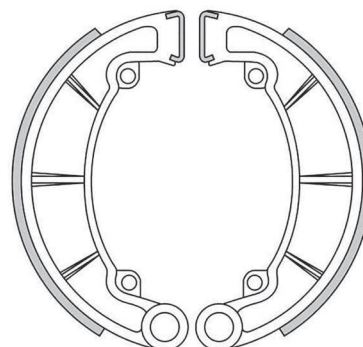

KAWASAKI

Year	A/P
KH 250	77->80 P
S1 250 B	75-> P
KH 400 A3-5	76->78 P

GF1141

STD

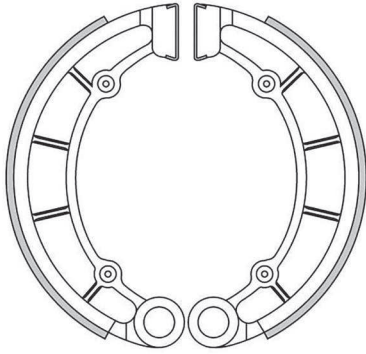
øt (mm): 180 (mm): 35



KAWASAKI	Year	A/P
KLF 300 BAYOU (C1/C12)	89->05	P
KVF 300 PRAIRIE 2x4	99->01	P
KVF 300 PRAIRIE 4x4	99->01	P
KLF 400 BAYOU 4x4	93->98	P
KVF 400 PRAIRIE 2x4 D1/D3	99->01	P
KVF 400 PRAIRIE 4x4 C1/C3	99->01	P
KVF 400 PRAIRIE A1/A2 - B1	97->98	P
H1 500	73->75	P
KH 500	74->75	P

GF1142

STD

øt (mm): 200 (mm): 35

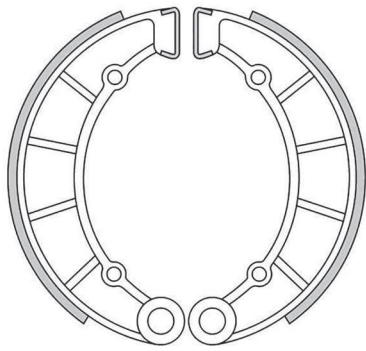

KAWASAKI	Year	A/P
Z 900 A4	77	P
Z 900 Z1A - Z1B	74->76	P

GF1143

STD

øt (mm): 80 (mm): 18

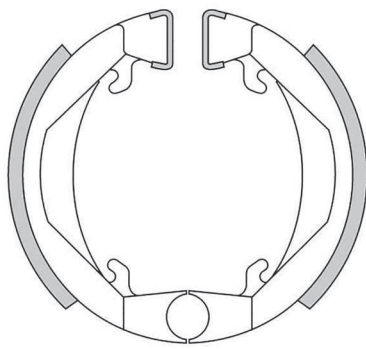

HONDA	Year	A/P
CAMINO 50 all models	80->	A / P
PA 50 all models	80->	A / P
PF 50 M	75->	A / P
PX 50 all models	82->83	A
PX 50 E	84->	A

...GF1143

KTM	Year	A/P
SX 50 ADVENTURE	98->	A / P
SX 50 JUNIOR LC	02->04	P
SX 50 PRO JUNIOR LC	02->	P
SX 50 PRO SENJOR LC	02->03	P
SX 50 SENJOR ADVENTURE	04->	P

MOTOBECANE	Year	A/P
all models 50 (mozzi atom)	88->89	A
all models 50 (mozzi leleu)	88->89	A

PEUGEOT	Year	A/P
103/104/105 50	76->	A / P
ASV 50 (Forcella telescopica)	93->	A / P

PUCH	Year	A/P
MAXI 30 all models		A / P
MAXI 40 all models		A / P
GTL 50		P
MONZA 50 4 GP all models		A / P
MONZA 50 4 SL		A / P
80 /6		P

GF1144

STD

øt (mm): 105 (mm): 25

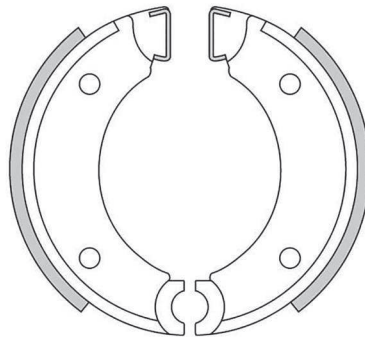

PUCH	Year	A/P
K2 50		A / P
K25 50		A / P
K3T 50		A / P
KA 50		A / P
MS 50 P		A / P

GF1145

STD

øt (mm): 160 (mm): 30

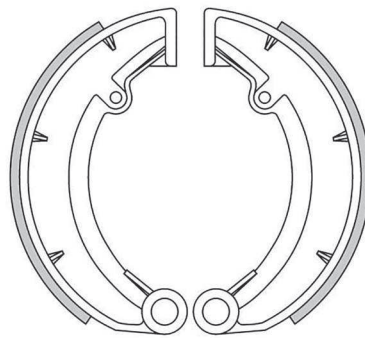

MZ	Year	A/P
TS 125		A
TS 150		A
ETZ 250		A
ETZ 250	->00	P
TS 250		A / P

GF1146

STD

øt (mm): 110 (mm): 30

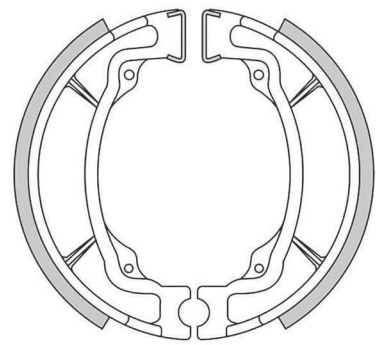

HYOSUNG	Year	A/P
FX 110	02->	P
KR 110 MASTER	04->	P
MIDAS 110 PLUS	98->	P

KAWASAKI	Year	A/P
AE 50	81->84	A / P
AR 50	81->97	P
KMX 50	88->	P
AE 80	81->83	A / P
AR 80	81->91	P
KC 100	80->83	A / P
KE 100	79->98	A / P
KG 100	83->	P
KH 100	78->83	P
KM 100	78->81	P
KLF 110 MOJAVE	87->88	A
KLT 110 A1/A3	84->86	A
KLX 110	02->20	P
KAZE 115 R	98->	P
KLT 160	85	A
KLT 185 A1/A2	86->87	A
KLT 200	81->84	A
KLT 200	83->84	A
KLT 250 all models	83->85	A

MODENAS	Year	A/P
KRISS 115	->98	A / P

SUZUKI	Year	A/P
AP 50	71->80	A / P
F 50	71->	A / P
FR 50	74->81	A / P
GT 50	77->80	P
RM 50	78->80	A / P
TS 50	79	P
TS 50	79->83	A
ZR 50 KEN - KEX	79->83	P
FR 70	74->76	A / P
3 E 80		P
FR 80 all models	76->83	A / P
GT 80 L	81->	P
RM 80	77->79	A / P
TS 90	71->	A
A 100 all models	74->80	A / P
GP 100	78->87	P
GP 100 N/UN	79->92	P
RM 100	76->81	A
TS 100	73->75	A
DR Z 110	03->05	P
SMASH 110	03	A / P
CS 125 D	83->	A / P
FX 125		P
RV 125	73	A
RV 125 VAN VAN	02->12	P
TS 125	72	A
TS 185	73	A
RV 200 K2/K3	02->03	P
PE 250 N	79	A / P
PE 250 X - Z	81->82	A
RL 250	74->82	A
RL 325	78->82	A

FIGURATO GANASCE CON APPLICAZIONI | BRAKE SHOES DRAWINGS AND APPLICATIONS | DESSINS MÂCHOIRES DE FREIN AVEC APPLICATIONS |
DISEÑOS MORDAZAS CON RELACIÓN | ZEICHNUNGEN VON BREMSBACKEN MIT VERWENDUNGSLISTE



GF1147
STD

øt (mm): 130 (mm): 28

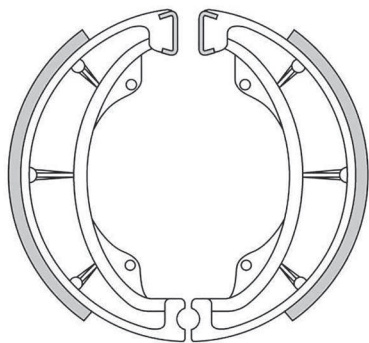

HYOSUNG	Year	A/P
GV 250	02->	P

KAWASAKI	Year	A/P
KH 100	78->81	A
KH 100	84->87	P
KM 100	78->81	A
KLF 110 MOJAVE	87->88	P
KLT 110 A1/A3	84->86	P
AR 125	82->94	P
BN 125 ELIMINATOR	00->07	P
KE 125	76->85	P
KH 125	82->98	P
KX 125	74->80	P
KLT 160	85	P
KDX 175	80->82	P
KLT 185 A1/A2	86->87	P
Z 200	77->82	P
KDX 250	81->84	P
KLX 250 A1 - A2	79->80	P
KX 250	74	A
KX 250	82->85	P
Z 250 C1 - C2	81->	P
KX 500	83->86	P
KLR 570	84->91	P
KLR 600	84->86	P
KLR 600 ELECTRIC STARTER	85->94	P

SUZUKI	Year	A/P
RG 80 GAMMA	->93	P
RM 80 HD - HF	83->85	A
FB 90	01	A / P
TS 90	71->	P
GP 100 N/UN	79->92	A
RM 100	76->78	P
TS 100	73->81	P
TS 100	76->87	A
DF 125		P
DR 125 S	82->94	A
DR 125 S	82->01	P
EN 125	05->09	P
ER 125		A / P
GN 125	82->01	P
GN 125 HS	00->11	P
GP 125	78->84	P
GS 125	82->84	A
GS 125	82->00	P
GT 125	74->79	P
GZ 125 MARAUDER	98->11	P
RG 125 E	82->84	P
RG 125 W GAMMA	86->90	P
RM 125	76->78	P
RM 125	76->83	A
RV 125	73->76	P
RV 125	74->76	A
T 125 STINGER	69->71	A / P
TF 125 FARM BIKE	78->05	A / P
TS 125	72->83	P
TS 125	73->87	A

...GF1147

... segue SUZUKI	Year	A/P
TS 125 ERN (From F No 302346)	79	A / P
TS 125 ERN (Up to F No 302345)	79	A / P
TS 125 ERZ - FFS	82	A
TS 125 N from Frame No.178872	84	A / P
TS 125 N to Frame No.178871	84	A / P
VL 125 INTRUDER	00->08	P
X4 125		P
PE 175	78->79	P
PE 175	78->81	A
GT 185	74->79	P
TS 185	73->81	P
TS 185	74->81	A
DF 200 EV/EW/EY (SH42A)	98->00	P
DR 200	86->13	P
DR 200 DJEBEL	93->13	P
DR 200 S	15->17	P
GT 200	79->82	P
SB 200	79->80	P
DR 250	81->82	A / P
DR 250 S	83->89	P
GN 250	85->97	P
GZ 250 MARAUDER	99->08	P
RL 250	74->82	P
RM 250	76->78	A
TU 250 GRASS TRACKER - BIG BOY	00->01	P
TU 250 S VOLT	92->97	P
TU 250 X VOLT	97->00	P
VL 250 INTRUDER	00->07	P
RL 325	78->82	P
RM 400	78	A
DR 500 SD - SE	81->83	A
RM 500	83->86	P
DR 600 R DAKAR-DJEBEL	87->88	P
DR 600 S	86->88	P
SP 600	85->	P

GF1148
STD

øt (mm): 120 (mm): 28

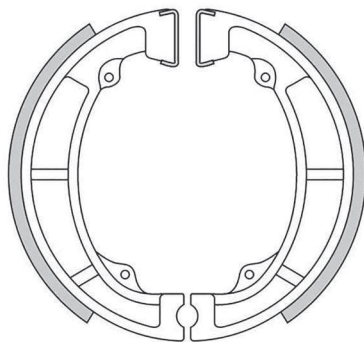

KAWASAKI	Year	A/P
KE 125	76->85	A
KX 125	74->80	A
KDX 175	80->82	A
KE 175	76->83	A / P
KL 250	80->84	A
KLX 250 A1 - A2	79->80	A

GF1150
STD

øt (mm): 160 (mm): 30

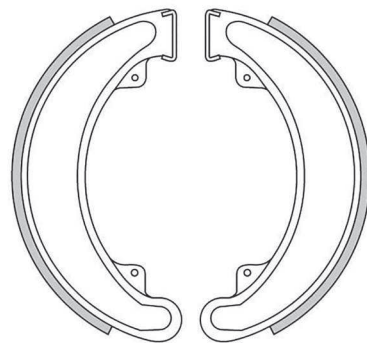

HONDA	Year	A/P
ATC 250 ESF/ESG/ESH/ESJ	85->88	P
CB 250	73->75	P
CB 250 G5	75->	P
CJ 250 I	77->	P
TRX 250 FOURTRAX	85->87	P
TRX 300 FOURTRAX (2WD)	88->00	P
TRX 300 FW FOURTRAX (4WD)	88->00	P
CB 350 K4		P
CB 360 G5 all models	75->	P
CJ 360 T all models	78->	P
CB 400 F - F1 - F2	75->79	P

GF1151
STD

øt (mm): 90 (mm): 18

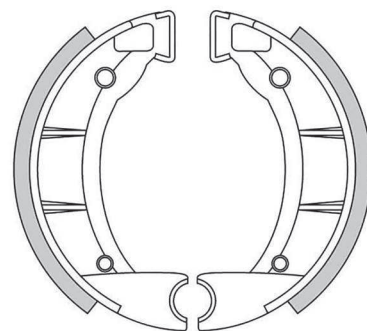

BENELLI	Year	A/P
CITYBIKE 50		A / P
S 50	81->87	A
S 50 (tutti i modelli)	87->	A
S 50 LUSSO	81->87	A
SCOOTY 50		A / P

FANTIC	Year	A/P
ISSIMO 50	84->	A / P
ISSIMO 50 (ruote lega)		A / P

GARELLI	Year	A/P
BASIC 50 (ruota lega fondermonte)		A / P
NOI 50 (ruota lega fondermonte)		A / P
VIP 50 ruota lega (fondermonte)		A / P

PUCH	Year	A/P
MAXI 80 EXECUTIVE	88->	P

GF1152

STD | FTR

øt (mm): 160 (mm): 30

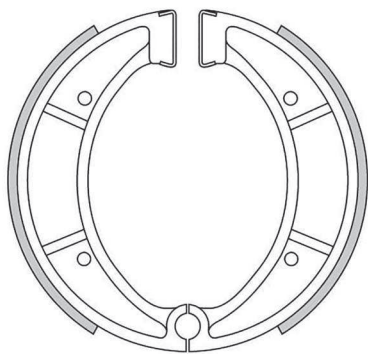

HUSQVARNA	Year	A/P
CR 125	83->84	A
CR 125	85->90	P
RC 125	83->	A
WR 125	->82	A
WR 125	86->90	P
WRE 125	->82	A
WRE 125	88	P
CR 240	81->82	A
CR 240	87->	P
RC 240	81->82	A
WR 240	85->90	P
WRK 240	88->	P
CR 250	81->82	A
CR 250	85->95	P
RC 250	81->82	A
WR 250	87->89	P
XC 250	87->	P
WRK 260	88->	P
WR 400	85->	P
AE 430	88->	P
AUTO 430	87->	P
CR 430	81->82	A
CR 430	87->	P
OR 430	81->82	A
RC 430	81->82	A
WR 430	81->82	A
WR 430 AE	87->	P
WRE 430	81->82	A
XC 430	81->82	A
XC 430	87->	P
CR 500	85->	P
XC 500	87->	P
510	86->	P
TC 510	88->92	P
TE - AC - LC 510	87->	P

GF1153

STD | FTR

øt (mm): 122 (mm): 30

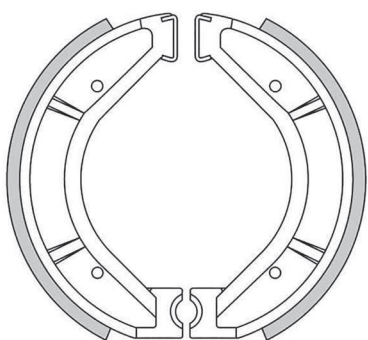

OSSA	Year	A/P
CROSS 125	74->	A
CROSS 250	74->	A

...GF1153

... segue OSSA	Year	A/P
FUEGO 250	74->	A
TRIAL 250 (all models)	->80	A / P
TRIAL 350 (all models)	->80	A / P

GF1154

STD | FTR

øt (mm): 110 (mm): 30

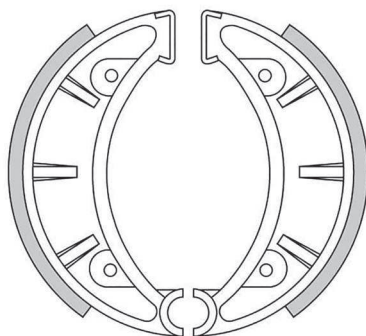

MONTESA	Year	A/P
MKS 50	87->	P
COTA 123	->82	A / P
MH 123	83->	P
MH 200	83->	P
COTA 242	83->	P
COTA 290	->83	A / P
COTA 304	87	P
TRIAL 330	85->	P
T 348	->83	A / P
COTA 349	82->83	A / P
MH 349	83->	P

PUCH	Year	A/P
CONDOR 50		P
MONZA 50	83	A / P
COBRA 75	85->	P
COBRA 80	84->	P

GF1155

STD

øt (mm): 110 (mm): 25

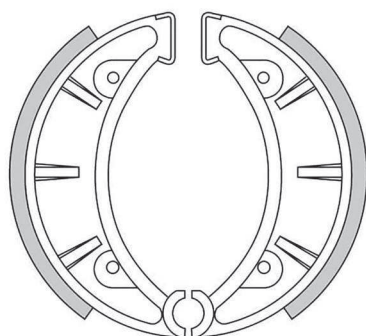

CAGIVA	Year	A/P
DG 350 TRIAL	83->	A / P

OSSA	Year	A/P
TRIAL 250 (all models)	81->	A
TRIAL 350 (all models)	81->	A

PUCH	Year	A/P
BORRASCA 50		A / P
MINICROSS 50		A / P

GF1156

STD

øt (mm): 120 (mm): 25

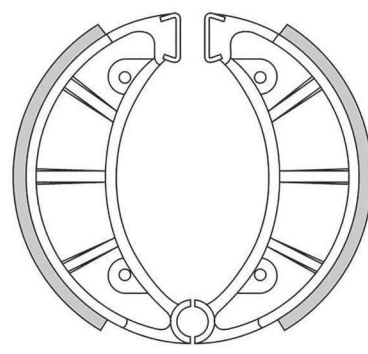

FB MINARELLI	Year	A/P
MR 80		P

OSSA	Year	A/P
TRIAL 250 (all models)	81->	P
TRIAL 350 (all models)	81->	P

PUCH	Year	A/P
MONZA 50	84->	P
MONZA 50 (ruote in lega 160x17)	84->	A / P

RIEJU	Year	A/P
MR 80	95->	P

GF1158

STD

øt (mm): 130 (mm): 22

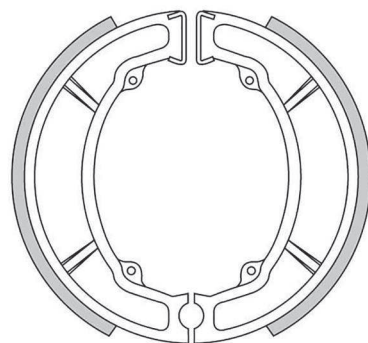

SUZUKI	Year	A/P
LT 80 all models	87->01	P
LT-Z 90	07->20	P
LT 125	85->87	P
PE 175	82	A
RM 250	80	A
RM 250	84->86	P
RM 400	80	A
RM 465	81->82	P

GF1159

STD

øt (mm): 140 (mm): 25

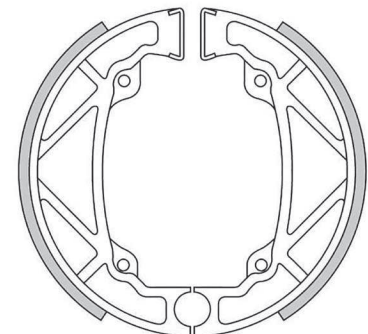

KTM	Year	A/P
MX 125	83	A
MX 250	83	A

FIGURATO GANASCE CON APPLICAZIONI | BRAKE SHOES DRAWINGS AND APPLICATIONS | DESSINS MÂCHOIRES DE FREIN AVEC APPLICATIONS | DISEÑOS MORDAZAS CON RELACIÓN | ZEICHNUNGEN VON BREMSBACKEN MIT VERWENDUNGSLISTE



...GF1159		
... segue KTM	Year	A/P
MX 500	->82	A

GF1160	STD
øt (mm): 160 (mm): 25	

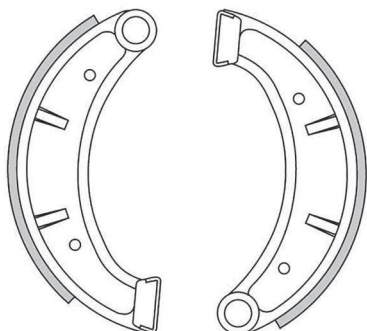

HUSQVARNA	Year	A/P
WR 125	83->85	A
WRE 125	83->87	A
CR 240	83->86	A
RC 240	83->	A
WR 240	83->84	A
WRE 240	83->	A
CR 250	83->84	A
RC 250	83->	A
WR 250	83->86	A
WRE 250	83->	A
WR 400	85	A
CR 490	83->	A
AE 500	84->	A
TC 500	84->	A
TE 510	84->87	A
TX 510	84->	A

GF1161	STD
øt (mm): 120 (mm): 22	

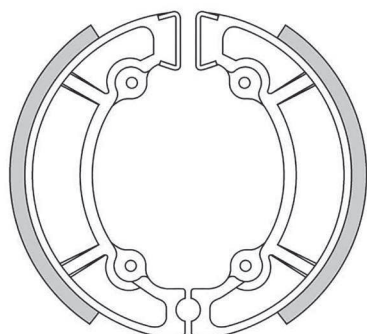

SUZUKI	Year	A/P
RM 125	81->86	P
RM 250	81->82	P

GF1162	STD
øt (mm): 130 (mm): 22	

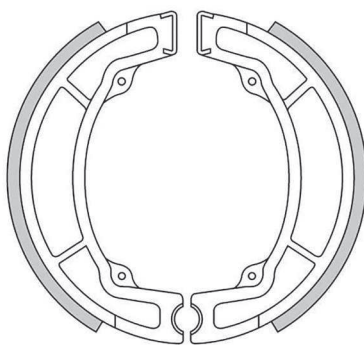

YAMAHA	Year	A/P
XT 125	76->81	A
YZ 125	76->82	A
IT 175	80->82	A
IT 250 G	80	A
IT 250 H - J - K	81->83	A
TY 250	81->83	A
XL 250 G	80->	A
YZ 250	77->79	A
YZ 400	77->79	A
IT 425 G	80->00	A
IT 500 G - H	80->81	A
TT 500	80->81	A

GF1163	STD
øt (mm): 130 (mm): 22	

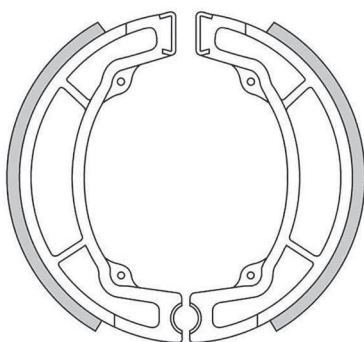

YAMAHA	Year	A/P
YZ 125	83->86	P
IT 200	84	A/P
TY 250 S - RS	84->90	A

GF1164	STD
øt (mm): 130 (mm): 22	

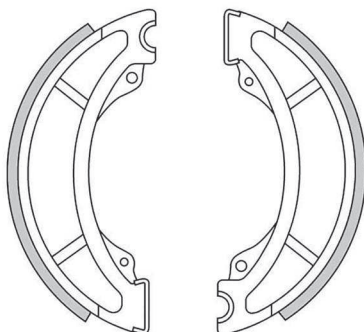

YAMAHA	Year	A/P
YZ 125	84	A

...GF1164		
... segue YAMAHA	Year	A/P
IT 250 L	84->	A
YZ 250	81->84	A
IT 465	81->82	A
YZ 465	80	A
IT 490	84	A
YZ 490	81->84	A
TT 600 L	83->84	A

GF1165	STD
øt (mm): 130 (mm): 22	

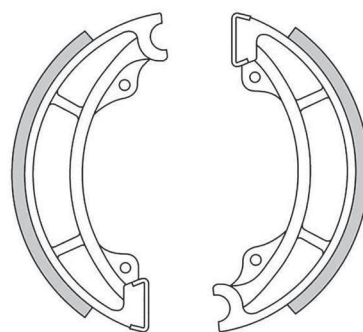

ATK (USA)	Year	A/P
ATK 560	84->85	P

SUZUKI	Year	A/P
RM 125	84	A
RM 250	83	A
RM 500	83->84	A

GF1166	STD
øt (mm): 150 (mm): 22	

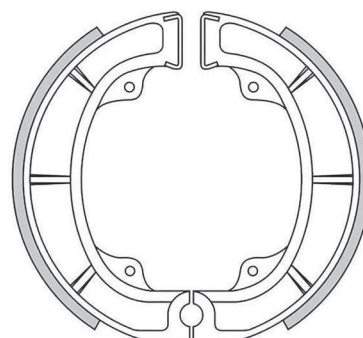

SUZUKI	Year	A/P
ALT 125	83	P
LT 125	83	P
RM 250	81->82	A
RM 465	81->82	A

GF1167

STD

øt (mm): 150 (mm): 25

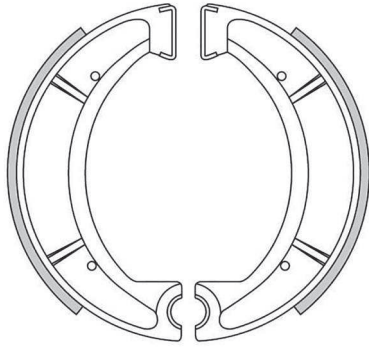

YAMAHA	Year	A/P
RD 125 DX	78->81	P
RS 125	75	A
CYGNUS 180 XC	83->85	P
RD 200 DX	75->81	P
RS 200	79->80	A/P
RS 200 C	75->80	P
DT 250	75->76	P
DT 250 MX	77->80	P
IT 250 H - J - K	81->83	P
IT 250 L	84->	P
SRX 250		P
TY 250	81->83	P
DT 400	75->77	P
DT 400 MX	75->79	P
SR 400	88->16	P
IT 465	81->82	P
YZ 465	81	P
IT 490	84	P
YZ 490	81->88	P
SR 500	78->98	P
XT 500	76->89	P
XT 500 (Austria)	83->	P
XT 550	82->83	A/P
XT 600 4 VALVES	84->86	P
XT Z 600 TENERE	83->87	P

GF1168

STD

øt (mm): 160 (mm): 25

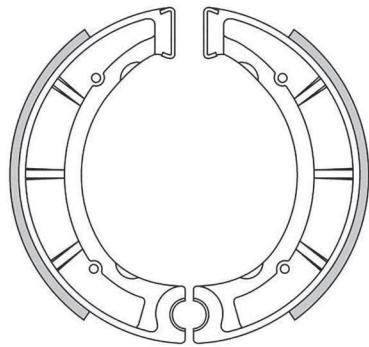

YAMAHA	Year	A/P
DT 250	75->76	A
DT 250 MX	77->80	A
IT 250 G	80	P
SR 250 SE	80->82	A
YD 250 S	91->	P
YZ 250	77->79	P
IT 425 G	80->00	P
IT 500 G - H	80->81	P
TT 500	80->81	P
XT 500	76->81	A

GF1169

STD

øt (mm): 160 (mm): 25

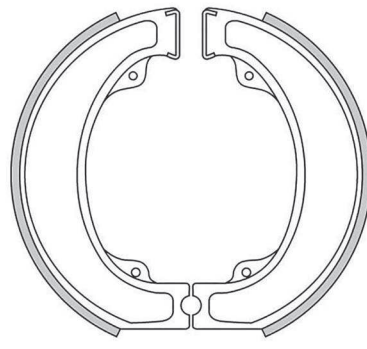

HONDA	Year	A/P
CR 250 R	78->80	P
XL 500 SA - SB	81	A

GF1170

STD

øt (mm): 140 (mm): 30

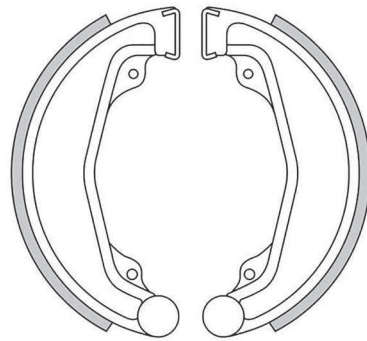

HONDA	Year	A/P
CB 175 all models	74->76	P
CB 200 B - T	76->78	P
CB 250 RSA - RSD - RSE	81->	P
CBR 250 R HURRICANE	86	P
CL 250 SC	81	P
MVX 250 F	88->	P
VT 250 F	82->87	P
VT 250 F INTEGRA	87->	P
VT 250 F2	82	P
VTR 250 INTERCEPTOR	88	P
VIZ 250	86->88	P
XL 500 SA - SB	81	P

GF1171

STD

øt (mm): 130 (mm): 30

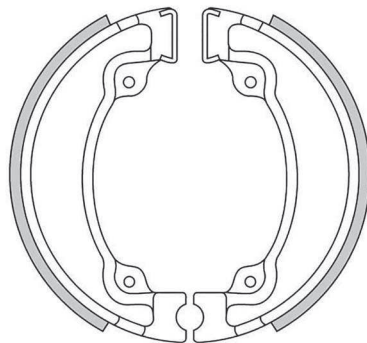

HONDA	Year	A/P
CA 125 REBEL	95->97	P
VT 125 C SHADOW	99->08	P

...GF1171

... segue HONDA	Year	A/P
XL 250 S	82	P
XL 500 R - RC	82	P
XL 500 R PARIS DAKAR	83->	P
XL 500 SZ	80	P
XR 500 R	81->82	P
XR 500 S	79->80	P
XL 600 L	85->87	P
XL 600 LD - PARIS DAKAR	83->	P
XL 600 R	83->87	P
XL 600 V TRANSALP	87->90	P

GF1172

STD

øt (mm): 130 (mm): 30

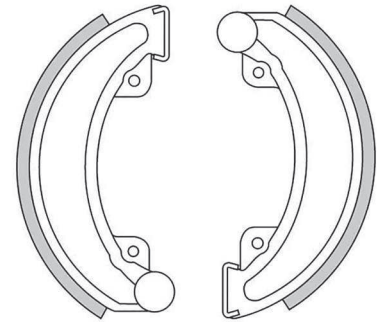

HONDA	Year	A/P
CR 250 R	->77	A
XR 250 R	81->83	A
CR 450 R	81->	A
CR 480 R	82	A
XR 500 R	81->82	A

GF1173

STD

øt (mm): 130 (mm): 22

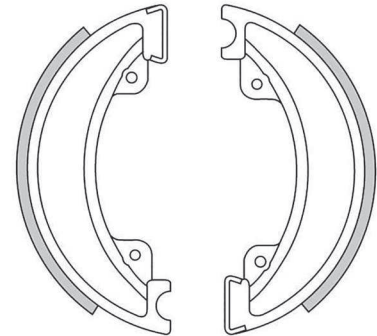

HONDA	Year	A/P
CR 125 R	82	A/P
CR 250 R	82	A
CR 480 R	83	A

FIGURATO GANASCE CON APPLICAZIONI | BRAKE SHOES DRAWINGS AND APPLICATIONS | DESSINS MÂCHOIRES DE FREIN AVEC APPLICATIONS | DISEÑOS MORDAZAS CON RELACION | ZEICHNUNGEN VON BREMSBACKEN MIT VERWENDUNGSLISTE



GF1174
STD

øt (mm): 130 (mm): 22

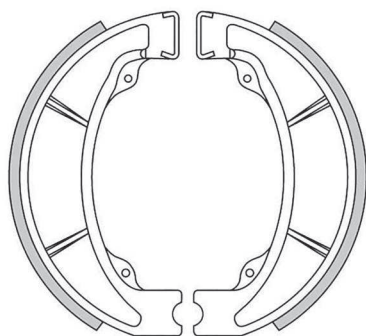

HONDA	Year	A/P
CR 125 R	83->85	P
MBX 125	84->86	P
CR 250 R	83->85	P
XL 350 R	83->84	A
CR 480 R	83	P
CR 500 R	84->85	P

GF1175
STD

øt (mm): 140 (mm): 25

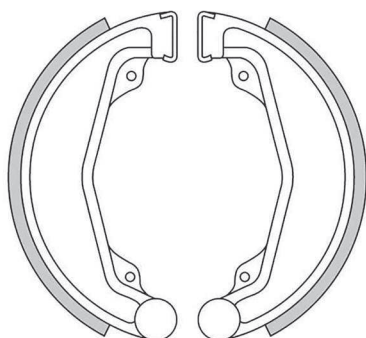

HONDA	Year	A/P
CD 125	78->	A
CM 125	82->85	A
CD 185 T	78	A
CD 200 T	79->80	A
CM 200 TA - TB	79->80	A
CL 250 SC	81	A
CM 250 C	82->	A
XL 250	78->79	P
XL 250 S	78->81	A
XR 250 S	79->80	A
XL 500 SZ	80	A

GF1176
STD
FTR

øt (mm): 125 (mm): 28

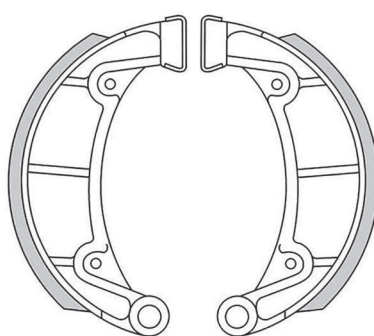

MONTESA	Year	A/P
COTA 123	83->	A
MH 123	83->	A
MH 200	83->	A
COTA 242	83->	A
TRIAL 330	85->	A
COTA 349	84->	A
MH 349	83->	A

GF1177
STD

øt (mm): 110 (mm): 30

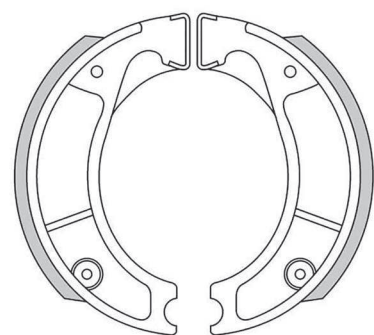

HONDA	Year	A/P
NX 250 DOMINATOR	87->93	P
XL 250	91	P
XL 250 DEGREE	91->	P
XL 250 R	81->83	P
XL 250 S	78->81	P
XLX 250	84->	P
XR 250 R	81->89	P
XR 250 S	79->80	P
XL 350 R	85->	P

GF1178
STD
FTR

øt (mm): 110 (mm): 25

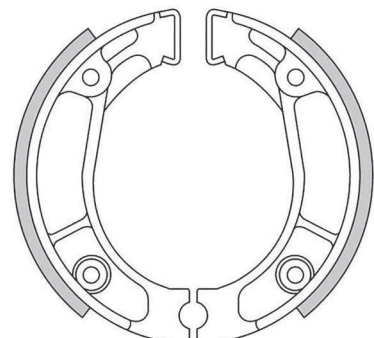

HONDA	Year	A/P
MB 50	80->82	P

... segue HONDA	Year	A/P
MBX 50 SD - SF	83->85	P
MT 50	80->93	A / P
MTX 50 S	83->	A / P
MXR 50		P
NSR 50 F - S	89->95	P
NSR 50 R	97->00	P
NSR 50 V - X	97->99	P
XL 50		A / P
XR 50 R	01->03	A / P
NSR 75 FII	88->	P
XR 75	75->78	A / P
CR 80 R	80->81	A / P
MBX 80	82	P
MBX 80 FWD	83->86	P
MBX 80 VOLLUERKLEIDUNG	85->	P
MCX 80 all models	82->	P
MT 80 all models	80->	A / P
MTX 80 all models	83->84	A / P
XR 80	80->84	A / P
XR 80 R	89->	A / P
C 90	82->03	A / P
YUPI 90	92->	P
CB 100 N	78->80	P
XL 100 all models	78->82	A / P
CT 110	80->04	P
CT 110	89->09	A
CB 125 J	79->	P
CG 125	98->03	P
CLR 125 CITY FLY	98->03	P
CR 125 M2 - 3 - 4	76->78	A / P
CT 125	76->85	A / P
MTX 125 R	83->84	A
MTX 125 R	83->86	P
NX 125	88	P
NX 125 TRANSCITY	89->97	P
TL 125	76	A / P
XL 125	78->82	A / P
XL 125 PARIS DAKAR	89->	P
XL 125 R	84->86	P
XL 125 R PARIS DAKAR	85->	P
XR 125 L	03->08	P
CRF 150 F	03->17	P
XL 185	80->82	A / P
CTX 200 A BUSHLANDER	04->05	P
MTX 200 RW	85->86	P
MTX 200 RWD	83->84	A / P
TL 200	76->79	A / P
TLR 200	86->87	A
XL 200 R	83->84	A / P
XR 200 R	80->02	A / P
CRF 230	04->09	P
RTL 250 SG	86->	A / P
RX 250 RE	84->	P
TL 250 F	85->	A / P
TLR 250	85->	A / P
XL 250 R	84->87	P
XL 350 R	83->84	P
XR 350 R	83->84	P
XR 500 R	84->85	P
XR 600 R	85->90	P

GF1179

STD

øt (mm): 130 (mm): 25

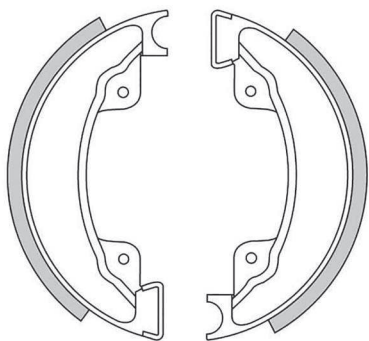

HONDA	Year	A/P
XL 500 R - RC	82	A
XL 500 R PARIS DAKAR	83->	A

GF1180

STD

øt (mm): 100 (mm): 20

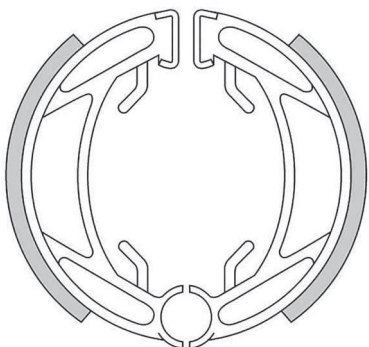

MOTOBECANE	Year	A/P
all models 50 (mozzi atom)	88->89	P
all models 50 (mozzi leleu)	88->89	P

GF1181

STD

øt (mm): 124 (mm): 28

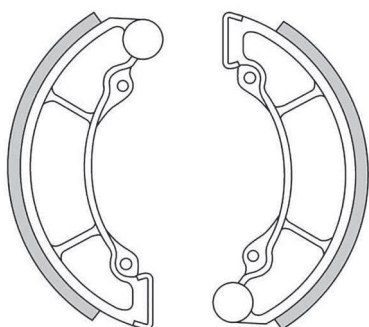

APRILIA	Year	A/P
RX 125 (mozzi Rimoldi)	84->85	P
RX 250	83	P
CAGIVA	Year	A/P
WMX 125 (mozzi Rimoldi)	84->	A
HRD	Year	A/P
RP 80 CROSS	83->	A / P
TRE SOLDI	Year	A/P
80		A / P
VALENTI	Year	A/P
125		A / P

GF1182

STD

øt (mm): 124 (mm): 28

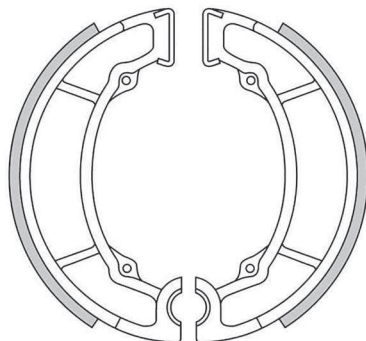

APRILIA	Year	A/P
TUAREG 125 RALLY(Mozzi Rimoldi)	86->	P
TUAREG 250 RALLY (Mozzi Rimoldi)	86->88	P
GILERA	Year	A/P
R1 50	90->	P
HX 250 LC	83->	P
RX 250 ARIZONA RALLY	86->	P
KRAMER	Year	A/P
80		A / P
VALENTI	Year	A/P
80		A / P

GF1183

STD

øt (mm): 150 (mm): 30

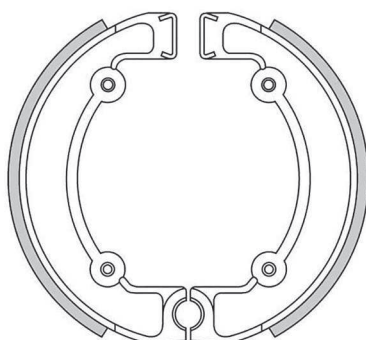

OSSA	Year	A/P
CROSS 125	74->	P
CROSS 250	74->	P
FUEGO 250	74->	P

GF1184

STD | FTR

øt (mm): 130 (mm): 25

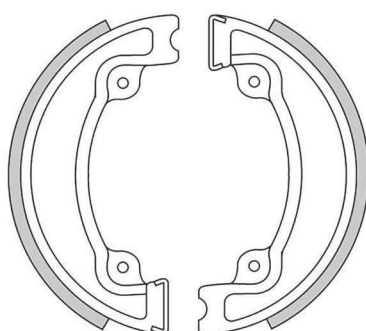

CAN AM	Year	A/P
DS 50 MINI	02->07	P
QUEST 50 2T	03->	P
DS 90 MINI 2T / 4T	02->07	P

...GF1184	Year	A/P
... segue CAN AM		
QUEST 90 4T	03->	P

E-TON	Year	A/P
JXL E 40 VIPER JNR	03->05	P
DXL 90 RANGER	03->04	P

HONDA	Year	A/P
TRX 70 FOURTRAX	86->87	P
CG 125	85->03	A
CH 125 SPACY	94->	P
CR 125 R	79->81	P
NX 125	88	A
CH 250 ELITE	87->90	A / P
CN 250	93->94	P
CN 250 ELITE	87->90	A / P
CR 250 R	81	P
XL 250 R	81->83	A
XLX 250	84->	A

MALAGUTI	Year	A/P
CIAK 125	00->01	P
CIAK 125 MASTER	04	P
CIAK 125 MASTER EURO 3	06	P
CIAK 125 RESTYLING	03	P
CIAK 150	00->02	P
CIAK 150 MASTER	03	P
CIAK 150 RESTYLING EURO 2	04	P
CIAK 200 MASTER EURO 2	06	P

GF1185

STD

øt (mm): 130 (mm): 22

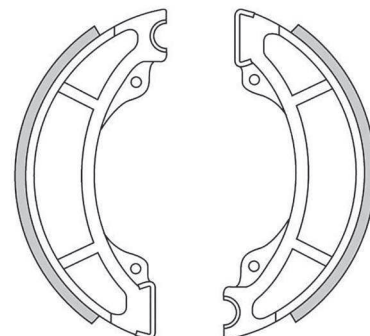

HUSQVARNA	Year	A/P
WRE 125	89->94	P
WRK 600	89->	P

KTM	Year	A/P
SX 60	98->00	P
MX 80	89->90	P
MX 80 GR - SUPER MINI	86->88	P
125 BAJA	86	P
GS 125	84->85	A / P
GS 125 LC	83	A
MX 125	83->86	P
MX 125	84	A
BAJA 250	86->	P
GS 250	83->84	A / P
MX 250	84	A / P
GS/MX/ MXC 300	85	P
COUNTRY 350	85->	P
GS 420	84->	A / P
MX 495	84	A / P
MX 500	83->84	A / P
MX/MXC 500	85	P
GS 600	84	A / P
XC/XCE 600	85	P

FIGURATO GANASCE CON APPLICAZIONI | BRAKE SHOES DRAWINGS AND APPLICATIONS | DESSINS MÂCHOIRES DE FREIN AVEC APPLICATIONS |
 DISEÑOS MORDAZAS CON RELACIÓN | ZEICHNUNGEN VON BREMSBACKEN MIT VERWENDUNGSLISTE



GF1186
STD

øt (mm): 150 (mm): 28

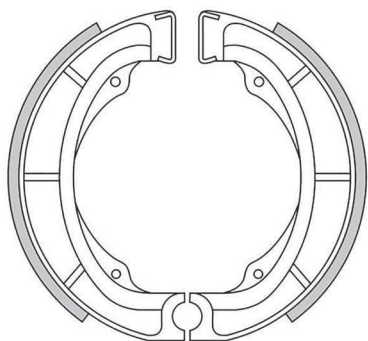

KAWASAKI	Year	A/P
KDX 250	79->80	P
KL 250	78->79	P
KX 250	74->81	P
KX 420 A1 - A2	80->81	P

SUZUKI	Year	A/P
ALT 125	84->86	P
LT 125	84	P
LT 160	89->92	P
LT 160 QUADSPORT	03->04	P
LT-F 160	90->03	P
ALT 185 F	85	P
LT 185	84->85	P
SB 200	79->80	A
SX 200	90->91	P
LT 230 GEF/GEG	85->86	P
LT-F 230 G/H	86->87	P
PE 250 B - C	77->78	A/P
PE 250 T	80	A/P
PE 250 X - Z	81->82	P
RM 250	76->78	P
RM 250	79	A
TS 250 all models	74->82	A/P
TS 250 X all models	85->89	P
SP 370 C - N	78->79	A/P
DR 400 ST - SX	79->81	A/P
LS 400 SAVAGE	87->	A/P
PE 400 T	80->81	A/P
RM 400	78	P
RM 400	79	A
SP 400	80	A/P
ST 400	79->	A/P
SX 400	79->	A/P
DR 500 S	84->88	A/P
DR 500 SD - SE	81->83	P

GF1187
STD | FTR | PRO

øt (mm): 110 (mm): 25

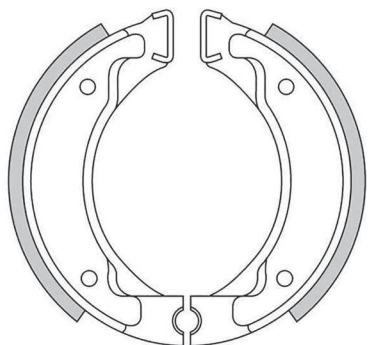

MBK	Year	A/P
ACTIVE 50	90->	A
BOOSTER 50	->94	A/P

...GF1187

... segue MBK	Year	A/P
CW 50 BOOSTER SPIRIT	96->99	P
CW 50 R BOOSTER ROAD	94->95	P
CW 50 RSP BOOSTER ROCKET	97->98	P
CW 50 RSX TRACK	96->98	P
FLIPPER 50	98->	P
YA 50 R FORTE	94->96	P
YM 50 FIZZ	94->95	P
ACTIVE 75	90->	A
ACTIVE 80	90->	A

YAMAHA	Year	A/P
BELUGA 50	90->	A
BREEZE 50 YM	94->96	P
BW 50	91->	A/P
BW 50 BUMP	97->	P
BW 50 NEXT GENERATION	96->	P
BW 50 SPORTS SPEC R	02->	P
BW 50 SPY	00->	P
BW S 50	92->94	A/P
BW S 50 R	95->96	P
DT 50 MX	87->91	A/P
FS 1 50	87->90	A/P
GRAFIX 50	93->	A/P
JOC 50	90->	A/P
JOG 50 CY	88->	P
MINI 50 L SHAFT	83->	P
T 50 TOWNMATE	86	A/P
TRAFIC 50	93->	A/P
V 50 M	83->	A/P
WHY 50	97->	P
ZUMA 50	90->95	A/P
YS 60 S (MOTO4)	86	P
YT 60 L/N TRI ZINGER	84->85	P
80 BELUGA	90->	A
DT 80 (España)		A/P
DT 80 LC (España)	89->	P
DT 80 MX Type 36N	83->85	A/P
DT 80 MXS	84	A/P
T 80 TOWNMATE	83->97	A/P
V 80 DL	83->	A/P
YFM 80	87->88	A
RX S 100	83->97	A/P
YFM 100 CHAMP	87->88	A
CRYPTON 105 T	96->97	A/P
V 110 SPORTY	96	P
RX 115	99	P
SR 125 SE	92->96	P

GF1188
STD | FTR

øt (mm): 110 (mm): 25

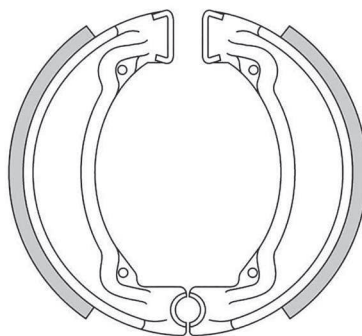

CPI	Year	A/P
POPCORN 50	03->05	P

GARELLI	Year	A/P
PONY 50	92->	A/P
PONY 50 SR	92->	P

...GF1188

HONDA	Year	A/P
CN 250 HELIX	86->87	P

YAMAHA	Year	A/P
CHAPPY 50	80->	A/P
DT 50 M	78->86	A/P
DT 50 MX	78->86	A/P
FS 1 50 DX	79->80	P
FS 1 50 E	74->75	A/P
FS 1 50 E DX	77->79	P
FS 1 50 SE	81->82	A/P
LB 2 50 M CHAPPY	80->	A/P
LC 50 M	80->	A/P
RD 50 M	78->80	P
RD 50 MX	81->87	P
TY 50 M	77->80	A/P
V 50 M - P	74->82	A/P
V 70 A	76->	A/P
DT 80 MX Type 12X	83	A/P
DT 80 MX Type 5J2	81->82	A/P
FS 80 SE	81->	A/P
LB2 80 BOP	80->	A/P
RD 80 AIR COOLED	82	P
RD 80 LC2 - LCS	82	P
RX 80 SE	82->	P
TY 80	77	P
V 80	79->82	A/P
YZ 80	77->79	P
V 90	78	A/P
DT 100	76->80	A
RS 100	75->80	A/P
RS 100 DX	77->80	P
YB 100	78->81	P
YB 100	78->86	A
YZ 100	78->81	A
IT 125 G - H - J	80->82	A
TY 125	80->82	A
TY 175	77->80	A
TY 250	77->80	A
TY 250 R	91->92	P
TY 250 S - RS	84->90	P

GF1190
STD | FTR

øt (mm): 180 (mm): 30

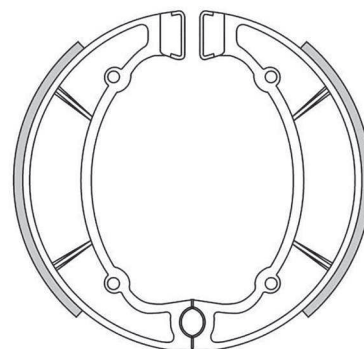

YAMAHA	Year	A/P
RD 250	74->76	P
RD 250 LC	80->83	P
RZ 250 (4L3)		P
RD 350 LC	80->82	P
RD 350 S	74->76	P
XS 360 B	75	P
XS 650	75->81	P
YDS-7 700	73->	P

GF1191

STD

øt (mm): 180 (mm): 32

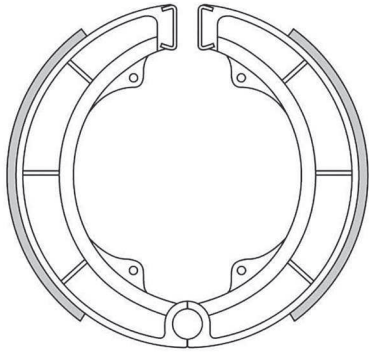

SUZUKI	Year	A/P
GS 550 B - C - D	77->78	P
GT 550 A - B	76->77	P

GF1192

STD

øt (mm): 140 (mm): 40

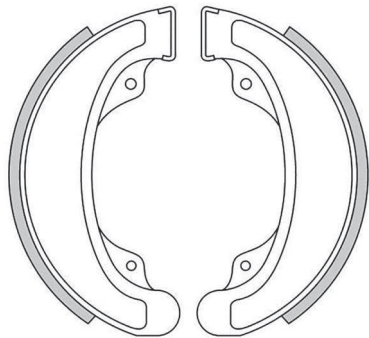

HONDA	Year	A/P
CB 250	78->91	P
CM 250 TB	81	P
CB 350 SG	86->88	P
CB 400 A - HAWK	78->	P
CB 400 N - NA - NB	78->82	P
CB 400 N/F	83->	P
CM 400	78->	P
CB 450 N	85->	P
CBX 450 S	87->	P
CMX 450 CG REBEL	86->	P
VT 500 CD - FT	82	P
VT 500 ED - EF - C	83->85	P

GF1193

STD

øt (mm): 80 (mm): 17

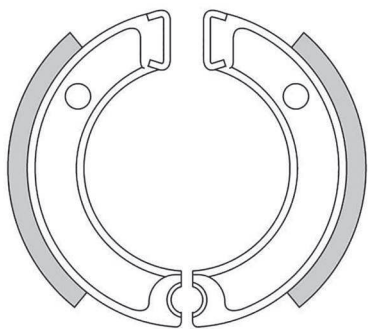

MBK	Year	A/P
CHAMP 50		A / P

...GF1193

YAMAHA	Year	A/P
MA 50 M	81->	A / P
MINT 50	96->	A
MJ 50 M TOWNY	81->93	A / P
MS 50	85->	A
PW 50 H - J - K	80->	A / P
PW 50 H1	96->00	A / P
QA 50 POCHE	83->	A / P
QB 50 VOGEL	83->	A / P
QT 50	80->	A / P
SA 50 M - ME PASSOLA	80->	A
SALIENT 50 CA	83->	A
SH 50 RAZZ	93->	A

GF1194

STD

FTR

øt (mm): 130 (mm): 30

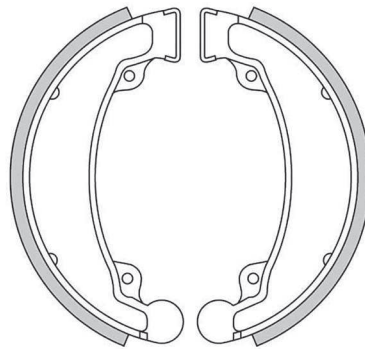

DAELIM	Year	A/P
DELFINO 50	99->	P
TAPO 50	99->	P
VIVO 50	99->	P
DELFINO 100	99->	P
ROCKET 125	99->	P
VT 125 EVOLUTION	00->	P

HONDA	Year	A/P
ATC 70 all models	78->85	P
CB 125 K1 - K5	72->76	P
CB 125 K6 - S2	76->77	P
CB 125 RS	83	P
CB 125 T	78	P
CB 125 T2 - TA - TB	79->	P
CB 125 TDJ	87->89	P
CB 125 TT	90->	P
CD 125	78->	P
CM 125	82->85	P
CD 185 T	78	P
CD 200 T	79->80	P
CM 200 TA - TB	79->80	P
CB 250 NIGHT HAWK	91->	P
CB 250 TWO FIFTY	92->05	P
CD 250	88->92	P
CM 250 C	82->	P
CMX 250 C REBEL	96->00	P

GF1195

STD

øt (mm): 160 (mm): 30

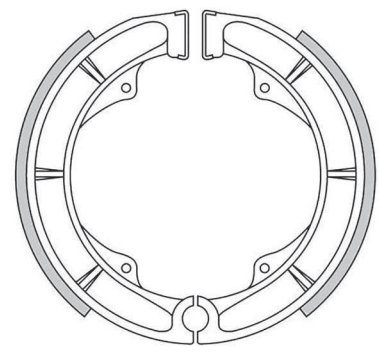

SUZUKI	Year	A/P
GNX 250 E	83->	P
GS 250 E	80->81	P
GSX 250	80->82	P
GT 250 EN - ET - EX	79->81	P
GN 400 TT	80->	P
GSX 400 ET - EX - EZ	80->82	P
LT-A 400 EIGER	02->07	P
LT-F 400 EIGER	02	P
LT-F 400 EIGER 2WD	03->07	P
GS 425 EN	78->	P
GS 450 E	80->88	P
LS 650	05->	P
LS 650 P SAVAGE	87->04	P

GF1196

STD

øt (mm): 110 (mm): 25

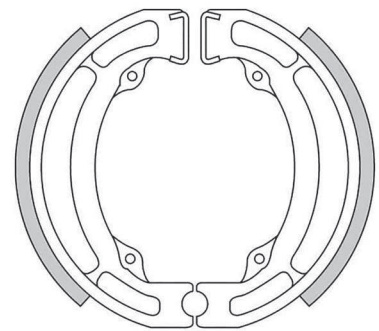

KAWASAKI	Year	A/P
KLX 125	03->06	A / P
KLX 125 L	03->06	P

SUZUKI	Year	A/P
GS 50	05	A / P
LT-A 50 QUADMASTER	01->05	P
LT-Z 50	06->20	P
OR 50 ET	80	P
RB 50 H	87	P
RM 50	81->82	A / P
TS 50	80->83	P
ZR 50	84->87	P
ZR 50 SLK	81	P
DS 80	80->00	A / P
JR 80	01->07	A / P
RM 80	80->81	A / P
RM 80 HD - HF	83->85	P
LT-Z 90	07->20	A
TS 100	82->87	P
DR Z 125 K	03->12	A / P
DR Z 125 L	03->20	P
TS 125 ERZ - FFS	82	P

FIGURATO GANASCE CON APPLICAZIONI | BRAKE SHOES DRAWINGS AND APPLICATIONS | DESSINS MÂCHOIRES DE FREIN AVEC APPLICATIONS |
DISEÑOS MORDAZAS CON RELACIÓN | ZEICHNUNGEN VON BREMSBACKEN MIT VERWENDUNGSLISTE



GF1197
STD

øt (mm): 160 (mm): 30

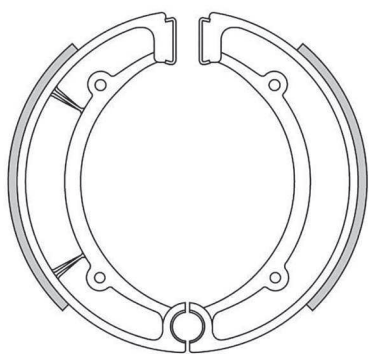

YAMAHA	Year	A/P
YFM 50 F BIG BEAR	96->98	P
MAJESTY 250 YP	96->98	P
XS 250 C	81	P
XS 250 D - E	79->81	P
XS 250 SE - SF SPECIAL	79->81	P
YFM 350 FW BIG BEAR	96->98	P
YFM 350 L BIG BEAR	99->	P
XS 400	79->	P
XS 400 SE	80->81	P
YFM 400 F KODIAK AUTO	03->04	P
YFM 400 FP BIG BEAR 4WD	03->04	P
YFM 400 FW KODIAK	93->99	P
YFM 400 FWP BIG BEAR 4WD	02	P
XJS 550 SECA	81->83	P
YFM 600 GRIZZLY 4x4	98->01	P
YFM 600 GRIZZLY HUNTER EDITION	01->	P
YFM 600 GRIZZLY HUNTING	00->	P

GF1198
STD

øt (mm): 95 (mm): 20

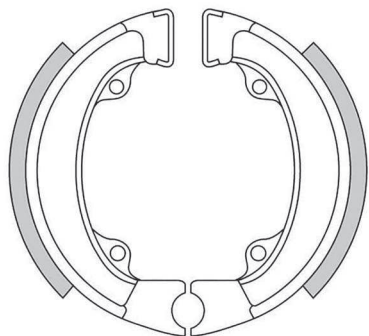

HERCULES	Year	A/P
LIMBO 50	93->	A

HONDA	Year	A/P
NB 50	85->	P
NB 50 DELUX	82->	P
NB 50 MELODY	82->	P
NB 50 MSB	82->	P
ND 50	82->	P
ND 50 MELODY 2 all models	82->	P
NE 50 VISION	85->	P
NH 50 LEAD	->93	P
NH 50 LEAD (disk)	88->92	P
NP 50 D MELODY MINI	83->	P
NU 50 MC RUNAWAY	82->	P
NV 50 MSD STREA	84->	A/P
NX 50 A	82->	P
NX 50 B	82->	P
NX 50 MB CAREN	82->	P
OR 50	93->	P
PX 50 all models	82->83	P

...GF1198

... segue HONDA	Year	A/P
QR 50 ED	82->	P
SA 50 ELITE LX	88->90	P
NH 80 LEAD	83->88	P

PEUGEOT	Year	A/P
METROPOLIS 50		P
SC 50		P
ST 50		P
STL 2 50		P
SC 75		P
SX 75		P
METROPOLIS 80		P
SX 80		P

PGO	Year	A/P
STAR 50	->93	P
STAR 2 50	94->	P
BIG MAX 80		P
STAR 80	90->	P

SYM	Year	A/P
FIDDLE 50	99->	P
MIO 50	05->07	P

GF1199
STD | FTR

øt (mm): 95 (mm): 20

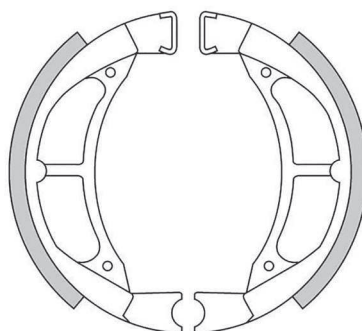

SUZUKI	Year	A/P
RM 80	82->89	P

YAMAHA	Year	A/P
YZ 50	80->83	A/P
YZ 60	85	A/P
PW 80	83->91	P
PW 80	83->12	A
TY 80	77->	A
YZ 80	77->85	A
YZ 80	80->89	P
TT R 90	00->08	A
TT R 110 EX/EY	08->20	A

GF1200
STD | FTR | PRO

øt (mm): 110 (mm): 25

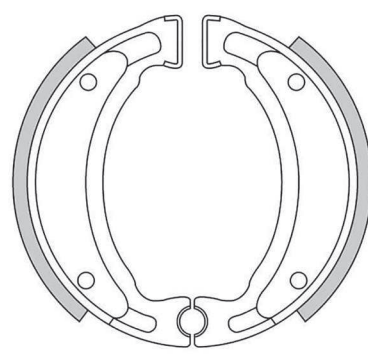

ADLY	Year	A/P
SILVER FOX 25	00->05	P
FOX 50	00->	P
JET 50	96->	P
PISTA - TWIN LIGHT 50	96->	P
SILVER FOX 50	00->05	P
JET 100	96->	P
SILVER FOX 100	06->	P

BRANDY-BRAS	Year	A/P
BRANDY 50		P
BRANDY 90		P

CPI	Year	A/P
BABY 50 J	02->	P
HUSSAR 50	01->05	P
MARS 50	01->02	P
OLIVER 50 all models	03->05	P
POPCORN 50	02	P

FANTIC	Year	A/P
PONY 50	93->	A/P
PONY 50 SR	93->	P
QUEENIE 50	95->	P

GENERIC	Year	A/P
IDEO 50	05->	P
XOR 50	05->	P
IDEO 125	05->	P
XOR 125	05->	P

ITALJET	Year	A/P
ADLY 50	90->	P

KAWASAKI	Year	A/P
BN 125	98->99	P

KEEWAY	Year	A/P
50 HURRICANE	06->16	P
50 MATRIX	06->15	P
F-NKD 50	10->11	P
FLASH 50	07->12	P
FLASH 50 ELECTRIC	10->12	P
RY8 50	07->09	P

KOTIR	Year	A/P
RS 50	90->	A/P

KREIDLER	Year	A/P
FLORETT 50 XL	99->06	P

LEM	Year	A/P
FLASH 50	94->	P
GHIBLI 50	90->	A/P

MAICO	Year	A/P
C 1 50 HARD ENDURO	99->	P
CLASSIC 50	99->	A/P
CRUISER 50	99->	P

...GF1200		
... segue MAICO	Year	A/P
R 1 50 SUPERBIKE	99->	P
THUNDERBIKE 50 I	99->	P
THUNDERBIKE 50 II	99->	P
TRAFICJAMMER 50	99->	A / P
X 1 50 SUPERCROSS	99->	P

MALAGUTI		
Year	A/P	
F 10 50 AC	08	P
F 10 50 AC ECO	09->10	P
F 12 R 50 PHANTOM AC	07->10	P

MBK		
Year	A/P	
CR Z 50 TARGET	91->95	P
CS 50 MACH G	02->	P
CW 50 BOOSTER	01->	P
CW 50 BOOSTER NG	99->	P
CW 50 L BOOSTER	01->	P
CW 50 RS BOOSTER NG	95->03	P
EW 50 STUNT	00->02	P
OVETTO 50	97->	P
ROCKET 50	96->	P
SORRISO 50	92->97	A / P
X-LIMIT 50	98->00	P
YE 50 EVOLIS	92->95	P
EVOLIS 80	94->	P
XC 125 FLAME	98->	P
XC 125 FLAME R	96->99	P

POLARIS		
Year	A/P	
SCRAMBLER 2 (3 wheeler)	85->86	A
TRAIL BOSS 2	85->87	A
CYCLONE X 250	87	A

RAPIDO		
Year	A/P	
SCRENNIA 50		P

SULA		
Year	A/P	
CITY BIRD 50	99->	P
THUNDER BIRD 50	99->	P
THUNDER BIRD 100	99->	P
THUNDER BIRD 125	99->	P

YAMAHA		
Year	A/P	
BW 50 SPY	95->99	P
CR 50 TARGET	91->	P
CR 50 Z	92->	P
CT 50 SUPER SPORT	90->	A / P
DT 50 MX	92->95	A / P
DT 50 R	97->01	P
NEOS 50 YN	97->16	P
RZ 50 (5FC1/2)	02	P
YFM 50 RAPTOR	04->09	A
YSR 50	86->	P
ZEST 50 YE	92	P
YSR 60	86->	P
80 BELUGA	->89	A / P
PW 80	93->12	P
TY 80	83->	P
YFM 80 BADGER	92->01	A
YFM 80 GRIZZLY	05->08	A
YFM 80 RAPTOR	02->08	A
YSR 80	86->	P
CR 90 TARGET	91->	P
TT R 90	00->08	P
AG 100 E FARM BIKE	93	A
AG 100 J	82	A
RT 100	94->03	A / P
YB 100	82->92	P
YB 100	87->92	A
YFM 100 CHAMP	89->91	A
YZ 100	82->83	A
TT R 110 EX/EY	08->20	P
CYGNUS R 125 XC	99->03	P
CYGNUS R 125 XC K	97->98	P
CYGNUS R 125 XCT	95->98	P

...GF1200		
... segue YAMAHA	Year	A/P
SR 125	82->03	P
TT R 125	00->09	A / P
TT R 125 LW	00->20	P
TW 125	99->02	P
XT 125	82->83	P
YFA 1 125 BREEZE	89->02	A
CYGNUS GT 150 XC	90->95	P
YT 175 TRI MOTO	82->83	A
AG 200 E	93	A
TW 200	87->02	P
YFM 200 MOTO 4	85->90	A
YFS 200 BLASTER	88->02	A
YTM 200 TRI MOTO	89	A
ST 225 BRONCO	97	P
TT R 225	01->	P
XT 225	97->06	P
XT 225 SEROW	85->92	P
YFM 225 MOTO 4	86->88	A
YTM 225 TRI MOTO	85->86	A
YFB 250 D/E/F TIMBERWOLF	92->94	A

GF1201		
STD	FTR	
øt (mm): 140 (mm): 20		

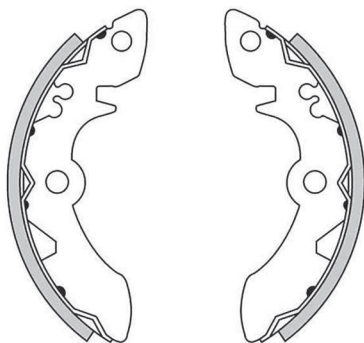

SUZUKI		
Year	A/P	
LT 230 GEF/GEG	85->86	A
LT-F 230 G/H	86->87	A
LT 250 EFF/EFB	85->86	A

GF1202		
STD		
øt (mm): 180 (mm): 40		

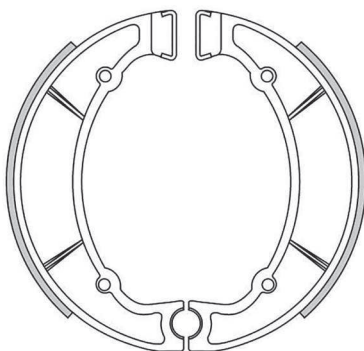

YAMAHA		
Year	A/P	
TX 500	75->77	P
XS 500 B	75	P
XV 500 SE	83->	P
XJ5 550	81->84	P
XJ5 550 MAXIM	81->84	P
XZ 550	82->84	P
XZ S 550	85->	P
YX 600 RADIAN	86->90	P
XJ 650 MAXIM	80->83	P
XJ 650 MIDNIGHT	81	P

...GF1202		
... segue YAMAHA	Year	A/P
XV 750 SE	81->	P
XV 750 VIRAGO	92->93	P

GF1203		
STD		
øt (mm): 180 (mm): 30		

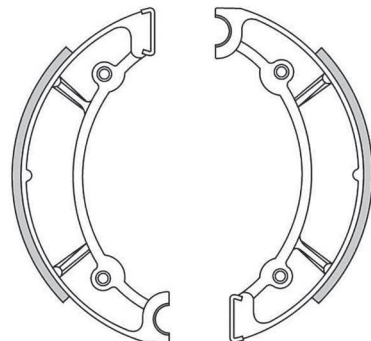

YAMAHA		
Year	A/P	
XS 250 C	81	A
YDS-7 700	73->	A

GF1204		
STD		
øt (mm): 200 (mm): 40		

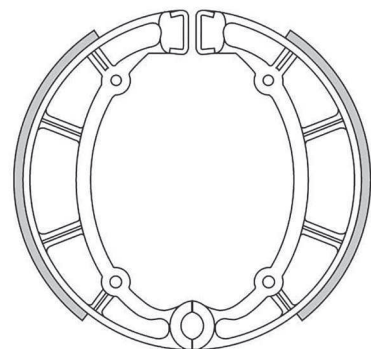

YAMAHA		
Year	A/P	
XV 400 VIRAGO	88->	P
XVS 400	98->99	P
XV 535 DX VIRAGO	01->03	P
XV 535 VIRAGO	87->01	P
KJ 650	80->	P
XJ 650	80->84	P
XJ 650 SECA	82	P
XJ 650 TURBO	83->	P
XVS 650 A DRAG STAR CLASSIC	98->07	P
XVS 650 DRAG STAR	97->04	P
XJ 750 SECA	81->83	P
XV 750 VIRAGO	94->97	P
XV 1000 SE MIDNIGHT SPECIAL	83->	P
XV 1000 SE VIRAGO	88	P
XV 1000 TR 1	81	P
XV 1000 VIRAGO	86	P
XV 1100 VIRAGO	86->98	P



GF1205 STD

øt (mm): 100 (mm): 20

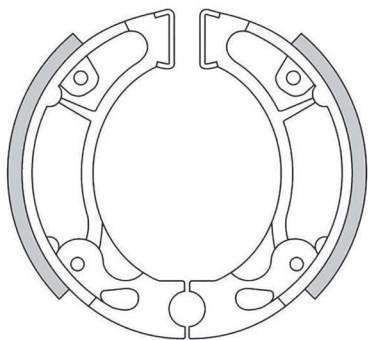

HONDA	Year	A/P
CR 50 R	84->85	A / P
NU 50 MC RUNAWAY	82->	A
CR 80 R	82->84	P
CR 80 R	83->84	A

GF1206 STD | FTR

øt (mm): 140 (mm): 28

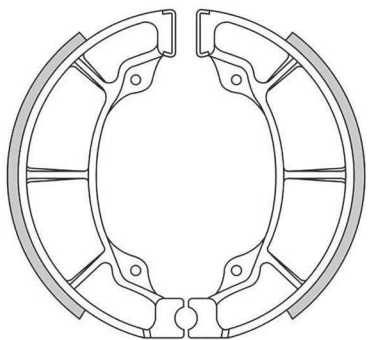

HONDA	Year	A/P
TRX 90	93->11	P
ATC 110 all models	79->84	P
ATC 125 M	84->85	P
TRX 125 FOURTRAX	85->87	P
TRX 125 J	88	P
CD 175 all models	71->78	A
ATC 185	80->83	P
ATC 200	81->83	P
ATC 200 M	84->85	P
TRX 200 FOURTRAX	84->97	P
TRZ 200 (4W)	90	P
ATC 250 ESF/ESG/ESH/ESJ	85->88	A
ATC 250 R	81	P
FL 250 ODYSSEY	77->84	P

POLARIS	Year	A/P
PHOENIX 200	06->20	P
SAWTOOTH 200	06->08	P

GF1207 STD

øt (mm): 130 (mm): 28

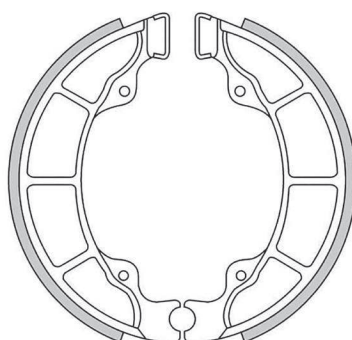

CAN AM	Year	A/P
DS 70	02->07	P
DS 90 MINI 4T	08->20	P

HONDA	Year	A/P
CD 175 all models	71->78	P

POLARIS	Year	A/P
OUTLAW 50	08->19	P
PREDATOR 50	03->07	P
SCRAMBLER 50	01->03	P
OUTLAW 90	08->14	P
PREDATOR 90	03->06	P
SCRAMBLER 90	01->12	P
SPORTSMAN 90	01->16	P
OUTLAW 110	16->19	P
SPORTSMAN 110	12->19	P

SYM	Year	A/P
ATTILA 125	99->00	P
SHARK 125	99	P

GF1208 STD

øt (mm): 160 (mm): 30

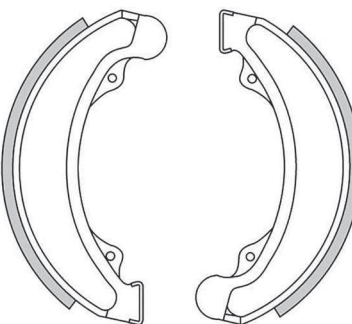

HONDA	Year	A/P
CB 125 K1 - K5	72->76	A
CB 175 all models	74->76	A

GF1209 STD

øt (mm): 160 (mm): 25

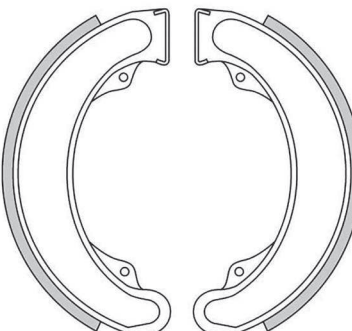

HONDA	Year	A/P
XL 250	78->79	A

GF1210 STD

øt (mm): 180 (mm): 30

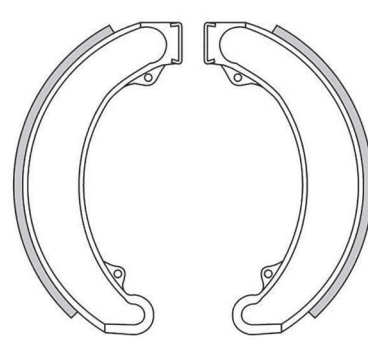

HONDA	Year	A/P
CB 250	73->75	A
CB 350 K4		A
CB 360 G5 all models	75->	A

GF1211 STD | FTR

øt (mm): 200 (mm): 30

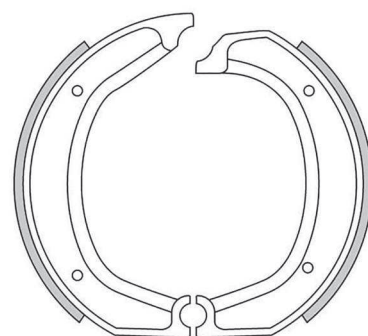

BMW	Year	A/P
R 45 450 (21_0068 - 248)(a 09/80)	78->80	P
R 45 N 450 (21_0068 - 248)(a 09/80)	78->80	P
R 50/5 500	69->73	P
R 60 TIC 600	78->82	P
R 60/5 600	69->73	P
R 60/6 600	73->76	P
R 60/7 600	76->80	P
R 65 650 (21_0068 - 248)(a 09/80)	78->80	P
R 75/5 750	69->75	P
R 75/5 750	76->80	P
R 75/6 750	73->76	P
R 75/7 750	75->79	P
R 80 800 (single disc)	77->84	P
R 80 800 (twin disc)	77->84	P
R 80 TIC 800 (21_0072 - 2474)(a 09/80)	77->80	P
R 90 900	73->76	P
R 90 S 900	73->76	P
R 90/6 900	73->76	P
R 100 1000 S	76->80	P
R 100 RS 1000 (21_0072 - 2474)(a 09/80)	76->80	P
R 100 RT 1000 (21_0072 - 2474)(a 09/80)	78->80	P
R 100/7 1000	76->77	P
R 100/7T 1000 (21_0072 - 2474)(a 09/80)	77->80	P

GF1212

STD

øt (mm): 160 (mm): 30

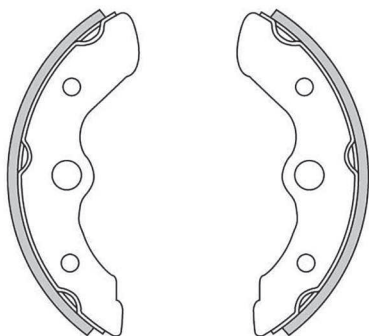

HONDA	Year	A/P
TRX 200 FOURTRAX	84	A
TRX 250	86->89	A
TRX 250 FOUTRAX	85->87	A
FL 350 R ODYSSEY	85->87	A
FL 400 R PILOT	89->93	A

GF1213

STD | FTR

øt (mm): 150 (mm): 25

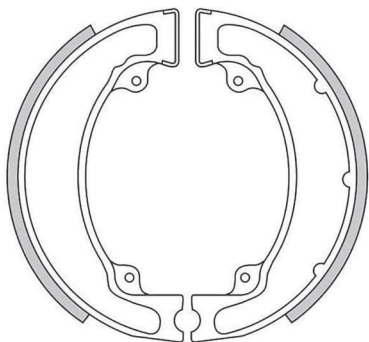

HONDA	Year	A/P
CR 250 R	->77	P
CR 450 R	81->	P

GF1214

STD

øt (mm): 160 (mm): 40

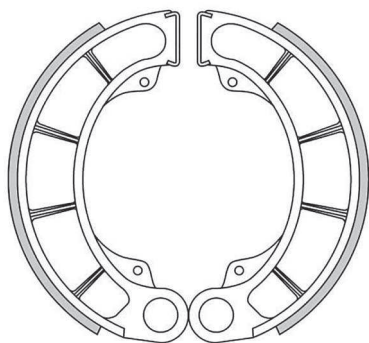

HONDA	Year	A/P
NV 400 C STEED	92->97	P
CB 500	94->96	P
CB 500 K1 - K2	75->77	P
CB 500 T	75->77	P
CX 500	79->81	P
GL 500 DC	82	P
GL 500 SILVER WING INTERSTATE	82->	P
NV 600 C	88->	P
VLX 600 SHADOW	88->91	P

...GF1214

... segue HONDA	Year	A/P
VT 600 C SHADOW	88->93	P
VT 600 C-CD SHADOW VLX	94->00	P
CB 650 SCC NIGHTHAWK	82	P
CB 650 SCD	83->	P
CBX 650 ED	83->	P
CX 650 ED	83->85	P
GL 650	84->	P
VF 700 C MAGNA	84	P
VF 700 S SABRE	84->	P
VT 700 C SHADOW	84->85	P
VF 750 C	93->99	P
VF 750 C SHADOW	83	P
VF 750 CH	87	P
VT 750 C SHADOW	83->85	P
VT 750 SHADOW SPIRIT	07->11	P

GF1215

STD | FTR

øt (mm): 140 (mm): 25

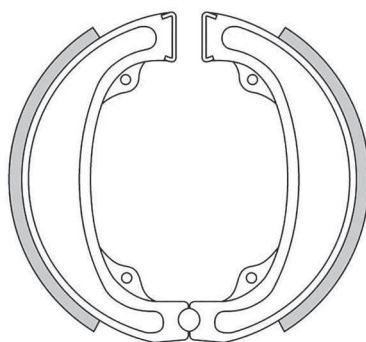

HONDA	Year	A/P
CR 125 R	79->81	A
CR 250 R	78->80	A
XR 500 S	79->80	A

GF1216

STD

øt (mm): 120 (mm): 28

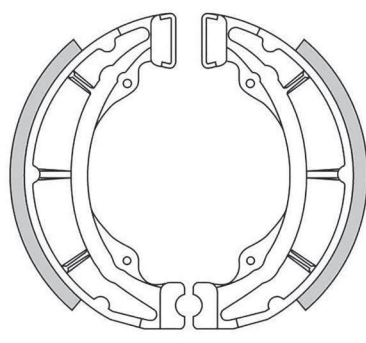

SUZUKI	Year	A/P
RG 50 GAG - GAMMA	87->	P
S 50 K	93->	A
TS 50	84->02	A
RM 100	79->81	P
RM 125	79	P
TS 125	88	P
TS 240 X	88->	P

GF1217

STD

øt (mm): 95 (mm): 20

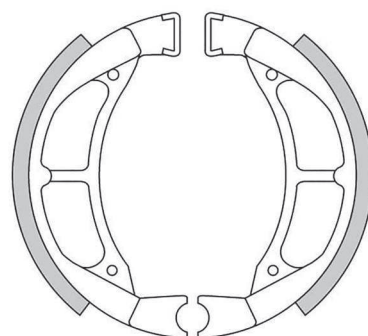

MBK	Year	A/P
ACTIVE 50	->89	A / P
ACTIVE 75	90->	P
ACTIVE 80	->89	A / P

YAMAHA	Year	A/P
BELUGA 50	89	A
BELUGA 50	89->	P
JOG 50 (Brasil)		P
JOG 50 (España)	88->	P
JOG 50 CY	88->	A
LC 50 M BOP	80->	A / P
MINT 50	96->	P
MS 50	85->	P
RS 50 CHAMP	88->	P
SA 50 M - ME PASSOLA	80->	P
SALIENT 50 CA	83->	P
SG 50 STING	84->	A / P
SH 50 RAZZ	93->	P
SPY 50	->02	P
ZEST 50 YE	93->97	P
80 BELUGA	90->	P
JOG 90	90->	P
JOG 90 (Brasil)		P

GF1218

STD | FTR

øt (mm): 200 (mm): 25

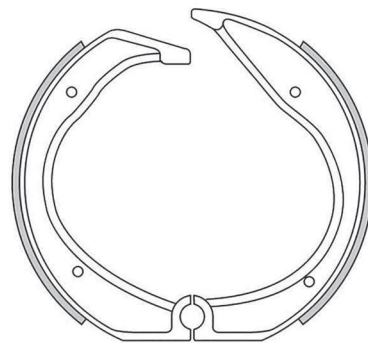

BMW	Year	A/P
R 45 450 (21_0067 - 248)(da 09/80)	80->85	P
R 45 N 450 (21_0067 - 248)(da 09/80)	80->85	P
R 45 T 450	80->85	P
R 45 T/N 450	80->85	P
R 65 650	89->	P
R 65 650 (21_0067 - 248)(da 09/80)	80->85	P
R 65 650 20 KW	85->93	P
R 65 650 35 KW	85->88	P
R 65 650 GS	87->92	P
R 65 RT 650	85->88	P
R 80 GS 800	80->86	P
R 80 R 800 (single disc)	84->95	P
R 80 R 800 (twin disc)	84->87	P
R 80 RT 800 (single disc)	84->95	P
R 80 RT 800 (twin disc)	82->87	P

FIGURATO GANASCE CON APPLICAZIONI | BRAKE SHOES DRAWINGS AND APPLICATIONS | DESSINS MÂCHOIRES DE FREIN AVEC APPLICATIONS | DISEÑOS MORDAZAS CON RELACION | ZEICHNUNGEN VON BREMSBACKEN MIT VERWENDUNGSLISTE



...GF1218		
... segue BMW	Year	A/P
R 80 ST 800	82->84	P
R 80 TIC 800 (21_0067 - 2474)(da 09/80)	80->85	P
R 100 CS 1000	80->84	P
R 100 RS 1000 (21_0067 - 2478)	86->87	P
R 100 RT 1000	87->88	P
R 100 TIC 1000	80->84	P
R 100/7T 1000 (21_0067 - 2474)(da 09/80)	80->84	P

GF1219 STD

øt (mm): 200 (mm): 25

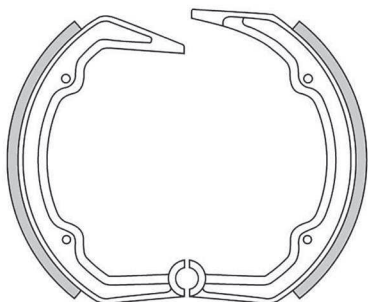

BMW	Year	A/P
R 65 650 LS	81->85	P

GF1223 STD | FTR

øt (mm): 95 (mm): 20

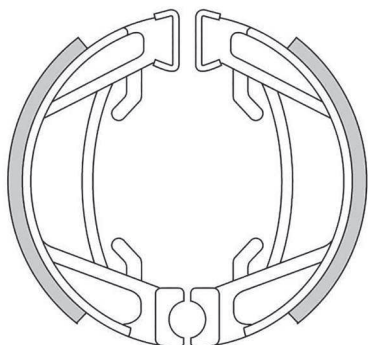

HONDA	Year	A/P
PX 50 E	84->	P

GF1224 STD

øt (mm): 200 (mm): 40

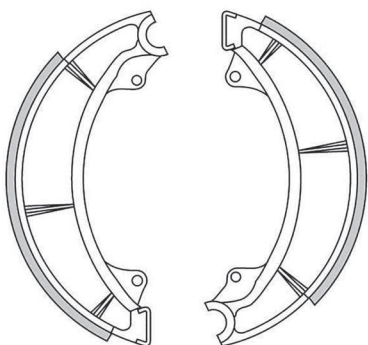

KAWASAKI	Year	A/P
BJ 250 ESTRELLA CUSTOM	96->02	A

SUZUKI	Year	A/P
T 500 all models	68->75	A
GT 550 J	72->	A

GF1225 STD

øt (mm): 90 (mm): 20

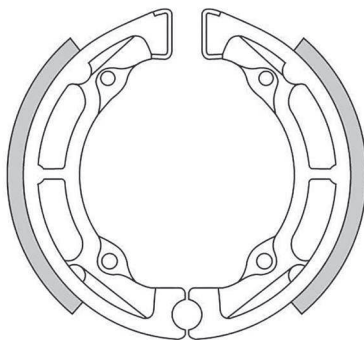

KAWASAKI	Year	A/P
KDX 50	03->06	A/P

SUZUKI	Year	A/P
ALT 50 D/E	83->84	P
CL 50 D LOVE	83->	P
CL 50 D SUZY	83->	P
CS 50 D	83->	A/P
CS 50 Z ROADIE	83->	A/P
LT 50	84->87	P

GF1226 STD

øt (mm): 80 (mm): 20

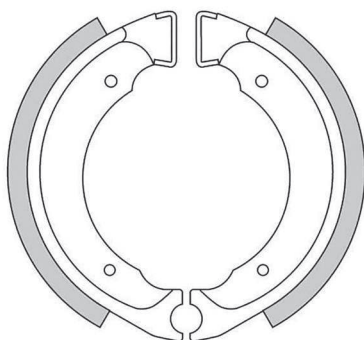

SUZUKI	Year	A/P
CARNA 50	90->	A
CL 50 D LOVE	83->	A
CL 50 D SUZY	83->	A
F 50 SUZY		A/P
FS 50 T - X SNIP	81->	A/P
LT-A 50 QUADMASTER	01->05	A
LT-Z 50	06->20	A
LT 80 all models	87->01	A

GF1227 STD | FTR

øt (mm): 100 (mm): 20

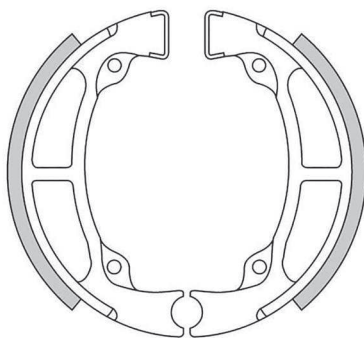

SUZUKI	Year	A/P
RM 80	82->85	A

GF1228 STD

øt (mm): 120 (mm): 30

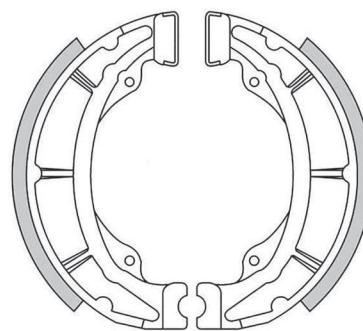

SUZUKI	Year	A/P
TS 80 X	84->	A
RM 125	80	P
TS 125	84->87	P
TX 125 XF	85->	P

GF1229 STD | FTR

øt (mm): 110 (mm): 25

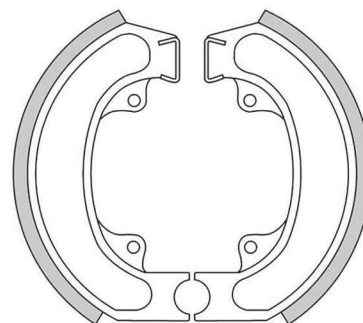

HONDA	Year	A/P
SH 50	84->94	P
SH 50	88->94	A
SH 75 SCOOPY	88->	P
SH 80	84->	P
SH 80 SCOOPY	88->	P
LEAD 90 A		P
LEAD 90 L - M		P

GF1230 STD | FTR

øt (mm): 180 (mm): 36

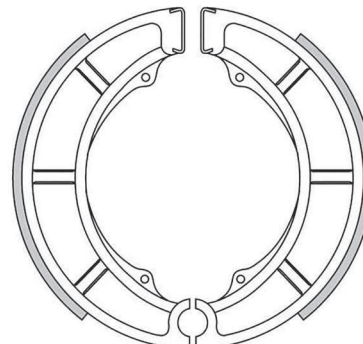

SUZUKI	Year	A/P
LT-F 300 KING QUAD	02	P
LT-A 400 KING QUAD 4WD	08->12	P
VS 400 INTRUDER	94->	P
VS 600 GL INTRUDER	95->97	P
GV 700 GL MADURA	84->	P
VS 700 GL INTRUDER	85->	P
VS 700 GLE	86->87	P

...GF1230		
... segue SUZUKI	Year	A/P
VS 750 GL	85->91	P
C 800 INTRUDER	05->12	P
M 800 INTRUDER	05->12	P
VL 800 INTRUDER LC VOLUSIA	01->04	P
VS 800 INTRUDER	92->99	P
VS 800 S INTRUDER	91->99	P
VZ 800 MARAUDER	97->03	P

GF1231 STD
øt (mm): 140 (mm): 28

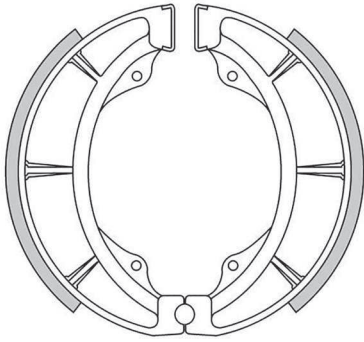

SUZUKI	Year	A/P
DR 250 S	83->84	A
RM 250	79	P
RM 400	79	P

GF1232 STD
øt (mm): 180 (mm): 35

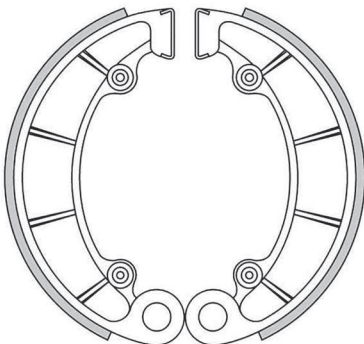

HONDA	Year	A/P
TRX 350	86->93	P
NV 400 D SHADOW SLASHER	00->02	P
TRX 500 FEC FOURTRAX 2WD-4WD	12	P
TRX 500 FMC FOURTRAX 2WD-4WD	12	P
TRX 500 FOREMAN AUTO	01->04	P
TRX 500 FOURTRAX FOREMAN 4WD FE ES	05->14	P
TRX 500 FOURTRAX FOREMAN 4X4 FM	05->14	P
TRX 500 RUBICON	00->09	P
CB 700 SC NIGHT HAWK	84->	P
VF 700 C MAGNA	85->	P
VT 700 C SHADOW	86->	P
MAGNA 750	93->	P
VFR 750 C V45 MAGNA	88->	P
VT 750 BLACK WINDOW	01->04	P
VT 750 C SHADOW	86->09	P
VT 750 SHADOW BLACK SPIRIT	10->12	P
PC 800 PACIFIC COAST	89->97	P
VT 800 C	88->	P
VT 1100 C SHADOW	87->93	P
VT 1100 C SHADOW	94->98	P
KAWASAKI	Year	A/P
VT 800 C	88->	P

GF1233 STD
øt (mm): 120 (mm): 25

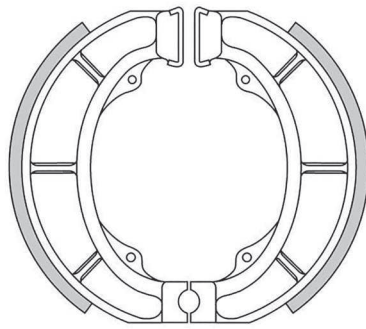

ATALA	Year	A/P
HACKER 50	96->	P
SCHEGGIA 50	98->	P
HACKER 125	98->	P

CAGIVA	Year	A/P
MANTIS 50	98->	P
PROGRESS 50	97->	P

DERBI	Year	A/P
ATLANTIS 02 50	99->	P
EASY 50	96->	P
HUNTER 50	95->	P
MANHATTAN 50	99->	P
PADDOCK 50 ST	96->	P
PREDATOR 50 0.2	99->	P
PROGRESS 50	97->	P
RECORD 50	98->	P
ST 50 PADDOCK	96->	P
VAMOS 50	94	P

HUSQVARNA	Year	A/P
WRS 50 (SCOOTER)	98->	P

ITALJET	Year	A/P
TORPEDO 50	97->	P
VELOCIFERO 50	94->	P

PGO	Year	A/P
T-REX 125 4T	95->	P
T-REX 150 4T	00->	P

PUCH	Year	A/P
LIDO 75 (scooter)	86->	A/P

RIZZATO	Year	A/P
ATALA HACKER 50	95->	P

SUZUKI	Year	A/P
ADRESS 50 (SPAIN)	92->95	A/P
AY 50 KATANA	97->	P
AY 50 W KATANA	98->	P
AY 50 WR KATANA	98->	P
CP 50	91->94	A/P
CP 50 CHF	85->	A/P
LIDO 50	89->	A/P
SEPIA 50	92->	P
ZZ 50	92->	P
LIDO 75	89->	P
AH 80	92->	P
CP 80 CHF	85->	A/P
ADDRESS 100 AH	93->95	P
AN 125	95->08	P
LIDO 125 VARIO	90->	P
AN 150	96->00	P
LT 160	89->92	A
LT 160 QUADSPORT	03->04	A
LT-F 160	90->03	A

GF1234 STD | FTR
øt (mm): 110 (mm): 28

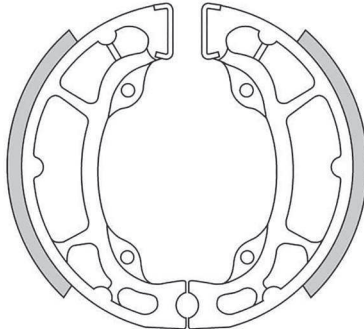

KAWASAKI	Year	A/P
KX 80	79->82	A/P

GF1235 STD
øt (mm): 110 (mm): 30

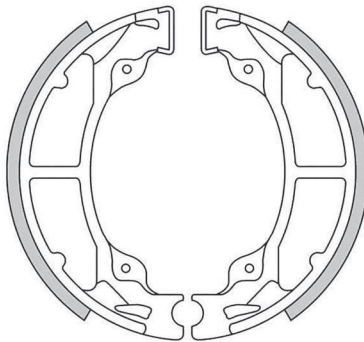

KAWASAKI	Year	A/P
KD 80	88->90	P
KH 125	77->81	P
KX 125	82->85	P
KDX 200	83->88	P

GF1236 STD
øt (mm): 120 (mm): 35

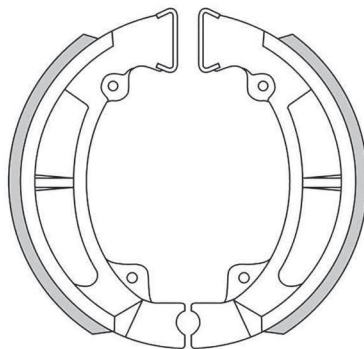

KAWASAKI	Year	A/P
KDX 200	83->85	A
KL 250	80->84	P
KLR 250 all models	84->05	P



GF1237
STD

øt (mm): 140 (mm): 28

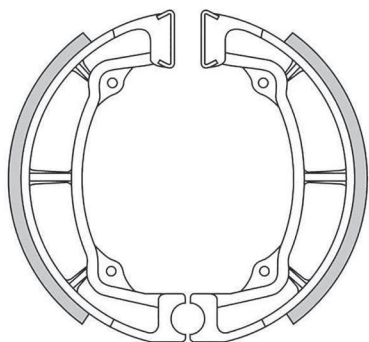

KAWASAKI	Year	A/P
KLF 185 BAYOU	86->88	A
KLT 200	81->84	P
KLT 200	83->84	P
KLF 220	88->02	A
KDX 250	79->84	A
KL 250	78->79	A
KLF 250 BAYOU	03->11	A
KLT 250 all models	83->85	P
KX 250	75->81	A
KXT 250 TECATE A1	84	A
KX 420 A1 - A2	80->81	A

GF1238
STD

øt (mm): 160 (mm): 30

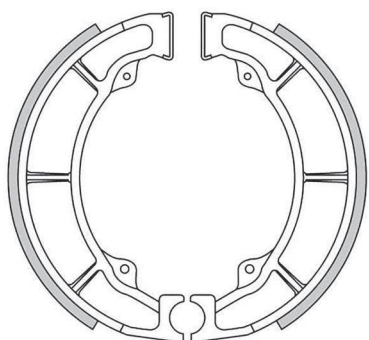

KAWASAKI	Year	A/P
KLF 185	87->	P
KLF 185 BAYOU	85->88	P
KLF 220	88->02	P
BJ 250 ESTRELLA CUSTOM	96->02	P
BJ 250 F1/F2	02->03	P
EL 250	90->03	P
EL 250 ELIMINATOR	87->89	P
ER 250 (Z 250 T SCORPION)	83->88	P
KLF 250 BAYOU	03->11	P
Z 250 B1 - B2	80->83	P
Z 250 GP BELT DRIVE	83->	P
EL 252	97->00	P
KLF 300 BAYOU	86->87	P
KLF 300 BAYOU (B1/B17)	88->04	P
GPZ 305 all models	83->96	P
Z 400 B1 - B2	78->80	P
Z 400 G1	79	P
ZR 400	83->84	P
Z 440	79->83	P
Z 440 LTD	82->84	P
ER-5 500 TWISTER	97->07	P
EX 500 all models	87->93	P
GPZ 500 S	87	P
ZR 500 A1	83->	P
Z 550 F	83->	P
ZR 550 A1	83->84	P

...GF1238

... segue KAWASAKI	Year	A/P
W 650 (EJ 650)	99->06	P
W 800 ABF (EJ 800)	11->16	P

GF1240
STD

øt (mm): 180 (mm): 40

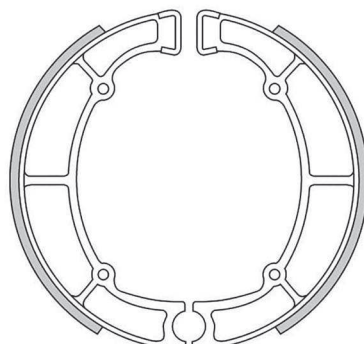

KAWASAKI	Year	A/P
VN 400 CLASSIC	99->	P
VN 400 VULCAN	95->	P
Z 400 J1 LTD	80	P
Z 400 J2 - J3	81->83	P
ZL 400	94->95	P
ZL 400 ELIMINATOR	86->87	P
ZL 400 ELIMINATOR	88	P
EN 450 LTD (454)	86->89	P
Z 450 LTD LIQUID COOLED	86->89	P
EN 500 all models	90->04	P
GT 550	83->01	P
Z 550 A1	80	P
Z 550 A3 - C1 - C2 LTD	80->	P
Z 550 G1 SHAFT	83->	P
ZL 600	85->94	P
ZL 600 ELIMINATOR	95->99	P
Z 650	77->79	P
Z 650	81->83	P
Z 650 F1	80	P
VN 700 A2-A10	86->94	P
VN 700 VULCAN	85->94	P
VN 750 TWIN	88	P
Z 750 Y1 LTD	82	P
VN 800	95->99	P
VN 800 CLASSIC	96->06	P
VN 850	95->	P

GF1241
STD

øt (mm): 110 (mm): 25

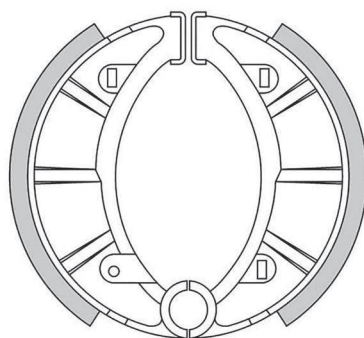

FB MINARELLI	Year	A/P
RIEJU MARATHON 50	74->	A / P
RIEJU	Year	A/P
MARATHON 50	74->	A / P

GF1242
STD

øt (mm): 180 (mm): 30

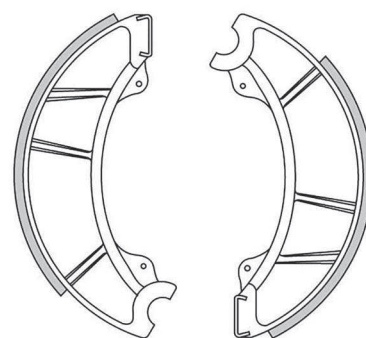

KAWASAKI	Year	A/P
S1 250 B	75->	A
Z 250 B1 - B2	80->83	A
Z 250 C1 - C2	81->	A

GF1244
STD | FTR

øt (mm): 95 (mm): 20

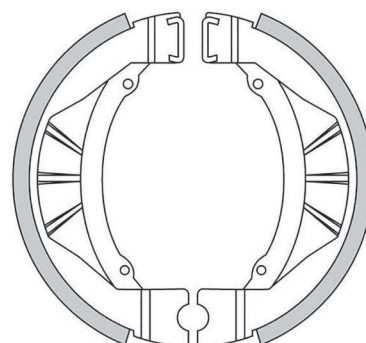

KAWASAKI	Year	A/P
KX 80	83	A

GF1245
STD

øt (mm): 90 (mm): 20

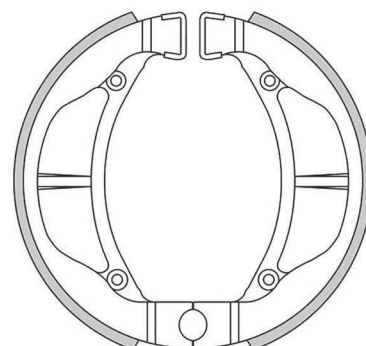

KAWASAKI	Year	A/P
KX 60	83->03	A / P
KX 80	83->87	P
KLX 110	02->20	A

SUZUKI	Year	A/P
RM 60	03	A / P
DR Z 110	03->05	A

GF1246

STD | FTR

øt (mm): 95 (mm): 20

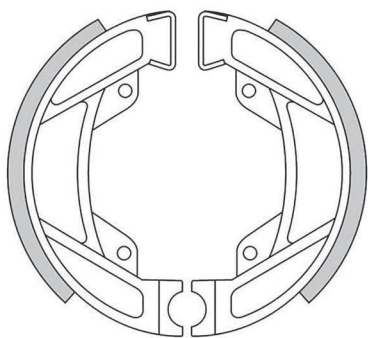

HONDA	Year	A/P
PXR 50 ALL MODELS	85->	P
MBK	Year	A/P
EVASION 50 (ruote in lega diritte)		A / P
HARDROCK 50 (ruote in lega diritte)		A / P
MAGNUM 50 (ruote in lega diritte)		A / P
PASSION 50 (ruote in lega diritte)		A / P
PEUGEOT	Year	A/P
ST 50 RAPIDO		A / P
SX 50		P
SC 80		P

GF1247

STD

øt (mm): 90 (mm): 20

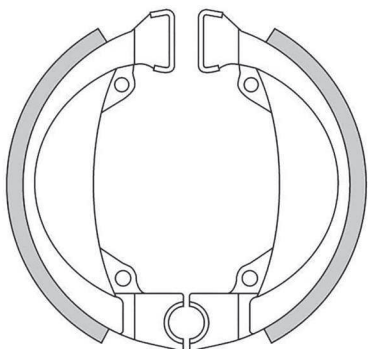

HONDA	Year	A/P
PXR 50 ALL MODELS	85->	A

GF1248

STD | FTR

øt (mm): 95 (mm): 20

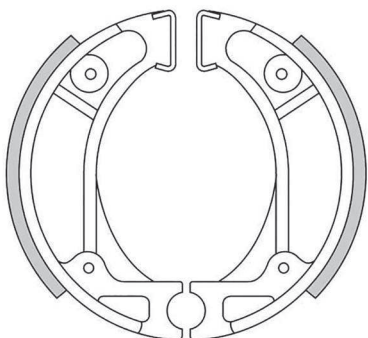

BS VILLA	Year	A/P
ZX 50	93->	P
HONDA	Year	A/P
DIO 50 GP	91->	P
DIO 50 SR	90->	P
DIO 50 ZX	92->	P

...GF1248

... segue HONDA	Year	A/P
G-DASH 50	89->	P
HSC 50 all models	92->	P
LIFE DIO 50	94->	A / P
LIFE DIO 50 ZX	94->	P
PK 50 WALLAROO DX - STD	90->	A
QR 50	93->	P
SA 50 J VISION MET-IN	88->90	A / P
SAA 50 VISION	93->	A / P
SUPER DIO 50 SR	91->92	P
SUPER DIO 50 ZX	92->	P
TLM 50 F	85->	A / P
XR 50 DIO BAJA	94->	P
CR 60 R	85->86	A / P
CRF 70	04->12	A / P
XR 70 R	97->03	A / P
SA 75 VISION	88->	P
CH 80 ELITE	85->90	P
CRF 80 F	04->14	A / P
XR 80 R	85->88	A / P
CRF 100 F	04->14	A / P
XR 100 R	93->03	A / P
CRF 110 F	13->20	A / P
CRF 125 F	14->20	P
TLR 200	83->85	A
TLR 200	83->87	P
HSC	Year	A/P
HSC 01 50	92->	P
SR 50 DIO	92->	P
ZR 50	92->	P
ZX 50 DIO	92->	P
KYMC0	Year	A/P
CX 50	94->97	P
CX 50 CURIO SUPER	94->97	P
DJW 50	94->97	P
DJX 50	91->92	P
DJY 50	93->06	P
ZK 50 SUPERFEVER	99->	P
ZX 50 FEVER	95->01	P
SYM	Year	A/P
DD 50	02->	P

GF1249

STD | FTR

øt (mm): 105 (mm): 25

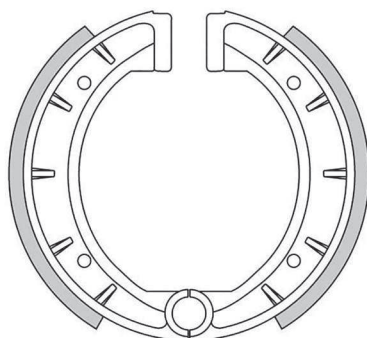

DERBI	Year	A/P
all models 50 camme 8mm	83->	A / P
all models 50 con freno a disco	83->	P

GF1251

STD

øt (mm): 140 (mm): 30

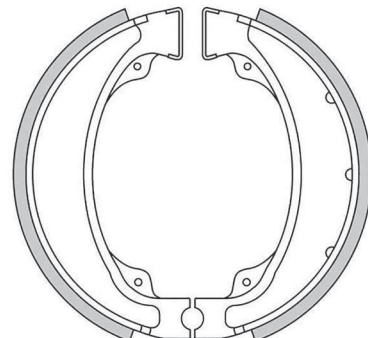

HONDA	Year	A/P
TRX 250 EX SPORTRAX	01->08	P
TRX 250 RECON	97->12	P
TRX 250 X9	09->11	P
XBR 500	85->89	P
XLV 750 R	83->88	P
KYMC0	Year	A/P
SPIKE 125	01->06	P

GF1252

STD

øt (mm): 130 (mm): 25

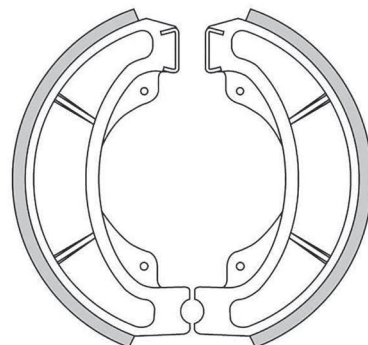

HONDA	Year	A/P
CH 250 ELITE	85->86	P
CH 250 SPACY	85->	P
CN 250 ELITE	85->86	P
CN 250 HELIX-FUSION	92->	P

GF1253

STD | FTR

øt (mm): 85 (mm): 20

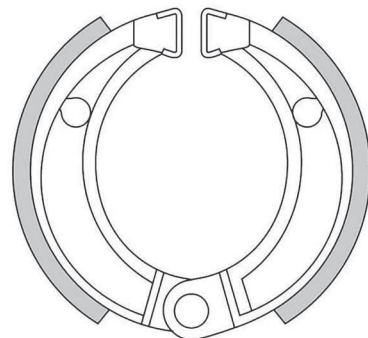

CAN AM	Year	A/P
DS 50 MINI	02->07	A
DS 70	02->07	A
DS 90 MINI 2T / 4T	02->07	A
DS 90 MINI 4T	08->20	A
QUEST 90 4T	03->	A

FIGURATO GANASCE CON APPLICAZIONI | BRAKE SHOES DRAWINGS AND APPLICATIONS | DESSINS MÂCHOIRES DE FREIN AVEC APPLICATIONS |
 DISEÑOS MORDAZAS CON RELACIÓN | ZEICHNUNGEN VON BREMSBACKEN MIT VERWENDUNGSLISTE



...GF1253		
E-TON	Year	A/P
RXL 70 VIPER	03->05	A
DXL 90 RANGER	03->04	A
RXL 90 VIPER	03->05	A
HONDA	Year	A/P
CRM 50	88->92	P
CR 80 R	85->91	P
CRM 80	88->92	P
MB 80	80->	P
KAWASAKI	Year	A/P
KXF 50	07->08	A/P
POLARIS	Year	A/P
OUTLAW 50	08->19	A
PREDATOR 50	03->07	A
SCRAMBLER 50	01->03	A
OUTLAW 90	08->14	A
PREDATOR 90	03->06	A
SCRAMBLER 90	01->12	A
SPORTSMAN 90	01->16	A
OUTLAW 110	16->19	A
SPORTSMAN 110	12->19	A

GF1254 STD

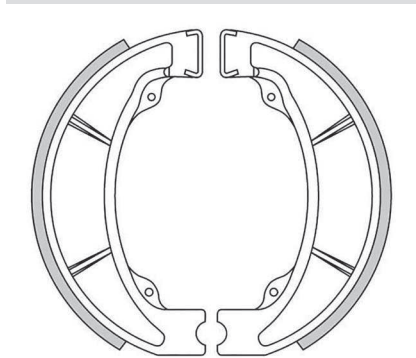

HONDA	Year	A/P
CR 125 R	86	P
CR 250 R	86	P
CR 500 R	86	P

GF1255 STD

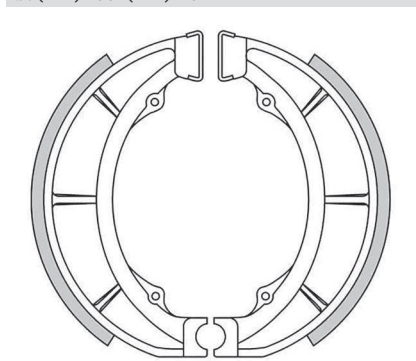

SUZUKI	Year	A/P
JR 50 all models	78->07	A/P
PE 175	80->81	P

GF1256 STD

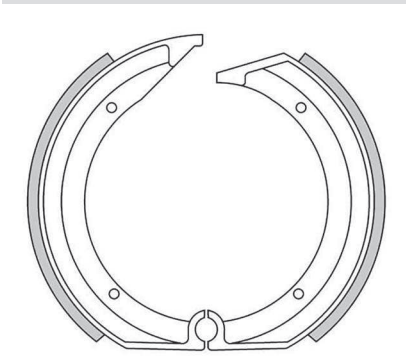

BMW	Year	A/P
K 75 750	84->88	P

GF1257 STD

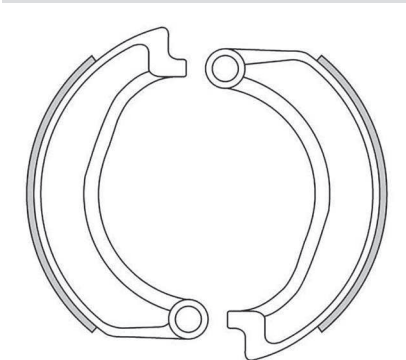

BMW	Year	A/P
R 50/5 500	69->73	A
R 60 TIC 600	78->82	A
R 60/5 600	69->73	A
R 60/6 600	73->76	A
R 75/5 750	69->75	A

GF1258 STD | FTR

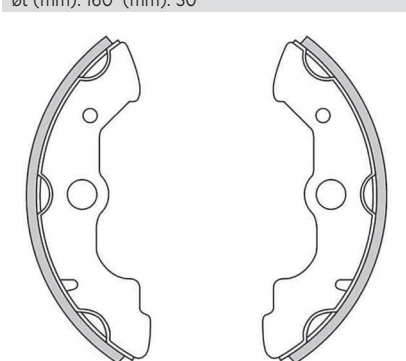

HONDA	Year	A/P
TRX 350	86->93	A

GF1259 STD

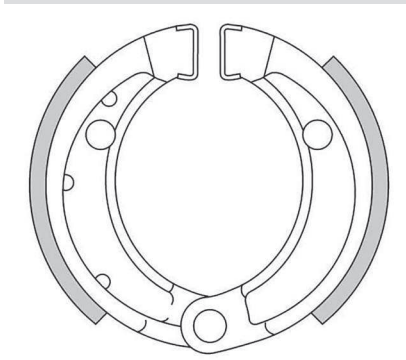

ARCTIC CAT	Year	A/P
2 WD 50	04->	A
2 WD 90	02->	A
BOMBARDIER	Year	A/P
DS 50	02->	A
QUEST 50	03->	A
DS 90	02->	A
QUEST 90	03->	A
CAN AM	Year	A/P
QUEST 50 2T	03->	A
HONDA	Year	A/P
TRX 70 FOURTRAX	86->87	A
TRX 250	86->89	P

GF1260 STD | FTR

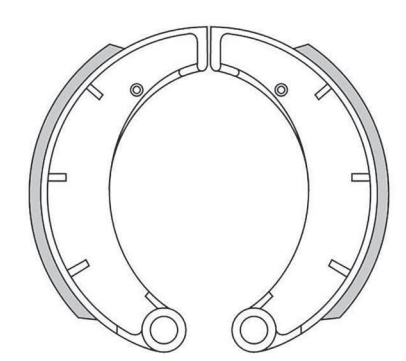

MZ	Year	A/P
ETZ 125		A
ETZ 125	->84	P
TS 125		P
ETZ 150		A
ETZ 150	->00	P
TS 150		P

GF1261 STD

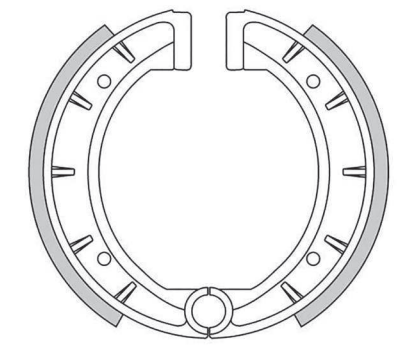

DERBI	Year	A/P
all models 50 camme 10mm	->82	A/P

GF1262

STD | FTR

øt (mm): 90 (mm): 20

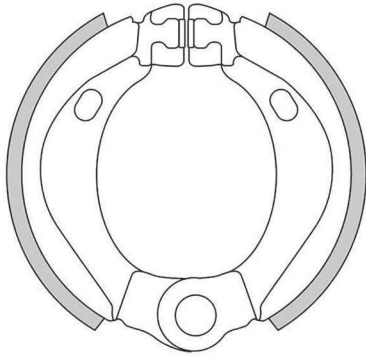

MBK	Year	A/P
EVASION 50 (ruote in lega oblique)		A / P
HARDROCK 50 (ruote in lega oblique)		A / P
MAGNUM 50 (ruote in lega oblique)		A / P
PASSION 50 (ruote in lega oblique)		A / P

GF1263

STD | FTR

øt (mm): 130 (mm): 25

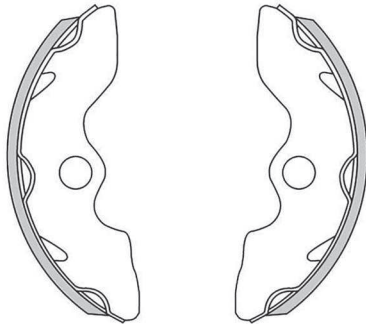

HONDA	Year	A/P
TRX 200 FOURTRAX	86->97	A
TRZ 200 (4W)	90	A
TRX 250 RECON	97->12	A
TRX 300 FOURTRAX (2WD)	88->00	A

GF1264

STD | FTR

øt (mm): 150 (mm): 25

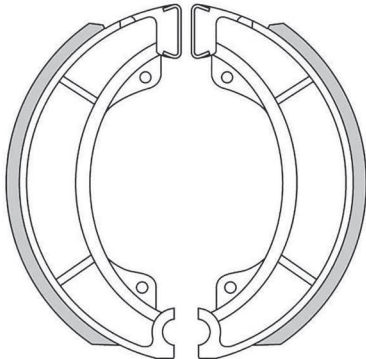

YAMAHA	Year	A/P
SR 250	87->94	A
SR 250 US CUSTOM	80->81	A

GF1265

STD

øt (mm): 130 (mm): 20

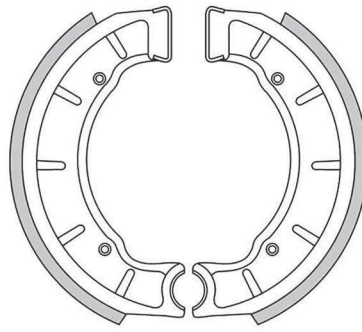

DERBI	Year	A/P
FDS 50	86->	P
TT8 75	->83	A / P
TT8 125	->83	A / P

GF1266

STD

øt (mm): 140 (mm): 30

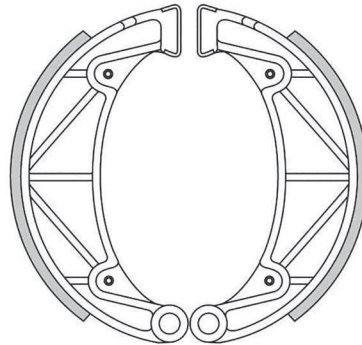

MONTESA	Year	A/P
old models 3		A

GF1267

STD

øt (mm): 130 (mm): 20

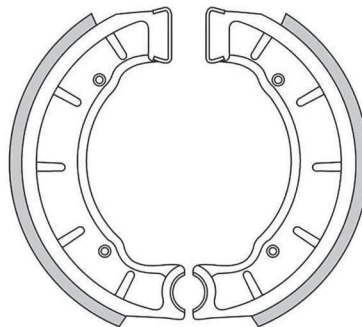

DERBI	Year	A/P
all models 50	88->	A / P

GF1268

STD

øt (mm): 165 (mm): 28

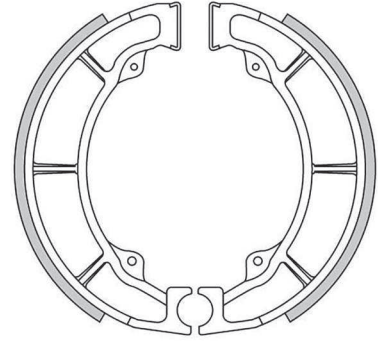

SUZUKI	Year	A/P
LT-F 250 F QUADRUNNER	99->02	P
LT-F 250 QUADRUNNER	88->01	P

GF1269

STD

øt (mm): 160 (mm): 30

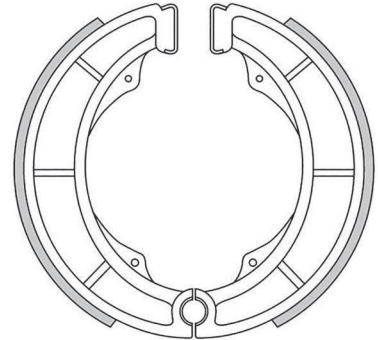

SUZUKI	Year	A/P
DR 750 S BIG	87->88	P

GF1270

STD

øt (mm): 130 (mm): 28

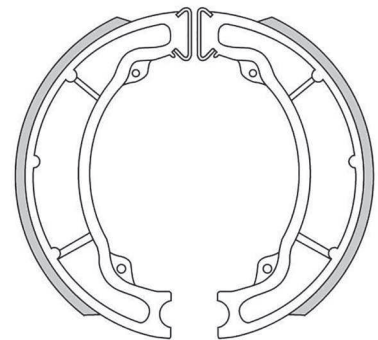

SYM	Year	A/P
HD 125	04	P

YAMAHA	Year	A/P
BELUGA 125 BL	88->92	A
BELUGA 125 XC	93->	A
RIVA 125 XX	93->	A
BELUGA 185 XC	93->	A / P



GF1271

STD

øt (mm): 80 (mm): 20

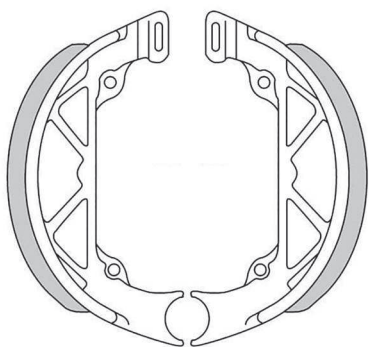
**MOBYLETTE**

Year A/P

ciclomotori 50

A

GF1272

STD

øt (mm): 100 (mm): 23

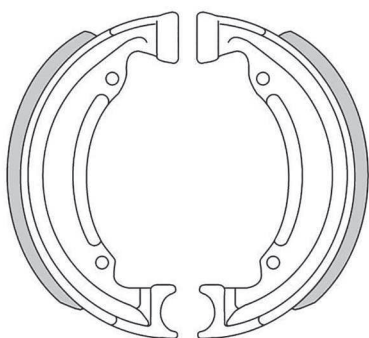
**MOBYLETTE**

Year A/P

ciclomotori 50

P

GF1273

STD

øt (mm): 160 (mm): 30

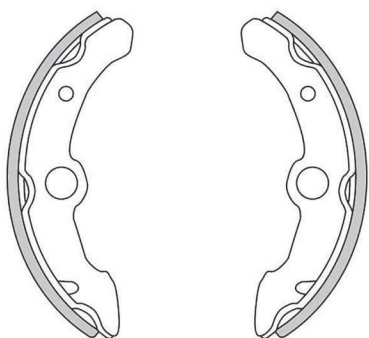
**YAMAHA**

Year A/P

YFM 350 FW BIG BEAR

87->88 A

GF1274

STD

FTR

øt (mm): 160 (mm): 30

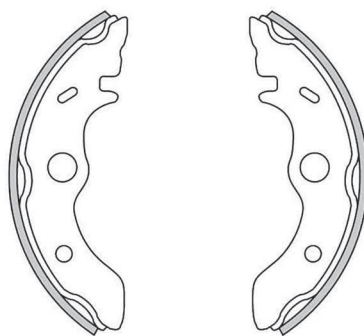
**KAWASAKI**

Year A/P

KLF 300 BAYOU

86->87 A

GF1275

STD

FTR

øt (mm): 165 (mm): 32

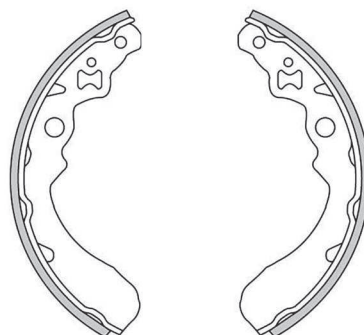
**KAWASAKI**

Year A/P

KAF 300 A1 - B1/B2 (MULE 500)

92->95 A / P

KAF 300 C1/C4 (MULE 550)

97->00 A / P

KAF 300 D1 (MULE 250)

A

SUZUKI

Year A/P

LT-F 250 4WD QUADRUNNER

97->98 A

LT-F 250 F QUADRUNNER

99->02 A

LT-F 250 QUADRUNNER

88->01 A

LT-F 300

88->89 A

GF1276

STD

FTR

øt (mm): 160 (mm): 20

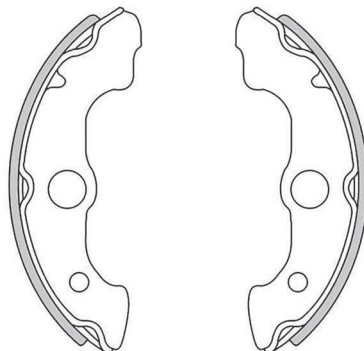
**HONDA**

Year A/P

TRX 300 FW FOURTRAX (4WD)

88->00 A

TRX 350 FOURTRAX RANCHER 4x4 FEY

00->05 A

TRX 350 FOURTRAX RANCHER 4x4 FMY

00->05 A

TRX 400 AT

04->07 A

TRX 400 FW

95->00 A

TRX 450 ES FOURTRAXFOREMAN/S

98->01 A

TRX 500 FOREMAN AUTO

01->04 A

TRX 500 RUBICON

00->09 A

TRX 650 RINCON

03-> A

GF1277

STD

øt (mm): 105 (mm): 25

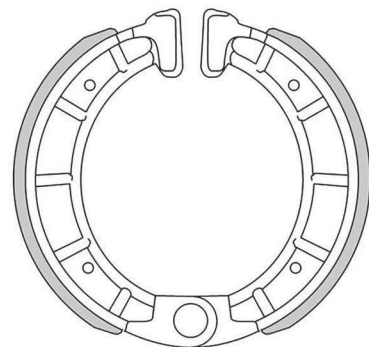
**DERBI**

Year A/P

AVENTURA 50

96-> P

BOX 50

94-> A / P

COPPA 50 FDT

86-> P

COPPA 50 FDX

87-> P

DS 50 WORLD CHAMPION

88-> P

FD 50 JUMBO

85-> P

FENIX 50

94 P

FURAX 50

96 P

FY 50 JUMBO

84-> P

SENDA 50

94-> P

URBAN 50

94-> A / P

VAMOS 50 R

95-> P

VARIANT 50 SPORT R

94-> P

TT8 75

84-> P

TT8 75 (camme 10mm)

->83 A / P

YUMBO 75 RD-2 FDS

87 P

TT8 125

84-> A / P

TT8 125 (camme 10 mm)

->83 A / P

GF1278

STD

øt (mm): 100 (mm): 20

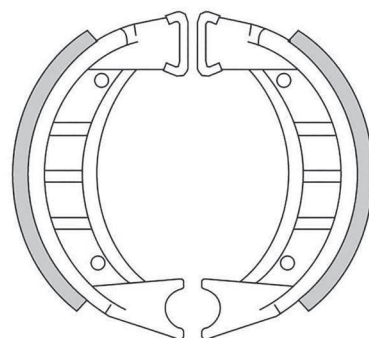
**YAMAHA**

Year A/P

YAMY 50

88-> A / P

YAMY ME 50

88-> A / P

FIGURATO GANASCE CON APPLICAZIONI | BRAKE SHOES DRAWINGS AND APPLICATIONS | DESSINS MÂCHOIRES DE FREIN AVEC APPLICATIONS |
DISEÑOS MORDAZAS CON RELACION | ZEICHNUNGEN VON BREMSBACKEN MIT VERWENDUNGSLISTE

GF1279 STD

øt (mm): 85 (mm): 20

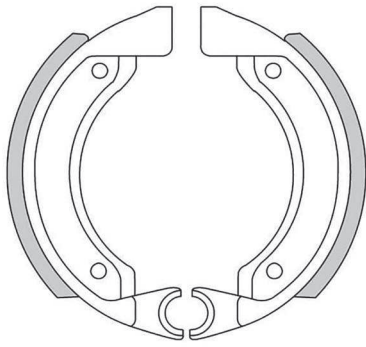

CZ - JAWA	Year	A/P
JAWA 2		A

GF1282 STD

øt (mm): 150 (mm): 30

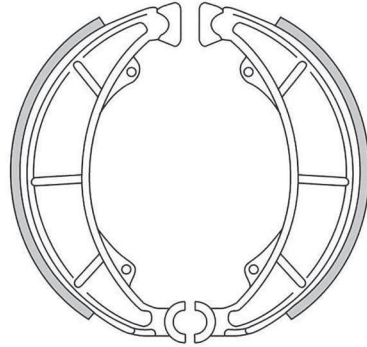

MONTESA	Year	A/P
old models 2		A

GF1285 STD

øt (mm): 150 (mm): 25

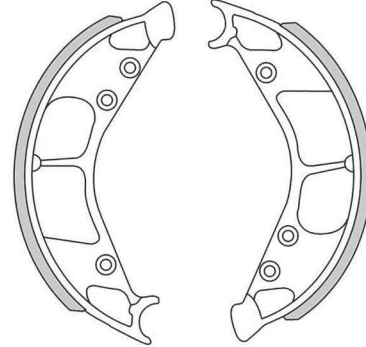

SACHS	Year	A/P
SACHS 2		P

GF1280 STD

øt (mm): 100 (mm): 18

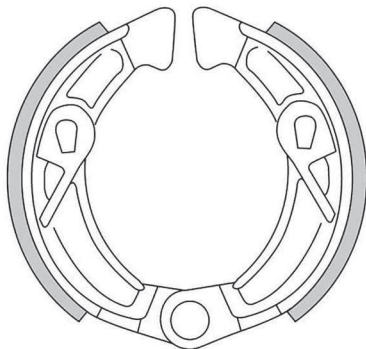

CASAL	Year	A/P
50 CICLOMOTORI		A / P

GF1283 STD

øt (mm): 120 (mm): 24

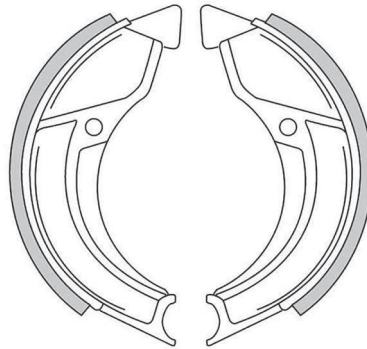

CASAL	Year	A/P
50 CICLOMOTORI (diam.110)		A / P

GF1286 STD

øt (mm): 150 (mm): 40

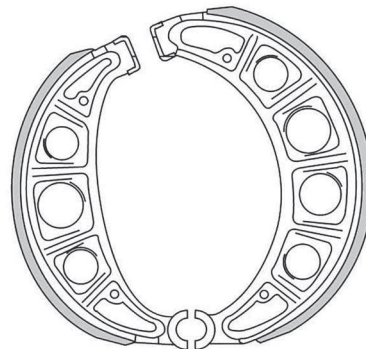

SACHS	Year	A/P
SACHS 2		A

GF1281 STD

øt (mm): 130 (mm): 30

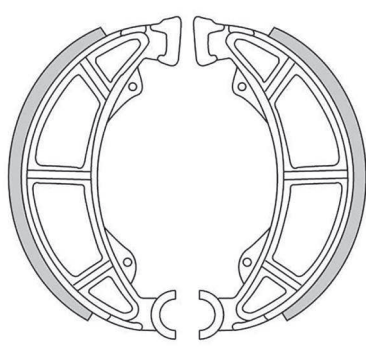

MONTESA	Year	A/P
old models 2		A / P

GF1284 STD

øt (mm): 140 (mm): 35

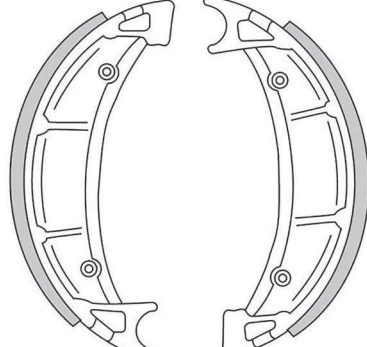

CASAL	Year	A/P
50 CICLOMOTORI (diam.140)		A / P

GF1289 STD

øt (mm): 130 (mm): 25

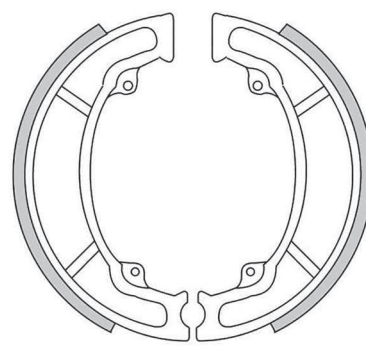

HONDA	Year	A/P
CN 250	88->92	P

ITALJET	Year	A/P
VELOCIFERO 50	94->	A

PEUGEOT	Year	A/P
ELYSEO 125	98->99	P

PIAGGIO	Year	A/P
HEXAGON 250	98->	P



GF1291

STD | FTR

øt (mm): 160 (mm): 25

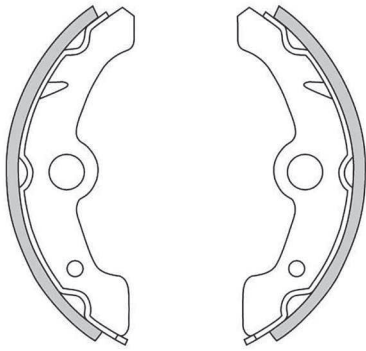

YAMAHA	Year	A/P
YFM 50 F BIG BEAR	96->98	A
YFM 350 FW	85->95	A
YFM 350 FW BIG BEAR	96->98	A
YFM 350 UH/UJ/UK	96->98	A
YFM 400 FW KODIAK	93->99	A

GF1295

STD

øt (mm): 115 (mm): 28

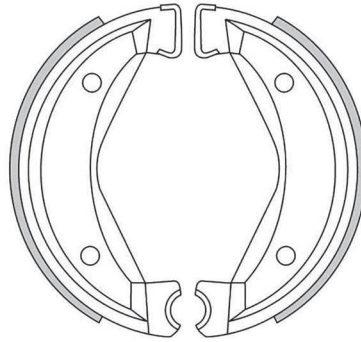

ZUNDAPP	Year	A/P
50 ZUNDAPP 3 VELOCITA		A / P

GF1299

STD

øt (mm): 120 (mm): 30

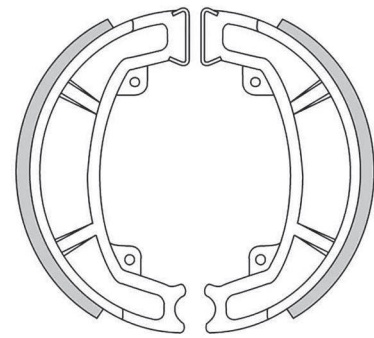

SACHS	Year	A/P
SIS / FUEGO / LOTUS 50	91->	A / P

GF1294

STD | FTR

øt (mm): 200 (mm): 27

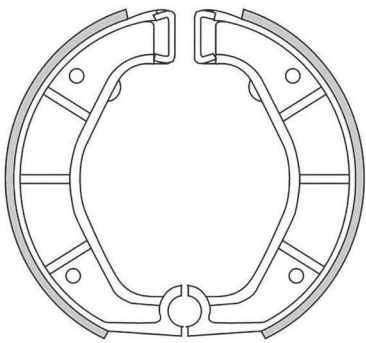

BMW	Year	A/P
R 80 GS 800	87->95	P
R 80 GS 800 PD	90->95	P
R 80 R 800 (twin disc)	88->95	P
R 80 R 800 R	91->94	P
R 80 R 800 R MYSTIK	94->95	P
R 80 RT 800 (twin disc)	88->95	P
R 850 GS	96	P
R 100 GS 1000	86->94	P
R 100 GS 1000 PD	89->96	P
R 100 R 1000	91->95	P
R 100 R 1000 MYSTIK	93->96	P
R 100 RS 1000 (21_0067 - 2478)	89->92	P
R 100 RT 1000	89->95	P

GF1296

STD

øt (mm): 110 (mm): 17

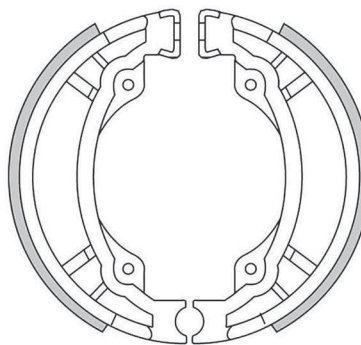

SUZUKI	Year	A/P
CARNA 50	90->	P

GF1300

STD

øt (mm): 110 (mm): 23

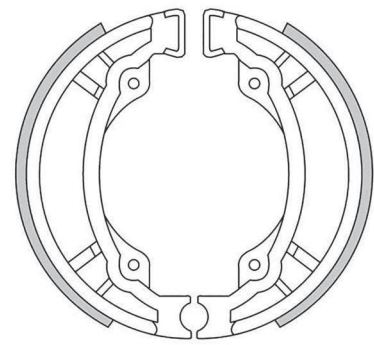

PGO	Year	A/P
BIG MAX 50	94->02	P
BIG MAX 50 CROMO		P
COMET 50	91->	P
GALAXI 50	92->	P
MEGA 50		P
PM X 50		P
PM X 50 SPORT	00->	P
PS 50	93->	P
SUPER FIFTY 50 (BRASIL)		P
T-REX 50 2T	00->	P
TORNADO 50		P
BIG MAX 90	95->	P
GALAXI 90	92->	P
T-REX 125 2T	00->	P

GF1297

STD

øt (mm): 95 (mm): 20

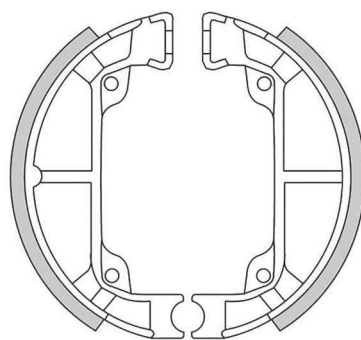

SUZUKI	Year	A/P
TR 50 STREET MAGIC	98->	P
ADRESS 100 AH	95->	P
HOKUTO 110 UG	00->	P

ATALA	Year	A/P
BYTE 50	96->	P
HACKER 50	->95	P

SUZUKI	Year	A/P
ADRESS 50	90->91	A / P
SEPIAU 50 ZZ	96->	P
TUNE 50	93->	P

SYM	Year	A/P
HUSKY 125	96->98	P
SUPER DUKE 125	95->98	P
HUSKY 150	99->	P

TGB	Year	A/P
202T 50	99->	P
203 50	02->04	P
303 R 50	99->	P
409 50	02->	P

GF1301

STD

øt (mm): 200 (mm): 35

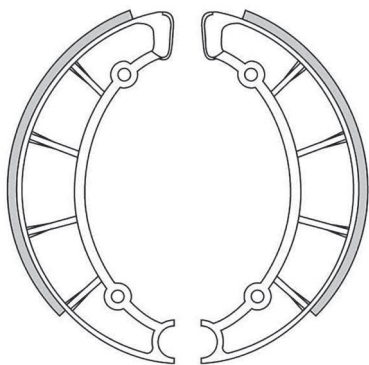

YAMAHA	Year	A/P
SR 400	88	A
SR 500	93->98	A

GF1302

STD

øt (mm): 180 (mm): 30

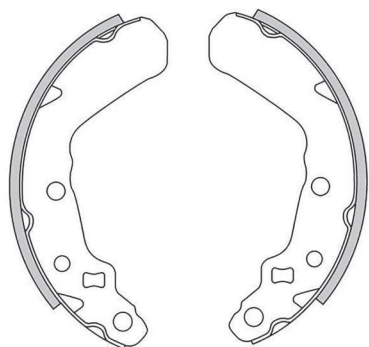

SUZUKI	Year	A/P
LT-F 300 F KING QUAD	99->01	A
LT-F 300 QUADRUNNER 4WD	91->98	A

GF1303

STD

øt (mm): 130 (mm): 28

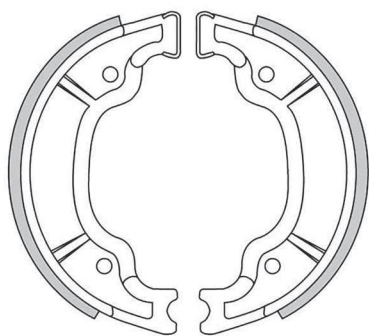

APRILIA	Year	A/P
SCARABEO 100 (motore Yamaha)	00	P

MBK	Year	A/P
DODO 50	00->	P
YW 100 BOOSTER	99->01	P
XN 125 DODO	00->01	P
YP 125 SKYLINER	98->00	P
XN 150 DODO	01->	P
YP 150 SKYLINER	00	P

YAMAHA	Year	A/P
YFM 50 RAPTOR	04->09	P
YFM 80 BADGER	92->01	P

...GF1303

... segue YAMAHA	Year	A/P
YFM 80 GRIZZLY	05->08	P
YFM 80 RAPTOR	02->08	P
AEROX 100 YQ	99->02	P
AG 100 E FARM BIKE	93	P
AG 100 J	82	P
BW S 100	99->01	P
NEOS 100 YN	99->02	P
BELUGA 125 BL	93->	P
CYGNUS R 125 XC T	95->98	A
DT 125 (3TT4)	96	A / P
MAJESTY 125 YP	98->00	P
RIVA 125 XX	93->	P
TEO'S 125 XN	99->04	P
XTZ 125	03->10	P
XVS 125 DRAGSTAR	00->04	P
XVS 125 VIRAGO	97->00	P
YBR 125	06->12	P
YBR 125 E (Brasil)	00->08	A / P
YBR 125 ED	05->12	P
YBR 125 ED (Brasil)	06->08	P
YFA 1 125 BREEZE	92->02	P
YS 125	17->19	P
FLY ONE R 150 XC	98->	P
MAJESTY 150 YP	->00	P
TEOS 150 XN	01->02	P
DT 175	97->99	A / P
MAJESTY 180 YP E	->02	P
RT 180	93->94	P
AG 200 E	93	P
SR 250	93->94	P
SR 250 CLASSIC	96->00	P
SRV 250 SOULFULTWIN RENAISSA	92->97	P
XVS 250 DRAGSTAR	01->04	P
XVS 250 VIRAGO	95->00	P
TT 350	90->95	P
XT 350	91->95	P

GF1304

STD

FTR

øt (mm): 159 (mm): 25

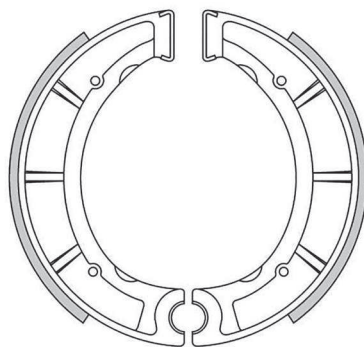

YAMAHA	Year	A/P
YFB 250 D/E/F TIMBERWOLF	92->94	P
YFB 250 FW TIMBERWOLF	94->00	A / P
YFM 250 W/A/B	90->92	A
YFM 350 ERD/ERE/ERF	92->95	A
YFP 350 TERRAPRO	88	A
YFU 350 TW/IW PRO HAULER	89->90	A
DT 400	75->77	A
DT 400 MX	75->79	A
YZ 400	77->79	P
YZ 465	80	P

GF1305

STD

øt (mm): 160 (mm): 30

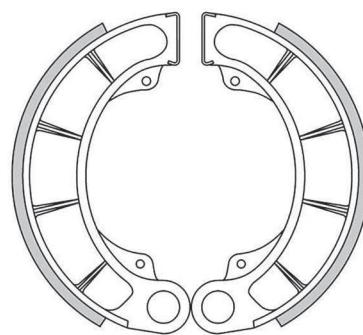

HONDA	Year	A/P
TRX 350 FOURTRAX RANCHER 4x4 FEY	00->05	P
TRX 350 FOURTRAX RANCHER 4x4 FMY	00->05	P
CB 400 SS	02	P
TRX 400 AT	04->07	P
TRX 400 FW	95->00	P
TRX 420 FOURTRAX 4WD - Power Steering FP 09->19		P
TRX 420 FOURTRAX FE ES 4WD	07->10	P
TRX 420 FOURTRAX FM 4WD AUTO	07->11	P
TRX 420 FOURTRAX TE ES 2WD	07->09	P
TRX 420 FOURTRAX TM	07->11	P
TRX 450 ES FOURTRAXFOREMAN/S	98->01	P

GF1307

STD

øt (mm): 160 (mm): 30

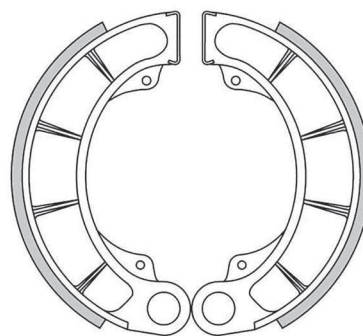

HONDA	Year	A/P
PANTHEON 125 FES	98->02	P
PANTHEON 150 FES	98->02	P
FORESIGHT 250 FES	97->98	P

GF1308

STD

øt (mm): 120 (mm): 25

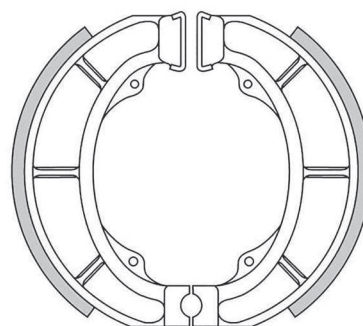

APRILIA	Year	A/P
COMPAY 50	09->13	P
HABANA 50	98->	P
MOJTO 50	99->04	P

FIGURATO GANASCE CON APPLICAZIONI | BRAKE SHOES DRAWINGS AND APPLICATIONS | DESSINS MÂCHOIRES DE FREIN AVEC APPLICATIONS | DISEÑOS MORDAZAS CON RELACIÓN | ZEICHNUNGEN VON BREMSBACKEN MIT VERWENDUNGSLISTE



GF1309 | STD

øt (mm): 130 (mm): 28

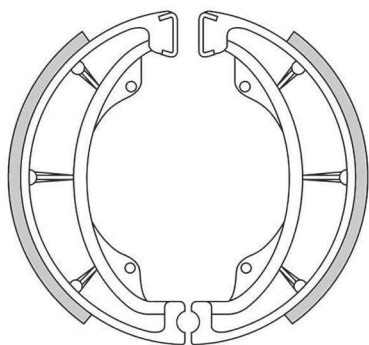

SUZUKI	Year	A/P
EPICURO 125 UC	98->00	P
EPICURO 150 UC	99->00	P

GF1311 | STD

øt (mm): 152 (mm): 30

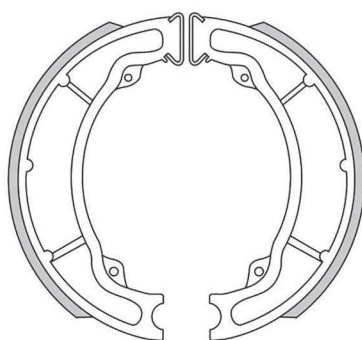

SYM	Year	A/P
HUSKY 125	99->	P

GF1314 | STD

øt (mm): 130 (mm): 25

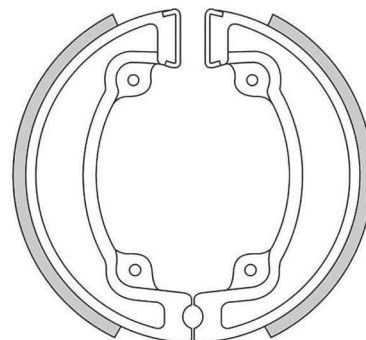

PEUGEOT	Year	A/P
ELYSEO 150	99->00	P

GF1310 | STD

øt (mm): 130 (mm): 25

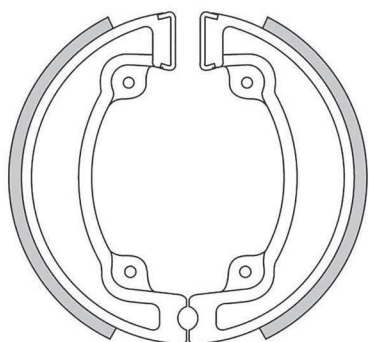

KYMCO	Year	A/P
AGILITY 50 2T PLUS	14->	P
AGILITY 50 2T R 16	10->13	P
AGILITY 50 4T PLUS	14->	P
AGILITY 50 4T R 16	08->15	P
PEOPLE 50	99->00	P
PEOPLE 50 EURO 2	03->04	P
PEOPLE S 50	05->08	P
SUPER 8 50	07	P
SUPER 8 50 2T	09->16	P
SUPER 8 50 4T	09->13	P
AGILITY 125 4T	05->08	P
AGILITY 125 RS	09	P
MOVIE 125	99->00	P
MOVIE 125 EURO 3	06->09	P
MOVIE 125 XL	01->09	P
PEOPLE 125	99->00	P
PEOPLE 125 EURO 2	03->04	P
PEOPLE ONE 125 I	13->14	P
PEOPLE S 125	05->06	P
VIVIO 125	00->03	P
XCITING 125 I	12->14	P
MOVIE 150 XL	01->04	P
PEOPLE 150	99->06	P
PEOPLE 150 EURO 3	07->08	P
VIVIO 150	01->02	P
PEOPLE S 200	05->06	P

GF1312 | STD

øt (mm): 130 (mm): 28

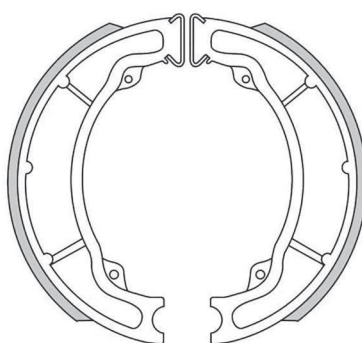

SYM	Year	A/P
RS 21 125	01	P
SUPER DUKE 150	99->02	P

GF1316 | STD | PRO

øt (mm): 125 (mm): 25

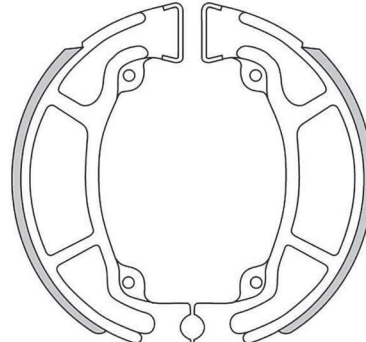

HONDA	Year	A/P
VISION 50 NSC	10->18	P
CT 110	05->09	P
VISION 110	10->19	P
@ 125 NES (tambuto post/rear drum)	00->	P
CBF 125	09->19	P
CG 125	04->10	P
CG 125	09->10	A
DYLAN 125 SES	01->07	P
PCX 125	09->20	P
PSi 125	06->13	P
SH 125 (tambuto post/rear drum)	00->08	P
@ 150 NES (tambuto post/rear drum)	00->	P
DYLAN 150 SES	01->06	P
PCX 150	09->20	P
PSi 150	06->11	P
SH 150 (tambuto post/rear drum)	00->08	P
FTR 223 Y/2/A2 (MCS4)	00->02	P
XL 230 (MC36)	02	A / P
CBF 250	04->06	P

GF1317

STD

øt (mm): 130 (mm): 28

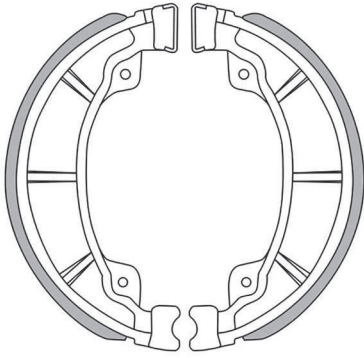

DAELIM	Year	A/P
125	00->	P

SYM	Year	A/P
SYMPHONY 50	09	P
FIDDLE II 125	09->13	P
FIDDLE III 125	14->16	P
JET 4 125	09	P
SYMPHONY 125	09	P
SYMPLY 125	07->08	P
SYMPLY II 125	09->14	P
X PRO 125	13->16	P
FIDDLE II 150	10->12	P
FIDDLE II 200	11->	P

GF1318

STD

øt (mm): 150 (mm): 28

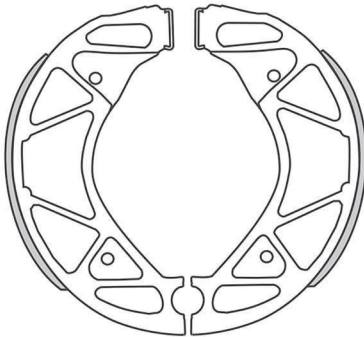

YAMAHA	Year	A/P
BWS 125 YW	10	P
CYGNUS X 125 NXC	04->11	P
XENTER 125 HW	12->16	P
XENTER 150 HW	12->18	P

FIGURATO GANASCE CON APPLICAZIONI | BRAKE SHOES DRAWINGS AND APPLICATIONS | DESSINS MÂCHOIRES DE FREIN AVEC APPLICATIONS
DISEÑOS MORDAZAS CON RELACIÓN | ZEICHNUNGEN VON BREMSBACKEN MIT VERWENDUNGSLISTE

VINTAGE

GF0029 STD
øt (mm): 142 (mm): 20

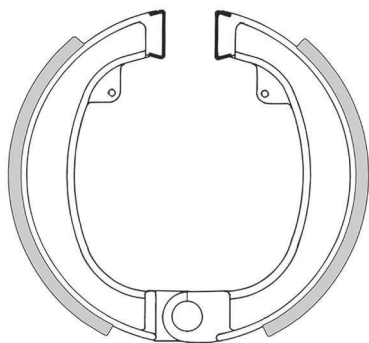

INNOCENTI

GF0205 STD
øt (mm): 128 (mm): 33

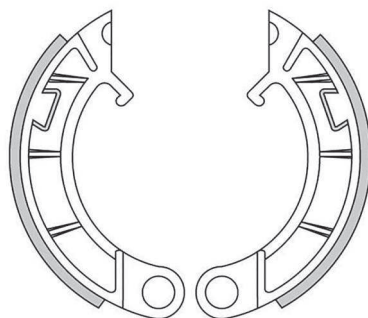

GRIMECA

GF1086 STD | FTR
øt (mm): 140 (mm): 20

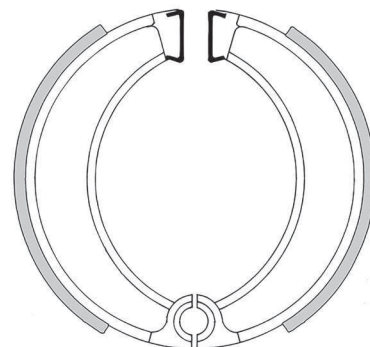

HUSQVARNA

GF0131 STD
øt (mm): 80 (mm): 20

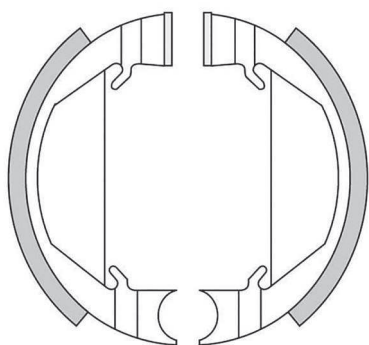

MOBYLETTE

GF0248 STD
øt (mm): 140 (mm): 25

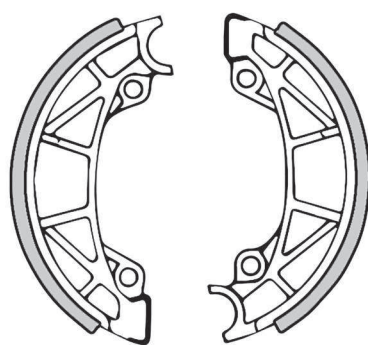

GRIMECA

GF1091 STD
øt (mm): 205 (mm): 32

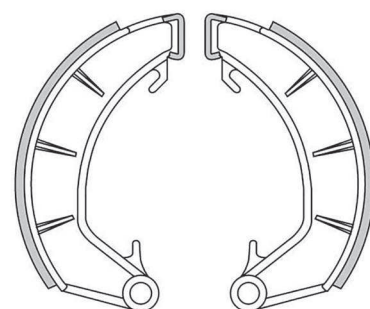

NORTON

GF0173 STD
øt (mm): 95 (mm): 20

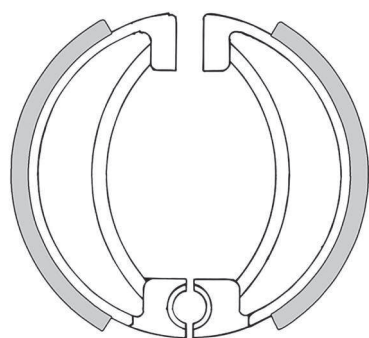

MALANCA

GF1028 STD
øt (mm): 140 (mm): 25

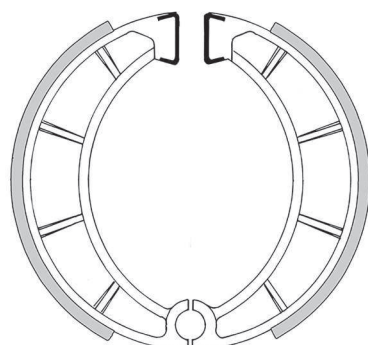

HEINKEL

GF1101 STD
øt (mm): 70 (mm): 16

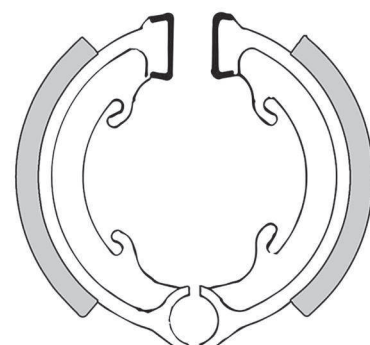

LELEU

VINTAGE

FIGURATO GANASCE CON APPLICAZIONI | BRAKE SHOES DRAWINGS AND APPLICATIONS | DESSINS MÂCHOIRES DE FREIN AVEC APPLICATIONS |
DISEÑOS MORDAZAS CON RELACIÓN | ZEICHNUNGEN VON BREMSBACKEN MIT VERWENDUNGSLISTE

GF1104

STD

øt (mm): 180 (mm): 30

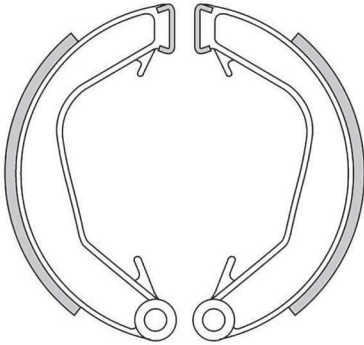

NORTON

GF1157

STD

FTR

øt (mm): 130 (mm): 28

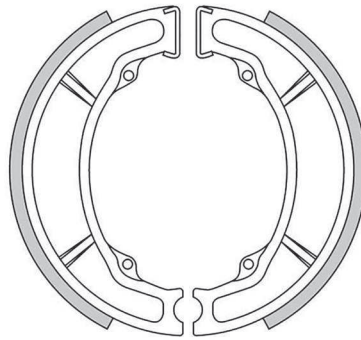

SUZUKI

GF1315

STD

øt (mm): 150 (mm): 25

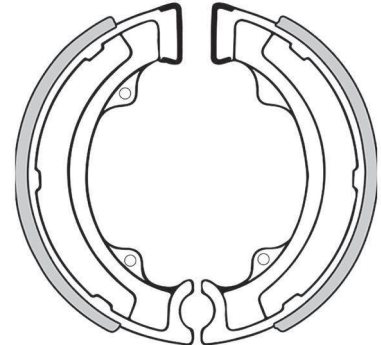

Mozzo conico inglese da 6 pollici
6" British conical hub

GF1106

STD

øt (mm): 200 (mm): 30

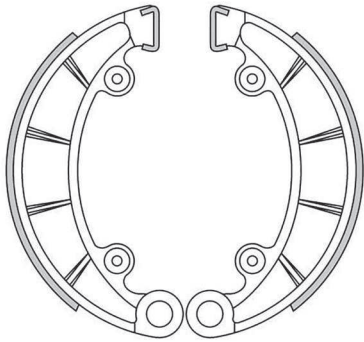

HONDA

GF1250

STD

FTR

øt (mm): 95 (mm): 22

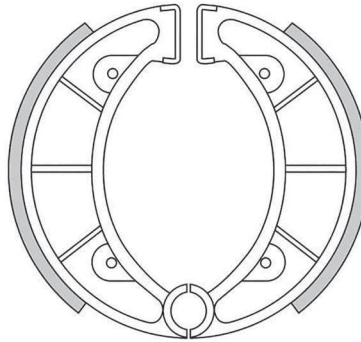

PUCH

GF1319

STD

øt (mm): 180 (mm): 25

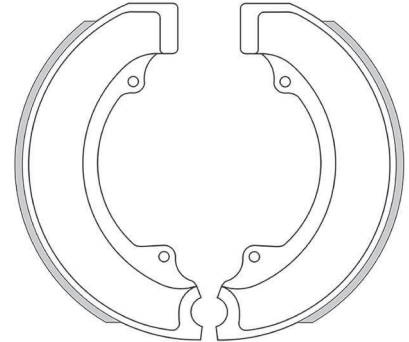

ROYAL ENFIELD

GF1111

STD

øt (mm): 200 (mm): 30

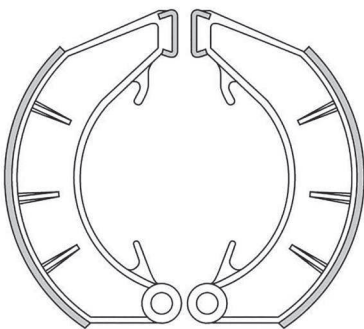

NORTON

GF1306

STD

øt (mm): 90 (mm): 18

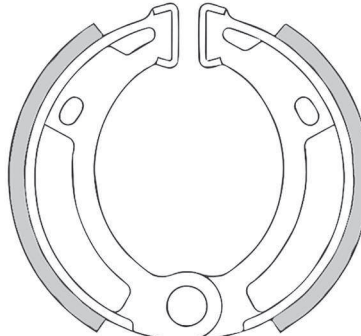

SACHS

