



EDOARDO BERTOLA - ASPAR TEAM MTR

# FIGURATO DISCHI FRENO

BRAKE DISCS DRAWINGS AND APPLICATIONS  
DESSINS DISQUES DE FREIN AVEC APPLICATIONS  
DISEÑOS DISCOS DE FRENO CON RELACIÓN  
ZEICHNUNGEN VON BREMSSCHEIBEN MIT VERWENDUNGSLISTE



**DF4001**

**A**

ØE:190 ØC:80 ØI:58 ØF:10 N°:3 SP:4

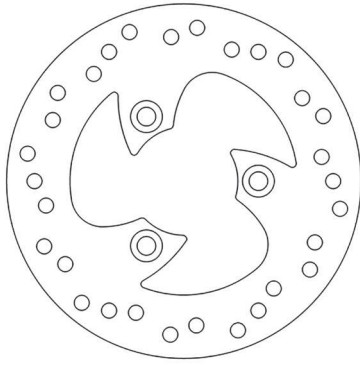

APRILIA	Year	A/P
AREA 51 50	98->	A / P
GULLIVER 50	95->98	A
HABANA 50	98->	A
MOJTO 50	99->04	A
RALLY 50	95	A
RALLY 50 liquid cooled	96->	A / P
SCARABEO 50	98->05	P
SR 50 all models	93->95	A
SR 50 H20 DITECH E (carburatore)	00->02	A / P
SR 50 H20 DITECH EURO 2	02->03	A / P
SR 50 R FACTORY (motore Piaggio)	04->05	A
SR 50 RACING	97->99	A / P
SR 50 STEALTH	97->99	A / P
SR 50 STREET	05->	A / P
SR 50 WWW	97->01	A
HABANA 125	98->	A
LEONARDO 125	95->04	P
MOJTO 125 all models	99->04	A
SR 125	99->	A
LEONARDO 150	97->04	P
MOJTO 150 all models	99->04	A
SR 150	99->	A
BETA	Year	A/P
CHRONO 50	92->94	A
CHRONO 50 ruota da 13	94->	A
QUADRA 50	95->96	A
GILERA	Year	A/P
STALKER 50 (post freno a disco)	97->04	A
STALKER 50 (post freno a tamburo)	97->04	A
STORM 50	94->95	A
TYPHOON 50	93->96	A
TYPHOON 80	93->	A
TYPHOON 125	95->98	A
HONDA	Year	A/P
BALI 50	93->	A
YUPI 90	92->	A
MALAGUTI	Year	A/P
CR1 50 CROSSER	95->98	A
F 12 50 PHANTOM	94->98	A
F 12 50 PHANTOM LC	94->98	A
F 12 50 PHANTOM LC	99->00	P
F 12 50 PHANTOM Twin disk	98	P
F 15 50 FIREFOX	96->97	P
PHANTOM MAX 100	99->	P
MBK	Year	A/P
CW 50 BOOSTER NG	99->	A
MOTRON	Year	A/P
COMPACT 50 RACING ES	89->92	A
GL 4 50 FLASH ID	89->93	A
RZ 1 50 ES	89->94	A
PEUGEOT	Year	A/P
BUXY 50	94->	A
BUXY 50 RS	94->	A
ELYSEO 50	98->01	A
SPEEDAKE 50	95->	A
SPEEDFIGHT 50 (Pinza Brembo)	96->	A
SPEEDFIGHT 50 M (Pinza Heng-Tong)	97->	A
SQUAB 50	96->	A

**...DF4001**

... segue PEUGEOT	Year	A/P
SV 50 GEO	92	A
SV 50 GEO (all models)	93->	A
SV 50 ROLLAND GARROS	93->	A
SV 50 SPORT	93->	A
SV 50 T (forcella telescopica)	93->	A
TREKKER 50	97->	A
TREKKER 50 (forcelle Paioli)	97->	A
VIVACITY 50 (forcelle Paioli)	98->07	A
SV 80 EXECUTIVE	96->	A
TREKKER 100	98->	A
VIVACITY 100	99->01	A
SV 125 GEO	91->93	A
PIAGGIO	Year	A/P
NRG 50	94->96	A
NRG 50 EXTREME	99->00	A
NRG 50 MC2	96->	A
NRG 50 MC3	01->04	A
NTT 50	->95	A
RIEJU	Year	A/P
FIRST 50 H20	97->	A

**DF4002**

**A**

ØE:200 ØC:110 ØI:98 ØF:6,4 N°:5 SP:4

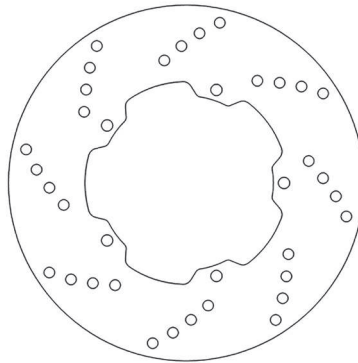

MALAGUTI	Year	A/P
CENTRO 50 SL	94->98	A
PIAGGIO	Year	A/P
QUARTZ 50	92->	A
SKIPPER 125	93->99	A
SKIPPER 150	93->99	A

**DF4004**

**A**

ØE:155 ØC:66 ØI:41 ØF:10,4 N°:3 SP:3,5

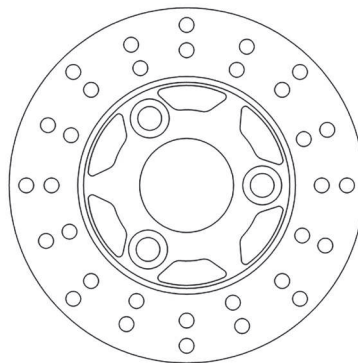

APRILIA	Year	A/P
AMICO 50 all models	92->96	A
SONIC 50 GP	97->	A
SONIC 50 SPICE	97->	A
BS VILLA	Year	A/P
AX 50	93->	A
GZ 50	93->	A
GARELLI	Year	A/P
BIG WHEEL 50	93->	A
GRINTA 50	95->	A

**...DF4004**

... segue GARELLI	Year	A/P
PONY 50 SR	92->	A
QUEENIE 50	95->	A
GILERA	Year	A/P
EASY MOVING 50	95->	A
ITALJET	Year	A/P
BAZOOKA 2 50	92->	A
PISTA 50	92->	A
SCOOP 50	93->	A
YANKEE 8 50	94->	A
MBK	Year	A/P
CR Z 50 TARGET	91->95	A
CW 50 BOOSTER	01->	A
CW 50 BOOSTER SPIRIT	96->98	A
CW 50 R BOOSTER ROAD	94->95	A
YA 50 R FORTE	94->96	A
YE 50 EVOLIS	92->95	A
YM 50 FIZZ	94->95	A
PGO	Year	A/P
BIG MAX 50	94->02	A
MEGA FIFTY 50	99->	A
BIG MAX 80	95->	A
PIAGGIO	Year	A/P
ZIP 50 FAST RIDER	93->95	A
ZIP 50 RST	96->99	A
YAMAHA	Year	A/P
AXIS 50 YA	93->	A
BREEZE 50 YM	94->96	A
BW S 50	97->	A
BW S 50 R	95->96	A
CR 50 Z	92->	A
JOG 50 (ITALIA)	91->96	A
JOG 90	90->	A

**DF4005**

**A**

ØE:175 ØC:86,5 ØI:73,3 ØF:6,5 N°:5 SP:3,5 OS:6,40

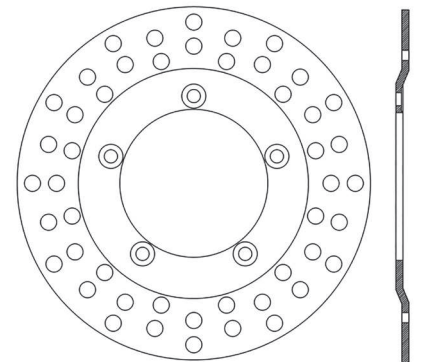

PIAGGIO	Year	A/P
HEXAGON 125	94->97	A
HEXAGON 150	94->99	A

**DF4006**

**A**

ØE:160 ØC:80 ØI:60 ØF:10,5 N°:3 SP:3,5

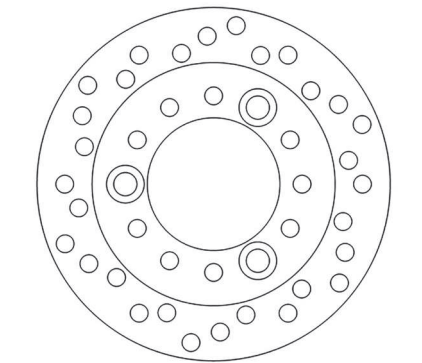

CAGIVA	Year	A/P
CITY 50	92->94	A

FIGURATO DISCHI FRENO CON APPLICAZIONI | BRAKE DISCS DRAWINGS AND APPLICATIONS | DESSINS DISQUES DE FREIN AVEC APPLICATIONS |  
DISEÑOS DISCOS DE FRENO CON RELACION | ZEICHNUNGEN VON BREMSSCHEIBEN MIT VERWENDUNGSLISTE



...DF4006		
... segue CAGIVA	Year	A/P
CITY 80	93->	A
PASSING 125	94->	A
<b>HONDA</b>	Year	A/P
DIO 50 GP	91->	A
DIO 50 SR	90->	A
DIO 50 ZX	92->	A
HSC 50 all models	92->	A
LIFE DIO 50 ZX	94->	A
SFX 50	95->	A
NH 125 LEAD	88->	A
<b>KYMCO</b>	Year	A/P
CX 50	94->97	A
CX 50 CURIO SUPER	94->97	A
HEROISM 50	95->96	A
K 12 50	95->00	A
KB 50	94->00	A
SNIPER 50 DD	94->96	A
<b>SYM</b>	Year	A/P
CINDERELLA 50	99->02	A
MIO 50	05->07	A
SUPER FANCY 50	99->00	A
CINDERELLA 100	99->00	A
ATTILA 125	95->98	A
MEGALO 125	06->07	A
NEW DUKE 125	00->01	A
SUPER DUKE 125	99->02	A
ATTILA 150	00->01	A

## DF4008 A

ØE:190 ØC:94 ØI:72 ØF:10,5 N°:4 SP:5

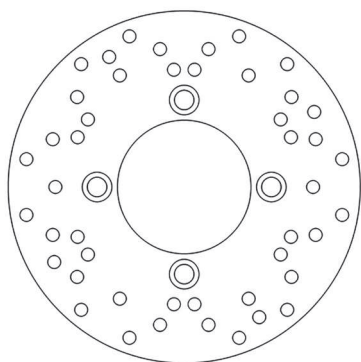

HONDA	Year	A/P
CH 250 ELITE	85->86	A
CH 250 SPACY	85->	A
CN 250	88->94	A
CN 250 ELITE	85->86	A
CN 250 HELIX	86->87	A
CN 250 HELIX-FUSION	92->	A

## DF4009 A

ØE:155 ØC:60 ØI:39 ØF:6,4 N°:5 SP:4

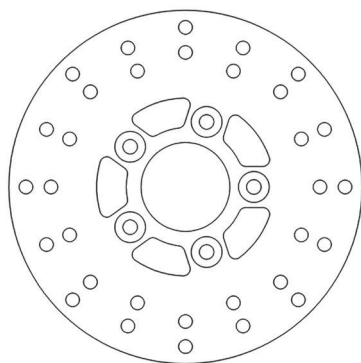

MALAGUTI	Year	A/P
F 10 50	92->98	A
F 10 50 AC	08	A

...DF4009		
... segue MALAGUTI	Year	A/P
F 10 50 RESTYLING	01->06	A
YESTERDAY 50	98->	A
<b>PEUGEOT</b>	Year	A/P
ZENITH 50	94->96	A

## DF4012 A

ØE:200 ØC:107 ØI:96 ØF:6,5 N°:5 SP:4

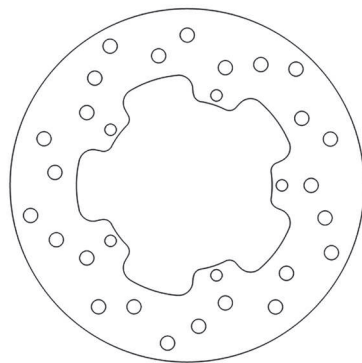

GILERA	Year	A/P
DNA 50	00->07	P
DNA 50 GP EXPERIENCE	03->04	P
DNA 125	01	P
RUNNER 125 VX / VXR 4T	01->04	P
RUNNER 180 VXR	01->04	P
RUNNER 200 FX SP	98->01	P
RUNNER 200 VX / VXR 4T	02->04	P
RUNNER 200 VXR 4T (pinza Heng Tong)	01->06	P
RUNNER 200 VXR 4T RACE	05->06	P
RUNNER 200 VXR 4T ST EURO 3	08->11	P

MALAGUTI	Year	A/P
F 12 50 PHANTOM Twin disk	98	A

PIAGGIO	Year	A/P
FLY 50 2T	05->	A
FLY 50 4T	05->10	A
FREE 50 (ruote in lega)	96->	A
SFERA 50 RST	95->	A
VESPA 50 ET2	97->	A
VESPA 50 ET2 4T	00->01	A
VESPA 50 ET2 INIEZIONE	99->	A
VESPA 50 LX 2T	05->	A
VESPA 50 LX 4T	05->	A
ZIP 50 SP	96->	A
ZIP 100 4T	06->10	A
FLY 125	05->08	A
SFERA 125 4T	95->97	A
SUPER HEXAGON 125 GTX	-> 0	A / P
VESPA 125 ET4	96->02	A
VESPA 125 LX	05->06	A
VESPA 125 LX EURO 3	06->07	A
VESPA 125 PX	98->17	A
VESPA 125 S 4T IE & COLLEGE	09->10	A
FLY 150	05->07	A
FLY 150 EURO 3	08->10	A
HEXAGON 150 LX	98->	A
VESPA 150 ET4	96->02	A
VESPA 150 LX	05->06	A
VESPA 150 LX EURO 3	06->07	A
VESPA 150 PX	98->17	A
VESPA 150 S 4T IE & COLLEGE	09->10	A
HEXAGON 180 LX	98->	A
SUPER EXAGON 180 GTX	-> 0	A / P
VESPA 200 PX	98->	A
HEXAGON 250	98->	A

## DF4013 A

ØE:175 ØC:86 ØI:73 ØF:6,4 N°:5 SP:4

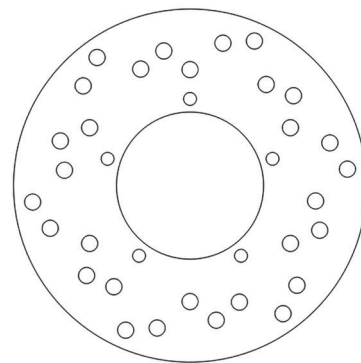

GILERA	Year	A/P
RUNNER 50 PURE JET	02->06	P
RUNNER 50 PURE JET ST	08->	P
RUNNER 50 SP	98->06	P
RUNNER 50 SP RACE	06	P
RUNNER 50 SP SC	06->07	P
RUNNER 50 SP ST	08->	P
STALKER 50 (post freno a disco)	97->04	P

PIAGGIO	Year	A/P
NRG 50 EXTREME	99->00	P
NRG 50 MC2 DD	96->98	P
NRG 50 MC3	01->04	P

## DF4014 A

ØE:220 ØC:120 ØI:105 ØF:6,4 N°:6 SP:4

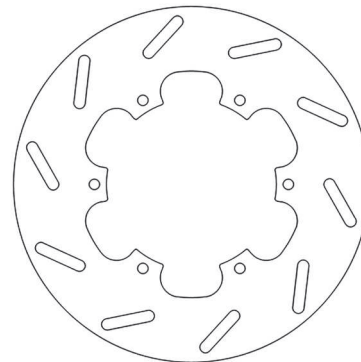

GILERA	Year	A/P
RUNNER 50 PURE JET ST	08->	A
RUNNER 50 SP ST	08->	A

PIAGGIO	Year	A/P
LIBERTY 50 2T	97->	A
LIBERTY 50 4T	00->01	A
NRG 50 MC2 DD	96->98	A
FREE 100	01->	A
LIBERTY 125	98->02	A
LIBERTY 125 4T	06->07	A
LIBERTY 125 4T EURO3	07->08	A
LIBERTY 125 4TS PORT EURO3	06->08	A
LIBERTY 125 RST	04->05	A
LIBERTY 125 RST PTT	05->11	A
LIBERTY 125 SPORT	06	A
SUPER HEXAGON 125 GTX	01->02	P
VESPA 125 GRANTURISMO	06->07	A / P
VESPA 125 GRANTURISMO L (pinza Grimeca)	03->05	A / P
VESPA 125 GRANTURISMO L (pinza HengTong)	03->05	A / P
VESPA 125 GTS 4T IE SUPER	09->16	A / P
VESPA 125 GTS EURO 3	07->12	A / P
VESPA 125 GTV	06->08	A / P
VESPA 125 GTV 4T NAVY EURO 3	08	A / P
LIBERTY 150 4T	08	A
LIBERTY 150 4T SPORT	08	A
LIBERTY 150 LE	00->02	A

...DF4014		
... segue PIAGGIO	Year	A/P
SUPER EXAGON 180 GTX	01->04	P
LIBERTY 200	06	A
LIBERTY 200 4T EURO3	07->08	A
LIBERTY 200 4T SPORT EURO 3	06->07	A
LIBERTY 200 RST	04->05	A
LIBERTY 200 SPORT	06	A
VESPA 200 GRANTURISMO (pinza Grimeca)	06->	A/P
VESPA 200 GRANTURISMO (pinza Heng Tong)	06->	A/P
VESPA 200 GRANTURISMO L (pinza Grimeca)	03->05	A/P
VESPA 200 GRANTURISMO L (pinza Heng Tong)	03->05	A/P
VESPA 250 GTS (pinza Grimeca)	05->	A/P
VESPA 250 GTS (pinza Heng Tong)	05->	A/P
VESPA 250 GTV	06->	A/P

DF4015		
ØE:220	ØC:80	ØI:60
ØF:6,5	N°:5	SP:4

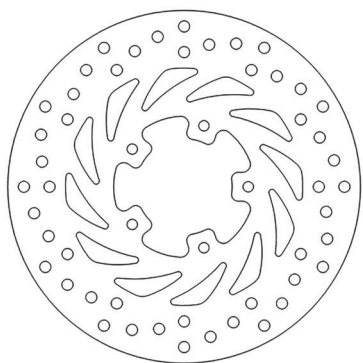

GILERA		
Year	A/P	
RUNNER 50	96->	A
RUNNER 50 PURE JET	02->06	A
RUNNER 50 SP	98->06	A
RUNNER 50 SP RACE	06	A
RUNNER 50 SP SC	06->07	A
RUNNER 125	97->99	A
RUNNER 125 FX - FXR	97->02	A
RUNNER 125 SP	99->	A
RUNNER 125 VX / VXR 4T	01->04	A
RUNNER 180	97->98	A
RUNNER 180 FXR	98->	A
RUNNER 180 SP	99->	A
RUNNER 180 VXR	01->04	A
RUNNER 200 FX SP	98->01	A
RUNNER 200 VX / VXR 4T	02->04	A
RUNNER 200 VXR 4T (pinza Heng Tong)	01->06	A
RUNNER 200 VXR 4T RACE	05->06	A
RUNNER 200 VXR 4T ST EURO 3	08->11	A

DF4016		
ØE:160	ØC:76	ØI:60,3
ØF:6,6	N°:4	SP:4

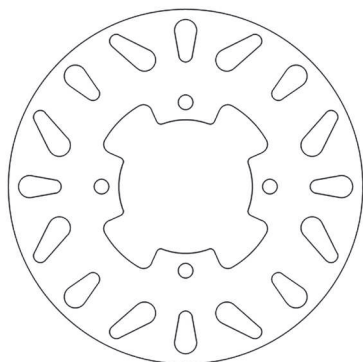

KYMCO		
Year	A/P	
SNIPER 50 DD	94->96	P

DF4017		
ØE:220	ØC:80	ØI:60
ØF:8,5	N°:5	SP:4

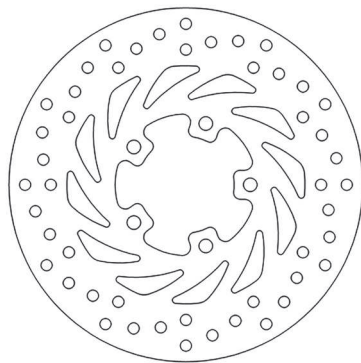

APRILIA		
Year	A/P	
LEONARDO 125	95->04	A
SCARABEO 125 (motore Rotax)	99->03	P
SPORT CITY 125	04->05	P
SPORT CITY 125 CUBE	08->10	P
SPORT CITY 125 EU3	06->08	P
LEONARDO 150	97->04	A
SCARABEO 150	98->03	P
SCARABEO 150 GT	04->	P
SCARABEO 200	01->03	P
SCARABEO 200 GT	02->	P
SPORT CITY 200	04->05	P
SPORT CITY 200 CUBE	09->	P
SPORT CITY 200 EU3	06->08	P
LEONARDO 250	99->01	A
LEONARDO 250 ST	01->04	A
SPORT CITY 250 CUBE	08->10	P
SPORT CITY 250 EU3	06->	P
LEONARDO 300	02->04	A

DF4018		
ØE:220	ØC:80	ØI:60
ØF:6,4	N°:5	SP:4

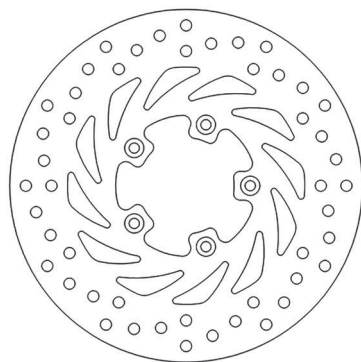

APRILIA		
Year	A/P	
SCARABEO 50	98->05	A
SCARABEO 50 4T	02->06	A
SCARABEO 50 4T RESTYLING	06->07	A
SCARABEO 50 DITECH	01->04	A
SCARABEO 50 STREET	02->06	A
SCARABEO 50 STREET RESTYLING	06->07	A
SCARABEO 100 (motore Yamaha)	00	A
SCARABEO 100 4T	01->04	A
SCARABEO 100 4T RESTYLING	06->12	A
SCARABEO 100 NET	10->	A

DF4021		
ØE:180	ØC:66	ØI:48
ØF:10,4	N°:4	SP:3,5

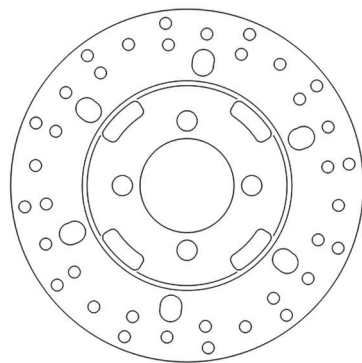

MBK		
Year	A/P	
CW 50 BOOSTER SPIRIT	99->	A
CW 50 L BOOSTER	01->	A
CW 50 RS BOOSTER NG	95->98	A
CW 50 RSP BOOSTER ROCKET	97->98	A
CW 50 RSX TRACK	96->98	A

DF4022		
ØE:260	ØC:142	ØI:121,2
ØF:10,3	N°:6	SP:4

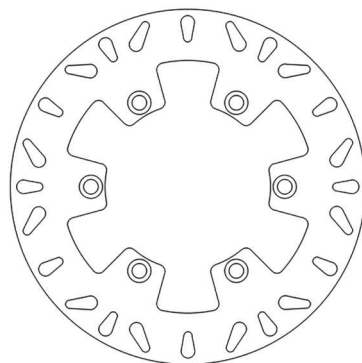

SUZUKI		
Year	A/P	
BURGMAN 250 AN	96->02	A
BURGMAN 400 AN	98->02	A

DF4023		
ØE:245	ØC:133	ØI:115
ØF:8,5	N°:6	SP:4

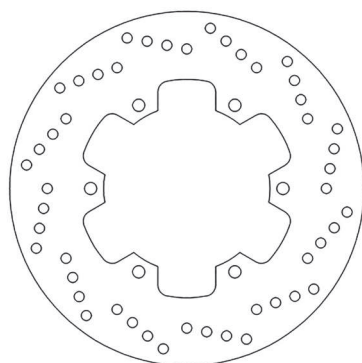

DUCATI		
Year	A/P	
MONSTER 400	95->08	P
MONSTER 400 DARK IE	05	P
SUPERSPORT 400	93->97	P
MONSTER 600	93->01	P
MONSTER 600 CITY - CITY DARK - DARK	99	P
MONSTER 600 DARK	98	P
SUPERSPORT 600	91->97	P
MONSTER 620	05->06	P
MONSTER 620 (5 marce - single disk)	04	P



...DF4023		
... segue DUCATI	Year	A/P
MONSTER 620 (6 marce)	04	P
MONSTER 620 DARK	05->06	P
MONSTER 620 DARK (single disk)	05	P
MONSTER 620 IE	02->04	P
MULTISTRADA 620	06	P
MULTISTRADA 620 DARK (single disk)	06	P
SPORT 620	03->04	P
SUPERSPORT 620	03->04	P
MONSTER 695	07->08	P
MONSTER 696 (700cc)	08->14	P
MONSTER 750	96->01	P
MONSTER 750 CITY - CITY DARK	99	P
MONSTER 750 IE	02	P
SPORT 750	00->02	P
SUPERSPORT 750	91->02	P
SUPERSPORT 750 IE	00->02	P
MONSTER 800	03->04	P
SPORT 800	03->06	P
SUPERSPORT 800	03->06	P
851 all models	91->92	P
888 all models	93->95	P
888 DESMOQUATTRO	93->94	P
888 SUPERBIKE STRADA	94->95	P
MONSTER 900	93->99	P
MONSTER 900 IE	00->02	P
SPORT 900	02	P
SUPERSPORT 900	98->99	P
SUPERSPORT 900 F.E.	98	P
SUPERSPORT 900 IE	00->02	P
SUPERSPORT 900 SUPERLIGHT	91->97	P
MONSTER 916 S4	01->02	P
MONSTER 916 S4 FOGGY	02	P
ST4 916	99->03	P
ST2 944	97->03	P
ST4S 996	01->05	P
ST4S 996 ABS	03->05	P
GT 1000	07->10	P
GT 1000 TOURING	09	P
MONSTER 1000	03->05	P
MONSTER 1000 S	05	P
PAUL SMART 1000 L.E.	06	P
SPORT 1000	06->08	P
SPORT 1000 S	07->09	P
ST3 1000	04->07	P
SUPERSPORT 1000	03->06	P
ITALJET	Year	A/P
JUPITER 250	00->	P
LAVERDA	Year	A/P
SPORT 650	95->01	P
DIAMANTE 668	96->98	P
GHOST 668	96->99	P
STRIKE 668	97->99	P
BLACK STRIKE 750	00->	P
FORMULA 750	97->01	P
SPORT 750	97->98	P
STRIKE 750	98->01	P
SUPER SPORT 750	99->00	P
T-8 800	98	P
TTS 800	98	P
MBK	Year	A/P
YP 250 SKYLINER	00->03	A
MOTOR UNION	Year	A/P
MAXI 125	99->	A
MAXI 150	99->	A
MAXI 400	99->	A
YAMAHA	Year	A/P
TEOS 150 XN	01->02	A
MAJESTY 250 YP	96->03	A
MAJESTY 250 YP ABS	03->	A
MAJESTY DX 250 YP	98->99	A

## DF4024 A

ØE:210 ØC:132 ØI:109 ØF:10,6 N°:5 SP:5

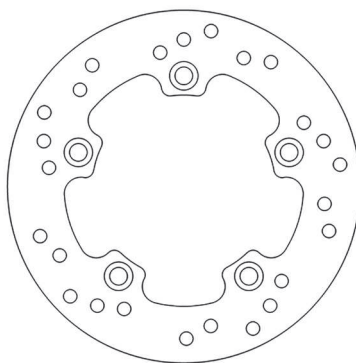

SUZUKI	Year	A/P
BURGMAN 250 AN	96->02	P
BURGMAN 400 AN	98->02	P

## DF4025 A

ØE:180 ØC:80 ØI:58 ØF:10,5 N°:3 SP:4

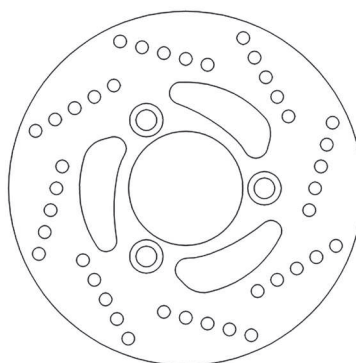

KYMCO	Year	A/P
AGILITY 50	05->08	A
AGILITY 50 4T R 12	07->15	A
DINK 50 LC	98->02	A
SUPER 9 50	00->01	P
SUPER 9 50 SPORT EURO 2	03->04	P
TOP BOY 50 ON / OFF ROAD	96->05	A
VITALITY 50 4T	04->09	A
AGILITY 125 4T	05->08	A
DINK 125	96->99	A / P
DINK 150 CLASSIC	02	P
DINK 150 LX	98->00	A / P

## DF4026 A

ØE:220 ØC:76 ØI:54 ØF:8,5 N°:4 SP:4,5

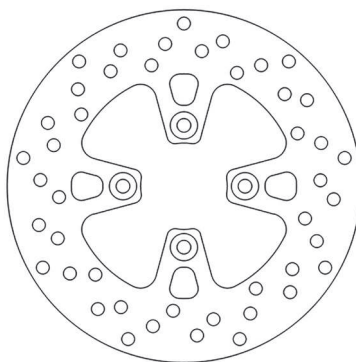

MBK	Year	A/P
XN 125 DOODO	00->01	A
YP 125 SKYLINER	98->00	A
XN 150 DOODO	01->	A

## ...DF4026

... segue MBK	Year	A/P
YP 150 SKYLINER	00->02	A
YP E 180 SKYLINER	03	A
YAMAHA	Year	A/P
MAJESTY 125 YP	98->00	A
MAJESTY 125 YP E	01->09	A
TEO'S 125 XN	99->04	A
MAJESTY 150 YP	-> 2	A
MAJESTY 180 YP E	-> 6	A

## DF4028 A

ØE:174 ØC:60 ØI:38 ØF:6,5 N°:5 SP:4

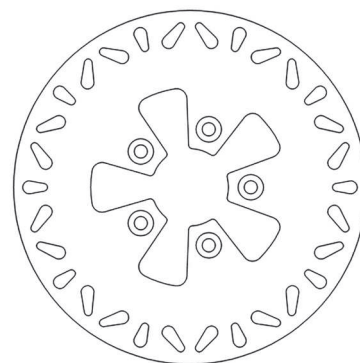

ITALJET	Year	A/P
DRAGSTER 50	97->	A
FORMULA 50	94->97	A
DRAGSTER 125	97->03	A
FORMULA 125	94->97	A
DRAGSTER 180	97->	A

## DF4029 A

ØE:240 ØC:101 ØI:90 ØF:6,5 N°:6 SP:4

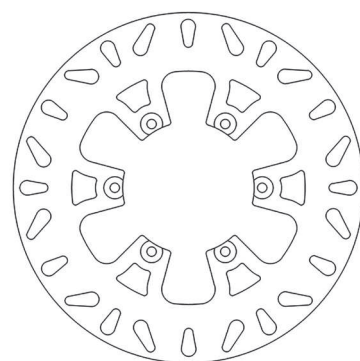

MALAGUTI	Year	A/P
MADISON S 250	99->01	A
MADISON K 400	02	P
MADISON K 400 RESTYLING	02->04	P

**DF4030**

**A**

ØE:230 ØC:120 ØI:105 ØF:6,2 N°:6 SP:4

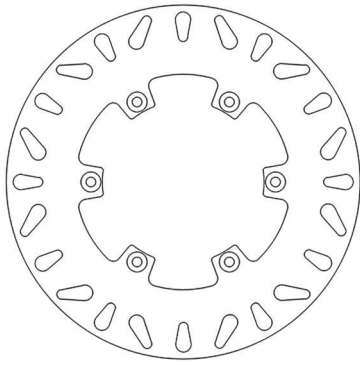

**DF4032**

**A**

ØE:220 ØC:101,5 ØI:90 ØF:6,3 N°:6 SP:4

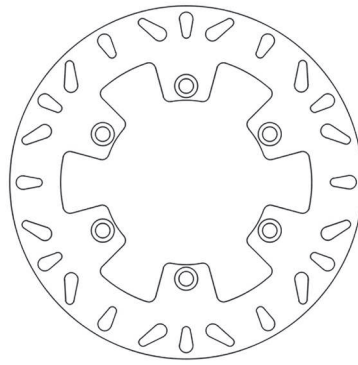

**DF4035**

**A**

ØE:220 ØC:120 ØI:102 ØF:8,6 N°:5 SP:4

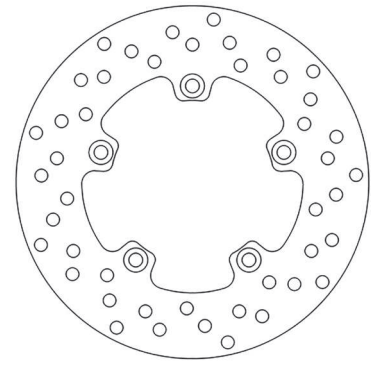

MALAGUTI	Year	A/P
CIAK 50	99->00	A
CIAK 50 MASTER	04->05	A
CIAK 50 MASTER 4T	05->06	A
CIAK 50 MASTER EURO 2	06	A
CIAK 50 MONO EURO 2,3	03	A
CIAK 50 TD	00->01	A
CIAK 50 TWIN DISK	02->	A
CIAK 100	99->01	A
CIAK 125	00->01	A
CIAK 125 MASTER	04	A
CIAK 125 MASTER EURO 3	06	A
CIAK 125 RESTYLING	03	A
CIAK 150	00->02	A
CIAK 150 MASTER	03	A
CIAK 150 RESTYLING EURO 2	04	A
CIAK 200 MASTER EURO 2	06	A

BENELLI	Year	A/P
VELVET 125	99->04	P
VELVET 125 TOURING	02->03	P
VELVET 150	99->04	P
VELVET 150 TOURING	02->03	P
VELVET 250	99->	P
VELVET 250 TOURING	01->	P
VELVET 400 DUSK	03->	P

MALAGUTI	Year	A/P
MADISON 125	99->02	P
PHANTOM MAX 125	03->	P
MADISON T 150	99->01	P
MADISON R 180	01->02	P
MADISON 200	99->01	P
MADISON S 200 RESTYLING	02->03	P
PHANTOM MAX 200	03	P
MADISON RS 250 RESTYLING	04	P
MADISON S 250	99->01	P
PHANTOM MAX 250	04	P

APRILIA	Year	A/P
RS 50	99->05	P
RS 50 REPLICA	00->05	P
TUONO 50	03->04	P
RS 125	96->11	P
SCARABEO 125 IE LIGHT	08->10	P
SCARABEO 125 LIGHT	07->08	P
TUONO 125	03->07	P
SCARABEO 200	07->	P
SCARABEO 200 CLASS	10->	P
SCARABEO 200 IE LIGHT	12->	P
SCARABEO 250 LIGHT	06->08	P

BMW	Year	A/P
C 1 125	99->	A / P
C 1 200	01->	A / P

MBK	Year	A/P
XQ 125 THUNDER	01->	P

YAMAHA	Year	A/P
MAXSTER 125 XQ	01->05	P
MAXSTER 150 XQ	01->02	P

**DF4031**

**A**

ØE:220 ØC:101,5 ØI:90 ØF:6,3 N°:6 SP:4

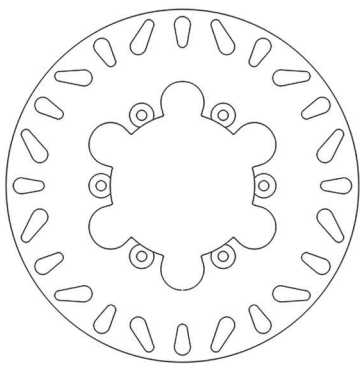

MALAGUTI	Year	A/P
MADISON 125	99->02	A
PHANTOM MAX 125	03->	A
MADISON T 150	99->01	A
MADISON R 180	01->02	A
MADISON 200	99->01	A
MADISON S 200 RESTYLING	02->03	A
PHANTOM MAX 200	03	A
MADISON RS 250 RESTYLING	04	A
PHANTOM MAX 250	04	A

**DF4033**

**A**

ØE:200 ØC:80 ØI:58 ØF:9 N°:3 SP:4

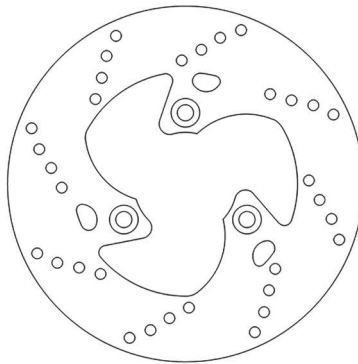

MALAGUTI	Year	A/P
F 12 50 PHANTOM LC	99->00	A
F 15 50 FIREFOX	96->97	A
PHANTOM MAX 100	99->	A
F 18 125 WARRIOR	00->02	P
F 18 150 WARRIOR	00->02	P

PEUGEOT	Year	A/P
DJANGO 50 HERITAGE	14->	A
VIVACITY 50 4T	08->	A
VIVACITY 50 SIXTIES	11->	A

**DF4038**

**A**

ØE:260 ØC:79,9 ØI:60 ØF:8,5 N°:5 SP:4

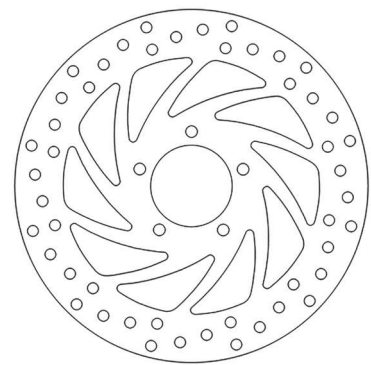

APRILIA	Year	A/P
SCARABEO 125	04->06	A
SCARABEO 125 (motore Piaggio)	03	A
SCARABEO 125 (motore Rotax)	99->03	A
SCARABEO 125 EU3	06->07	A
SCARABEO 125 GT	99->03	A
SCARABEO 125 IE LIGHT	08->10	A
SCARABEO 125 LIGHT	07->08	A
SPORT CITY 125	04->05	A
SPORT CITY 125 CUBE	08->10	A
SPORT CITY 125 EU3	06->08	A
SCARABEO 150	98->03	A
SCARABEO 150 GT	04->	A
SCARABEO 200	01->03	A
SCARABEO 200 (motore Piaggio)	03->	A
SCARABEO 200 CLASS	10->	A
SCARABEO 200 GT	02->	A
SCARABEO 200 IE LIGHT	12->	A
SPORT CITY 200	04->05	A

FIGURATO DISCHI FRENO CON APPLICAZIONI | BRAKE DISCS DRAWINGS AND APPLICATIONS | DESSINS DISQUES DE FREIN AVEC APPLICATIONS  
DISEÑOS DISCOS DE FRENO CON RELACION | ZEICHNUNGEN VON BREMSSCHEIBEN MIT VERWENDUNGSLISTE



...DF4038		
... segue APRILIA	Year	A/P
SPORT CITY 200 CUBE	09->	A
SPORT CITY 200 EU3	06->08	A
SCARABEO 250	04->06	A
SCARABEO 250 IE	06->09	A
SCARABEO 250 LIGHT	06->08	A
SPORT CITY 250 CUBE	08->10	A
SPORT CITY 250 EU3	06->	A
SCARABEO 300 LIGHT	06->10	A
SCARABEO 300 SPECIAL IE	09->	A
SPORT CITY 300 CUBE	08->	A
ATLANTIC 400 SPRINT	05->08	A
SCARABEO 400 LIGHT	06->08	A
SCARABEO 400 URBAN	06->08	A
ARECIFE 500 (spagna)	02->04	A
ATLANTIC 500	02->04	A
ATLANTIC 500 SPRINT	05->08	A
SCARABEO 500	02->06	A
SCARABEO 500 LIGHT	06->08	A
SCARABEO 500 URBAN	06->11	A
DERBI	Year	A/P
BOULEVARD 125 S	07->	A
RAMBLA 125	09->11	A
RAMBLA 250	09->	A
RAMBLA 300	10->11	A

### DF4039 A

ØE:280 ØC:170 ØI:155 ØF:6,5 N°:6 SP:4

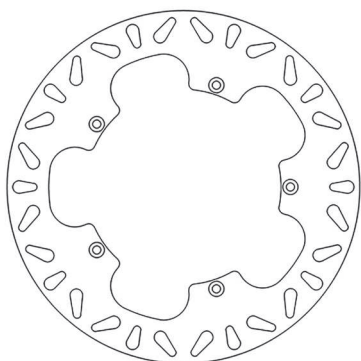

APRILIA	Year	A/P
RS 50 REPLICA	00->05	A
TUONO 50	03->04	A

### DF4040 A

ØE:180 ØC:80 ØI:62,6 ØF:10,5 N°:3 SP:3,5

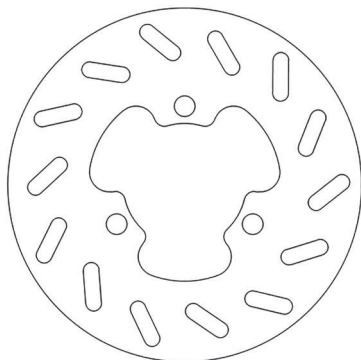

DERBI	Year	A/P
FENIX 50	95->98	P
SENDA 50 EX	95->97	P
SENDA 50 L	99->	P
SENDA 50 R	97->99	P
SENDA 50 R RACER	02->	P
SENDA 50 R XTREAM	00->01	P
SENDA 50 SM RACER	02->	P

...DF4040		
... segue DERBI	Year	A/P
SENDA 50 SM XTREAM	00->01	P
SENDA 50 SR	99->00	P
SENDA 50 SUPERMOTARD	97->99	P

### DF4042 A

ØE:240 ØC:140 ØI:125,5 ØF:6,5 N°:5 SP:4

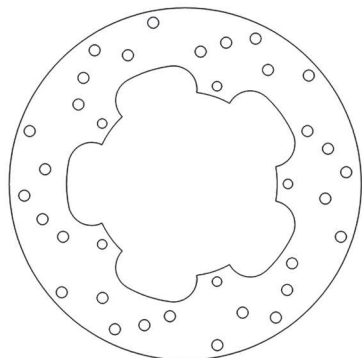

GILERA	Year	A/P
DNA 50	00->07	A
DNA 50 GP EXPERIENCE	03->04	A
DNA 125	01	A
RUNNER 125 FX - FXR	97->02	P
RUNNER 125 SP	99->	P
RUNNER 180 FXR	98->	P
RUNNER 180 SP	99->	P
PIAGGIO	Year	A/P
X9 125 EVOLUTION	01->07	A/P
X9 125 EVOLUTION (pinza HengTong)	01->	A/P
X9 180 AMALFI	00->03	A/P
X9 200 EVOLUTION	02->03	A/P
X9 250	00->03	A/P
X9 250 AMALFI	00->	A/P
X9 250 EVOLUTION	04->06	A/P

### DF4043 A

ØE:180 ØC:80 ØI:58,2 ØF:11,8 N°:3 SP:3,5

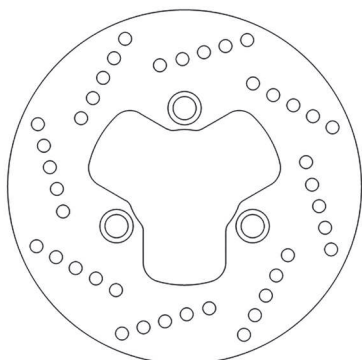

PEUGEOT	Year	A/P
SPEEDFIGHT 50 (raff. acqua pinza AJP)	98->	A/P
SPEEDFIGHT 50 M (Pinza AJP)	97->98	A
SPEEDFIGHT 100	97->00	A/P

### DF4045 A

ØE:230 ØC:136 ØI:116 ØF:8,6 N°:3 SP:5

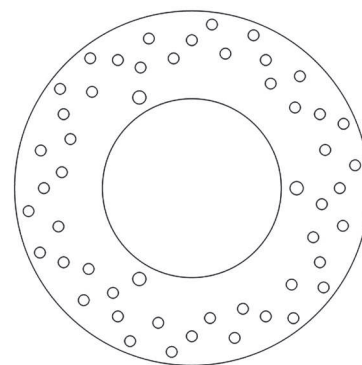

MBK	Year	A/P
YP 250 SKYLINER	00->03	P
YAMAHA	Year	A/P
MAJESTY 250 YP	00->03	P
MAJESTY 250 YP ABS	03->	P

### DF4050 A AF

ØE:260 ØC:101,6 ØI:90,5 ØF:6,5 N°:6 SP:4

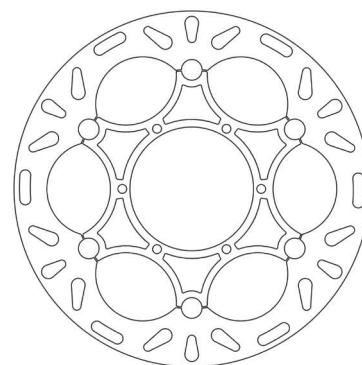
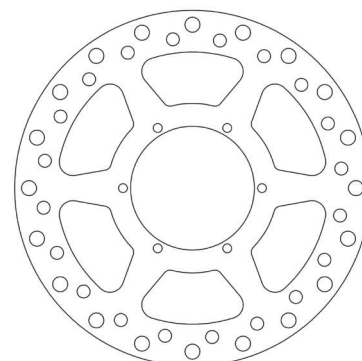

CAGIVA	Year	A/P
MITO 50	98->01	A
DERBI	Year	A/P
GPR 50 NUDE	04->05	A
GPR 50 R	97->01	A
GPR 50 RACING	04->	A

**DF4051**

**AF**

ØE:260 ØC:125 ØI:108,6 ØF:6,5 N°:6 SP:3,5

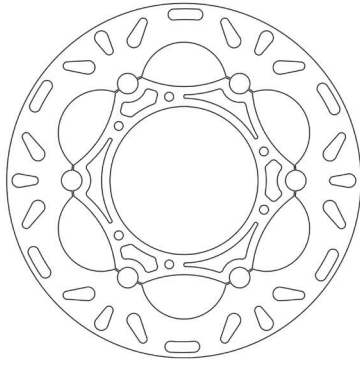

BULTACO	Year	A/P
ASTRO 50	99->00	A
LOBITO 50	99->14	A
DERBI	Year	A/P
SENDA 50 SM XTREAM	00->01	A
SENDA 50 SUPERMOTARD	00->	A
MALAGUTI	Year	A/P
CRW 50 ENDURO	03->	A

**DF4052**

**A**

ØE:218 ØC:115,5 ØI:90,5 ØF:8,5 N°:3 SP:3,5

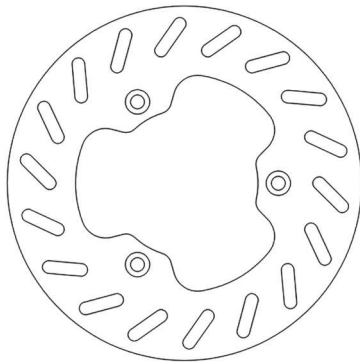

DERBI	Year	A/P
SENDA 50	94->	A
SENDA 50 L 6V	94->97	A
SENDA 50 R	98->99	A
SENDA 50 R 6V	94->97	A
SENDA 50 R RACER	02->	A
SENDA 50 SM RACER	02->	A
SENDA 50 SR	01->	A
SENDA 50 SUPERMOTARD	97->99	A
YUMBO 50 FDS SAVANNAH	88->	A

**DF4053**

**A**

ØE:220 ØC:80,1 ØI:57,5 ØF:6,5 N°:6 SP:4

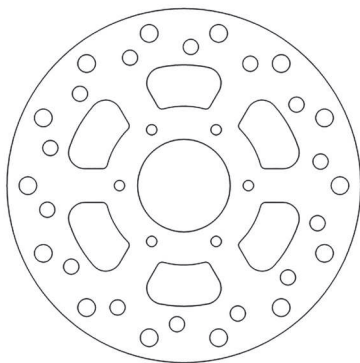

CAGIVA	Year	A/P
MITO 50	98->01	P
PRIMA 75 R	98->01	P

**DERBI**

...DF4053

GPR 50 R 97->01 P

**DF4055**

**A**

ØE:240 ØC:140 ØI:125,5 ØF:6,5 N°:5 SP:5

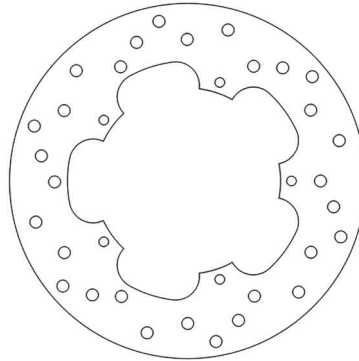

GILERA	Year	A/P
NEXUS 500	03->05	P
PIAGGIO	Year	A/P
MP3 125	06->08	P
MP3 125 IBRIDO	09->12	P
MP3 125 IE	08->09	P
MP3 125 IE TOURING	11->12	P
MP3 125 YOURBAN ERL	11->13	P
SUPER HEXAGON 125 GTX	01->02	A
X8 125	04->	P
X8 125 (pinza HengTong)	05->06	P
X8 125 (pinza HengTong)	05->06	P
X8 125 PREMIUM EURO 2	06->	P
SUPER EXAGON 180 GTX	01->04	A
X8 200	04->06	P
X8 200 (pinza HengTong)	05->	P
MP3 250	06->08	P
MP3 250 LT	08->09	P
MP3 250 MIC	08->09	P
MP3 300 4T 4V IE ERL IBRIDO	10->13	P
MP3 300 4T 4V IE LT IBRIDO	10->11	P
MP3 300 IE LT	10->11	P
MP3 300 IE LT - IE LT SPORT	11->13	P
MP3 300 IE LT TOURING	11->13	P
MP3 300 IE MIC	10->11	P
MP3 300 IE TOURING	11->12	P
MP3 300 LT BUSINESS ABS	14	P
MP3 300 SPORT ABS	14	P
MP3 300 YOURBAN ERL	11->15	P
MP3 300 YOURBAN LT ERL	11->12	P
BEVERLY 400 EURO 3	06->08	P
MP3 400	07->08	P
MP3 400 IE LT - IE LT SPORT	08->10	P
MP3 400 IE LT TOURING	11	P
MP3 400 LT	09->	P
MP3 400 MIC	08->10	P
MP3 400 RL TOURING	11	P
BEVERLY 500	02->06	P
BEVERLY 500 CRUISER	07->12	P
BEVERLY 500 EURO 3	06->	P
MP3 500 LT SPORT - BUSINESS	11->13	P
MP3 500 RL SPORT - BUSINESS	11->12	P
X9 500	01->03	P
X9 500 EVOLUTION	03->04	P
X9 500 EVOLUTION ABS	06->07	P

**DF4056**

**A**

ØE:260 ØC:140 ØI:125 ØF:6,5 N°:5 SP:4

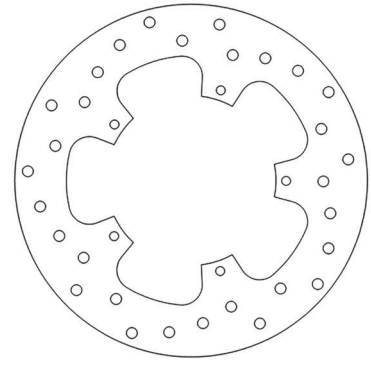

APRILIA	Year	A/P
SR 300 MAX	10->18	A
GILERA	Year	A/P
NEXUS 125 EURO 3	07->	A
NEXUS 125 IE EURO 3	08->11	A
NEXUS 250 EURO 3	06->	A
NEXUS 300 EURO 3	08->11	A
NEXUS 500	03->05	A
NEXUS 500 EURO 3	06->11	A
NEXUS 500 SP EURO 3	06->07	A
PIAGGIO	Year	A/P
BEVERLY 125 (pinza Grimeca)	01->	A / P
BEVERLY 125 (pinza HengTong)	01->	A / P
BEVERLY 125 EURO 3	07->08	A / P
BEVERLY 125 EURO 3 MIC	07	A / P
BEVERLY 125 EURO 3 SPORT	07->08	A / P
BEVERLY 125 EURO 3 TOURER	08->10	A / P
BEVERLY 125 RST	04->07	A / P
BEVERLY 125 RST 4T 4V IE EURO 3	10->11	A / P
CARNABY 125	07->10	A / P
X EVO 125	07->12	A
X7 125	07->09	A
X7 125 EURO3	08->09	A
X7 125 EVO IE EURO3	09->10	A
X8 125	04->	A
X8 125 (pinza HengTong)	05->06	A
X8 125 (pinza HengTong)	05->06	A
X8 125 PREMIUM EURO 2	06->	A
X8 125 STREET EURO 3	06->	A
X8 150 STREET EURO 3	06->	A
BEVERLY 200 (pinza Grimeca)	01->06	A / P
BEVERLY 200 (pinza HengTong)	01->06	A / P
CARNABY 200	07->10	A / P
X8 200	04->06	A
X8 200 EVO	05->07	A
BEVERLY 250	06->07	A / P
BEVERLY 250 CRUISER	07->09	A / P
BEVERLY 250 EURO 3 IE	06->08	A / P
BEVERLY 250 EURO 3 MIC	07	A / P
BEVERLY 250 EURO 3 TOURER	08->09	A / P
BEVERLY 250 LEADER	04	A / P
BEVERLY 250 RST	04->05	A / P
BEVERLY 250 SPORT	06->08	A / P
CARNABY 250	08->	A / P
X EVO 250 EVO	07->13	A
X7 250 EURO 3	08->	A
X8 250	05->	A
BEVERLY 300 TOURER EURO 3	09->10	A / P
CARNABY 300 CRUISER	09->	A / P
X7 300 EVO IE	11->	A
X7 300 EVO IE EURO3	09->11	A
BEVERLY 400 TOURER EURO3	08->10	A
X8 400	06	A
X8 400 EURO 3	06->08	A
BEVERLY 500	02->06	A
BEVERLY 500 CRUISER	07->12	A
BEVERLY 500 EURO 3	06->	A
X9 500	01->03	A

FIGURATO DISCHI FRENO CON APPLICAZIONI | BRAKE DISCS DRAWINGS AND APPLICATIONS | DESSINS DISQUES DE FREIN AVEC APPLICATIONS |  
DISEÑOS DISCOS DE FRENO CON RELACION | ZEICHNUNGEN VON BREMSSCHEIBEN MIT VERWENDUNGSLISTE





## DF4058 A

ØE:220 ØC:80 ØI:60 ØF:8,5 N°:3 SP:4

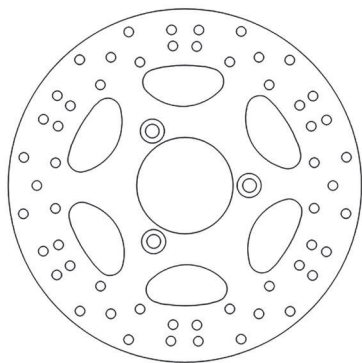

MALAGUTI	Year	A/P
F 18 125 WARRIOR	00->02	A
F 18 150 WARRIOR	00->02	A

## DF4059 A

ØE:220 ØC:125 ØI:105 ØF:10,5 N°:4 SP:4

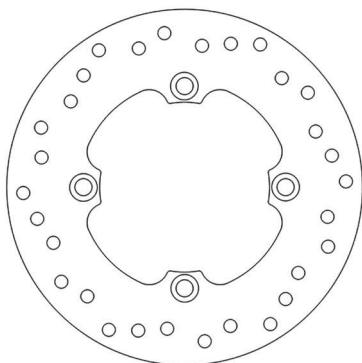

HONDA	Year	A/P
@ 125 NES (tambuto post/rear drum)	00->	A
DYLAN 125 SES	01->07	A
PSi 125	06->13	A
SH 125 (tambuto post/rear drum)	00->08	A
@ 150 NES (tambuto post/rear drum)	00->	A
DYLAN 150 SES	01->06	A
PSi 150	06->11	A
SH 150 (tambuto post/rear drum)	00->08	A

## DF4060 A

ØE:220 ØC:125 ØI:105 ØF:10,5 N°:4 SP:5

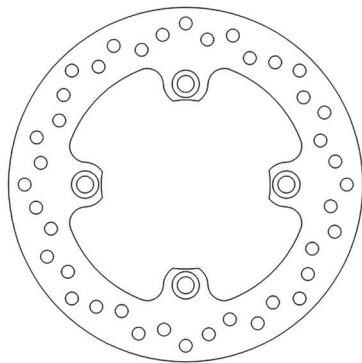

HONDA	Year	A/P
CBR 125 R	04->10	P
PANTHEON 125 FES	03->07	P
S-WING 125 FES	08->	P
PANTHEON 150 FES	03->07	P
S-WING 150 FES	07->	P
CRM 250 R	91->96	P

## ...DF4060

... segue HONDA	Year	A/P
FORESIGHT 250 FES	99->07	P
FORZA 250 NSS	00->04	P
JAZZ 250	01->04	P
XLR 250 R	91->	P
XR 250 R	90->04	P
CB-1 400 F	89->90	P
XR 400 R	96->05	P
XR 400 SUPERMOTARD	05->08	P
XR 440 R (DALLARA)	99->	P
XR 500 R	83->85	A
CB 600 F HORNET	98->06	P
CB 600 F HORNET S	00->04	P
CBR 600 F	91->13	P
CBR 600 F4 / FS / FR SPORT	01->02	P
CBR 600 RR ABS	09->17	P
XR 600 L - R	93->00	P
XR 600 R	91->92	P
NX 650 DOMINATOR	88->92	P
CBR 900 RR FIREBLADE (918 cc)	95->97	P
CBR 900 RR-FIREBLADE (893 cc)	92->94	P
CBR 900 RR-FIREBLADE (929 cc)	00->03	P
CBR 1000 RR FIREBLADE	06->16	P
CBR 1000 RR FIREBLADE ABS	09->16	P
CBR 1000 RR SP	14->16	P
VTR 1000 F FIRESTORM	97->07	P
VTR 1000 SP	00->07	P

## DF4061 A

ØE:270 ØC:101 ØI:90 ØF:6,5 N°:6 SP:4

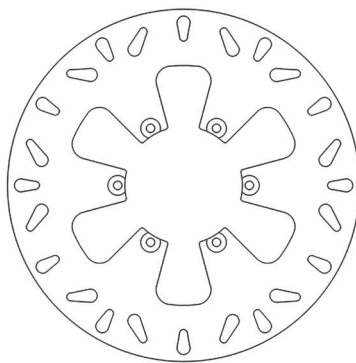

MALAGUTI	Year	A/P
MADISON K 400	02	A
MADISON K 400 RESTYLING	02->04	A

## DF4062 A

ØE:220 ØC:125 ØI:105 ØF:10,6 N°:3 SP:4

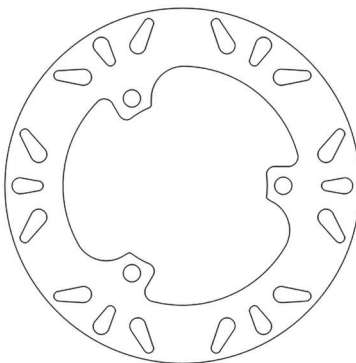

HONDA	Year	A/P
X8R S 50 SZX	98->	A
X8R X 50 SZX	98->	A

## DF4064 A

ØE:220 ØC:80 ØI:58 ØF:10,5 N°:5 SP:4

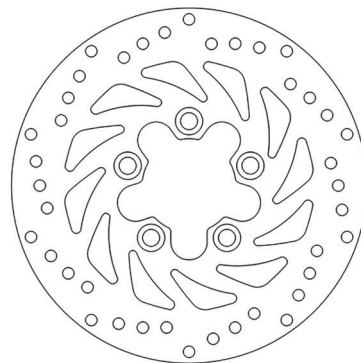

KYMCO	Year	A/P
B&W 50 EURO 2	03->06	A
DINK 50	97	A
DINK 125	00->05	A
GRAND DINK 125	01->04	A
MOVIE 125	99->00	A
MOVIE 125 EURO 3	06->09	A
MOVIE 125 XL	01->09	A
DINK 150 CLASSIC	02	A
DINK 150 CLASSIC EURO 2	03	A
GRAND DINK 150	01->04	A
MOVIE 150 EURO 3	06->07	A
MOVIE 150 XL	01->04	A
DINK 200 CLASSIC	04	A
B&W 250 BET & WIN	00->02	A
B&W 250 EURO 2	03	A
GRAND DINK 250	01->02	A
GRAND DINK 250 EURO 2	03->04	A
YUP 250	03->	A

## DF4065 A

ØE:200 ØC:80 ØI:58,2 ØF:10,6 N°:5 SP:4

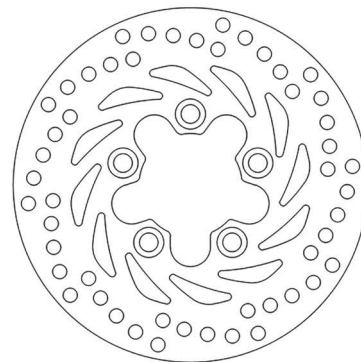

KYMCO	Year	A/P
NEW DINK 200	08->	P
GRAND DINK 250	01->02	P

**DF4066**

**A**

ØE:190 ØC:79,5 ØI:58,2 ØF:10 N°:3 SP:4

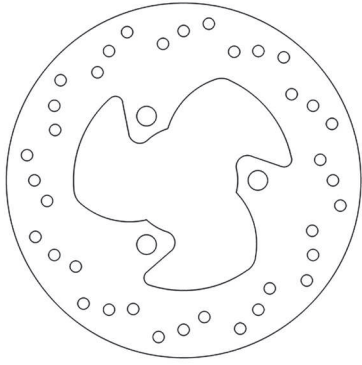

BENELLI	Year	A/P
491 50 all models	97->	A
K2 50 all models	98->	A
K2 100	99->	A
NAKED 100	99->02	A
HONDA	Year	A/P
SKY 50	97->	A
SKY 50 VETRO	00->	A
MBK	Year	A/P
CW 50 RS BOOSTER NG	99->03	A
EW 50 STUNT	00->02	A
YQ 50 NITRO	97->03	A/P
YQ 100 NITRO	00->02	A
PEUGEOT	Year	A/P
VIVACITY 50 CATALITICO	02->04	A
VIVACITY 50 VSX-XR	02->04	A
LOOXOR 100	01->	P
YAMAHA	Year	A/P
AEROX LC 50 YQ	97->12	A/P

**DF4067**

**A**

ØE:190 ØC:80 ØI:63,2 ØF:8,7 N°:3 SP:5

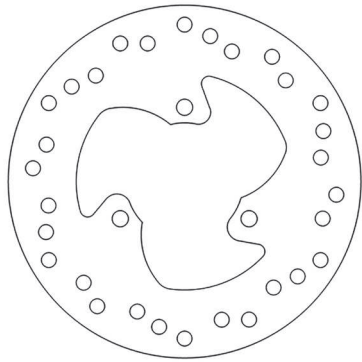

MBK	Year	A/P
YP 125 SKYLINER	01->	P
YP 150 SKYLINER	01->02	P
YP E 180 SKYLINER	03	P
YAMAHA	Year	A/P
MAJESTY 125 YP E	01->09	P
MAJESTY 150 YP	01->02	P
MAJESTY 180 YP E	03->06	P

**DF4068**

**A**

ØE:190 ØC:94 ØI:72 ØF:10,5 N°:4 SP:4

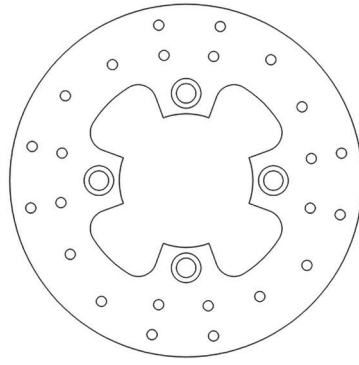

HONDA	Year	A/P
CH 250 SPACY (spessore disco 4mm)	00->	A

**DF4069**

**A**

ØE:220 ØC:125 ØI:110 ØF:6,5 N°:6 SP:4

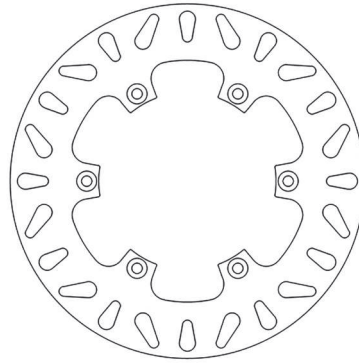

GILERA	Year	A/P
GSM 50 (motore Derbi)	01->	A
H@C 50	99->	A
SURFER 50	99->	A
ZULU 50	01->	A

**DF4070**

**A**

ØE:184 ØC:72 ØI:59 ØF:6,5 N°:6 SP:4

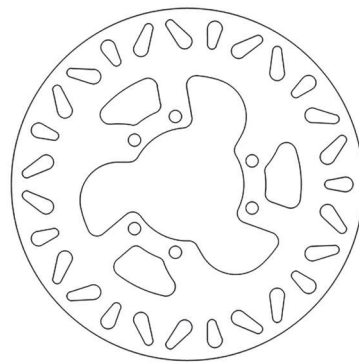

GILERA	Year	A/P
GSM 50 (motore Derbi)	01->	P
H@C 50	99->	P
ZULU 50	01->	P

**DF4073**

**A**

ØE:220 ØC:95,2 ØI:72,1 ØF:7 N°:6 SP:3,5

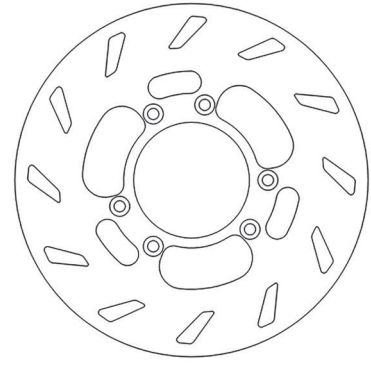

BETA	Year	A/P
RK 50 6 T	98->	A

**DF4075**

**A**

ØE:245 ØC:134 ØI:118,7 ØF:6,5 N°:6 SP:3

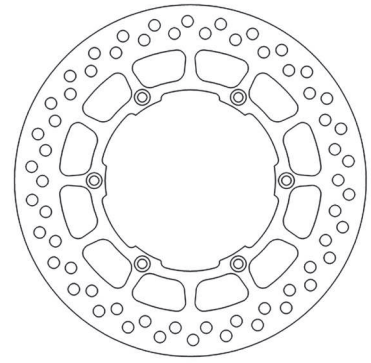

BETA	Year	A/P
MX R 50 ENDURO	95->96	P
RK 50 6 - E	95->97	P
RK 50 ADVENTURE	95->96	P

**DF4076**

**A**

ØE:220 ØC:86,1 ØI:64,6 ØF:10,5 N°:4 SP:4

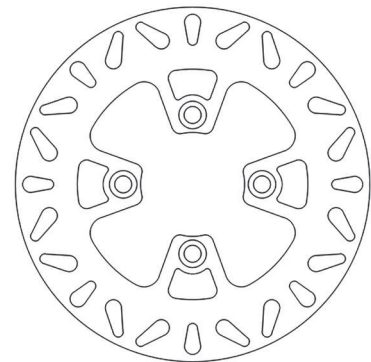

SUZUKI	Year	A/P
BURGMAN 125 UH	02->06	P
BURGMAN 150 UH	02->06	P

## DF4077

A

ØE:270 ØC:146 ØI:128,2 ØF:8,6 N°:5 SP:5

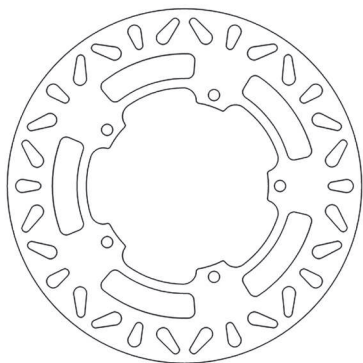

MBK	Year	A/P
KILIBRE 300	03->06	A
YAMAHA	Year	A/P
VERSITY 300 XC	03->06	A

## DF4078

A

ØE:240 ØC:114 ØI:92,2 ØF:8,6 N°:4 SP:5

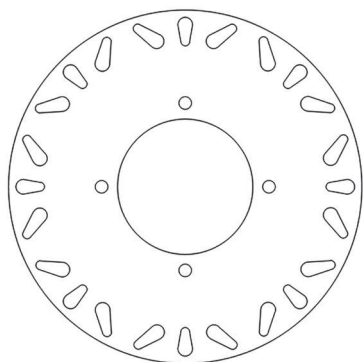

MBK	Year	A/P
KILIBRE 300	03->06	P
YAMAHA	Year	A/P
X-CITY 125 VP	08->13	P
X-MAX R 125 YP	06->13	P
X-CITY 250 VP	07->14	P
X-MAX R 250 YP	05->13	P
X-MAX R 250 YP BLACK	09	P
X-MAX R 250 YP SPORT	11->12	P
VERSITY 300 XC	03->06	P

## DF4079

A

ØE:203 ØC:102 ØI:84,3 ØF:8,5 N°:4 SP:4,5

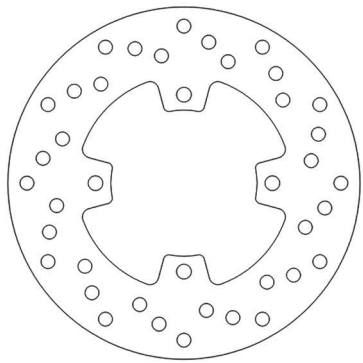

YAMAHA	Year	A/P
TZR 50	96->02	P

## DF4080

A

ØE:260 ØC:110 ØI:88 ØF:10,5 N°:5 SP:4

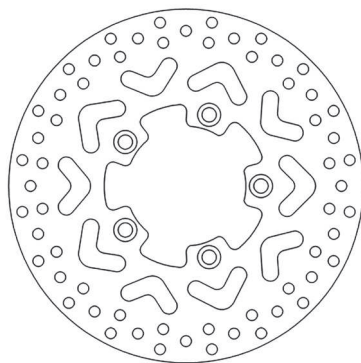

KYMKO	Year	A/P
AGILITY 50 2T PLUS	14->	A
AGILITY 50 2T R 16	10->13	A
AGILITY 50 4T PLUS	14->	A
AGILITY 50 4T R 16	08->15	A
PEOPLE S 50	05->08	A
PEOPLE S 50 4T	06->08	A
AGILITY 125 R 16	08->12	A
AGILITY 125 R 16+	14->16	A
PEOPLE 125 EURO 2	03->04	A
PEOPLE 125 EURO 3	07->	A
PEOPLE S 125	05->06	A
PEOPLE S 125 DD	07->08	A/P
AGILITY 150 R 16	08->	A
PEOPLE S 200	05->06	A
PEOPLE S 200 I	07->	A/P
PEOPLE 250	03->05	A/P
PEOPLE S 250	06->	A/P
PEOPLE S 250 i	07->	A/P
PEOPLE S 300 I	08->10	A/P

## DF4081

A

ØE:220 ØC:119,5 ØI:100,5 ØF:10,5 N°:3 SP:4

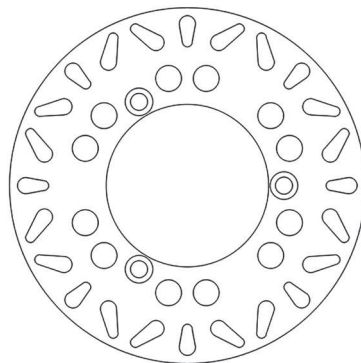

SUZUKI	Year	A/P
BURGMAN 125 UH	02->06	A
BURGMAN 150 UH	02->06	A

## DF4082

A

ØE:240 ØC:120 ØI:105,2 ØF:6,4 N°:5 SP:5

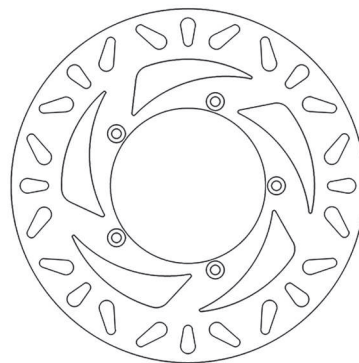

APRILIA	Year	A/P
ATLANTIC 125	03->11	A
ARECIFE 200 (spagna)	03->	A
ATLANTIC 200	03->05	A
ATLANTIC 250	03->06	A
ATLANTIC 300	10->11	A
BENELLI	Year	A/P
VELVET 250	99->	A
VELVET 250 TOURING	01->	A
VELVET 400 DUSK	03->	A

## DF4083

A

ØE:189,5 ØC:88,7 ØI:69,5 ØF:8,4 N°:3 SP:4

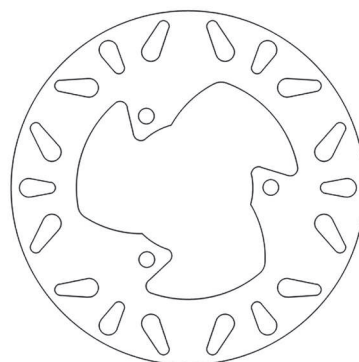

APRILIA	Year	A/P
SR 50 R FACTORY (motore Piaggio)	04->05	P
ATLANTIC 125	03->11	P
ARECIFE 200 (spagna)	03->	P
ATLANTIC 200	03->05	P
ATLANTIC 250	03->06	P
ATLANTIC 300	10->11	P

## DF4084

A

ØE:260 ØC:141,9 ØI:121,2 ØF:10,3 N°:5 SP:4,4

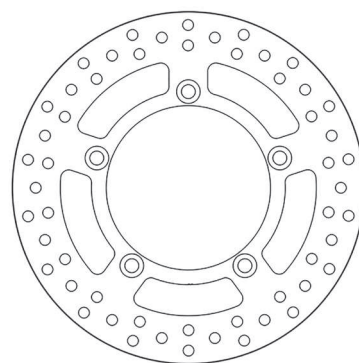

SUZUKI	Year	A/P
BURGMAN 250 AN	03->06	A
BURGMAN 400 AN	03->06	A

...DF4084		
... segue SUZUKI	Year	A/P
BURGMAN 400 AN	07->19	A
BURGMAN 650 AN	04->12	A

DF4085		A	ASM
ØE:210	ØC:135	ØI:120,2	ØF:6,2 N°:6 SP:5

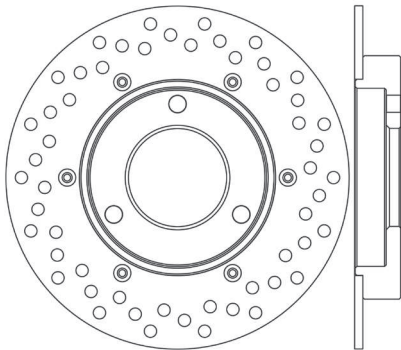
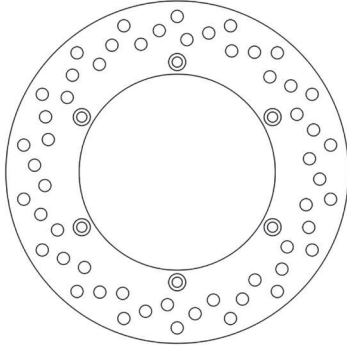

SUZUKI	Year	A/P
BURGMAN 250 AN	03->06	P
BURGMAN 400 AN	03->06	P

DF4086		A
ØE:250	ØC:137,3	ØI:116,6 ØF:10,3 N°:5 SP:5

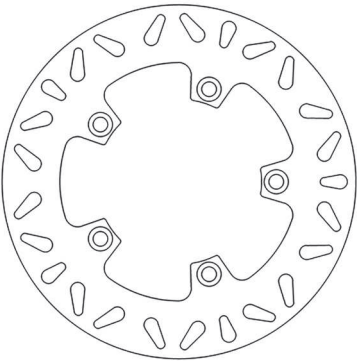

SUZUKI	Year	A/P
BURGMAN 650 AN	04->20	P

DF4087		A
ØE:180	ØC:66	ØI:48 ØF:8,6 N°:3 SP:4 OS:10

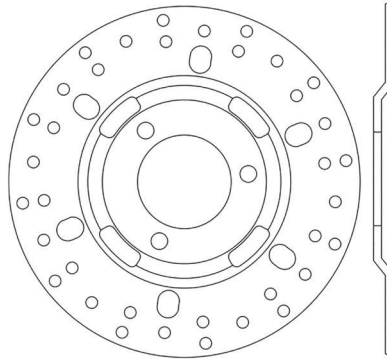

MBK	Year	A/P
YW 100 BOOSTER	99->01	A
XC 125 FLAME R	96->99	A

YAMAHA	Year	A/P
BW S 100	99->01	A
CYGNUS R 125 XC	99->03	A
CYGNUS R 125 XC K	97->98	A
FLY ONE R 150 XC	98->	A

DF4088		A
ØE:267	ØC:150	ØI:132 ØF:8,5 N°:5 SP:5

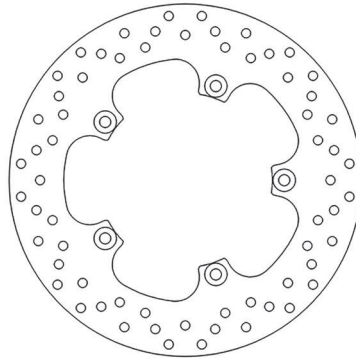

YAMAHA	Year	A/P
X-MAX R 125 YP	06->17	A
X-MAX R 125 YP ABS	11	A
X-MAX RA 125 YP ABS	13->17	A
X-MAX R 250 YP	05->16	A
X-MAX R 250 YP BLACK	09	A
X-MAX R 250 YP SPORT	11->12	A
X-MAX RA 250 YP ABS	11->16	A
MAJESTY 400 YP	04	A
FZ8 N 800	11->15	P
FZ8 NA 800	11->15	P
FZ8 S 800 FAZER	11->15	P
FZ8 SA 800 FAZER	11->15	P

DF4089		AF
ØE:267	ØC:149,8	ØI:132,6 ØF:8,6 N°:5 SP:4

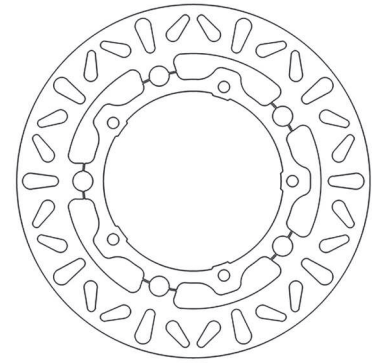

YAMAHA	Year	A/P
MAJESTY 400 YP	05->11	A
MAJESTY 400 YP ABS	09->11	A
X-MAX R 400 YP	13->16	A
X-MAX R 400 YP MOMODESIGN	14	A
X-MAX RA 400 YP ABS	14->17	A
X-MAX RA 400 YP ABS MOMODESIGN	14	A
T MAX 500 XP	04->07	A
T MAX 500 XP ABS	05->07	A
T MAX 530 XP	12->17	A
T MAX 530 XP ABS	15->16	A
T MAX DX 530 XP	17->19	A
T MAX SP 530 XP	15	A
T MAX SP 530 XP ABS	15->16	A
T MAX SX 530 XP	17->19	A

DF4090		AF
ØE:270	ØC:101	ØI:90,1 ØF:6,5 N°:6 SP:5

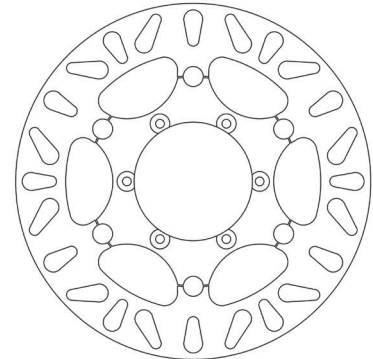

MALAGUTI	Year	A/P
PASSWORD 250	05->06	A
PASSWORD 250 EU 3	07->08	A
SPIDERMAX 500 GT	04->05	A
SPIDERMAX 500 GT EURO 3	06	A
SPIDERMAX 500 RS	08->	A

## DF4091

A

ØE:260 ØC:135 ØI:120,1 ØF:6,3 N°:6 SP:4

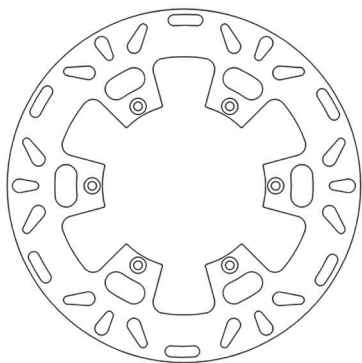

MALAGUTI	Year	A/P
SPIDERMAX 500 GT	04->05	P
SPIDERMAX 500 GT EURO 3	06	P
SPIDERMAX 500 RS	08->	P

## DF4092

A

ØE:240 ØC:120 ØI:105,2 ØF:6,5 N°:5 SP:4

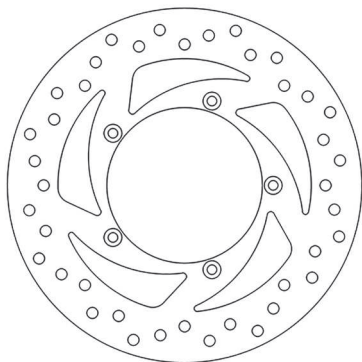

MALAGUTI	Year	A/P
MADISON 3 125	06->09	A / P
MADISON 3 250	06->09	A / P
PASSWORD 250	05->06	P
PASSWORD 250 EU 3	07->08	P

## DF4093

AF

ØE:260 ØC:142 ØI:121,3 ØF:10,3 N°:4 SP:4,5

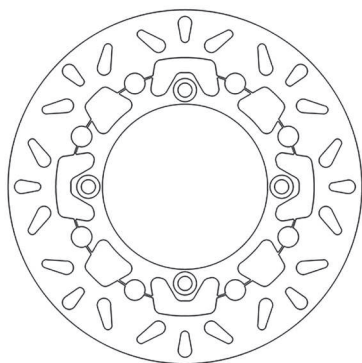

SUZUKI	Year	A/P
BURGMAN 650 AN	02->03	A

## DF4094

AF

ØE:260 ØC:101 ØI:90 ØF:6,5 N°:6 SP:4

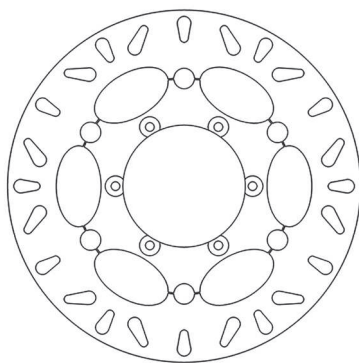

MALAGUTI	Year	A/P
MADISON 125	99->02	A
PHANTOM MAX 125	03->	A
MADISON T 150	99->01	A
MADISON R 180	01->02	A
MADISON 200	99->01	A
MADISON S 200 RESTYLING	02->03	A
PHANTOM MAX 200	03	A
MADISON RS 250 RESTYLING	04	A
PHANTOM MAX 250	04	A

## DF4095

AF

ØE:250 ØC:80 ØI:58 ØF:6,5 N°:5 SP:4

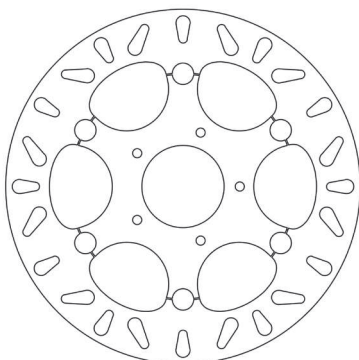

GILERA	Year	A/P
RUNNER 125	97->99	A
RUNNER 125 FX - FXR	97->02	A
RUNNER 125 SP	99->	A
RUNNER 125 VX / VXR 4T	01->04	A
RUNNER 180	97->98	A
RUNNER 180 FXR	98->	A
RUNNER 180 SP	99->	A
RUNNER 180 VXR	01->04	A
RUNNER 200 VXR 4T (pinza Heng Tong)	01->06	A
RUNNER 200 VXR 4T RACE	05->06	A
RUNNER 200 VXR 4T ST EURO 3	08->11	A

## DF4097

AF

ØE:260 ØC:125 ØI:105 ØF:10,6 N°:4 SP:4

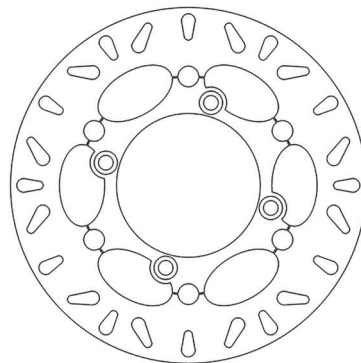

HONDA	Year	A/P
@ 125 NES (tambuto post/rear drum)	00->	A
SH 125 (tambuto post/rear drum)	00->08	A
@ 150 NES (tambuto post/rear drum)	00->	A
SH 150 (tambuto post/rear drum)	00->08	A

## DF4099

A

ØE:220 ØC:100 ØI:82 ØF:8,3 N°:5 SP:4

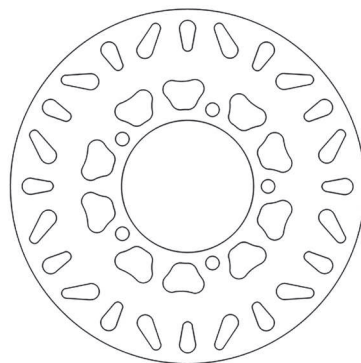

YAMAHA	Year	A/P
CYGNUS X 125 NXC	04->06	A

## DF4100

A

ØE:170 ØC:63,9 ØI:47,5 ØF:10,2 N°:3 SP:8,2

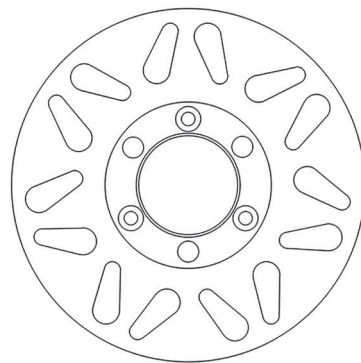

INNOCENTI	Year	A/P
LAMBRETTA 175 TV III	62->67	A
LAMBRETTA 200 DL	69->71	A
LAMBRETTA 200 GP (UK)	69->71	A
LAMBRETTA 200 GT (UK)	63->65	A
LAMBRETTA 200 SX	66->68	A
LAMBRETTA 200 TV III	63->65	A

**DF4102**

**A**

ØE:220 ØC:107 ØI:96,1 ØF:6,6 N°:5 SP:4

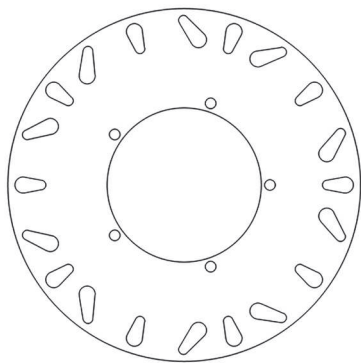

**DF4105**

**A**

ØE:226 ØC:120 ØI:105 ØF:6,3 N°:5 SP:4

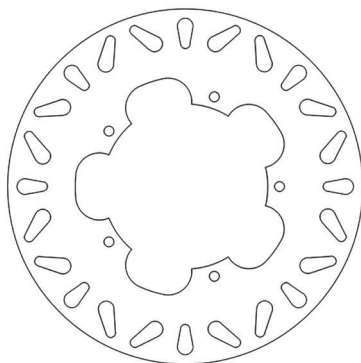

**DF4107**

**A**

ØE:220 ØC:120 ØI:97,2 ØF:10,8 N°:5 SP:4

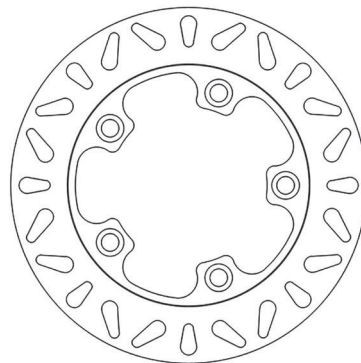

BENELLI	Year	A/P
ADIVA 125	00->02	P
ADIVA 150	00->02	P

PEUGEOT	Year	A/P
LOOXOR 50	01->	A
LOOXOR 100	01->	A
LOOXOR 125	02->	A
LOOXOR 150	02->03	A

SYM	Year	A/P
HD 125 EU 2	03->04	A
HD 125 EURO 3	07->08	A
HD EVO 125	05->06	A
HD EVO 125 EURO3	10	A
HD 200	03->	A
HD EVO 200 EURO 2	05->06	A
HD EVO 200 I EURO 3	07->10	A
HD EVO 200 I EURO 3 (tamburo post)	08->09	A

**DF4103**

**A**

ØE:256 ØC:166 ØI:144 ØF:10,5 N°:6 SP:5

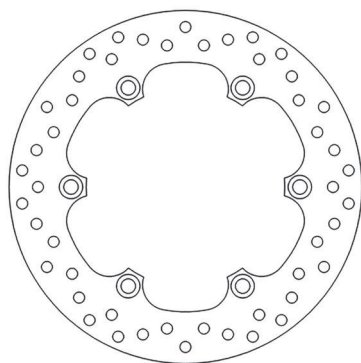

**DF4106**

**A**

ØE:273 ØC:250 ØI:173,1 ØF:10,6 N°:5 SP:4

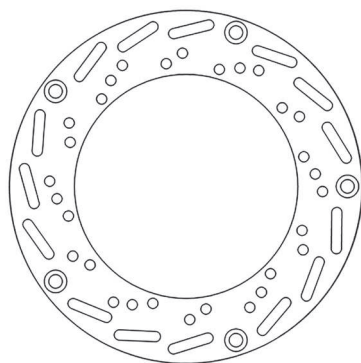

**DF4108**

**A**

ØE:200 ØC:95 ØI:73 ØF:10,5 N°:3 SP:4

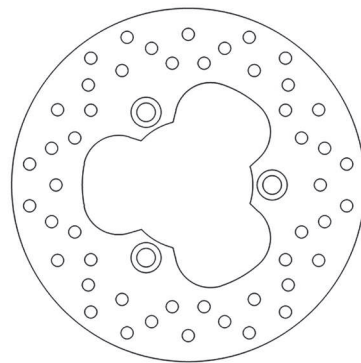

HONDA	Year	A/P
FORZA 125 NSS	15->19	A
FORZA X 250 NSS	08->13	A
FORZA XE 250 NSS	08->13	A
FORZA 300 NSS	12->	A
FORZA 300 NSS ABS	18->18	A
SH 300 i	06->14	A / P
SH 300 i ABS	06->14	P
SH 300 i ABS	06->18	A
NS 400 R	85->87	A
SILVER WING 400 FJS	06->08	A
VF 500 F	84->85	A / P
SILVER WING 600 FSC	01->07	A
VFR 750 F INTERCEPTOR	86->89	P
CBR 1000 F-PP	93->99	P
XLV 1000 VARADERO	03->11	P
XLV 1000 VARADERO ABS	04->11	P
CB 1100 SFX ELEVEN (X11)	00->03	P
CBR 1100 XX BLACKBIRD	97->98	P
CBR 1100 XX SUPERBLACKBIRD	99->08	P
CB 1300 F SUPER FOUR	03->04	P
CB 1300 SUPER BOL DOR	05->08	P
CB 1300 SUPERFOUR	05->13	P

SYM	Year	A/P
EURO 125 MX	02	A
EURO 125 MX E2	03->04	A
JOYRIDE 125	01->04	A
JOYRIDE 125 EURO 2	05->06	A
JOYRIDE 125 EURO 3	07->09	A
JOYRIDE 125 EVO	10->	A
JOYRIDE 125 S	16	A
SHARK 125	99->00	A
VS 125	06	A
VS 125 EURO 3	07->08	A
EURO MX 150	02->	A
EURO MX 150 EU 2	03->04	A
JOYRIDE 150	01->02	A
SHARK 150	00->01	A
VS 150	07	A
VS 150 EURO 3	07->08	A
JOY RIDE 200	01->04	A
JOY RIDE 200 I EVO	09->10	A

SYM	Year	A/P
GTS 125	06->07	P
GTS 125 JOYMAX	06->07	P
JOYRIDE 125	01->04	P
JOYRIDE 125 EURO 2	05->06	P
JOYRIDE 125 EURO 3	07->09	P
JOYRIDE 125 EVO	10->	P
JOYRIDE 125 S	16	P
JOYRIDE 150	01->02	P
JOY RIDE 200	01->04	P
JOY RIDE 200 I EVO	09->10	P

FIGURATO DISCHI FRENO CON APPLICAZIONI | BRAKE DISCS DRAWINGS AND APPLICATIONS | DESSINS DISQUES DE FREIN AVEC APPLICATIONS  
DISEÑOS DISCOS DE FRENO CON RELACION | ZEICHNUNGEN VON BREMSSCHEIBEN MIT VERWENDUNGSLISTE



## DF4109

A

ØE:220 ØC:132 ØI:110 ØF:10,7 N°:5 SP:5

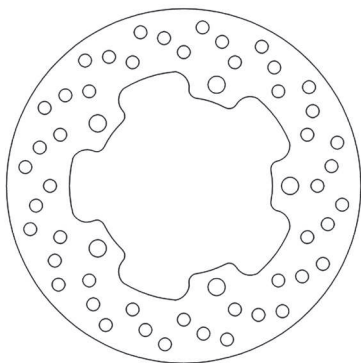

SYM	Year	A/P
HD EVO 125	05->06	P
HD EVO 125 EURO3	10	P
HD EVO 200	11->	P
HD EVO 200 EURO 2	05->06	P
HD EVO 200 I EURO 3	07->10	P
HD2 EVO 200	13->	P
GTS 250	06->08	P
JOYMAX 250	05->07	P
JOYMAX 250 I EURO 3	07->08	P
JOYMAX 300 EVO	09	P
JOYMAX 300 EVO I	10	P

## DF4110

A

ØE:240 ØC:125 ØI:98 ØF:11 N°:5 SP:4

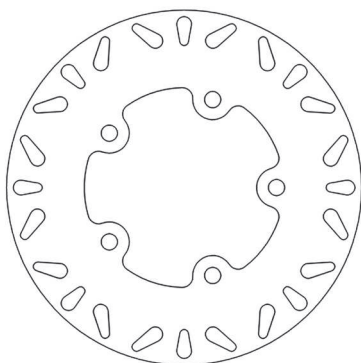

SYM	Year	A/P
GTS 125	06->07	A
GTS 125 JOYMAX	06->07	A
GTS 250	06->08	A
JOYMAX 250	05->07	A
JOYMAX 250 I EURO 3	07->08	A
JOYMAX 300 EVO	09	A
JOYMAX 300 EVO I	10	A

## DF4111

A

ØE:210 ØC:110 ØI:89,2 ØF:10,5 N°:5 SP:5

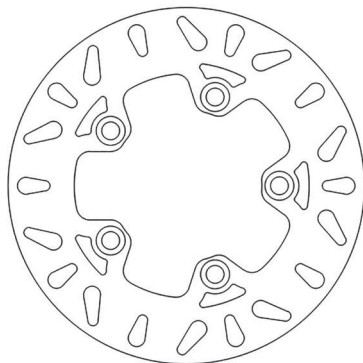

SUZUKI	Year	A/P
BURGMAN 400 AN	07->19	P

## DF4112

AF

ØE:267 ØC:150 ØI:132,1 ØF:8,6 N°:6 SP:4

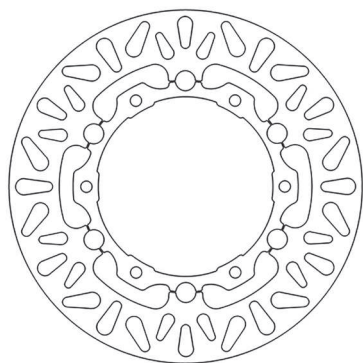

YAMAHA	Year	A/P
T MAX 500 XP	08->11	A
T MAX 500 XP ABS	08->11	A
T MAX SV 500 XP	11	A
T MAX SV 500 XP ABS	10->11	A

## DF4113

A

ØE:240 ØC:110 ØI:88 ØF:10,5 N°:5 SP:4

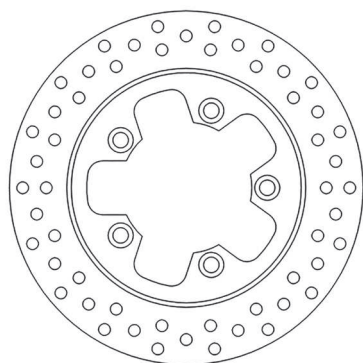

KYMCO	Year	A/P
DINK 50 4T	07	A
AGILITY 125 R 16	08->12	P
DINK 125 EURO 3	06->07	A
AGILITY 150 R 16	08->	P
AGILITY 200 i R 16	09->11	P
DINK 200 EURO 3 i	06->07	A
NEW DINK 200	08->	A
G-DINK 300	12->	A
SUPER DINK 300	09->11	P

## DF4114

A

ØE:270 ØC:146,2 ØI:128,3 ØF:8,6 N°:6 SP:5

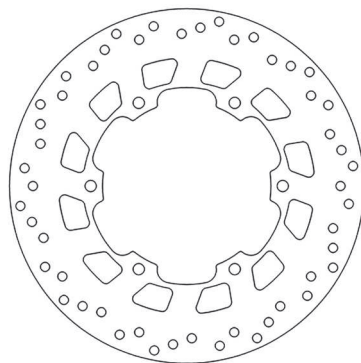

YAMAHA	Year	A/P
X-CITY 125 VP	08->13	A
X-CITY 250 VP	07->14	A

## DF4115

A

ØE:240 ØC:125 ØI:105 ØF:10,5 N°:4 SP:4

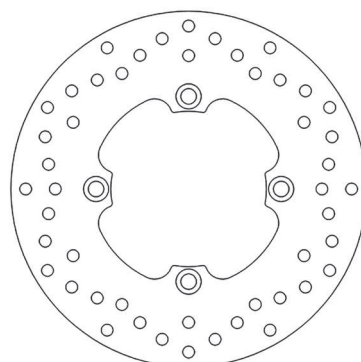

HONDA	Year	A/P
@ 125 NES	09->	A
PANTHEON 125 FES	98->07	A
S-WING 125 FES	08->	A
SH 125 i	09->18	A
@ 150 NES	09->	A
PANTHEON 150 FES	98->07	A
S-WING 150 FES	07->	A
SH 150 i	09->18	A
FORESIGHT 250 FES	97->07	A
FORZA 250 NSS	00->04	A
FORZA X 250 NSS	05->07	A
FORZA XE 250 NSS	05->07	A
JAZZ 250	01->04	A

PEUGEOT	Year	A/P
SV 250	01->	A

**DF4118**

**A**

ØE:260 ØC:130 ØI:105,2 ØF:10,6 N°:5 SP:5

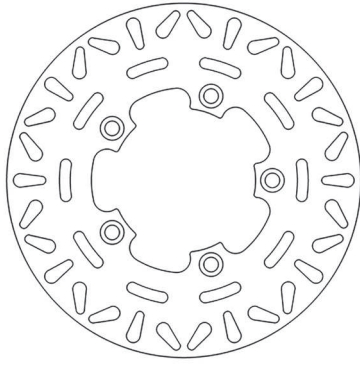

**DF4121**

**A**

ØE:267 ØC:150 ØI:132 ØF:8,5 N°:3 SP:5

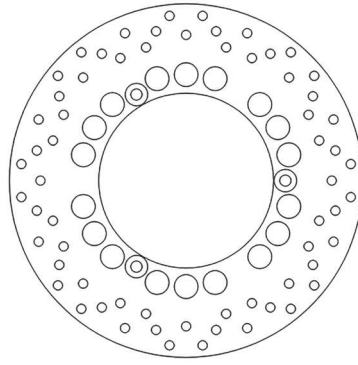

**DF4124**

**A**

ØE:220 ØC:120 ØI:105,2 ØF:6,3 N°:5 SP:4,5

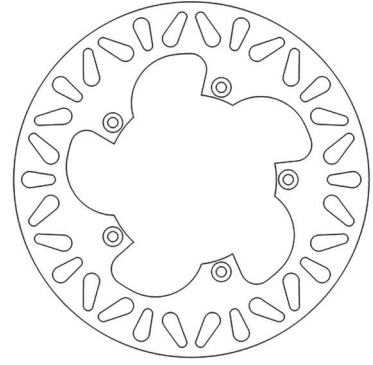

KYMCO	Year	A/P
XCITING 250	05	A
XCITING 250 i	06->	A
XCITING 300 I	08->	A
XCITING 300 I R	08->09	A
XCITING 500	05	A
XCITING 500 I	06->08	A
XCITING 500 I R	07->	A
XCITING 500 R	09->	A

YAMAHA	Year	A/P
MAJESTY 400 YP	04	P
MAJESTY 400 YP	05->11	P
MAJESTY 400 YP ABS	09->11	P

BENELLI	Year	A/P
PEPE 50	99->04	A
PEPE 100 LX	02->	A
ADIVA 125	00->02	A
VELVET 125	99->04	A
VELVET 125 TOURING	02->03	A
ADIVA 150	00->02	A
VELVET 150	99->04	A
VELVET 150 TOURING	02->03	A

**DF4123**

**A**

ØE:226 ØC:90 ØI:59,1 ØF:10,5 N°:5 SP:4

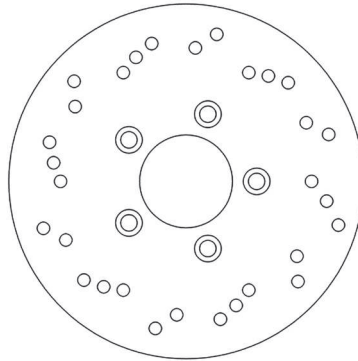

**DF4119**

**A**

ØE:240 ØC:110 ØI:88 ØF:10,6 N°:5 SP:5

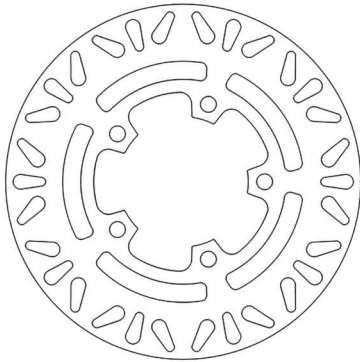

KYMCO	Year	A/P
DOWNTOWN 125 I	09->15	P
K-XCT 125 I	14->	P
DOWNTOWN 200 I	10->15	P
DOWNTOWN 300 ABS	10->11	P
DOWNTOWN 300 I	09->11	P
DOWNTOWN 300 I ABS	10->11	P
K-XCT 300 I ABS	12->14	P

SYM	Year	A/P
JET 4 50	09->10	A
SYMPHONY 50	09	A
SYMPHONY 50 S	10->	A
JET 4 125	09	A
SYMPHONY 125	09	A
SYMPHONY 125 DD	09	A
SYMPHONY 125 S	10->17	A
SYMPHONY 150	09	A
SYMPHONY 150 S	10	A

**DF4125**

**A**

ØE:240 ØC:110 ØI:89 ØF:10,4 N°:3 SP:4,5

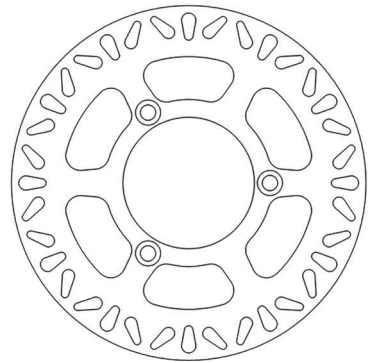

SUZUKI	Year	A/P
BURGMAN 125 UH	07->14	A / P
BURGMAN 200 UH	07->13	A / P

**DF4126**

**EF**

ØE:245 ØC:100 ØI:82 ØF:8,8 N°:5 SP:4

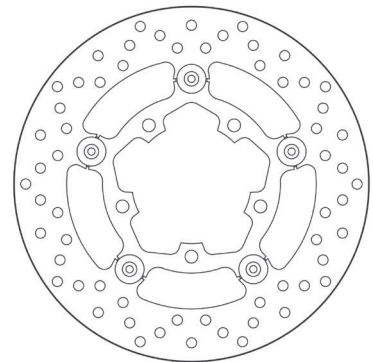

YAMAHA	Year	A/P
CYGNUS X 125 NXC	07->11	A

FIGURATO DISCHI FRENO CON APPLICAZIONI | BRAKE DISCS DRAWINGS AND APPLICATIONS | DESSINS DISQUES DE FREIN AVEC APPLICATIONS |  
DISEÑOS DISCOS DE FRENO CON RELACION | ZEICHNUNGEN VON BREMSSCHEIBEN MIT VERWENDUNGSLISTE



## DF4128

A

ØE:282 ØC:166 ØI:134 ØF:10,5 N°:5 SP:5

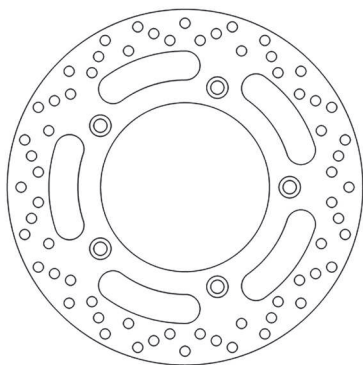

YAMAHA	Year	A/P
T MAX 530 XP	12->17	P
T MAX 530 XP ABS	15->16	P
T MAX DX 530 XP	17->19	P
T MAX SP 530 XP	15	P
T MAX SP 530 XP ABS	15->16	P
T MAX SX 530 XP	17->19	P

## DF4132

A

ØE:220 ØC:110 ØI:88 ØF:10,5 N°:5 SP:4

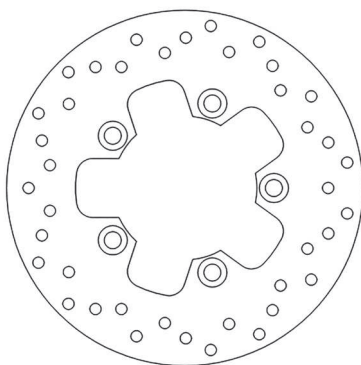

KYMCO	Year	A/P
LIKE 50 2T	09->	A
LIKE 50 4T	09->	A
LIKE 125	09->16	A
LIKE 200 i	09->16	A
LIKE 200 LX	12->	A

## DF4135

AF

ØE:260 ØC:80 ØI:58,1 ØF:10,6 N°:5 SP:4

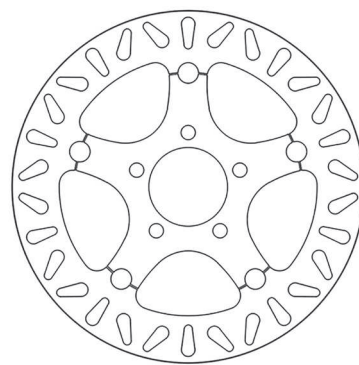

KYMCO	Year	A/P
DOWNTOWN 125 I	09->15	A
K-XCT 125 I	14->	A
XCITING 125 I	12->14	A
DOWNTOWN 200 I	10->15	A
DOWNTOWN 300 ABS	10->11	A
DOWNTOWN 300 I	09->11	A
DOWNTOWN 300 I ABS	10->11	A
K-XCT 300 I ABS	12->14	A
SUPER DINK 300	09->11	A

## DF4129

A

ØE:267 ØC:133 ØI:115 ØF:8,5 N°:5 SP:4

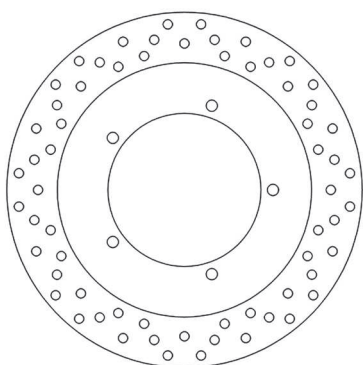

YAMAHA	Year	A/P
XENTER 125 HW	12->16	A
XENTER 150 HW	12->18	A

## DF4134

A

ØE:276 ØC:166 ØI:144,1 ØF:10,5 N°:6 SP:6

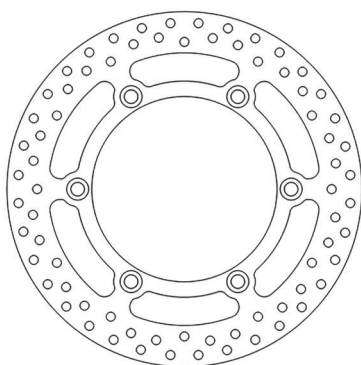

HONDA	Year	A/P
SILVER WING 400 FJS	09->	A
SW-T 400	09->	A
SW-T 400 ABS	09->	A
SILVER WING 600 FSC ABS	03->08	A
SW-T 600	11->18	A

## DF4131

A

ØE:200 ØC:110 ØI:90 ØF:10,5 N°:5 SP:4

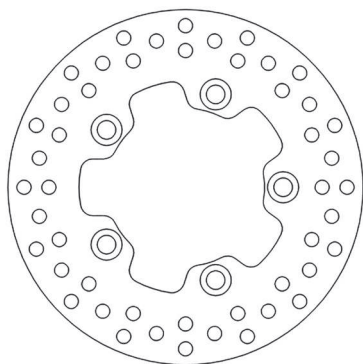

KYMCO	Year	A/P
G-DINK 125	12->	P
LIKE 125	09->16	P
LIKE 200 i	09->16	P
LIKE 200 LX	12->	P
G-DINK 300	12->	P

**DF5001**

**A**

ØE:276 ØC:166 ØI:144,1 ØF:10,5 N°:6 SP:5

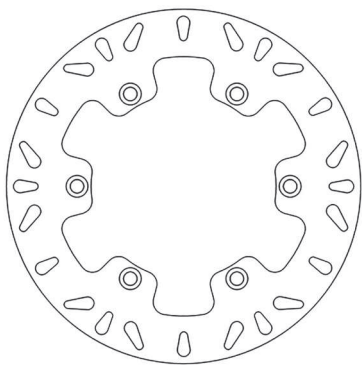

**DF5004**

**A**

ØE:256 ØC:136 ØI:115,1 ØF:10 N°:6 SP:5,5

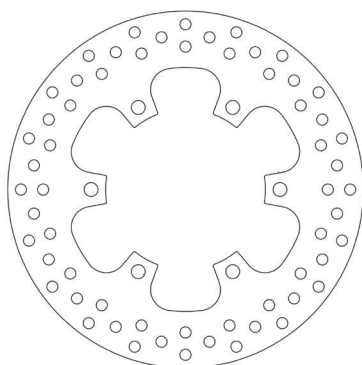

**...DF5005**

... segue HONDA	Year	A/P
SH 125 i	09->18	P
@ 150 NES	09->	P
SH 150 i	09->18	P
CB 250 TWO FIFTY	92->05	A
FORZA X 250 NSS	05->13	P
FORZA XE 250 NSS	05->13	P
FORZA 300 NSS ABS	18->18	P
SH 300 i ABS	15->18	P
CB 500	97->05	P
XL 600 V TRANSALP	91->96	P
XL 600 V TRANSALP	97->99	P
XL 650 V TRANSALP	00->07	P
XRV 650 AFRICA TWIN	88->90	P
CB 750 N SEVEN FIFTY	92->02	P
CB 900 HORNET	02->07	P

HONDA	Year	A/P
CBR 125 R	04->10	A
VFR 400 R	85->88	A
CBR 600 F	87->94	A
FX 650 VIGOR	99->03	A
SX 650 VIGOR	99->02	A
VFR 750 F INTERCEPTOR	86->87	A
XLV 750 R	83->88	A
VF 1000 F	84->86	A
VF 1000 R	84->86	A

TRIUMPH	Year	A/P
TRIDENT 749	91->98	P
DAYTONA 750	91->92	P
SPEED TRIPLE 885 (carb)	94->98	P
DAYTONA 885 900	93->98	P
DAYTONA 900 900 SUPER 3 750	94->96	P
SPRINT 885 900	94->97	P
SPRINT EXECUTIVE 885 900	98->	P
SPRINT SPORT 885 900	97->98	P
TRIDENT 885 900	91->98	P
TROPHY 885 900	91->03	P
DAYTONA 998 1000	91->92	P
DAYTONA 1180 1200	93->98	P
TROPHY 1180 1200	91->03	P

**DF5002**

**A**

ØE:220 ØC:102 ØI:86,1 ØF:6,3 N°:6 SP:5

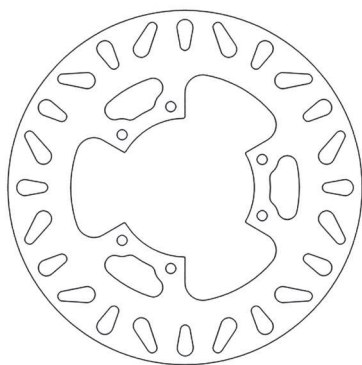

YAMAHA	Year	A/P
XT 600 4 VALVES	87->90	P
XT E 600	90->02	P
XT K 600	91->93	P
XT Z 600 TENERE	88->90	P
XT Z 660 TENERE	91->96	P

**DF5005**

**A**

ØE:240 ØC:125 ØI:105 ØF:10,5 N°:4 SP:5

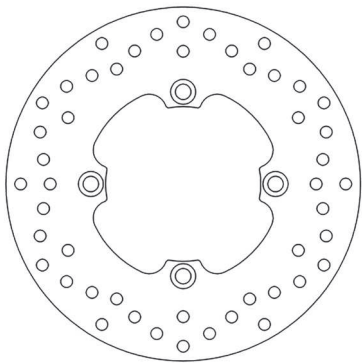

**DF5007**

**A**

ØE:230 ØC:102 ØI:86,1 ØF:6,2 N°:6 SP:3,5

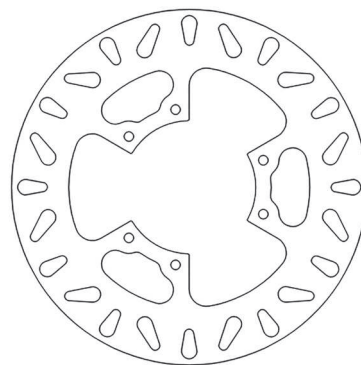

TM	Year	A/P
all models 125	->89	A
YAMAHA	Year	A/P
DT 125 R	88->03	A
DT-Z 125 TENERE	89->90	A
YZ 125	85->89	A
DT 200 R	88->91	A
YZ 250	85->89	A
TT 350	85->95	A
WR 500	92->93	A
TT 600	89->92	A
TT 600 N	85->88	A

**DF5003**

**A**

ØE:256 ØC:166 ØI:144,4 ØF:10,5 N°:4 SP:5

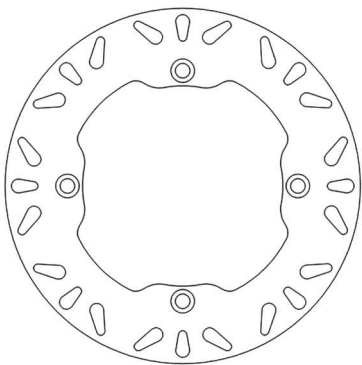

HONDA	Year	A/P
CBX 450 S	87->	A
XRV 750 R AFRICA TWIN	90->03	P
XL 1000 V VARADERO	99->02	P

BUELL	Year	A/P
BLAST 500	01->09	P
XB9R 984 FIREBOLT	02->10	P
XB9S 984 LIGHTNING	03->10	P
XB9SX 984 CITY X	05->10	P
CR 1125	09->10	P
R 1125	08->10	P
1200 all models	94->97	P
M2 1200 CYCLONE	98->02	P
RS 1200	93->	P
RS 1200 X 1	01->	P
S1 1200 LIGHTNING	98->02	P
S1 1200 WHITELIGHTNING	98->02	P
S3 1200 THUNDERBOLT	98->02	P
X1 1200 LIGHTNING	01->02	P
XB12R 1200 FIREBOLT	04->10	P
XB12S 1200 LIGHTNING	04->08	P
XB12SCG 1200 LIGHTNING	06->10	P
XB12SS 1200 LIGHTNING LONG	06->10	P
XB12TT 1200 SUPER TT	07->10	P
XB12X 1200 SUPER TT	06->10	P

HONDA	Year	A/P
@ 125 NES	09->	P
FORZA 125 NSS	15->19	P

FIGURATO DISCHI FRENO CON APPLICAZIONI | BRAKE DISCS DRAWINGS AND APPLICATIONS | DESSINS DISQUES DE FREIN AVEC APPLICATIONS | ZEICHNUNGEN VON BREMSSCHEIBEN MIT VERWENDUNGSLISTE



### DF5008

A

ØE:245 ØC:133 ØI:115,3 ØF:6,5 N°:6 SP:5

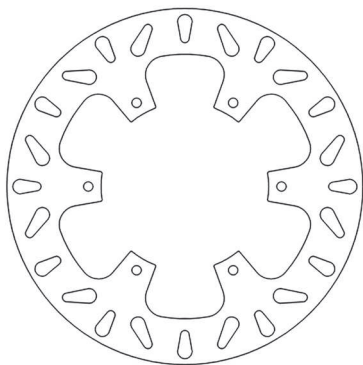

ITALJET	Year	A/P
JUPITER 250	00->	A
YAMAHA	Year	A/P
RD 500 LC	84->86	P
RD 500 YPVS LC	87->	P
XTZ 750 SUPER TENERE	89->95	P

### DF5009

A

ØE:220 ØC:125 ØI:105,5 ØF:10,5 N°:4 SP:5

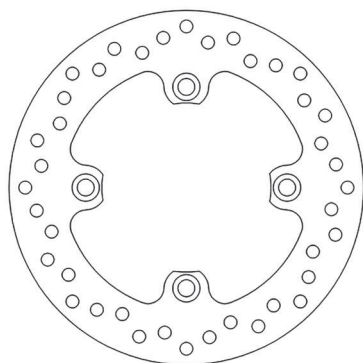

TRIUMPH	Year	A/P
BABY SPEED 600	01->02	P
DAYTONA 600 from VIN 210262	04->05	P
DAYTONA 600 up to VIN 210261	02->03	P
SPEED FOUR 600	03->06	P
TT 600	00->03	P
DAYTONA 650 FROM VIN 210262	04->06	P
DAYTONA 650 UP TO VIN 210261	02->03	P
DAYTONA 675 up to VIN 381274	06->08	P
DAYTONA TRIPLE 675	09->12	P
DAYTONA TRIPLE R 675	11->12	P
STREET TRIPLE 675	08->12	P
STREET TRIPLE R 675	09->12	P
SPEED TRIPLE 885 EFI T509 up to 141871	97->98	P
DAYTONA 955 T595	97->00	P
DAYTONA i 955	03->06	P
DAYTONA i 955 BIBRACCIO	01->02	P
DAYTONA i 955 CENTENNIAL	02->04	P
SPEED TRIPLE 955 T595 up to 141871	99->01	P
SPEED TRIPLE i 955 i VIN 141872 to 210444	02->06	P
SPEED TRIPLE 1050	05->10	P

### DF5010

A

ØE:240 ØC:142 ØI:121,2 ØF:10,5 N°:4 SP:5

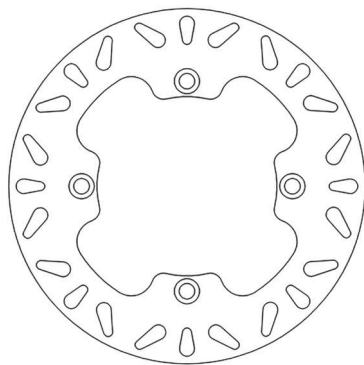

SUZUKI	Year	A/P
DR 600 R	86->89	A
DR 600 R DAKAR-DJEBEL	87->88	A
DR 600 S	86->88	A

### DF5011

A

ØE:240 ØC:134,6 ØI:118,1 ØF:10,5 N°:4 SP:4

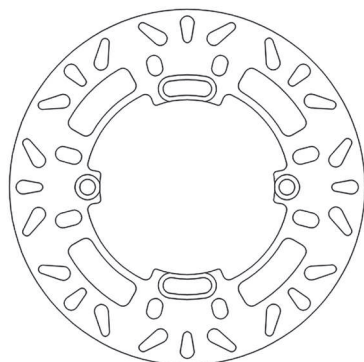

HONDA	Year	A/P
CR 125 R	89->94	A
XLR 125	93->	A
CR 250 R	89->94	A
CRM 250 R	91->96	A
XL 350 R	85->	A
XR 350 R	83->84	A
CR 500 R	90->94	A

### DF5013

A

ØE:220 ØC:140 ØI:121,1 ØF:10,5 N°:4 SP:5

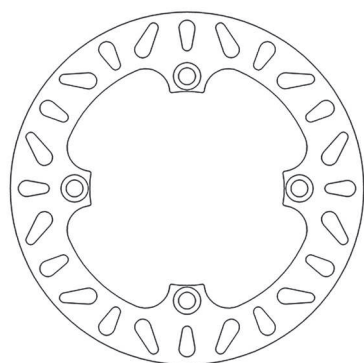

HONDA	Year	A/P
CR 125 R	89->96	P
AX 1 250	89->94	P
CR 250 R	89->96	P
CR 500 R	90->97	P

### DF5014

A

ØE:245 ØC:133 ØI:115 ØF:8,5 N°:6 SP:5

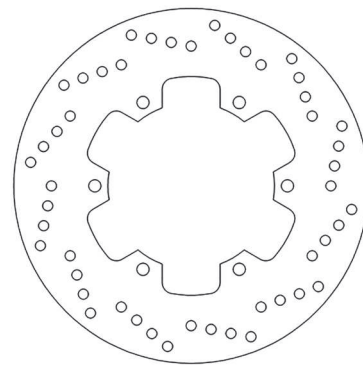

YAMAHA	Year	A/P
SRX 400	90->96	P
XJR 400	95->96	P
XJR 400	97->99	P
FZR 600	89->95	P
FZR 600 R	94->95	P
FZS 600 FAZER	98->99	P
FZS 600 SP FAZER	00->03	P
SRX 600	85->91	P
XJ 600 N	98->03	P
XJ S 600 DIVERSION	92->03	P
YZ-F 600 R THUNDER CAT	96->04	P
XT R 660	04->12	P
XT X 660	04->11	P
XT Z 660 TENERE	08->15	P
YZ-F 750 R7 (OW02) road version	99->00	P
YZ-F 750 RR-SP	93->98	P
TDM 850	91->01	P
TRX 850	96->97	P
TDM 900	02->12	P
YZ-F 1000 R THUNDER ACE	96->01	P
YZ-F 1000 R1	98->01	P

### DF5016

A

ØE:276 ØC:166 ØI:144,2 ØF:10,6 N°:4 SP:4

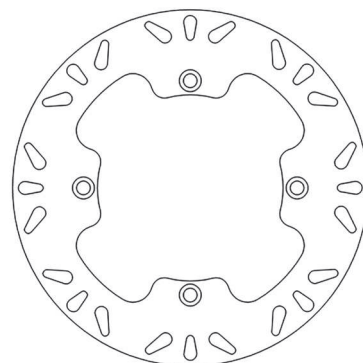

HONDA	Year	A/P
XRV 750 R AFRICATWIN	90->03	A
TGB	Year	A/P
X-MOTION 300	10->	A

**DF5017**

A

ØE:260 ØC:135 ØI:120,1 ØF:6,3 N°:6 SP:4

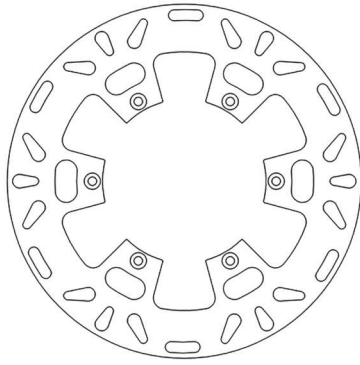

**DF5019**

A

ØE:220 ØC:125 ØI:108,2 ØF:8,6 N°:4 SP:6

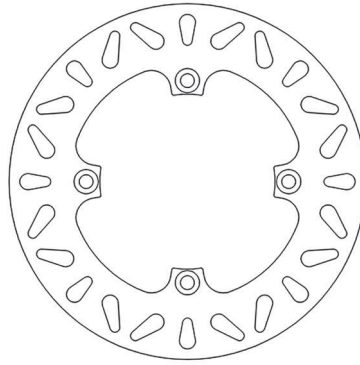

**DF5021**

A

ØE:220 ØC:133 ØI:115,1 ØF:6,5 N°:6 SP:5

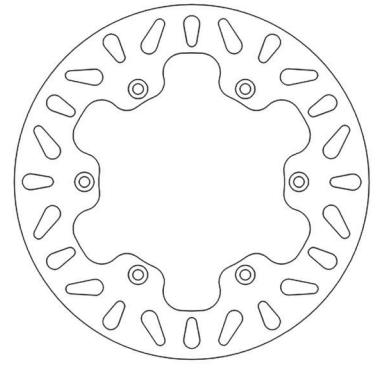

HUSQVARNA	Year	A/P
CR 125	91->95	A
WR 250	91->97	A
TE 350	96->13	A
TE 410	95->99	A
TE 610	91->97	A

DUCATI	Year	A/P
748	02	P
748 BIPOSTO	01	P
748 BIPOSTO - SP	95->01	P
748 R	00->02	P
748 S	00->02	P
748 SP	95->97	P
748 SPS	98->99	P
MH 900	01->02	P
916 BIPOSTO SENNA	94->98	P
916 SP	94->96	P
996	99->01	P
996 R	01	P
996 S	01	P
998 R - S	02->03	P
998 S	02->06	P
998 S (pinza radiale)	02->03	P

TM	Year	A/P
all models 125	->89	P

YAMAHA	Year	A/P
DT 125 R	88->03	P
TDR 125 (Italia)	89->93	P
TDR 125 R LIGHTBURNER	93->94	P
WR 125	91->97	P
YZ 125	88->97	P
WR 200	92->94	P
TT R 250	93->00	P
WR 250 Z	91->98	P
YZ 250	88->97	P
YZ 360	89->	P
YZ 360 RALLY	90->93	P
WR 500	92->93	P
TT 600 K	93->96	P
TT E 600	93->01	P
TT R 600	98->02	P
TT R 600 E	04->07	P

**DF5018**

A

AP

ØE:220 ØC:130 ØI:112,1 ØF:9,7 N°:6 SP:5

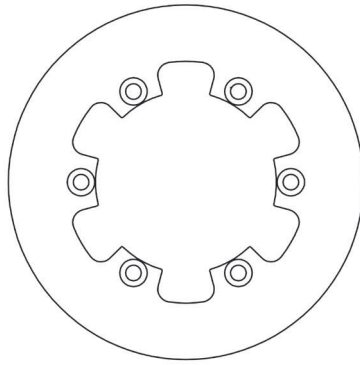
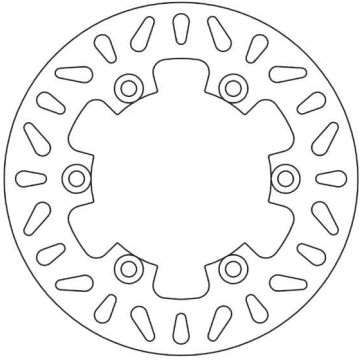

HUSQVARNA	Year	A/P
CR 125	91->95	P
WR 125	91->97	P
WR 250	91->97	P
TE 350	90->13	P
TE 410	95->99	P
TC 610	91->97	P
TE 610	91->97	P

**DF5020**

A

ØE:240 ØC:140 ØI:121,1 ØF:10 N°:4 SP:4

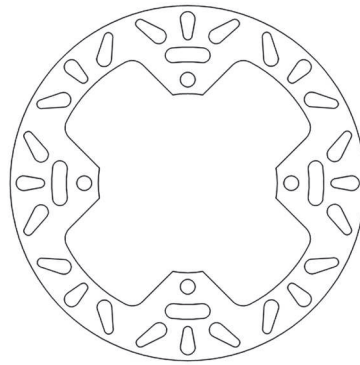

HONDA	Year	A/P
CR 125 R	97->01	P
CR 125 SUPERMOTARD	00->	P
CR 250 R	97->01	P
CR 250 SUPERMOTARD	98->01	P
CR 500 R	98->01	P

**DF5022**

A

ØE:220 ØC:110 ØI:89,1 ØF:10,5 N°:5 SP:5

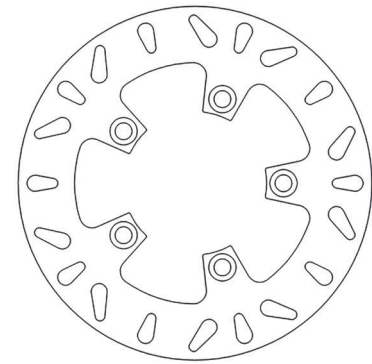

SUZUKI	Year	A/P
GSX-R 600	96->19	P
SV 650	03->18	P
SV 650 S	03->18	P
GSX-R 750	00->19	P
GSX-R 750 T SRAD	96->99	P
GSX-R 1000	01->16	P
SV 1000 FAIRED	03->07	P
SV 1000 NAKED	03->07	P
TL 1000 R	98->03	P
TL 1000 S	97->02	P
GSX-R 1100	86->88	P

FIGURATO DISCHI FRENO CON APPLICAZIONI | BRAKE DISCS DRAWINGS AND APPLICATIONS | DESSINS DISQUES DE FREIN AVEC APPLICATIONS |  
DISEÑOS DISCOS DE FRENO CON RELACION | ZEICHNUNGEN VON BREMSSCHEIBEN MIT VERWENDUNGSLISTE



**DF5024**
**A | AP | OE**

ØE:220 ØC:125 ØI:110 ØF:6,5 N°:6 SP:4

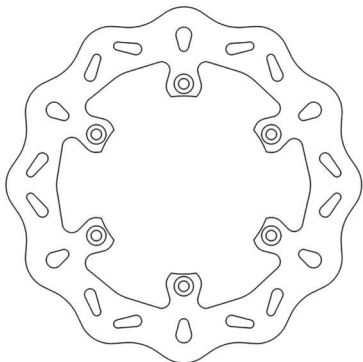
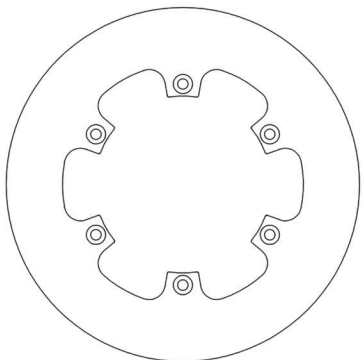
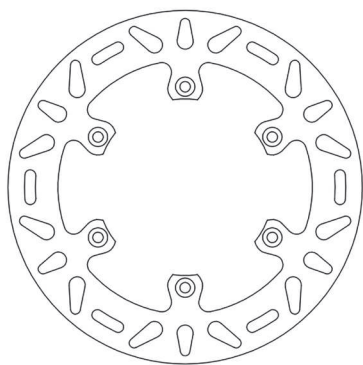

GAS GAS	Year	A/P
MC 80	95->02	P
EC 125 2T RACING	13->15	P
EC 125 MX	02->07	P
EC 125 SM	02->07	P
EC 125 SYXDAYS	10->11	P
MC 125	96->09	P
EC 200 2T	99->11	P
EC 200 2T R	18->19	P
EC 200 2T RACING	13->17	P
EC 200 MX	02->10	P
EC 200 SM	02->07	P
EC 200 SYXDAYS	10	P
HOBBY 200	07	P
EC 250 2T	97->17	P
EC 250 2T R	18->19	P
EC 250 2T RACING	13->17	P
EC 250 MX	01->07	P
EC 250 SM	02->07	P
EC 250 SYXDAYS	10	P
EC F 250 4T	10->15	P
ENDURCROSS 250	95->	P
JT 250 CONTACT	94->	P
MC 250	97->09	P
SM 250	02->	P
T 250 CONTACT	93	P
EC 300 2T	98->17	P
EC 300 2T R	18->19	P
EC 300 2T RACING	13->17	P

... segue GAS GAS	Year	A/P
EC 300 MC	02->10	P
EC 300 SM	02->07	P
EC 300 SYXDAYS	10	P
EC F 300 4T	13->15	P
MC 300	96->09	P
EC 400 FSE	03->04	P
PAMPERA 400	06->07	P
EC 450 FSE	05->09	P
EC 450 FSR	05->09	P
EC F 450 4T	13->15	P
HUSABERG	Year	A/P
FE 390	10->13	P
FC 400	99->02	P
FE 400 S - E	98->03	P
FC 450	98->08	P
FE 450	09->13	P
FE 450 E	04->08	P
FX 450	03->08	P
FC 470 E	01->02	P
FX 470 E	01->02	P
FC 501	98->01	P
FE 501 S - E	98->04	P
FC 550	01->05	P
FE 550 E	04->08	P
FE 570	09->13	P
FC 600 SUPERMOTARD	98->01	P
FE 600 S - E - R	98->02	P
FE 650 E	01->08	P
FX 650 E	01->05	P
HUSQVARNA	Year	A/P
TC 125	14->20	P
TE 125	14->16	P
TE 125 4T	11->13	P
TX 125	17->20	P
FC 250	14->20	P
FE 250	13->20	P
TC 250	14->20	P
TE 250	14->17	P
TE 250 i	18->20	P
TC 300	14->17	P
TE 300	14->17	P
TE 300 i	18->20	P
TX 300	19	P
TX 300 i	20	P
FC 350	14->20	P
FE 350	14->20	P
FX 350	17->20	P
FC 450	14->20	P
FE 450	14->20	P
FR 450 RALLY	16->20	P
FX 450	19->20	P
TE 450	14	P
FE 501	14->20	P
KTM	Year	A/P
EXC 125	90->15	P
EXC 125 SIX DAYS	01->16	P
EXC/EGS 125	94->97	P
EXE 125	00->11	P
SX 125	96->20	P
SXS 125	01->10	P
SX 144	07->10	P
SX 150	08->20	P
XC 150	11->18	P
EGS 200	98->99	P
EXC 200	04->16	P
SX 200	03->07	P
XC-W 200	11->16	P
EGS 250	94->99	P
EXC 250	94->17	P
EXC 250 SIX DAYS (2T)	05->17	P
EXC 250 SIX DAYS TPI (2T)	18->20	P
EXC 250 TPI (2T)	18->20	P
EXC RACING 250 (4T)	00->06	P
EXC-F 250	06->20	P
EXC-F 250 SIX DAYS	07->20	P

... segue KTM	Year	A/P
MX 250	92->13	P
SX 250	94->20	P
SX-F 250	05->20	P
SXS 250	01->03	P
SXS-F 250	06->08	P
XC 250 (2T)	94->17	P
XC 250 TPI (2T)	18->19	P
XC-F 250	11->20	P
XC-W 250 (2T)	11->17	P
XC-W 250 TPI (2T)	18->19	P
XCF-W 250	12->17	P
EXC 300	94->16	P
EXC 300 EGS	93->99	P
EXC 300 SIX DAYS (2T)	05->17	P
EXC 300 SIX DAYS TPI (2T)	18->20	P
EXC 300 TPI (2T)	18->20	P
XC 300 (2T)	11->19	P
XC 300 TPI (2T)	20	P
XC-W 300 (2T)	14->18	P
XC-W 300 SIX DAYS (2T)	18	P
XC-W 300 TPI (2T)	19->20	P
XC-W 300 TPI SIX DAYS (2T)	19->20	P
EXC-F 350	12->20	P
EXC-F 350 SIX DAYS	12->20	P
SX-F 350	11->20	P
XC-F 350	11->20	P
XCF-W 350	11->20	P
EXC 360	96->97	P
SX 360	96->97	P
EXC 380	98->02	P
MXC 380	98->02	P
SX 380	98->02	P
EXC 400	00->04	P
EXC RACING 400	00->07	P
EXC-G RACING 400	04->08	P
MXC 400	00->02	P
SX 400	00->02	P
SX RACING 400	02	P
SXC 400	99->00	P
EXC RACING 450	03->07	P
EXC-F 450	17->20	P
EXC-F 450 SIX DAYS	17->20	P
EXC-R 450	08->16	P
EXC-R RACING 450 (USA)	11	P
MXC 450	04->06	P
SMR 450	07->13	P
SMR 450 (FTE caliper)	04->06	P
SX 450	03->06	P
SX-F 450	07->20	P
XC 450	06->07	P
XC-F 450	14->20	P
XC-W 450	08->16	P
XC-W 450 SIX DAYS (USA)	11	P
EXC 500 4T	12->16	P
EXC-F 500	17->20	P
EXC-F 500 SIX DAYS	17->20	P
EXC/MX 500	92->95	P
LC4 EXC/EGS 500	92	P
XC-W 500	12->16	P
XCF-W 500	20	P
SX-F 505	07->09	P
XC-F 505	07->09	P
EXC RACING 520	00->02	P
MXC 520	00->02	P
SX 520	00->02	P
EXC RACING 525	03->07	P
MXC 525	03->05	P
SX 525	03->07	P
XC 525	06->07	P
EXC-R 530	08->11	P
EXC-R RACING 530 (USA)	11	P
XC-W 530	08->11	P
XC-W 530 SIX DAYS	11	P
XC-W 530 SIX DAYS (USA)	11	P
LC4 540 SXC	98->00	P

...DF5024		
... segue KTM	Year	A/P
SXS 540 RACING	02	P
SMR 560	06->07	P
LC4 600	90->93	P
LC4 620 ADVENTURE	97->98	P
LC4 620 DUKE	94->97	P
LC4 620 RXC	96->97	P
LC4 620 SC	98->04	P
LC4 620 SC SM	00->	P
LC4 620 SX	95->99	P
LC4 625 SXC	03->07	P
LC4 640 ADVENTURE	98->07	P
LC4 640 DUKE	98	P
LC4 640 DUKE II	99->06	P
LC4 640 SUPERMOTO	03->06	P
LC4 E 640 HARD ENDURO	98->06	P
LC4-E 640 SUPERMOTO	99->06	P
LC4 660 SM FACTORY REPLICA	02->03	P
LC4-E 660 RALLYE	01->	P
SMC 660 SUPERMOTO	03->06	P

DF5025		
ØE:220	ØC:143,5	ØI:122
ØF:10,5	N°:6	SP:5

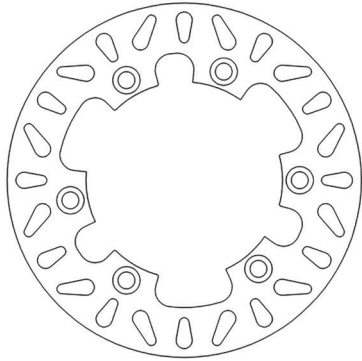

HONDA		
Year	A/P	
CR 125 R	85->88	P
CR 500 R	87->89	P

DF5026		
ØE:245	ØC:134	ØI:118,1
ØF:6,8	N°:6	SP:4

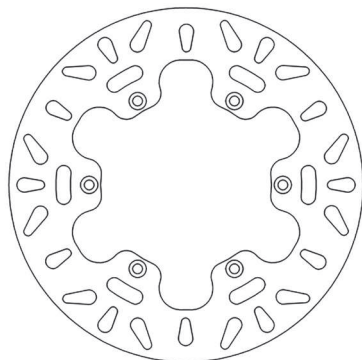

YAMAHA		
Year	A/P	
WR 125	98->00	A
YZ 125	98->00	A
WR 250	98->00	A
YZ 250	98->00	A
WR F 426	00	A

DF5027		
ØE:220	ØC:133,8	ØI:118
ØF:6,5	N°:6	SP:4

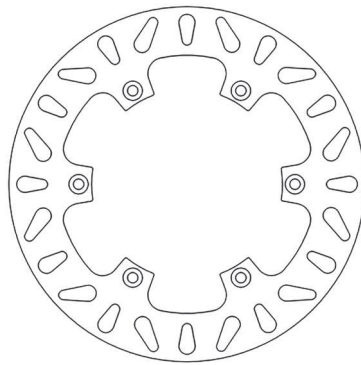

SUZUKI		
Year	A/P	
RM 125	88->00	P
RM 250	89->00	P
RMX 250	89->99	P
DR Z 400 E	00->09	P
DR Z 400 S	00->08	P

DF5028		
ØE:251	ØC:156	ØI:135
ØF:10,5	N°:6	SP:6

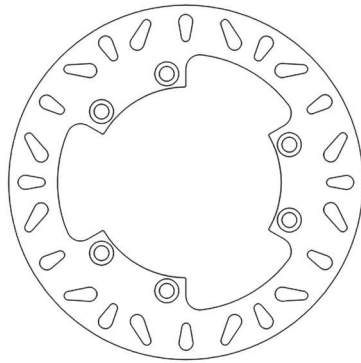

SUZUKI		
Year	A/P	
DR 600 R	86->89	P
DR 600 R DAKAR-DJEBEL	87->88	P
DR 600 S	86->88	P
DR 650 R	90->95	P
DR 650 RS-R DAKAR	90	P
DR 650 RS-RSE-DJEBEL-DAKAR	91->95	P
DR 750 S BIG	89	P
DR 800 BIG all models	91->93	P
DR 800 BIG S - SU	90	P
DR 800 Z	88->89	P

DF5029		
ØE:240	ØC:134	ØI:118
ØF:6,3	N°:6	SP:4

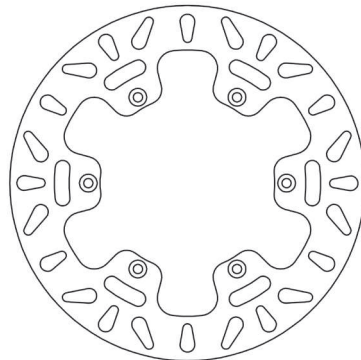

SUZUKI		
Year	A/P	
RM 125	01->12	P
RM 250	01->08	P
DR Z 400 SM	05->09	P

DF5030		
ØE:240	ØC:134	ØI:115
ØF:6,3	N°:6	SP:4

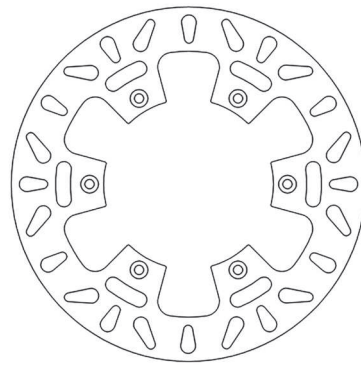

YAMAHA		
Year	A/P	
YZ 125	98->00	P
WR 250	98->00	P
YZ 250	98->00	P
YZ-F 400	98->99	P

DF5034		
ØE:220	ØC:125	ØI:105,5
ØF:6,3	N°:4	SP:5

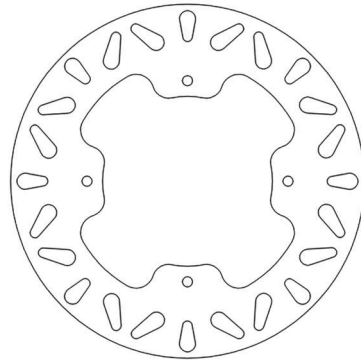

HONDA		
Year	A/P	
XLR 250 R BAJA	88->91	P
FMX 650	05->08	P
NX 650 DOMINATOR	93->04	P
SLR 650	97->98	P
SX 650 VIGOR	99->02	P

DF5036		
ØE:220	ØC:130	ØI:112,2
ØF:9,5	N°:4	SP:4

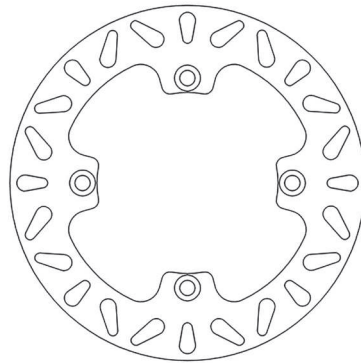

HUSQVARNA		
Year	A/P	
CR 125	96->03	P
WR 125	98->03	P
WRE 125	95->04	P
WRE 125 DUAL	95->03	P
CR 250	96->03	P
TE 250	02->03	P
WR 250	98->03	P





...DF5036		
... segue HUSQVARNA	Year	A/P
WR 360	00->01	P
TE 410	00->01	P
TE 610 E	00->03	P

DF5037		A
ØE:220	ØC:142,1	ØI:118,1 ØF:8,5 N°:4 SP:4

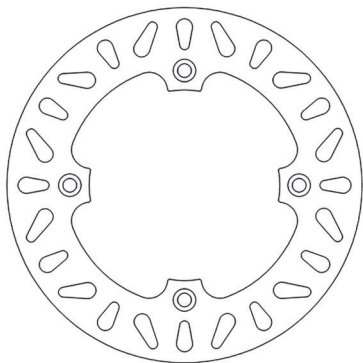

SUZUKI	Year	A/P
TS 125	89->96	P
DR 250 S	90->95	P
DR 350	90->99	P

DF5038		A
ØE:240	ØC:133	ØI:115,1 ØF:6,5 N°:6 SP:4

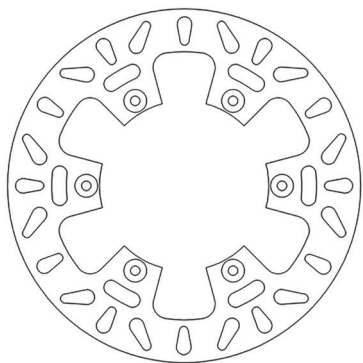

YAMAHA	Year	A/P
WR 125	98->02	P
YZ 125	01	P
WR F 250	01	P
YZ 250	01	P
WR F 400	98->00	P
WR F 426	00->02	P
YZ-F 426	00	P

DF5039		AF
ØE:260	ØC:134	ØI:118,1 ØF:6,6 N°:6 SP:3

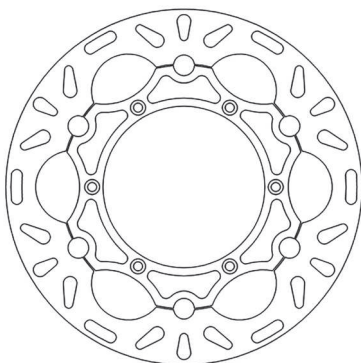

SUZUKI	Year	A/P
RM 125	96->12	A
RM 250	97->08	A
RMX 250	89->99	A
DR Z 400 E	00->09	A
DR Z 400 S	00->08	A

YAMAHA	Year	A/P
WR 125	01->02	A
YZ 125	01->16	A
WR F 250	01->07	A
YZ 250	01->16	A
YZ-F 250	01->15	A
WR F 400	98->02	A
YZ-F 400	98->99	A
WR F 426	00->02	A
YZ-F 426	00->02	A
WR F 450	03->15	A
YZ-F 450	03->15	A

DF5040		AF	OE
ØE:270	ØC:133,9	ØI:118,1 ØF:6,6 N°:6 SP:3	

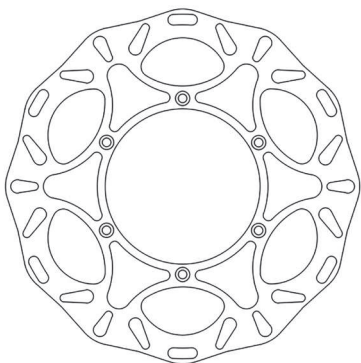
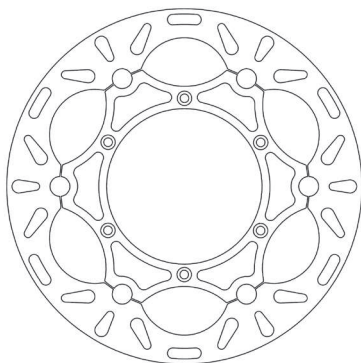

SUZUKI	Year	A/P
RM 125	88->12	A
RM 250	89->08	A
RMX 250	89->99	A
DR Z 400 E	00->09	A
DR Z 400 S	00->08	A

...DF5040		
YAMAHA	Year	A/P
WR 125	01->02	A
YZ 125	01->16	A
YZ 125	17->20	A
WR F 250	01->16	A
WR F 250	17->20	A
YZ 250	01->16	A
YZ 250	17->20	A
YZ-F 250	01->15	A
YZ-F 250	16->20	A
WR F 400	98->02	A
YZ-F 400	98->99	A
WR F 426	00->02	A
YZ-F 426	00->02	A
WR F 450	03->15	A
WR F 450	16->19	A
YZ-F 450	03->15	A
YZ-F 450	16->19	A

DF5041		A	AF	OE
ØE:250	ØC:134	ØI:118,2 ØF:6,6 N°:6 SP:3		

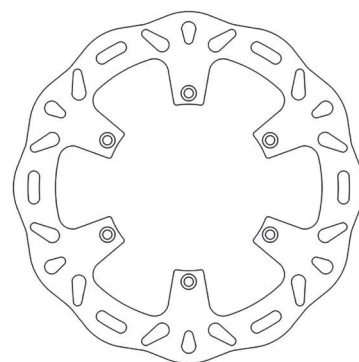
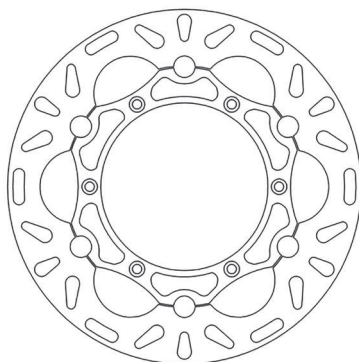
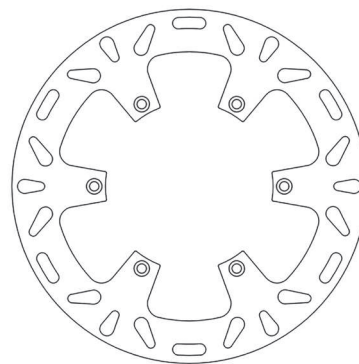

SUZUKI	Year	A/P
RM 125	88->12	A
RM 250	89->08	A
RMX 250	89->99	A
DR Z 400 E	00->09	A
DR Z 400 S	00->08	A

YAMAHA	Year	A/P
WR 125	01->02	A

...DF5041		
... segue YAMAHA	Year	A/P
YZ 125	01->16	A
WR F 250	01->16	A
YZ 250	01->16	A
YZ-F 250	01->15	A
WR F 400	98->02	A
YZ-F 400	98->99	A
WR F 426	01->02	A
YZ-F 426	00->02	A
WR F 450	03->15	A
YZ-F 450	03->15	A

DF5042		AF	OE
ØE:260	ØC:125,4	ØI:109,1	ØF:6,8 N°:6 SP:3

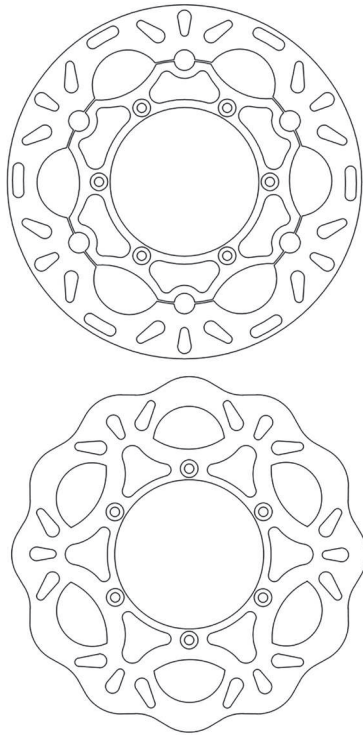

GAS GAS	Year	A/P
MC 80	95->02	A
EC 125 2T RACING	13->15	A
EC 125 MX	02->07	A
EC 125 SM	02->07	A
EC 125 SYXDAYS	10->11	A
MC 125	96->09	A
EC 200 2T	99->11	A
EC 200 2T R	18->19	A
EC 200 2T RACING	13->17	A
EC 200 MX	02->10	A
EC 200 SM	02->07	A
EC 200 SYXDAYS	10	A
HOBBY 200	07	A
EC 250 2T	97->17	A
EC 250 2T R	18->19	A
EC 250 2T RACING	13->17	A
EC 250 MX	01->07	A
EC 250 SM	02->07	A
EC 250 SYXDAYS	10	A
EC F 250 4T	10->15	A
ENDURCROSS 250	95->	A
JT 250 CONTACT	94->	A
MC 250	97->09	A
SM 250	02->	A
T25 250 CONTACT	93	A
EC 300 2T	98->17	A
EC 300 2T R	18->19	A
EC 300 2T RACING	13->17	A

...DF5042		
... segue GAS GAS	Year	A/P
EC 300 MC	02->10	A
EC 300 SYXDAYS	10	A
EC F 300 4T	13->15	A
MC 300	96->09	A
EC 400 FSE	03->04	A
PAMPERA 400	06->07	A
EC 450 FSE	05->09	A
EC 450 FSR	05->09	A
EC F 450 4T	13->15	A

DF5044		A	AF
ØE:250	ØC:116	ØI:100,3	ØF:6,5 N°:4 SP:3

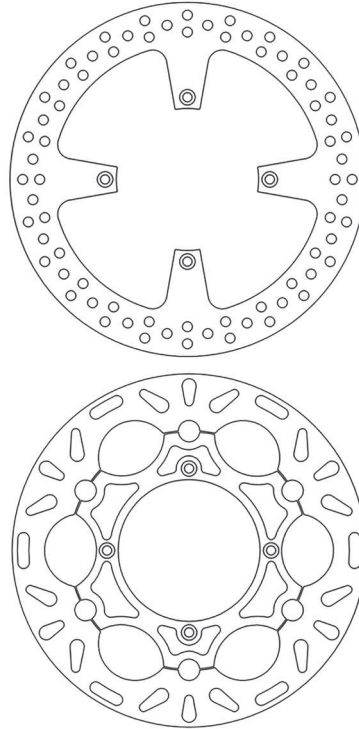

KAWASAKI	Year	A/P
KX 125	88->02	A
KDX 250	91->93	A
KDX 250 ESTRELLA	92->	A
KX 250	87->02	A
KLX 300	97->06	A
KX 500	87->04	A
KLX 650 R	93->97	A

DF5045		A	AF
ØE:270	ØC:117	ØI:101,3	ØF:6,5 N°:6 SP:3

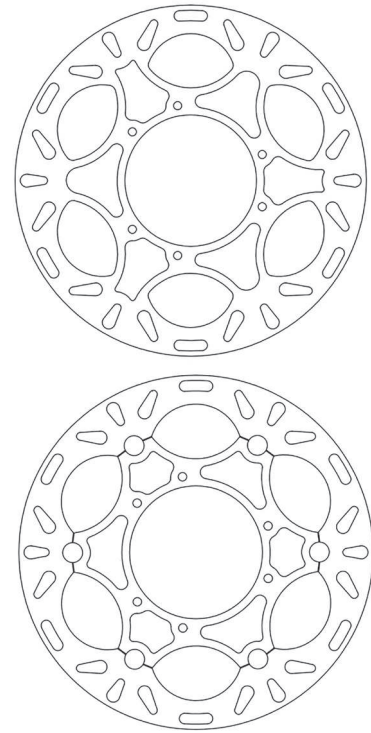

HONDA	Year	A/P
CR 125 R	95->07	A
CRE 125	02->07	A
CR 250 R	95->10	A
CRE 250	02->07	A
CRE 250 IE	07->08	A
CRF 250 R - E	04->14	A
CRF 250 X	04->17	A
CRE 290 IE	07->08	A
CRF 300 X	08->12	A
CRF 450 R - E	02->14	A
CRF 450 X	05->14	A
CR 500 R	95->01	A

DF5046		AF
ØE:270	ØC:116	ØI:100,4 ØF:6,5 N°:4 SP:3

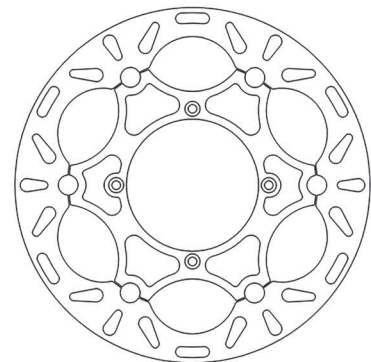

KAWASAKI	Year	A/P
KX 125	94->02	A
KX 250	94->02	A
KX 500	94->04	A





**DF5047**
**A | AF | OE**

ØE:240 ØC:117 ØI:101,1 ØF:6,3 N°:6 SP:3

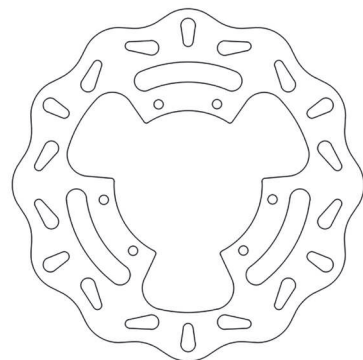
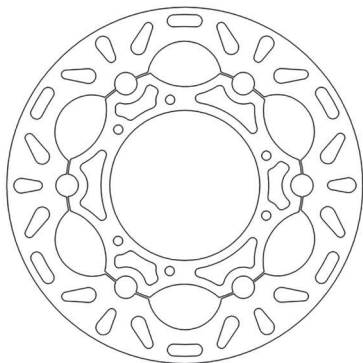
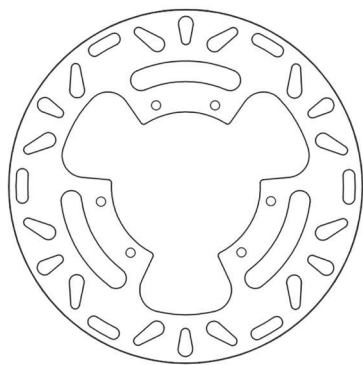

HONDA	Year	A/P
CR 125 R	95->07	A
CRE 125	02->07	A
CRF 230	04->09	A
CR 250 R	95->10	A
CRE 250	02->07	A
CRE 250 IE	07->08	A
CRF 250 R - E	04->14	A
CRF 250 X	04->17	A
CRE 290 IE	07->08	A
CRF 300 X	08->12	A
CRF 450 R - E	02->14	A
CRF 450 X	05->14	A
CR 500 R	95->01	A

**DF5048**
**A | AF | OE**

ØE:260 ØC:143 ØI:127,1 ØF:6,5 N°:6 SP:3

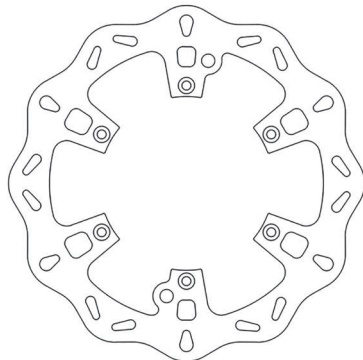
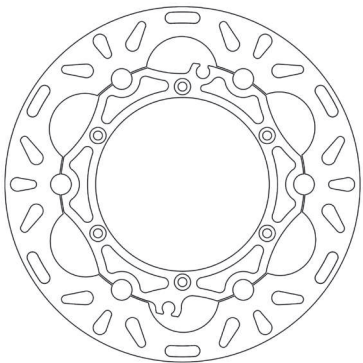
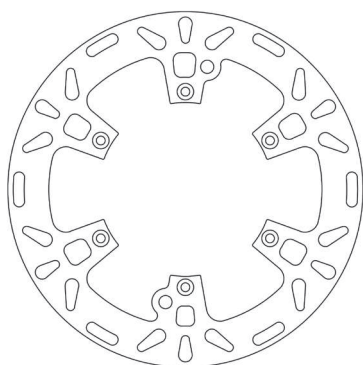

BETA	Year	A/P
RR 250	13	A
RR 250 2T ENDURO	14->17	A
RR 300 2T ENDURO	13->17	A
RR 350 4T ENDURO	13->17	A
RR 390 4T ENDURO	15->17	A
RR 400 4T ENDURO	13->14	A
RR 430 4T ENDURO	15->17	A
RR 450 4T ENDURO	13->15	A
RR 450 CROSS	13->14	A
RR 480 4T ENDURO	15->17	A
RR 498 4T ENDURO	12->14	A
RR 498 4T FACTORY	12	A

HUSABERG	Year	A/P
FE 390	10->13	A
FC 400	99->02	A
FE 400 S - E	98->03	A
FC 450	98->08	A
FE 450	09->13	A
FE 450 E	04->08	A
FX 450	03->08	A
FC 470 E	01->02	A
FX 470 E	01->02	A
FC 501	98->01	A
FE 501 S - E	98->04	A
FC 550	01->05	A
FE 550 E	04->08	A
FE 570	09->13	A
FC 600 SUPERMOTARD	98->01	A

**...DF5048**

... segue HUSABERG	Year	A/P
FE 600 S - E - R	98->02	A
FE 650 E	01->08	A
FX 650 E	01->05	A
HUSQVARNA	Year	A/P
TC 125	14->20	A
TE 125	14->16	A
TE 125 4T	11->13	A
TX 125	17->20	A
FC 250	14->20	A
FE 250	13->20	A
TC 250	14->20	A
TE 250	14->17	A
TE 250 i	18->20	A
TC 300	14->17	A
TE 300	14->17	A
TE 300 i	18->20	A
TX 300	19	A
TX 300 i	20	A
FC 350	14->20	A
FE 350	14->20	A
FX 350	17->20	A
FC 450	14->20	A
FE 450	14->20	A
FX 450	19->20	A
TE 450	14	A
FE 501	14->20	A
KTM	Year	A/P
EXC 125	90->15	A
EXC 125 SIX DAYS	01->16	A
EXC/EGS 125	94->97	A
EXE 125	00->11	A
SX 125	96->20	A
SXS 125	01->10	A
SX 144	07->10	A
SX 150	08->20	A
XC 150	11->18	A
EGS 200	98->99	A
EXC 200	04->16	A
SX 200	03->07	A
XC-W 200	11->16	A
EGS 250	94->99	A
EXC 250	94->17	A
EXC 250 SIX DAYS (2T)	05->17	A
EXC 250 SIX DAYS TPI (2T)	18->20	A
EXC 250 TPI (2T)	18->20	A
EXC RACING 250 (4T)	00->06	A
EXC-F 250	06->20	A
EXC-F 250 SIX DAYS	07->20	A
MX 250	92->13	A
SX 250	94->20	A
SX-F 250	05->20	A
SXS 250	01->03	A
SXS-F 250	06->08	A
XC 250 (2T)	94->17	A
XC 250 TPI (2T)	18->19	A
XC-F 250	11->20	A
XC-W 250 (2T)	11->17	A
XC-W 250 TPI (2T)	18->19	A
XCF-W 250	12->17	A
EXC 300	94->16	A
EXC 300 EGS	93->99	A
EXC 300 SIX DAYS (2T)	05->17	A
EXC 300 SIX DAYS TPI (2T)	18->20	A
EXC 300 TPI (2T)	18->20	A
XC 300 (2T)	11->19	A
XC 300 TPI (2T)	20	A
XC-W 300 (2T)	14->18	A
XC-W 300 SIX DAYS (2T)	18	A
XC-W 300 TPI (2T)	19->20	A
XC-W 300 TPI SIX DAYS (2T)	19->20	A
EXC-F 350	12->20	A
EXC-F 350 SIX DAYS	12->20	A
SX-F 350	11->20	A
XC-F 350	11->20	A
XCF-W 350	11->20	A

...DF5048	
... segue <b>KTM</b>	Year A/P
EXC 360	96->97 A
SX 360	96->97 A
EXC 380	98->02 A
MXC 380	98->02 A
SX 380	98->02 A
EXC 400	00->04 A
EXC RACING 400	00->07 A
EXC-G RACING 400	04->08 A
MXC 400	00->02 A
SX 400	00->02 A
SX RACING 400	02 A
SXC 400	99->00 A
EXC RACING 450	03->07 A
EXC-F 450	17->20 A
EXC-F 450 SIX DAYS	17->20 A
EXC-R 450	08->16 A
EXC-R RACING 450 (USA)	11 A
MXC 450	04->06 A
SX 450	03->06 A
SX-F 450	07->20 A
XC 450	06->07 A
XC-F 450	14->20 A
XC-W 450	08->16 A
XC-W 450 SIX DAYS (USA)	11 A
EXC 500 4T	12->16 A
EXC-F 500	17->20 A
EXC-F 500 SIX DAYS	17->20 A
EXC/MX 500	92->95 A
LC4 EXC/EGS 500	92 A
XC-W 500	12->16 A
XCF-W 500	20 A
SX-F 505	07->09 A
XC-F 505	07->09 A
EXC RACING 520	00->02 A
MXC 520	00->02 A
SX 520	00->02 A
EXC RACING 525	03->07 A
MXC 525	03->05 A
SX 525	03->07 A
XC 525	06->07 A
EXC-R 530	08->11 A
EXC-R RACING 530 (USA)	11 A
XC-W 530	08->11 A
XC-W 530 SIX DAYS	11 A
XC-W 530 SIX DAYS (USA)	11 A
LC4 540 SXC	98->00 A
SXS 540 RACING	02 A
LC4 600	90->93 A
LC4 620 RXC	96->97 A
LC4 620 SC	98->04 A
LC4 620 SC SM	00-> A
LC4 620 SX	95->99 A
LC4 625 SXC	03->07 A

**DF5049** | **A** | **AP** | **OE**  
 ØE:245 ØC:133 ØI:115,2 ØF:6,6 N°:6 SP:4

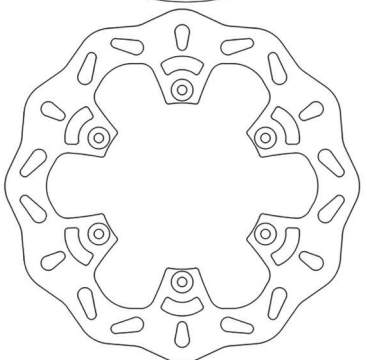
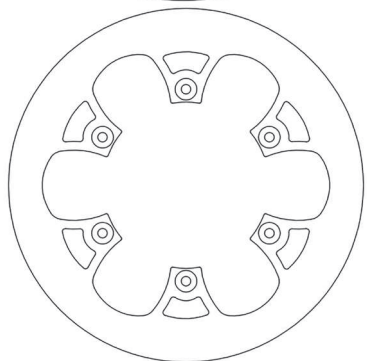
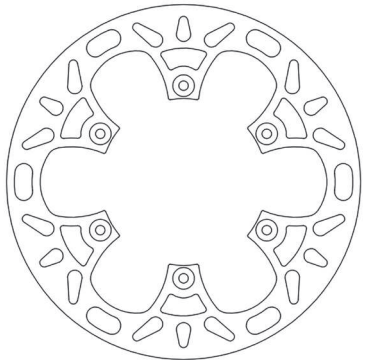

**YAMAHA**

	Year	A/P
YZ 125	02->20	P
WR F 250	02->20	P
YZ 250	02->20	P
YZ-F 250	01->20	P
WR F 400	01->02	P
YZ-F 426	01->02	P
WR F 450	03->19	P
YZ-F 450	03->19	P

**DF5052** | **A**  
 ØE:220 ØC:116,2 ØI:100,2 ØF:6,6 N°:6 SP:4

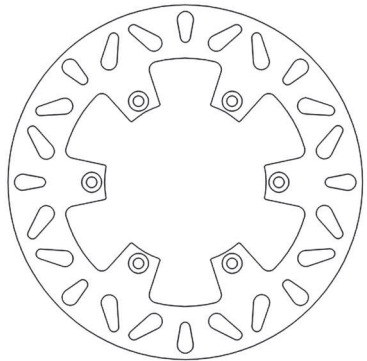

**KAWASAKI**

	Year	A/P
KX 125	89->99	P

**...DF5052**

... segue <b>KAWASAKI</b>	Year	A/P
KX 250	89->99	P
KLX 300	97->06	P
KX 500	89->99	P
KLX 650 R	93->97	P

**DF5053** | **A**  
 ØE:240 ØC:125 ØI:105,2 ØF:6,3 N°:4 SP:4

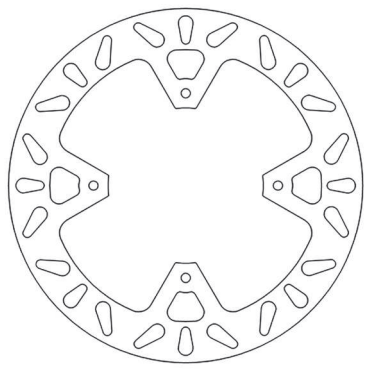

**HONDA**

	Year	A/P
XR 650 R	00->07	P

**DF5054** | **A** | **AP** | **OE**  
 ØE:240 ØC:140 ØI:121,1 ØF:6,5 N°:4 SP:4

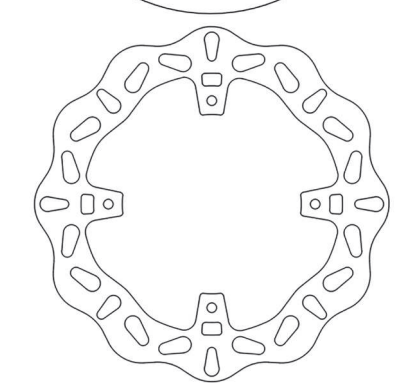
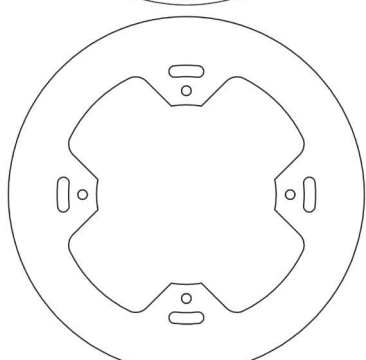
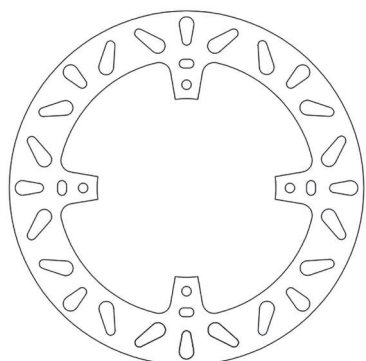

**HONDA**

	Year	A/P
CR 125 R	02->07	P



...DF5054		
... segue HONDA	Year	A/P
CRE 125	02->07	P
CR 250 R	02->10	P
CRE 250	02->07	P
CRE 250 IE	07->08	P
CRF 250 R - E	04->20	P
CRF 250 X	04->17	P
CRE 290 IE	07->08	P
CRF 300 X	08->12	P
CRF 450 R - E	02->20	P
CRF 450 RX	17->19	P
CRF 450 X	05->20	P
CRM 450 X SUPERMOTARD	07->	P
CR 500 R	02->	P
CRM 500 X SUPERMOTARD	07->	P

DF5057	A
ØE:220 ØC:116,2 ØI:100,2 ØF:6,6 N°:6 SP:4	

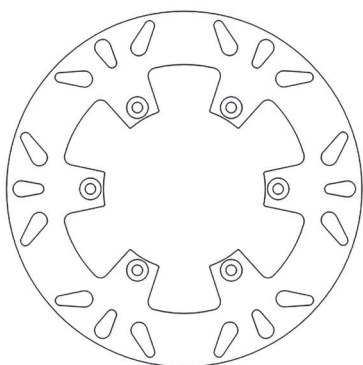

KAWASAKI	Year	A/P
KX 125	00->02	P
KX 250	00->02	P
KX 500	00->04	P

DF5062	A
ØE:276 ØC:198 ØI:175,6 ØF:10,5 N°:5 SP:5	

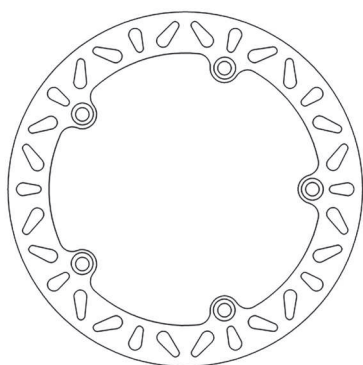

BMW	Year	A/P
R 850 C	97->01	P
R 850 GS	98->07	P
R 850 R (21_0097 - 259R)	94->01	P
R 850 R (21_0145 - R28)	99->07	P
R 850 R ROADSTER	95->00	P
R 850 RT (21_0097 - 259T)	96->01	P
R 850 RT (21_0145 - R22)	00->06	P
R 850 RT INTEGRAL ABS	01->04	P
R 100 R 1000	91->95	P
R 1100 GS	93->01	P
R 1100 R	93->01	P
R 1100 RT	94->01	P
R 1100 S	96->05	P
R 1100 S ABS	00->06	P
R 1100 S BOXER CUP REPLICA	03->06	P
R 1150 GS	00->03	P

...DF5062		
... segue BMW	Year	A/P
R 1150 GS ADV	01->05	P
R 1150 R	01->06	P
R 1150 R ROCKSTER	02->06	P
R 1150 RS	00->05	P
R 1150 RT	00->06	P

DF5063	A
ØE:270 ØC:180 ØI:160 ØF:10,5 N°:6 SP:5	

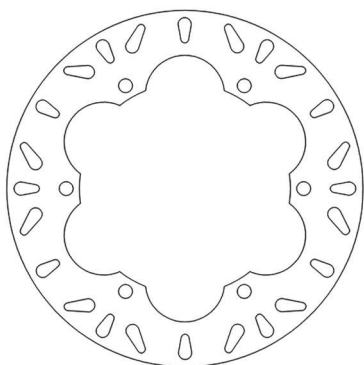

KAWASAKI	Year	A/P
GPX 750	87->89	A

DF5064	A
ØE:280 ØC:111,7 ØI:93 ØF:8,5 N°:5 SP:5	

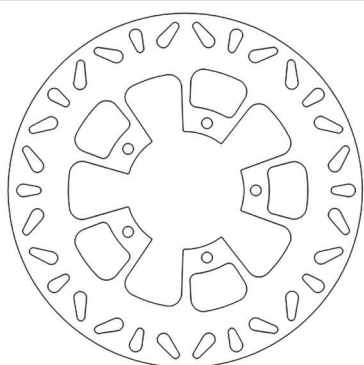

MOTO GUZZI	Year	A/P
QUOTA 1000	92->97	A

DF5065	A
ØE:230 ØC:104 ØI:82,1 ØF:10,5 N°:5 SP:5	

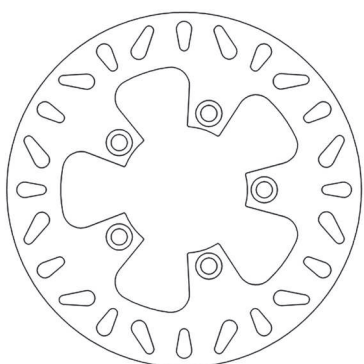

KAWASAKI	Year	A/P
ZX-7R 750 NINJA	89->03	P
ZX-7RR 750 NINJA	96->02	P
ZXR 750	89->90	P
ZXR 750 L	93->95	P
ZXR 750 R	91->95	P

...DF5065		
... segue KAWASAKI	Year	A/P
ZX-9 900 R NINJA	94->97	P
GTR 1000	86->93	P
ZR 1100 ZEPHYR (ZR 1100 A)	96->98	P

DF5066	A
ØE:240 ØC:110,2 ØI:89,1 ØF:10,5 N°:5 SP:5	

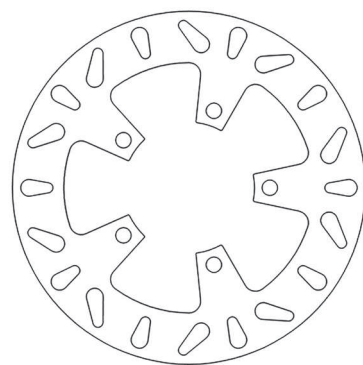

SUZUKI	Year	A/P
GSF 600 BANDIT	95->04	P
GSX 600 F	98->06	P
RF 600 RR	93->96	P
SV 650	99->02	P
SV 650 S	99->02	P
GSX 750 F	98->06	P
GSX-R 750	88->92	P
GSX-R 750 SP	93->95	P
RF 900 RR	94->95	P
RF 900 RT - RV	96->99	P
GSX-R 1100	89->96	P
GSF 1200 BANDIT	96->05	P
GSF 1200 S BANDIT	97->05	P
GSX 1200 X	99->01	P
GV 1200 GL MADURA	85->86	P
GSF 1250 S BANDIT	07->12	P
GSX-R 1300 HAYABUSA	99->07	P

DF5067	A
ØE:220 ØC:120 ØI:100,1 ØF:10,5 N°:4 SP:5	

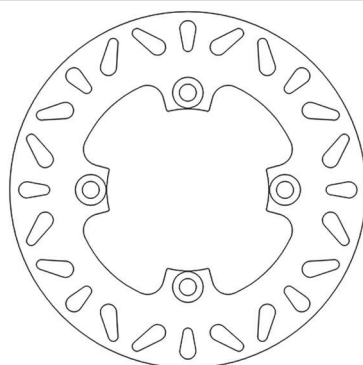

KAWASAKI	Year	A/P
ZX-6 RR 600 NINJA	03->06	P
ZX-6R 600 NINJA	98->12	P
ZX-6R 636 NINJA	02->06	P
ER - 6F 650 ABS	06->12	P
ER - 6N 650 ABS	06->12	P
KLE 650 VERSYS	07->17	P
KLE 650 VERSYS ABS	07->14	P
Z 750 J (ZR)	04->06	P
Z 750 S (ZR)	05->07	P
ZX-9 900 R NINJA	98->04	P
Z 1000	03->06	P
ZX-10R 1000 NINJA	04->10	P

**DF5068**

**A**

ØE:250 ØC:138 ØI:124,1 ØF:6,5 N°:6 SP:4

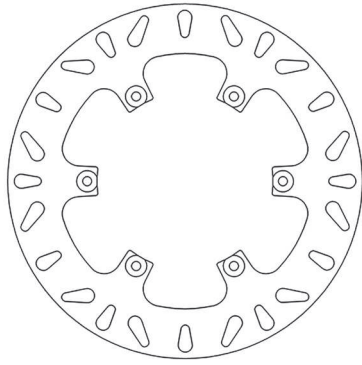

GILERA	Year	A/P
RC 125 TOP RALLY	89->	A

**DF5071**

**A**

ØE:220 ØC:120 ØI:102 ØF:8,5 N°:5 SP:5

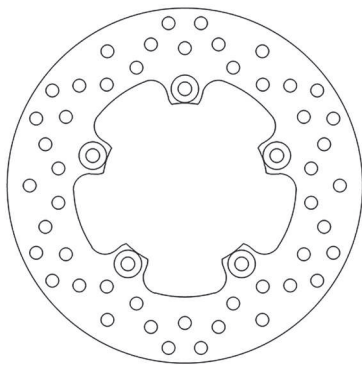

APRILIA	Year	A/P
RS 250	95->03	P
RST 1000 FUTURA	01->03	P
RSV 1000 MILLE	97->03	P
RSV 1000 MILLE NERA	04	P
RSV 1000 MILLE R	00->07	P
RSV 1000 MILLE R FACTORY	04->05	P
RSV 1000 SP	99->00	P
RSV 1000 TUONO	02->05	P
RSV 1000 TUONO FIGHTER	03->05	P
RSV 1000 TUONO R	03->12	P
RSV4 1000 FACTORY	09->10	P
RSV4 1000 FACTORY ABS	13	P
RSV4 1000 FACTORY APRC	11->12	P
RSV4 1000 FACTORY APRC R - ABS	11->13	P
RSV4 1000 FACTORY APRC STD-SE	11->12	P
RSV4 1000 SBK RACING	09->10	P
RSV4-R 1000	10	P
RSV4-R 1000 APRC - ABS	11->14	P
SL 1000 FALCO	00->04	P
TUONO 1000 V4R APRC	14	P
TUONO 1000 V4R STD APRC	11->13	P
CAPO NORD 1200	13->19	P
CAPO NORD 1200 RALLY	15->19	P
CAPO NORD 1200 TRAVEL PACK	16->19	P

BENELLI	Year	A/P
TORNADO TRE 900	03->06	P
TORNADO TRE 900 RS	04->06	P

LAVERDA	Year	A/P
SFC 1000	03->	P

MONDIAL	Year	A/P
PIEGA 999 (1000cc)	03->	P
PIEGA EVO 999 (1000cc)	03->	P
PIEGA NUDA 999 (1000cc)	04->	P
RZ NUDA 999 (1000cc)	02->	P
RZ STARFIGHTER 999 (1000cc)	02->	P

**DF5072**

**A**

ØE:240 ØC:125 ØI:105 ØF:10,5 N°:4 SP:6

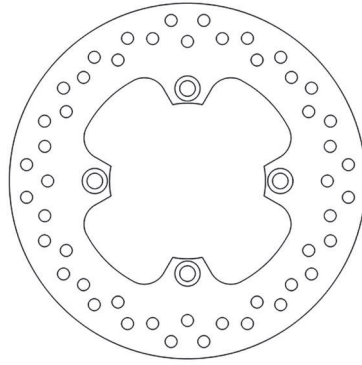

HONDA	Year	A/P
FORZA 300 NSS	12->	P
SILVER WING 400 EJS	06->08	P
SW-T 400	09->	P
SW-T 400 ABS	09->	P
SILVER WING 600 FSC	01->07	P
SILVER WING 600 FSC ABS	03->08	P
SW-T 600	11->18	P

**DF5073**

**A**

ØE:256 ØC:166 ØI:144,4 ØF:10,5 N°:4 SP:4

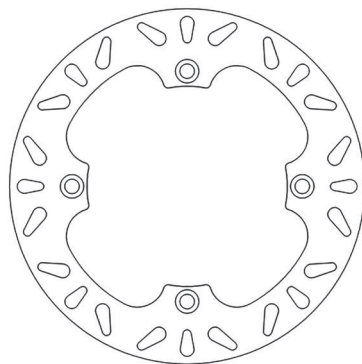

HONDA	Year	A/P
CB 350 SG	86->88	A
CB S 450	85->89	A
XL 600 V TRANSALP	97->99	A
NX 650 DOMINATOR	88->04	A
XL 650 V TRANSALP	00->07	A
XR 650 L	93->12	A
XL 700 V TRANSALP	08->11	A
XL 700 V TRANSALP ABS	08->11	A

**DF5074**

**A**

ØE:220 ØC:133 ØI:115,1 ØF:8,6 N°:6 SP:5

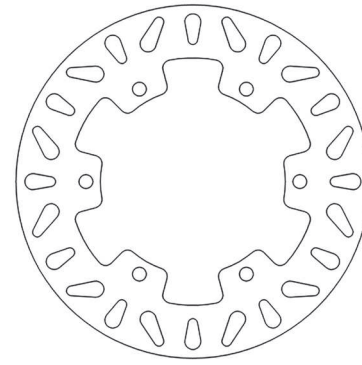

YAMAHA	Year	A/P
YZ-F 600 R6	99->02	P
YZ-F 1000 R1	02->03	P

**DF5075**

**A**

**AP**

ØE:220 ØC:130 ØI:125 ØF:19,7 N°:4 SP:4

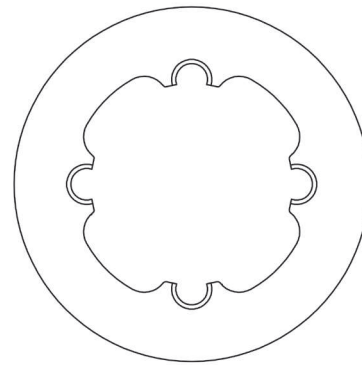
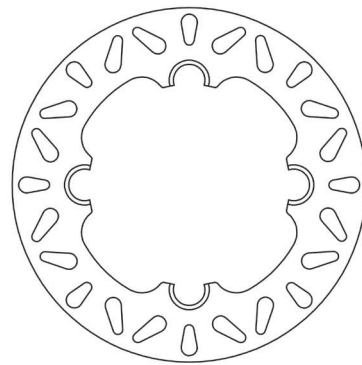

HUSQVARNA	Year	A/P
WR 250	04->06	P
WR 360	02->13	P
TC 400	02->	P
TE 410	02->13	P
TC 450	02->03	P
TC 510	02->03	P
TC 570	01	P
TE 570	01	P
TE 610 E	04->13	P

FIGURATO DISCHI FRENO CON APPLICAZIONI | BRAKE DISCS DRAWINGS AND APPLICATIONS | DESSINS DISQUES DE FREIN AVEC APPLICATIONS |  
DISEÑOS DISCOS DE FRENO CON RELACION | ZEICHNUNGEN VON BREMSSCHEIBEN MIT VERWENDUNGSLISTE



**DF5076**
**A | AF**

ØE:240 ØC:134 ØI:118,1 ØF:6,5 N°:4 SP:3

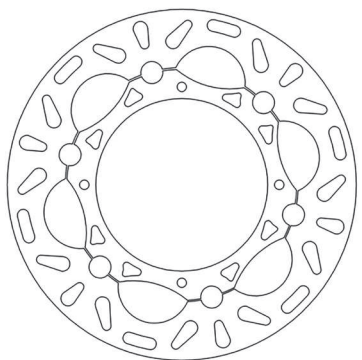
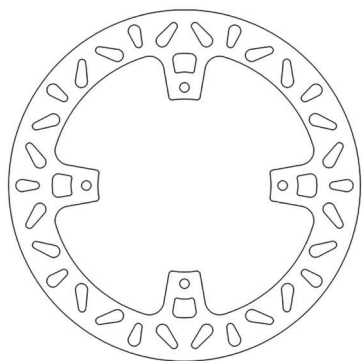

HONDA	Year	A/P
SL 230	97->01	A
XLR 250 R BAJA	88->91	A
XR 250	00->03	A
XR 250 BAJA	00->03	A
XR 250 R	86->04	A
XR 400 R	96->05	A
XR 440 R (DALLARA)	99->	A
XL 600 L	85->87	A
XL 600 R	83->87	A
XR 600 L - R	93->00	A
XR 600 R	85->92	A
XR 650 R	00->07	A

**DF5078**
**A | AF**

ØE:282 ØC:150 ØI:132,1 ØF:8,6 N°:6 SP:5

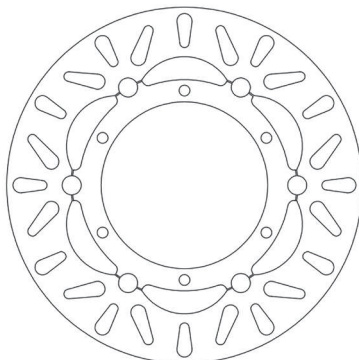
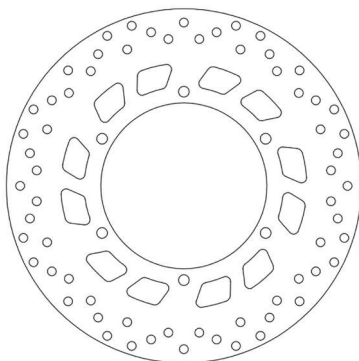

YAMAHA	Year	A/P
XV 125 VIRAGO	97->01	A
XVS 125 DRAGSTAR	00->04	A
XVS 125 VIRAGO	97->00	A
XVS 250 DRAGSTAR	01->04	A
XVS 250 VIRAGO	95->00	A
T MAX 500 XP	01->03	A
XT E 600	95->02	A
XT K 600	91->93	A
XT Z 660 TENERE	91->96	A
XV 750 VIRAGO	94->97	A
GTS 1000	93->99	P
EJ 1100 J	84->85	A / P
XV 1100 VIRAGO	94->98	A
XV 1100 VIRAGO	99->00	P
XVS 1100 A DRAG STAR CLASSIC	00->06	P
XVS 1100 DRAG STAR	99->04	P
EJ 1200	86->87	A
EJ 1200	86->91	P
EJ 1200 ABS	91->95	P
V-MAX 1200 (YMX 12N)	91->92	A
V-MAX 1200 (YMX 12N)	91->03	P
XT 1200 Z SUPER TENERE	10->20	P
XT 1200 ZE SUPER TENERE	14->19	P
EJR 1300 A	13->20	P
EJR 1300 ABS	03->05	P
XV 1700 WARRIOR	03->04	P

**DF5079**
**A**

ØE:267 ØC:150 ØI:132,1 ØF:8,6 N°:6 SP:5

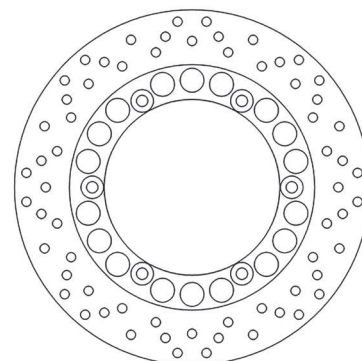

YAMAHA	Year	A/P
SR 125	97->02	A
RD 350 LC N-F all models	85->92	A / P
FZR 400 GENESIS	86	A
FZR 400 RSP	87	A
RD 500 LC	84->86	A
RD 500 YPVS LC	87->	A
T MAX 500 XP	01->03	P
T MAX 500 XP	04->11	P
T MAX 500 XP ABS	05->11	P
T MAX SV 500 XP	11	P
T MAX SV 500 XP ABS	10->11	P
XT 500	86->89	A
SRX 600	85->87	A
XJ 600	83->91	A / P
XT 600 4 VALVES	84->90	A
XT E 600	90->94	A
XT Z 600 TENERE	83->90	A
FZ 750 GENESIS	87->88	A
FZ 750 GENESIS	87->92	P
FZR 750 GENESIS	87->	P
XV 750 VIRAGO	92->93	A
XJ 900 F	85->90	A
XJ S 900 DIVERSION	95->03	P
FZR 1000 EX-UP	91->93	P
FZR 1000 GENESIS	86->89	P
FZR 1000 R	94->95	P
FZR 1000 R - EX-UP	89->90	P
FZS 1000 FAZER	01->05	P
XV 1000 SE VIRAGO	88	A
BT 1100 BULLDOG	02->06	P
XV 1100 VIRAGO	86->93	A
XJR 1200	95->98	P
XJR 1300	99->11	P
XJR 1300 SP	01	P
MT-01 1670	05->16	P

**DF5080**

A | AP | OE

ØE:240 ØC:133 ØI:115,1 ØF:10,5 N°:4 SP:4

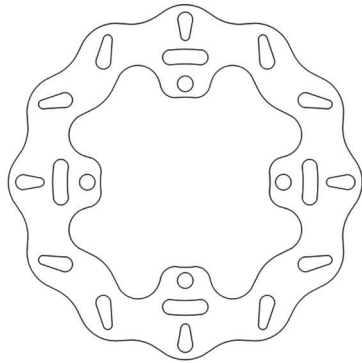
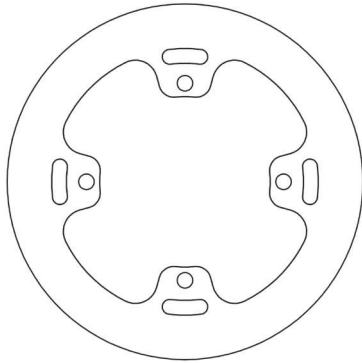
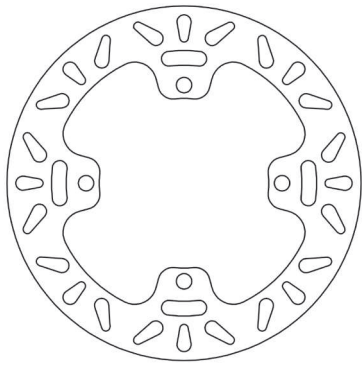

KAWASAKI	Year	A/P
KX 125	03->08	P
KX 250	03->08	P
KX F 250	04->19	P
KLX 450 R	08->20	P
KX F 450	06->18	P

SUZUKI	Year	A/P
RMZ 250	04->06	P

**DF5081**

A | AF

ØE:260 ØC:135 ØI:120,2 ØF:6,5 N°:4 SP:3

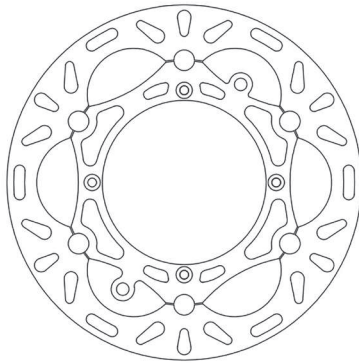
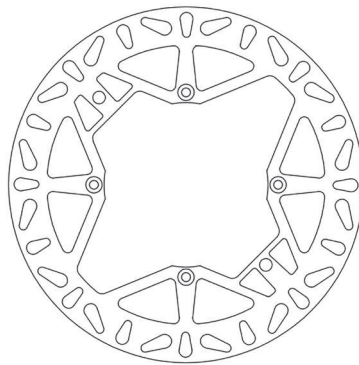

HUSQVARNA	Year	A/P
CR 125	96->13	A
WR 125	98->13	A
WRE 125	95->13	A
WRE 125 DUAL	95->03	A
CR 250	96->13	A
TC 250	02->13	A
TE 250	02->13	A
TXC 250	10->13	A
WR 250	98->13	A
WR 360	00->13	A
TC 400	02->	A
TE 410	00->13	A
TC 449	11->13	A
TE 449	11->13	A
TC 450	02->10	A
TE 450	02->10	A
TC 510	02->10	A
TE 510	02->10	A
TE 511	11->13	A
TC 570	01->13	A
TE 570	01->13	A
TE 610 E	00->13	A

**DF5090**

A

ØE:282 ØC:149,5 ØI:132,2 ØF:8,6 N°:6 SP:4

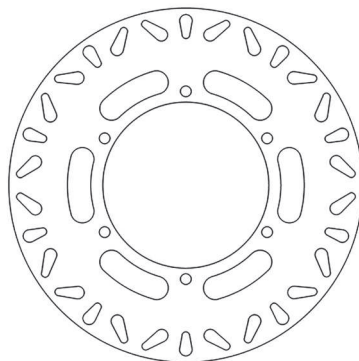

YAMAHA	Year	A/P
TZR 50	96->02	A

**...DF5090**

... segue YAMAHA	Year	A/P
TZR 80	96->98	A
TZR 125	87->95	A
TZR 125 R	91->95	A
TZR 125 RED ROCKET	93->95	A

**DF5091**

A

ØE:245 ØC:102 ØI:86,1 ØF:7 N°:6 SP:3

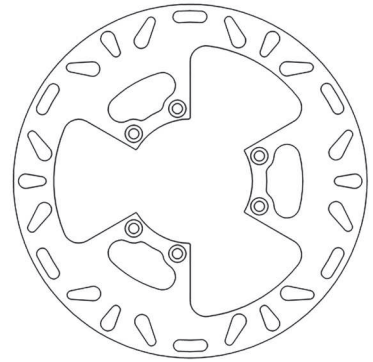

YAMAHA	Year	A/P
WR 125	91->97	A
YZ 125	90->97	A
WR 250 Z	91->98	A
YZ 250	90->97	A
XT 350	85->90	A
YZ 360	89->	A
YZ 360 RALLY	90->93	A

**DF5094**

A

ØE:270 ØC:190 ØI:170,1 ØF:9,6 N°:6 SP:3,2

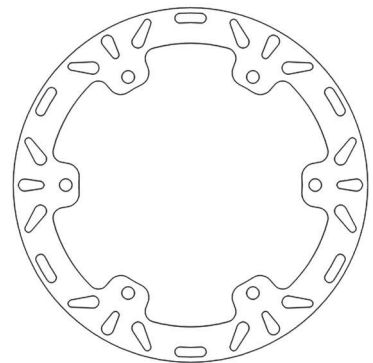

TM	Year	A/P
all models 125	90->93	A
EN 125	94->03	A
MX 125	94->03	A
EN 250	95->03	A
EN 250 F	95->03	A
all models 300	98->04	A
400 F	00	A
all models 400 4T	01->	A
SMX 450 F	04->	A
EN 530 F	03->04	A
MX 530 F 4T	03->04	A

FIGURATO DISCHI FRENO CON APPLICAZIONI | BRAKE DISCS DRAWINGS AND APPLICATIONS | DESSINS DISQUES DE FREIN AVEC APPLICATIONS |  
DISEÑOS DISCOS DE FRENO CON RELACION | ZEICHNUNGEN VON BREMSSCHEIBEN MIT VERWENDUNGSLISTE



## DF5095

A

ØE:240 ØC:128 ØI:115 ØF:6,5 N°:6 SP:4

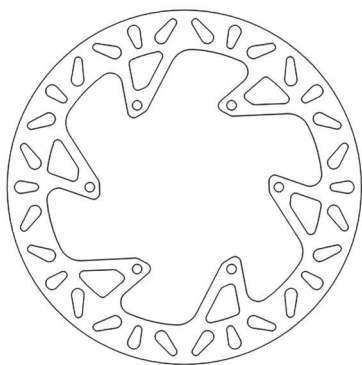

TM	Year	A/P
all models 80 (solo fascia frenante)	94->03	P
all models 85 (solo fascia frenante)	98->03	P
all models 125	90->93	P
EN 125	94->00	P
MC 125	86->89	P
MX 125	94->00	P
SMR 125	05->	P
EN 250	95->00	P
EN 250 F	95->00	P
SMR 250 2T	02->	P
SMR 250 F ES	03->	P
all models 300	98->00	P
400 F	00	P
all models 400 4T	01->	P
CROSS 400	-> 0	P
SMF 400 F	02	P
SMR 450 F ES	02->04	P
SMX 450 F	04->	P
EN 530 F	03->04	P
MX 530 F 4T	03->04	P
SMR 530 F ES	03->	P

## DF5097

AF

ØE:270 ØC:124 ØI:110 ØF:6,5 N°:6 SP:3

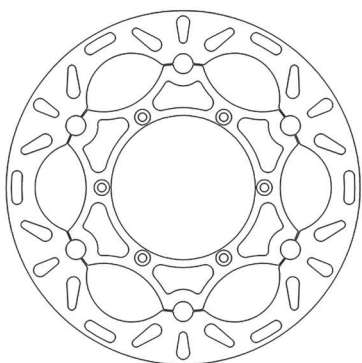

VOR	Year	A/P
all models 400	00->	A
all models 450	00->	A
all models 492	99->	A
all models 495	99->	A
all models 503	00->	A
all models 530	02->	A
EN 530	02->	A
MX 530	02->	A

## DF5098

A

ØE:220 ØC:124 ØI:110,1 ØF:6,5 N°:6 SP:5

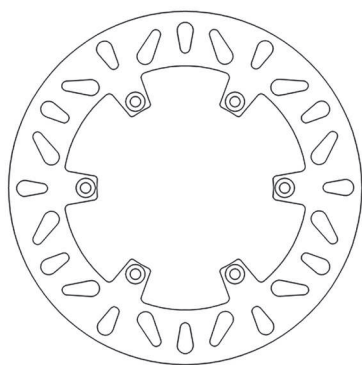

VOR	Year	A/P
all models 400	00->	P
EN 400	02->	P
all models 450	00->	P
SM 450	02->	P
all models 492	99->	P
SUPERMOTARD 492	00->	P
all models 495	99->	P
SUPERMOTARD 500	00->01	P
all models 503	00->	P
all models 530	02->	P
EN 530	02->	P
MX 530	02->	P
SM 530	02->	P

## DF5101

AF

ØE:270 ØC:134 ØI:118,2 ØF:6,5 N°:4 SP:3

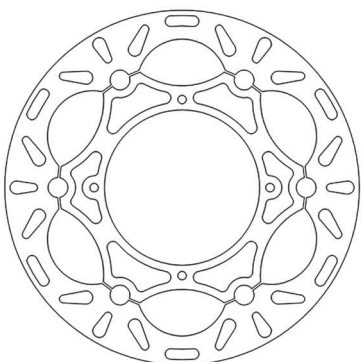

HONDA	Year	A/P
XR 400 R	96->05	A
XR 440 R (DALLARA)	99->	A
XR 600 L - R	93->00	A
XR 600 R	91->92	A
XR 650 R	00->07	A

## DF5102

A

ØE:240 ØC:130 ØI:126 ØF:19 N°:4 SP:3,5

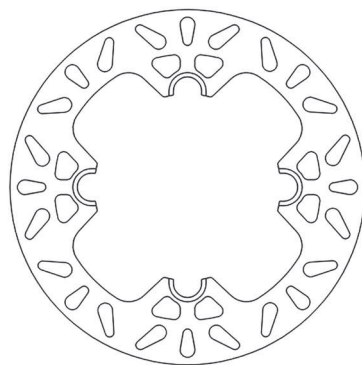

HUSQVARNA	Year	A/P
CR 125	04	P
WR 125	04->05	P
WRE 125	05->13	P
CR 250	04	P
TE 250	04->13	P
TE 510	02->04	P
TC 570	02->13	P
TE 570	02->13	P

## DF5103

A

AP

OE

ØE:240 ØC:125 ØI:110 ØF:6,5 N°:6 SP:4

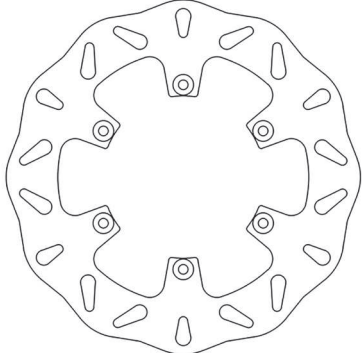
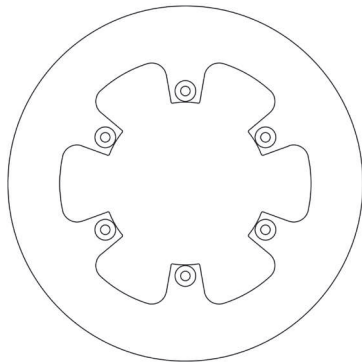
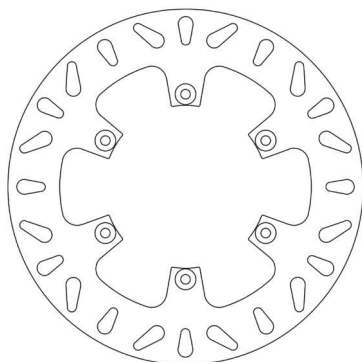

BETA	Year	A/P
RR 250	13	P

...DF5103		
... segue BETA	Year	A/P
RR 250 2T ENDURO	14->17	P
RR 300 2T ENDURO	13->17	P
RR 350 4T ENDURO	13->17	P
RR 390 4T ENDURO	15->17	P
RR 400 4T ENDURO	13->14	P
RR 430 4T ENDURO	15->17	P
RR 450 4T ENDURO	13->15	P
RR 450 CROSS	13->14	P
RR 480 4T ENDURO	15->17	P
RR 498 4T ENDURO	12->14	P
RR 498 4T FACTORY	12	P
KTM	Year	A/P
LC4 690 ENDURO	08->14	P
LC4 690 ENDURO R	09->20	P
LC4 690 RALLY REPLICA	07->10	P
LC8 950 ADVENTURE	03->05	P
LC8 950 ADVENTURE S	03->05	P
LC8 950 SUPER ENDURO	06->08	P
LC8 950 SUPER ENDURO R	06->08	P
LC8 990 ADVENTURE	06->12	P
LC8 990 ADVENTURE DAKAR	09->12	P
LC8 990 ADVENTURE R	09->12	P
LC8 990 ADVENTURE S	06->08	P

**DF5104** **AF**

ØE:250 ØC:116 ØI:100,5 ØF:9,3 N°:4 SP:3

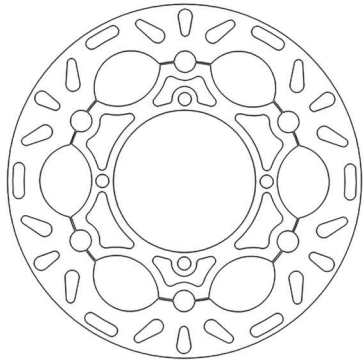

KAWASAKI	Year	A/P
KX 125	03->05	A
KX 250	03->05	A
KX F 250	04->05	A
SUZUKI	Year	A/P
RMZ 250	04->06	A

**DF5105** **AF**

ØE:270 ØC:116 ØI:100,4 ØF:9,3 N°:4 SP:3

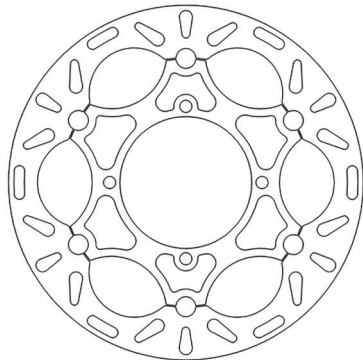

KAWASAKI	Year	A/P
KX 125	03->05	A
KX 250	03->05	A
KX F 250	04->05	A
SUZUKI	Year	A/P
RMZ 250	04->06	A

**DF5106** **A**

ØE:280 ØC:146,3 ØI:130,1 ØF:10,6 N°:9 SP:5

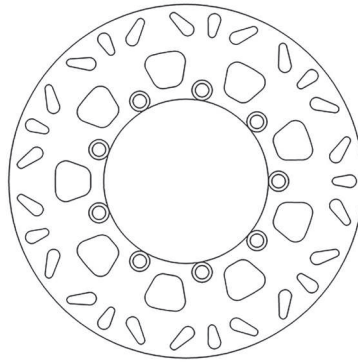

KAWASAKI	Year	A/P
KL 650 TENGAI	89->92	A
KLR 650	95->04	A

**DF5107** **A** **AF**

ØE:300 ØC:143 ØI:127,1 ØF:6,5 N°:6 SP:5

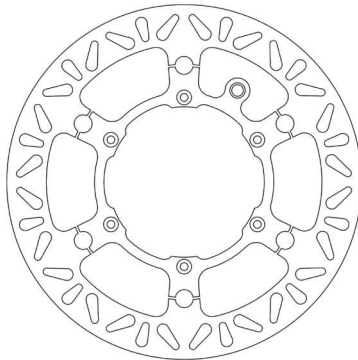
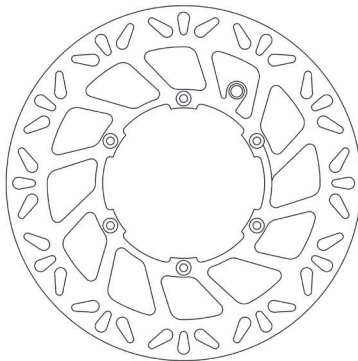

KTM	Year	A/P
LC8 950 SUPER ENDURO	06->08	A
LC8 950 SUPER ENDURO R	06->08	A

**DF5108** **A**

ØE:320 ØC:203,7 ØI:180 ØF:8,5 N°:5 SP:5

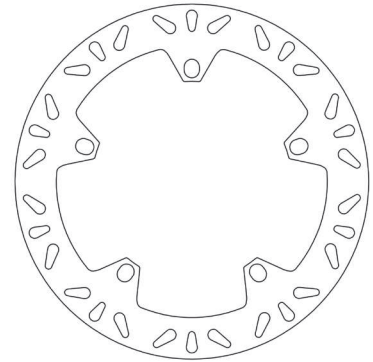

BMW	Year	A/P
F 800 GT	13->20	A
F 800 S	06->10	A
F 800 ST	06->12	A
R 850 RT INTEGRAL ABS	01->04	A
R 1100 S	01->05	A
R 1100 S BOXER CUP REPLICA	03->06	A
R 1150 R	01->06	A
R 1150 R ROCKSTER	02->06	A
R 1150 RS	00->05	A
R 1150 RT	00->06	A
HP2 1200 MEGAMOTO	07->10	A
HP2 1200 SPORT	08->11	A
K 1200 GT	02->07	A
K 1200 LT	02->08	A
K 1200 R	05->11	A
K 1200 RS	01->05	A
K 1200 S	05->08	A
R 1200 R	06->14	A
R 1200 RT	03->07	A
R 1200 S	04->07	A
R 1200 ST	05->07	A

**DF5109** **A**

ØE:220,6 ØC:112 ØI:96,2 ØF:9,3 N°:6 SP:3

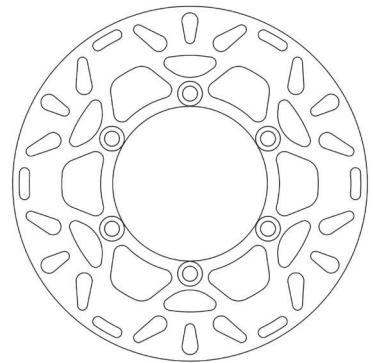

KAWASAKI	Year	A/P
KX 80	93->00	A
KX 85	01->13	A
KX 100	01->20	A



## DF5112 A

ØE:185 ØC:92,2 ØI:69,4 ØF:15,6 N°:4 SP:3

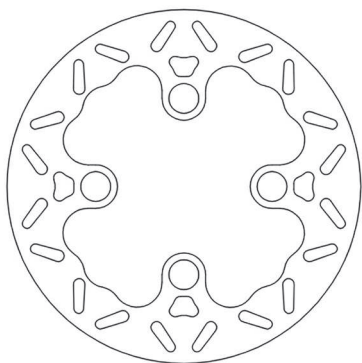

GAS GAS	Year	A/P
TXT 125 PRO RACING	14	A
TXT 125 PRO REPLICA	13	A
TXT 250 PRO RACING	14->19	A
TXT 250 PRO REPLICA	13->14	A
TXT 280 PRO RACING	14->19	A
TXT 280 PRO REPLICA	13	A
TXT 300 PRO RACING	14->19	A
TXT 300 PRO REPLICA	13	A

HONDA	Year	A/P
COTA 250 4RT	05->16	A
COTA 260 4RIDE	16->19	A
COTA 260 4RT	14->16	A
COTA 260 4RT RACE REPLICA	15->19	A

MONTESA	Year	A/P
COTA 250 4RT	05->16	A
COTA 260 4RIDE	16->19	A
COTA 260 4RT	14->16	A
COTA 260 4RT RACE REPLICA	15->19	A
COTA 300 RR	16->19	A

SHERCO	Year	A/P
CITY CORP 125 4T ENDURO	03->07	A
CITY CORP 125 4T SM	03->07	A
ST 125	99	A
ST 125 1.25	06->11	A
ST 250 2.5	01	A
ST 290 2.9	01	A
ST 320 3.2 4T	05	A

VERTIGO	Year	A/P
COMBAT 300 CAMO	15->	A
COMBAT 300 ICE HELL	15->	A

## DF5113 A

ØE:150 ØC:60 ØI:46,9 ØF:6,5 N°:4 SP:2,8

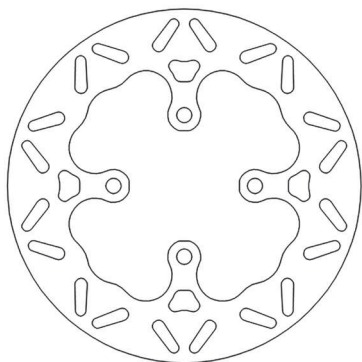

SHERCO	Year	A/P
CITY CORP 125 4T ENDURO	03->07	P
CITY CORP 125 4T SM	03->07	P
ST 125	99	P
ST 125 1.25	06->11	P
ST 250 2.5	01	P
ST 290 2.9	01	P
ST 320 3.2 4T	05	P

## DF5114 AF

ØE:270 ØC:143 ØI:127,1 ØF:6,6 N°:6 SP:3

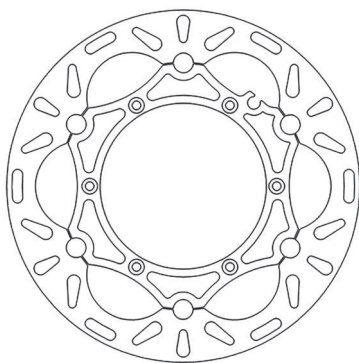

HUSQVARNA	Year	A/P
TC 125	14->20	A
TE 125	14->16	A
TE 125 4T	11->13	A
TX 125	17->20	A
FC 250	14->20	A
FE 250	13->20	A
TC 250	14->20	A
TE 250	14->17	A
TE 250 i	18->20	A
TC 300	14->17	A
TE 300	14->17	A
TE 300 i	18->20	A
TX 300	19	A
TX 300 i	20	A
FC 350	14->20	A
FE 350	14->20	A
FX 350	17->20	A
FC 450	14->20	A
FE 450	14->20	A
FX 450	19->20	A
TE 450	14	A
FE 501	14->20	A

KTM	Year	A/P
EXC 125	98->15	A
EXC 125 SIX DAYS	01->16	A
EXE 125	00->11	A
SX 125	96->20	A
SXS 125	01->10	A
SX 144	07->10	A
SX 150	08->20	A
XC 150	11->18	A
EXC 200	04->16	A
SX 200	03->07	A
XC-W 200	11->16	A
EXC 250	94->17	A
EXC 250 SIX DAYS (2T)	05->17	A
EXC 250 SIX DAYS TPI (2T)	18->20	A
EXC 250 TPI (2T)	18->20	A
EXC RACING 250 (4T)	00->06	A
EXC-F 250	06->20	A
EXC-F 250 SIX DAYS	07->20	A
MX 250	00->13	A
SX 250	94->20	A
SX-F 250	05->20	A
SXS 250	01->03	A
SXS-F 250	06->08	A
XC 250 (2T)	94->17	A
XC 250 TPI (2T)	18->19	A
XC-F 250	11->20	A
XC-W 250 (2T)	11->17	A
XC-W 250 TPI (2T)	18->19	A
XCF-W 250	12->17	A
EXC 300	94->16	A
EXC 300 EGS	93->99	A
EXC 300 SIX DAYS (2T)	05->17	A
EXC 300 SIX DAYS TPI (2T)	18->20	A
EXC 300 TPI (2T)	18->20	A
XC 300 (2T)	11->19	A

## ...DF5114

... segue KTM	Year	A/P
XC 300 TPI (2T)	20	A
XC-W 300 (2T)	14->18	A
XC-W 300 SIX DAYS (2T)	18	A
XC-W 300 TPI (2T)	19->20	A
XC-W 300 TPI SIX DAYS (2T)	19->20	A
EXC-F 350	12->20	A
EXC-F 350 SIX DAYS	12->20	A
SX-F 350	11->20	A
XC-F 350	11->20	A
XCF-W 350	11->20	A
EXC 360	96->97	A
SX 360	96->97	A
EXC 380	98->02	A
MXC 380	98->02	A
SX 380	98->02	A
EXC 400	00->04	A
EXC RACING 400	00->07	A
EXC-G RACING 400	04->08	A
MXC 400	00->02	A
SX 400	00->02	A
SX RACING 400	02	A
SXC 400	99->00	A
EXC RACING 450	03->07	A
EXC-F 450	17->20	A
EXC-F 450 SIX DAYS	17->20	A
EXC-R 450	08->16	A
EXC-R RACING 450 (USA)	11	A
MXC 450	04->06	A
SX 450	03->06	A
SX-F 450	07->20	A
XC 450	06->07	A
XC-F 450	14->20	A
XC-W 450	08->16	A
XC-W 450 SIX DAYS (USA)	11	A
EXC 500 4T	12->16	A
EXC-F 500	17->20	A
EXC-F 500 SIX DAYS	17->20	A
XC-W 500	12->16	A
XCF-W 500	20	A
SX-F 505	07->09	A
XC-F 505	07->09	A
EXC RACING 520	00->02	A
MXC 520	00->02	A
SX 520	00->02	A
EXC RACING 525	03->07	A
MXC 525	03->05	A
SX 525	03->07	A
XC 525	06->07	A
EXC-R 530	08->11	A
EXC-R RACING 530 (USA)	11	A
XC-W 530	08->11	A
XC-W 530 SIX DAYS	11	A
XC-W 530 SIX DAYS (USA)	11	A
LC4 540 SXC	98->00	A
SXS 540 RACING	02	A

**DF5115**

**A | AF**

ØE:270 ØC:135 ØI:120,2 ØF:10 N°:4 SP:3

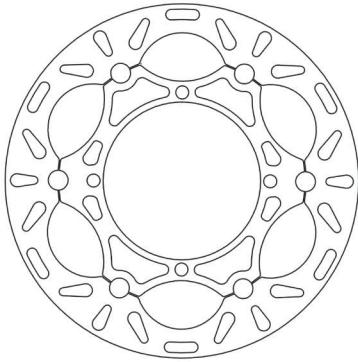
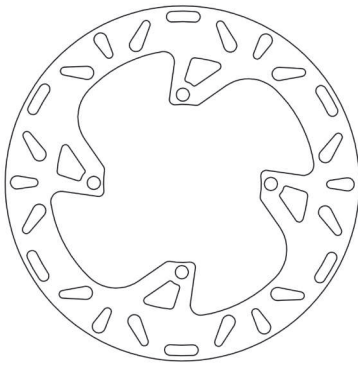

SHERCO	Year	A/P
SE 250 ENDURO 2.5 I	06->11	A
ENDURO 450 4.5 I	04->11	A
SE 510 ENDURO 5.1 I	06->11	A

**DF5116**

**A | AP**

ØE:240 ØC:130 ØI:112,5 ØF:10,4 N°:4 SP:4

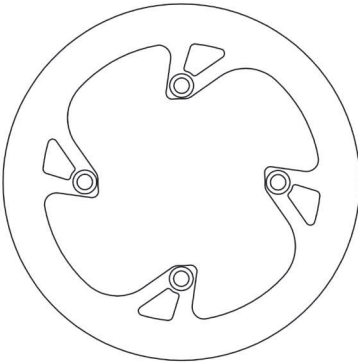
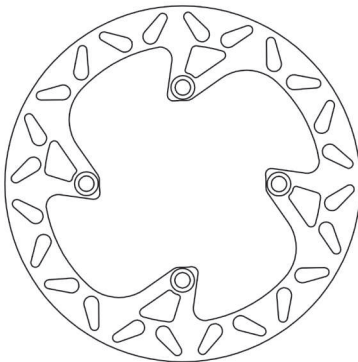

BETA	Year	A/P
RR 250	05->12	P
RR 350 4T ENDURO	11->12	P
RR 350 4T FACTORY	11->12	P
RR 400	05->10	P

**...DF5116**

... segue BETA	Year	A/P
RR 400 4T ENDURO	11->12	P
RR 400 4T FACTORY	10->11	P
RR 450	05->09	P
RR 450 4T ENDURO	11->12	P
RR 450 4T FACTORY	10->12	P
RR 450 CROSS COUNTRY	12	P
RR 520 4T ENDURO	11	P
RR 520 4T FACTORY	10->11	P
RR 525	05->09	P
SHERCO	Year	A/P
SE 250 ENDURO 2.5 I	06->11	P
ENDURO 450 4.5 I	04->11	P
SE 510 ENDURO 5.1 I	06->11	P

**DF5117**

**AF**

ØE:260 ØC:135 ØI:120,2 ØF:8,5 N°:4 SP:3

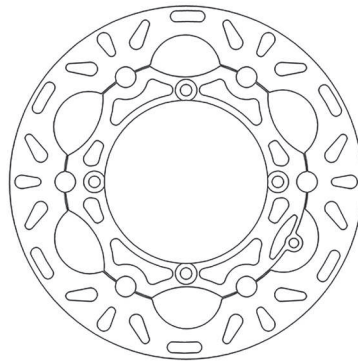

BETA	Year	A/P
RR 250	05->12	A
RR 350 4T ENDURO	11->12	A
RR 350 4T FACTORY	11->12	A
RR 400	05->10	A
RR 400 4T ENDURO	11->12	A
RR 400 4T FACTORY	10->11	A
RR 450	05->09	A
RR 450 4T ENDURO	11->12	A
RR 450 4T FACTORY	10->12	A
RR 450 CROSS COUNTRY	12	A
RR 520 4T ENDURO	11	A
RR 520 4T FACTORY	10->11	A
RR 525	05->09	A

**DF5121**

**A | AP | OE**

ØE:240 ØC:140 ØI:122,2 ØF:10 N°:4 SP:4

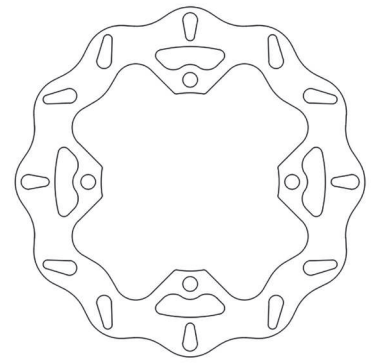
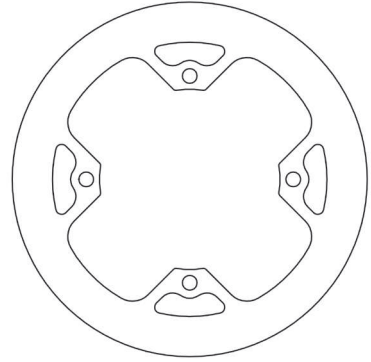
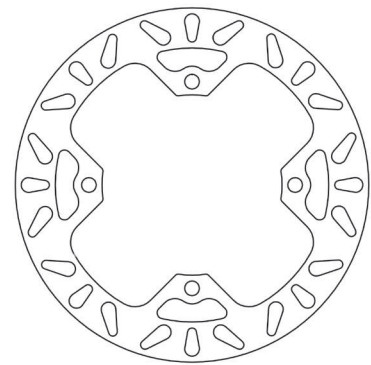

SUZUKI	Year	A/P
RMZ 250	07->18	P
RMX 450	10->17	P
RMZ 450	05->20	P

**DF5122**

**A**

ØE:184 ØC:100 ØI:84,4 ØF:6,5 N°:4 SP:3

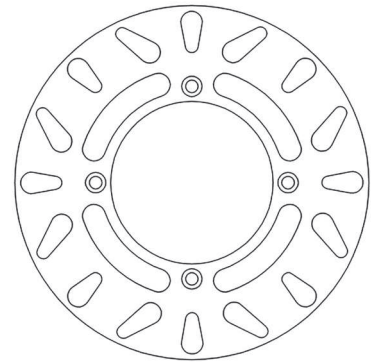

KAWASAKI	Year	A/P
KX 80	93->00	P
KX 85	01->13	P
KX 100	01->20	P
SUZUKI	Year	A/P
RM 80	90->01	P
RM 85	02->04	P

FIGURATO DISCHI FRENO CON APPLICAZIONI | BRAKE DISCS DRAWINGS AND APPLICATIONS | DESSINS DISQUES DE FREIN AVEC APPLICATIONS |  
DISEÑOS DISCOS DE FRENO CON RELACION | ZEICHNUNGEN VON BREMSSCHEIBEN MIT VERWENDUNGSLISTE



**DF5123****A | AF | OE**

ØE:250 ØC:134 ØI:118,2 ØF:9,3 N°:4 SP:3

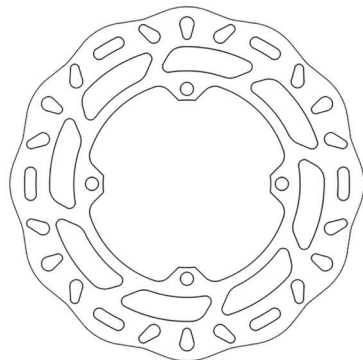
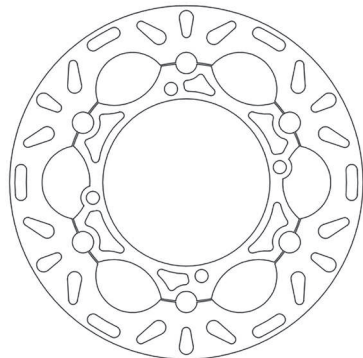
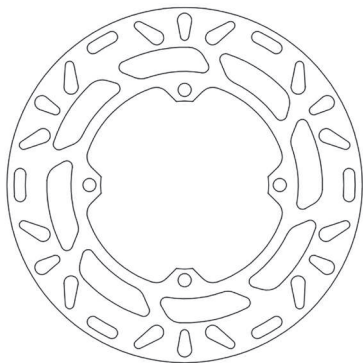

SUZUKI	Year	A/P
RMZ 250	07->18	A
RMX 450	10->17	A
RMZ 450	05->17	A

**DF5124****AF | OE**

ØE:270 ØC:134 ØI:118,2 ØF:9,3 N°:4 SP:3

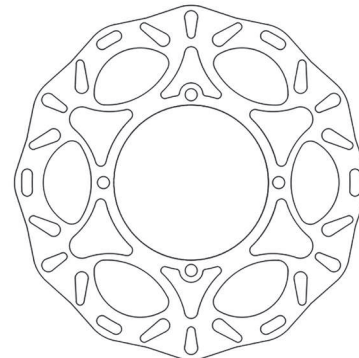
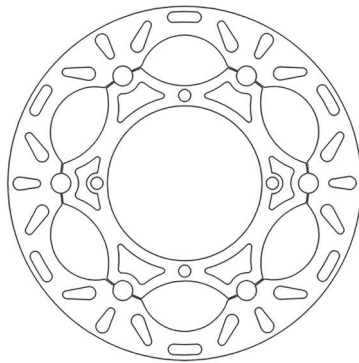

SUZUKI	Year	A/P
RMZ 250	07->18	A
RMZ 250	19	A
RMX 450	10->17	A
RMZ 450	05->17	A
RMZ 450	18->20	A

**DF5125****A | AF**

ØE:300 ØC:101,6 ØI:90,5 ØF:6,5 N°:6 SP:4

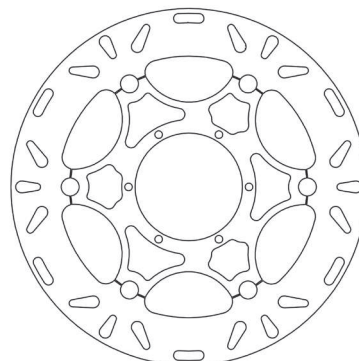
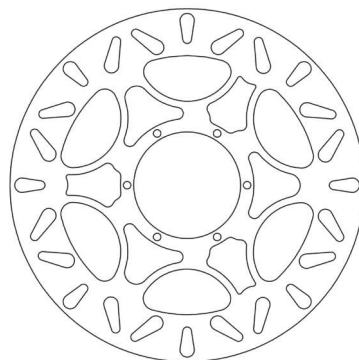

DERBI	Year	A/P
GPR 50 NUDE	06->08	A
GPR 50 NUDE SPORT	08	A

**...DF5125****... segue DERBI**

	Year	A/P
GPR 50 NUDE TUNING	06->08	A
GPR 50 R DRD PRO EU2	05->09	A
GPR 50 R EU2 - REPLICA EU2	08	A
GPR 50 RACING EU2	06	A
GPR 50 REPLICA - R EU2	06	A
GPR 50 REPLICA 2T	07	A
GPR 50 REPLICA PESEK EU2	07	A
GPR 50 SM DRD PRO EU2	05->08	A
GPR 125 NUDE	04->06	A
GPR 125 RACING	04->06	A

**DF5126****A**

ØE:185 ØC:92 ØI:74 ØF:15,5 N°:4 SP:3

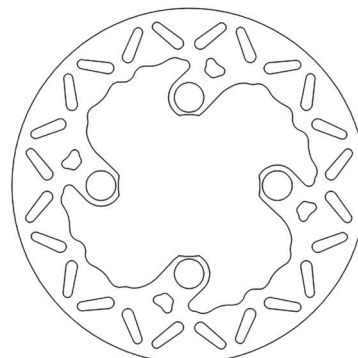

GAS GAS	Year	A/P
TXT 125	01->03	A
TXT 200	00->03	A
TXT 250	00->03	A
TXT 280	00->03	A

**DF5127****A**

ØE:183 ØC:92 ØI:72 ØF:15,5 N°:4 SP:3

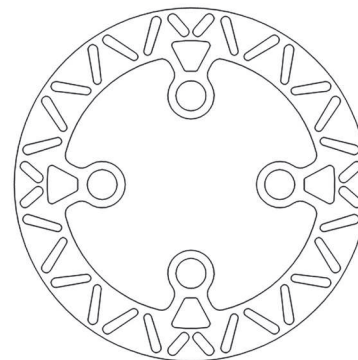

SCORPA	Year	A/P
SY 125 F	03->	A
TY 125 (4T)	05->	A
SY 175 F RACING	05->	A
SY 250	00->	A
SY 250 LONG RIDE	04->	A
SY 250 R	05->	A

**DF5128**

**A**

ØE:150 ØC:60 ØI:45,2 ØF:6 N°:4 SP:3

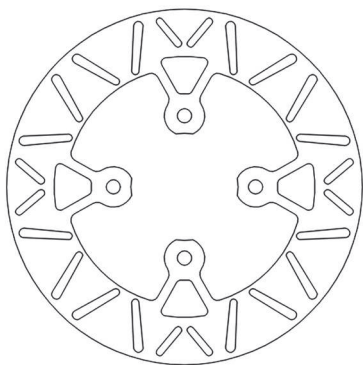

SCORPA	Year	A/P
SY 125 F	03->	P
TY 125 (4T)	05->	P
SY 175 F RACING	05->	P
SY 250	00->	P
SY 250 LONG RIDE	04->	P
SY 250 R	05->	P

**DF5129**

**A**

ØE:296 ØC:166 ØI:144 ØF:10,5 N°:6 SP:5

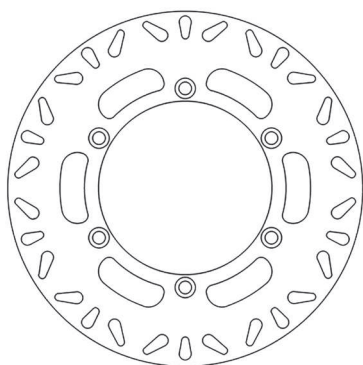

HONDA	Year	A/P
VIZ 250 XELVIS	92->	A
CB 500	94->05	A
CBF 500	04->07	A
CBF 500 ABS	04->07	A
CBF 600	04->07	A
NTV 650 DEAUVILLE	98->05	A
NT 700 V DEAUVILLE	06->12	A
CB 750 F	83->84	A
CB 750 N SEVEN FIFTY	92->02	A
VFR 750 F	90->93	A
VFR 750 F INTERCEPTOR	88->89	A
VT 750 BLACK WINDOW	01->04	A
VT 750 C SHADOW	86->09	A
CBR 1000 F	87->92	A
CBR 1000 F-FP	93->99	A
ST 1100 PAN EUROPEAN	89->02	A
ST 1100 PAN EUROPEAN ABS	92->95	A

**DF5130**

**A**

ØE:185 ØC:92 ØI:74 ØF:6,6 N°:4 SP:3

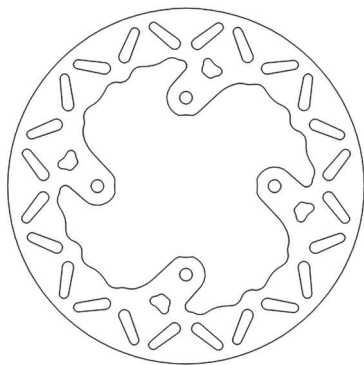

GAS GAS	Year	A/P
TXT 125 PRO	04->13	A
TXT 200 PRO	04->13	A
TXT 250 PRO	07->11	A
TXT 280	04	A
TXT 300	04->06	A

**DF5131**

**A**

ØE:150 ØC:60 ØI:45,2 ØF:6,6 N°:4 SP:3

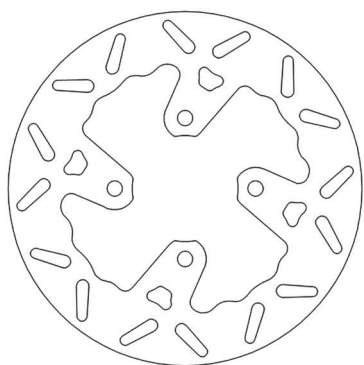

GAS GAS	Year	A/P
TXT 125	01->03	P
TXT 125 PRO	04->13	P
TXT 125 PRO RACING	14	P
TXT 125 PRO REPLICA	13	P
TXT 200	00->03	P
TXT 200 PRO	04->13	P
TXT 250	00->03	P
TXT 250 PRO	07->11	P
TXT 250 PRO RACING	14->19	P
TXT 250 PRO REPLICA	13->14	P
TXT 280	00->03	P
TXT 280 PRO RACING	14->19	P
TXT 280 PRO REPLICA	13	P
TXT 300	04->06	P
TXT 300 PRO RACING	14->19	P
TXT 300 PRO REPLICA	13	P

HONDA	Year	A/P
COTA 250 4RT	05->16	P
COTA 260 4RIDE	16->19	P
COTA 260 4RT	14->16	P
COTA 260 4RT RACE REPLICA	15->19	P

MONTESA	Year	A/P
COTA 250 4RT	05->16	P
COTA 260 4RIDE	16->19	P
COTA 260 4RT	14->16	P
COTA 260 4RT RACE REPLICA	15->19	P
COTA 300 RR	16->19	P

VERTIGO	Year	A/P
COMBAT 300 CAMO	15->	P
COMBAT 300 ICE HELL	15->	P

**DF5136**

**AF**

**OE**

ØE:250 ØC:126 ØI:109,3 ØF:9,3 N°:4 SP:3

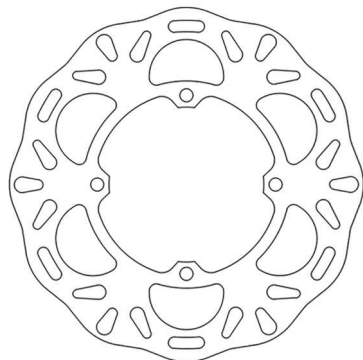
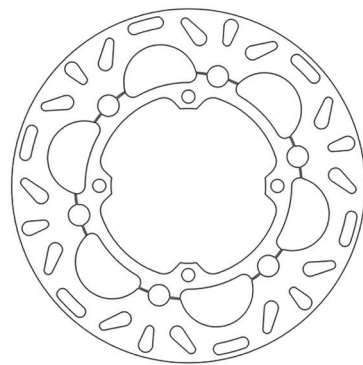

KAWASAKI	Year	A/P
KX 125	06->08	A
KX 250	06->08	A
KX F 250	06->14	A
KLX 450 R	08->20	A
KX F 450	06->14	A

**DF5137**

**AF**

**OE**

ØE:270 ØC:126 ØI:109,3 ØF:9,3 N°:4 SP:3

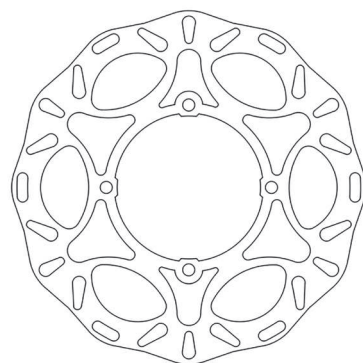
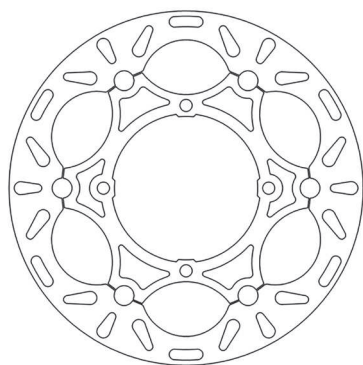

KAWASAKI	Year	A/P
KX 125	06->08	A
KX 250	06->08	A

FIGURATO DISCHI FRENO CON APPLICAZIONI | BRAKE DISCS DRAWINGS AND APPLICATIONS | DESSINS DISQUES DE FREIN AVEC APPLICATIONS | ZEICHNUNGEN VON BREMSSCHEIBEN MIT VERWENDUNGSLISTE | DISEÑOS DISCOS DE FRENO CON RELACION |





**...DF5137**

... segue <b>KAWASAKI</b>	Year	A/P
KX 250 (KX252)	20	A
KX F 250	06->14	A
KX F 250	15->19	A
KLX 450 R	08->20	A
KX F 450	06->14	A
KX F 450	15->20	A

**DF5139** **EF**

ØE:296 ØC:74 ØI:58,2 ØF:6,5 N°:6 SP:5 OS:23,90

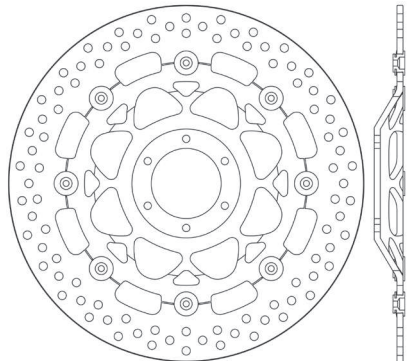

<b>HONDA</b>	Year	A/P
CB 600 F HORNET	00->06	A
CB 600 F HORNET S	00->04	A

**DF5145** **A**

ØE:200 ØC:120 ØI:100,4 ØF:6,3 N°:3 SP:3

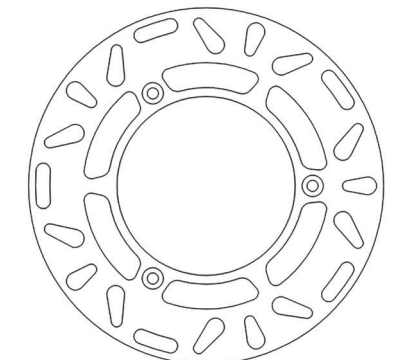

<b>SUZUKI</b>	Year	A/P
RM 80	90->01	A
RM 85	02->04	A

**DF5146** **A**

ØE:220 ØC:120 ØI:100,4 ØF:6,3 N°:3 SP:3

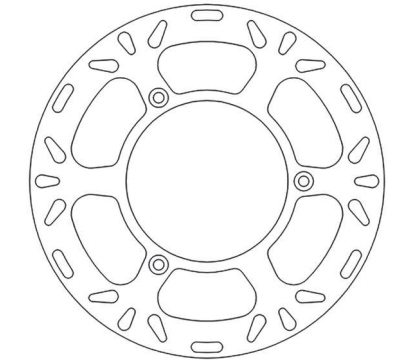

<b>SUZUKI</b>	Year	A/P
RM 85	05->07	A

<b>YAMAHA</b>	Year	A/P
YZ 65	18->20	A
YZ 80	93->01	A
YZ 85	02->20	A

**DF5147** **A**

ØE:180 ØC:95 ØI:79,3 ØF:9,3 N°:4 SP:3

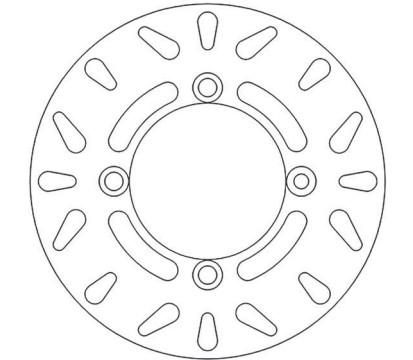

<b>KAWASAKI</b>	Year	A/P
KX 65	00->20	A / P

**DF5148** **A**

ØE:220 ØC:106 ØI:88,2 ØF:6,3 N°:4 SP:3

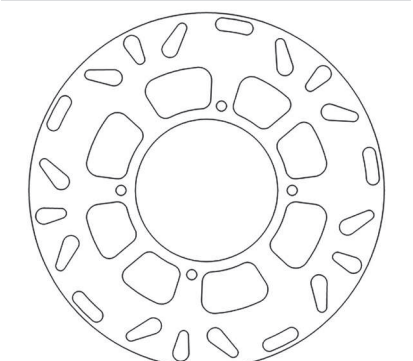

<b>HONDA</b>	Year	A/P
CR 80 R	97->02	A
CR 85	03->07	A
CRF 150 R	07->20	A

**DF5149** **AF**

ØE:240 ØC:106 ØI:88,2 ØF:6,3 N°:4 SP:3

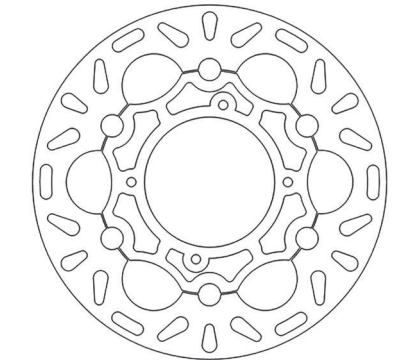

<b>HONDA</b>	Year	A/P
CR 85	03->07	A
CRF 150 R	07->20	A

**DF5150** **A**

ØE:190 ØC:94 ØI:80,2 ØF:6,3 N°:4 SP:3

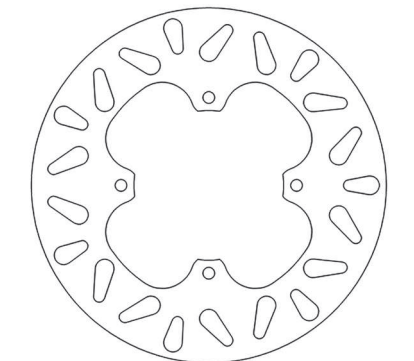

<b>HONDA</b>	Year	A/P
CR 80 R	97->02	P
CR 85	03->07	P
CRF 150 R	07->20	P

**DF5151** **A**

ØE:190 ØC:100 ØI:84,3 ØF:6,6 N°:4 SP:3

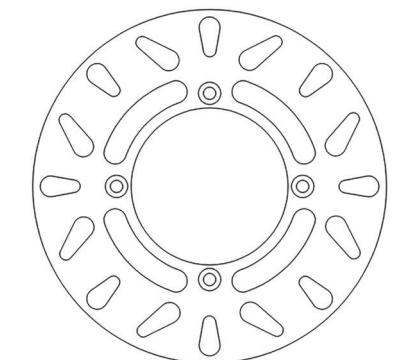

<b>YAMAHA</b>	Year	A/P
YZ 65	18->20	P
YZ 80	93->01	P
YZ 85	02->20	P

**DF5153**

**A**

ØE:305 ØC:203,7 ØI:180 ØF:8,5 N°:5 SP:5

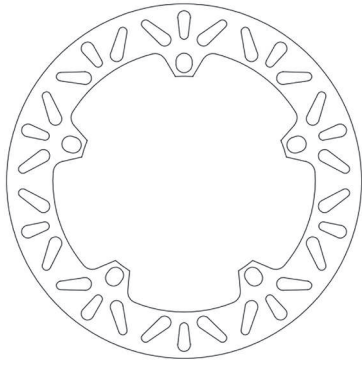

**DF5157**

**A**

ØE:200 ØC:99,5 ØI:84,2 ØF:6,5 N°:4 SP:3,5

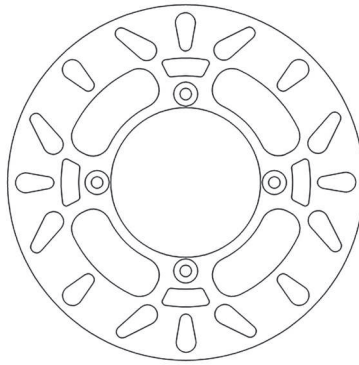

**DF5159**

**AF**

ØE:240 ØC:110 ØI:95 ØF:6,3 N°:4 SP:3

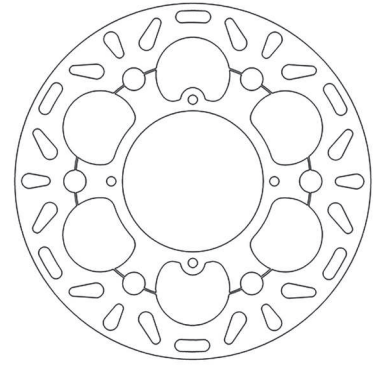

BMW	Year	A/P
R 850 C	97->01	A
R 850 GS	98->07	A
R 850 R (21_0145 - R28)	02->07	A
R 1100 GS	93->01	A
R 1100 S	96->00	A
R 1150 GS	00->03	A
R 1150 GS ADV	01->05	A
HP2 1200 ENDURO	05->09	A
K 1200 LT	97->01	A
K 1200 RS	96->00	A
R 1200 C	96->02	A
R 1200 C CLASSIC	03->04	A
R 1200 CL	02->06	A
R 1200 GS	03->07	A
R 1200 GS ADVENTURE	06->07	A

SUZUKI	Year	A/P
RM 85	05->07	P

**DF5158**

**A**

**AF**

ØE:220 ØC:110 ØI:95 ØF:6,3 N°:4 SP:3

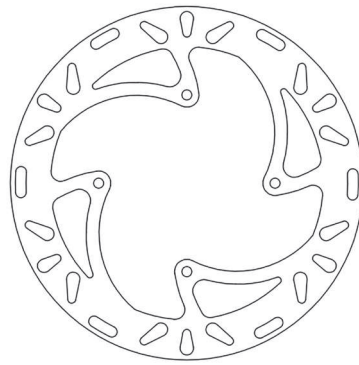

KTM	Year	A/P
SX 85	03->20	A
SXS 85	12->15	A
XC 85	07->09	A
SX 105	04->09	A
XC 105	08->10	A

**DF5160**

**A**

ØE:200 ØC:125 ØI:110 ØF:6,3 N°:4 SP:4

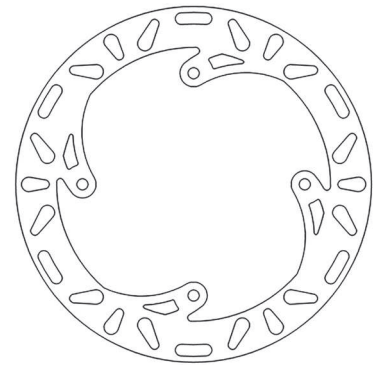

**DF5155**

**A**

ØE:240 ØC:125 ØI:107 ØF:8,6 N°:5 SP:5

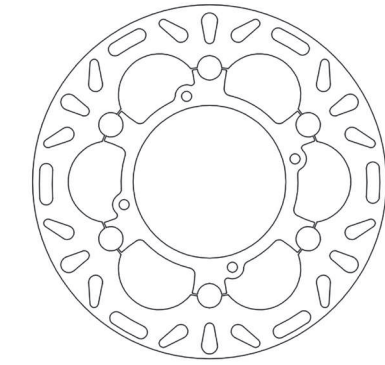
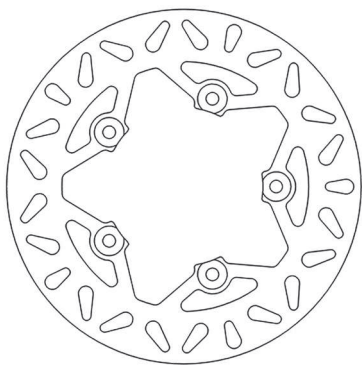

KTM	Year	A/P
SX 85	03->10	P
XC 85	07->09	P
SX 105	04->11	P
XC 105	08->10	P

**DF5161**

**AF**

ØE:250 ØC:120 ØI:100,4 ØF:6,3 N°:3 SP:3

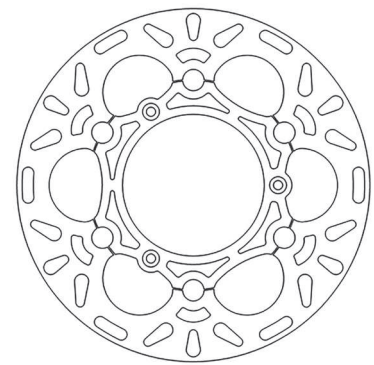

DUCATI	Year	A/P
749 (748cc)	03->06	P
749 DARK (748cc)	04->06	P
749 R (748cc)	04->06	P
749 S (748cc)	03->06	P
999 (998cc)	03->06	P
999 R (998cc)	03->06	P
999 RS (998cc) (con antisaltellamento)	04->05	P
999 S (998cc)	02->07	P

HUSQVARNA	Year	A/P
TC 85	14->20	A

KTM	Year	A/P
SX 85	03->20	A
SXS 85	12->15	A
XC 85	07->09	A
SX 105	04->11	A
XC 105	08->10	A

YAMAHA	Year	A/P
YZ 85	02->20	A

**FIGURATO DISCHI FRENO CON APPLICAZIONI | BRAKE DISCS DRAWINGS AND APPLICATIONS | DESSINS DISQUES DE FREIN AVEC APPLICATIONS |**  
**DISEÑOS DISCOS DE FRENO CON RELACION | ZEICHNUNGEN VON BREMSSCHEIBEN MIT VERWENDUNGSLISTE**



## DF5162

A AP

ØE:243,8 ØC:128 ØI:114 ØF:6,5 N°:4 SP:4,4

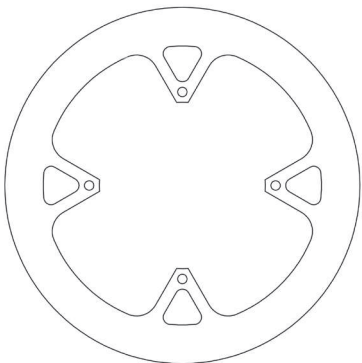
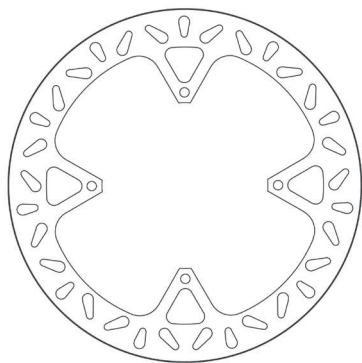

TM	Year	A/P
EN 125	01->14	P
MX 125	01->14	P
EN 144	14	P
EN 250	01->14	P
EN 250 F	01->14	P
MX 250	05->14	P
MX 250 F	05->14	P
all models 300	01->04	P
MX 300	05	P
MX 450 F	14	P
EN 530 F	05->14	P
MX 530 F 4T	05->14	P

## DF5163

A

ØE:317 ØC:206 ØI:184,2 ØF:10,8 N°:6 SP:7,5

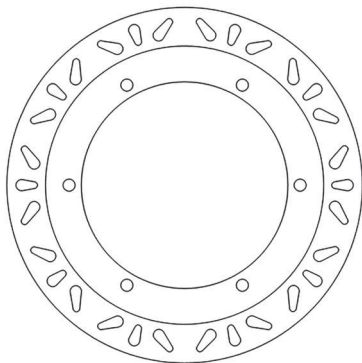

HONDA	Year	A/P
ST 1100 PAN EUROPEAN ABS	92->95	P
GL 1500 GOLDWING	90->00	P

## DF5164

A

ØE:290 ØC:124,3 ØI:108,5 ØF:6,5 N°:6 SP:3,5



HM	Year	A/P
CRE 50 DERAPAGE COMPETITION	07->11	A
CRE 50 DERAPAGE RR	07->09	A

## DF5169

A

ØE:220 ØC:125 ØI:105 ØF:10,5 N°:5 SP:5

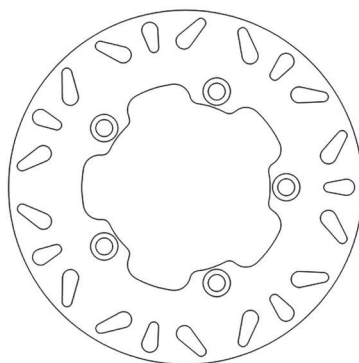

YAMAHA	Year	A/P
YZ-F 600 R6	03->20	P
MT-10 1000	16->20	P
YZ-F 1000 R1	04->20	P
YZ-F 1000 R1M	15->20	P

## DF5170

A

ØE:245 ØC:125 ØI:105 ØF:10,5 N°:5 SP:5

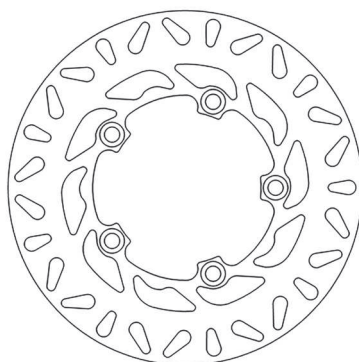

YAMAHA	Year	A/P
FZ6 600 FAZER	04->07	P
FZ6 600 FAZER ABS	06->07	P
FZ6 N 600	04->07	P
FZ6 NS 600	05->06	P
FZ6 S2 600	07->09	P
FZ6 S2 600 FAZER	07->09	P
FZ6 S2 600 FAZER ABS	08	P
MT-03 660	06->14	P
FZ1 1000	06->12	P
FZ1 1000 FAZER	06->12	P

## DF5173

A

ØE:250 ØC:100 ØI:84 ØF:8,2 N°:4 SP:6

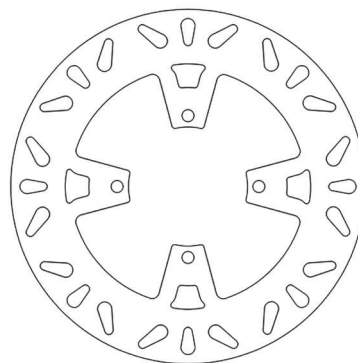

SUZUKI	Year	A/P
GSF 400 BANDIT	91->95	P
GS 500 E	89->95	P
GS 500 F	04->08	P
GSX 600 F KATANA	92->97	P
GSX 750 F	89->97	P

## DF5174

EF

ØE:300 ØC:81 ØI:62 ØF:10,7 N°:5 SP:6 OS:13,70

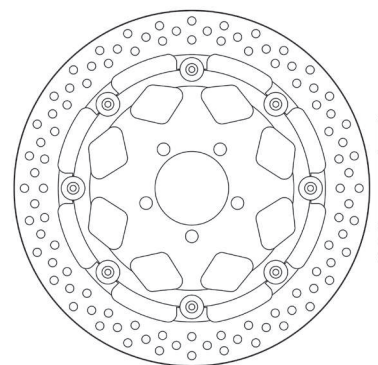

KAWASAKI	Year	A/P
ZZR 250	90->03	A
ZXR 400	89->90	A
ZZR 400	90->92	A
ZR 550 ZEPHYR	93->99	A
ZR 550 ZEPHYR (D from VIN B024010)	93->01	A
ZL 600 ELIMINATOR	95->99	A
ZX-6R 600 NINJA	94->02	A
ZZR 600	90->06	A
ZZR 600 (ZX E6F)	06->07	A
ZX-6R 636 NINJA	02	A
Z 750 J (ZR)	04->06	A
Z 750 S (ZR)	05->07	A
ZR 750 ZEPHYR	91->98	A
ZR-7 750	99->04	A
ZR-7S 750	01->04	A
GPZ 900 R	90->96	A
GPZ 900 R (ZX)	98->02	A
GTR 1000	94->06	A
Z 1000	03->06	A
GPZ 1100 (ZX 1100)	95->99	A
ZX-12R 1200 NINJA	04->06	A

**DF5176**

**A**

ØE:276 ØC:166 ØI:144,1 ØF:10,5 N°:6 SP:4

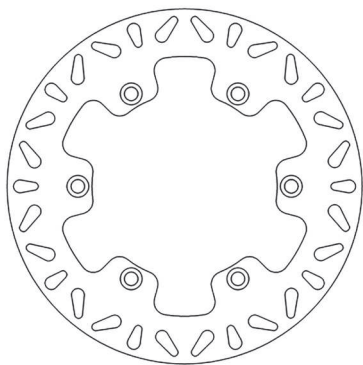

HONDA	Year	A/P
XBR 500	85->89	A
XL 600 VTRANSALP	87->96	A
SLR 650	97->98	A

**DF5177**

**A**

ØE:240 ØC:120 ØI:102,3 ØF:6,6 N°:5 SP:4

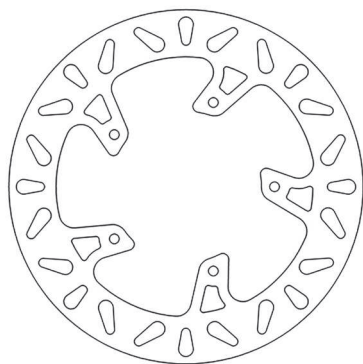

APRILIA	Year	A/P
RXV 450 4.5	05->	P
SXV 450	05->	P
RXV 550 5.5	05->	P
SXV 550	06->	P

**DF5178**

**A**

ØE:265 ØC:160 ØI:136,5 ØF:10,6 N°:5 SP:5

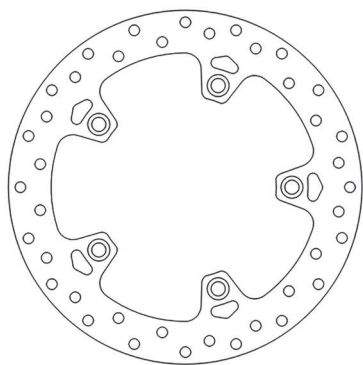

BMW	Year	A/P
F 650 GS	08->12	P
F 650 GS ABS	08->12	P
F 700 GS	13->17	P
F 800 GS	08->20	P
F 800 GS ADVENTURE	13->17	P
F 800 GT	13->20	P
F 800 R	09->14	P
F 800 S	06->10	P
F 800 ST	06->12	P

**...DF5178**

**... segue BMW**

Year	A/P
F 800 ST TOURING	11->12 P
HP2 1200 ENDURO	05->09 P
HP2 1200 MEGAMOTO	07->10 P
HP2 1200 SPORT	08->11 P
K 1200 R	05->11 P
K 1200 S	05->08 P
R 1200 GS	03->07 P
R 1200 GS ADVENTURE	06->07 P
R 1200 R	06->14 P
R 1200 RT	03->13 P
R 1200 S	04->07 P
R 1200 ST	05->07 P
K 1300 R	09->15 P
K 1300 R CARBON	12 P
K 1300 R DYNAMIC	11->15 P
K 1300 S	09->15 P
K 1300 S HP	12 P
K 1300 S SPORT	12 P

**HUSQVARNA**

Year	A/P
NUDA 900 ABS	11->13 P
NUDA R 900 ABS	11->13 P

**DF5186**

**A**

ØE:267 ØC:134 ØI:118 ØF:6,6 N°:6 SP:4

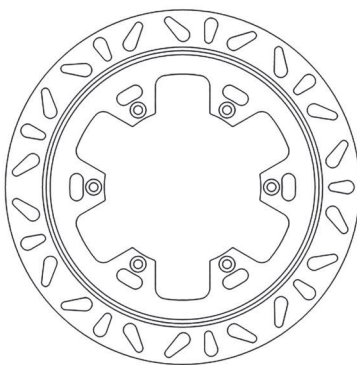

YAMAHA	Year	A/P
TT 600 K	93->96	A
TT E 600	93->01	A
TT R 600	98->02	A
TT R 600 E	04->07	A

**DF5187**

**AF**

ØE:300 ØC:120 ØI:105,1 ØF:6,6 N°:6 SP:5

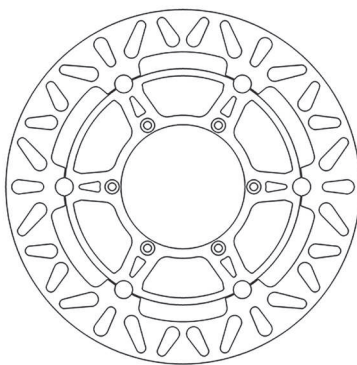

APRILIA	Year	A/P
PEGASO 125	89->99	A
PEGASO 600	89->91	A
PEGASO 650	91->96	A
PEGASO 650 3	97->00	A
PEGASO 650 IE	01->04	A
PEGASO 660 TRAIL	06->08	A

**DF5188**

**AF**

ØE:305 ØC:134 ØI:118,4 ØF:9 N°:6 SP:5

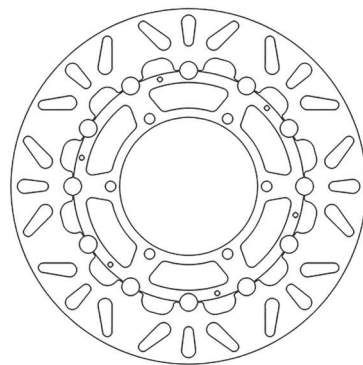

BMW	Year	A/P
R 850 R (21_0097 - 259R)	94->01	A
R 850 RT (21_0097 - 259T)	96->01	A
K 1 1000	88->93	A
K 100 RS 1000	89->92	A
K 1100 LT/SE	92->00	A
K 1100 RS	92->96	A
R 1100 R	93->01	A
R 1100 RS	92->01	A
R 1100 RT	94->01	A

**DF5189**

**A**

ØE:240 ØC:124 ØI:110 ØF:6,5 N°:6 SP:5

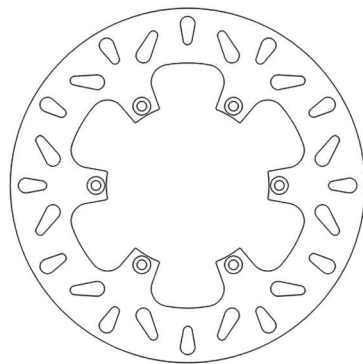

APRILIA	Year	A/P
PEGASO 650 IE	01->04	P
PEGASO 660 STRADA	05->09	P
PEGASO 660 TRAIL	06->08	P

BENELLI	Year	A/P
TNT 1100	04	P
TNT 1130	05->06	P
TNT 1130 CAFE RACER	05->06	P

BMW	Year	A/P
F 650	93->03	P
F 650 CS SCARVER	00->07	P
F 650 GS	99->07	P
G 650 GS	09->15	P

FIGURATO DISCHI FRENO CON APPLICAZIONI | BRAKE DISCS DRAWINGS AND APPLICATIONS | DESSINS DISQUES DE FREIN AVEC APPLICATIONS |  
DISEÑOS DISCOS DE FRENO CON RELACION | ZEICHNUNGEN VON BREMSSCHEIBEN MIT VERWENDUNGSLISTE

740

ØE **DIAM. ESTERNO**  
outside diam / diam extern /  
diam exterior / Außendurchmesser

ØC **DIAM. CIRCOLARE PASSANTE** / diam through  
the holes / diam entre trous / diám a través  
de los agujeros / Durchmesser durch die Löcher

ØI **DIAM. INTERNO**  
inside diam / diam intérieure /  
diam interior / Innendurchmesser





## DF5190

AF

ØE:300 ØC:120 ØI:105,1 ØF:6,6 N°:6 SP:5

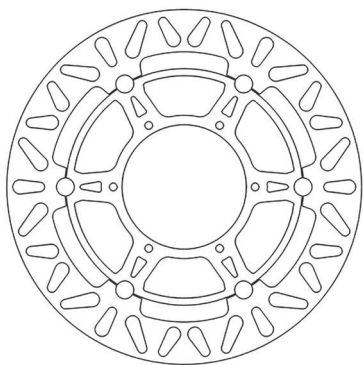

BMW	Year	A/P
F 650	93->03	A
F 650 CS SCARVER	00->07	A
F 650 GS	99->07	A
F 650 GS ABS	02->07	A
F 650 ST	96->00	A
F 650 ST STRADA	97->01	A
G 650 GS	09->15	A
G 650 X CHALLENGE	06->09	A
G 650 X COUNTRY	06->09	A
F 800 GS	08->20	A
F 800 GS ADVENTURE	13->17	A
HUSQVARNA	Year	A/P
TR 650 STRADA	13->14	A
TR 650 TERRA	13->14	A

## DF5192

A

ØE:296 ØC:206 ØI:184,7 ØF:10,5 N°:6 SP:6

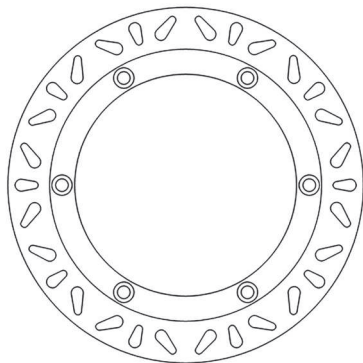

HONDA	Year	A/P
GL 1100	82->	A/P
GL 1100 DX	82->	A/P
GL 1500 GOLDWING	88->89	A
GLX 1500	88->	A

## DF5193

A

AF

ØE:198 ØC:104 ØI:89,3 ØF:6,3 N°:3 SP:3

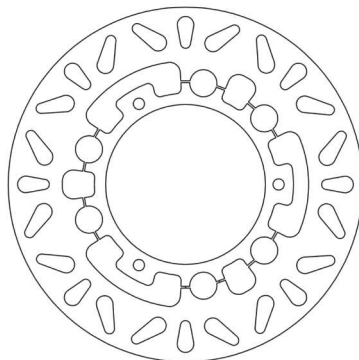
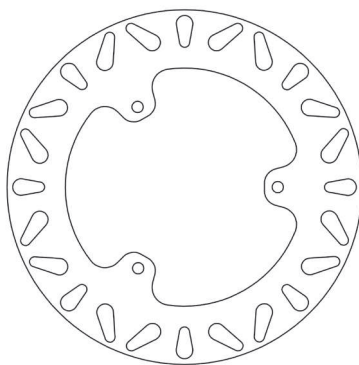

HUSQVARNA	Year	A/P
CR 65	10->14	A
TC 65	17->20	A
KTM	Year	A/P
SX 65	98->20	A
SXS 65	12->15	A
XC 65	08->09	A
MX 80	00->02	A

## DF5194

A

ØE:160 ØC:60 ØI:45,3 ØF:6,3 N°:4 SP:3

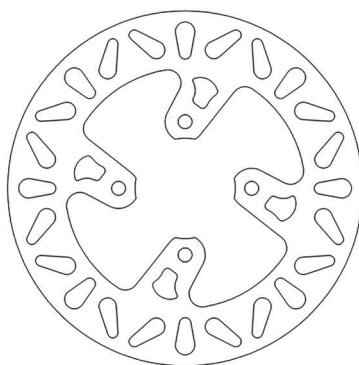

HUSQVARNA	Year	A/P
TC 65	17->20	P
TC 85	14->20	P
KTM	Year	A/P
SX 65	98->20	P
SXS 65	12->15	P
XC 65	08->09	P
MX 80	00->02	P

## DF5195

A

ØE:250 ØC:146 ØI:130,2 ØF:10,5 N°:9 SP:4

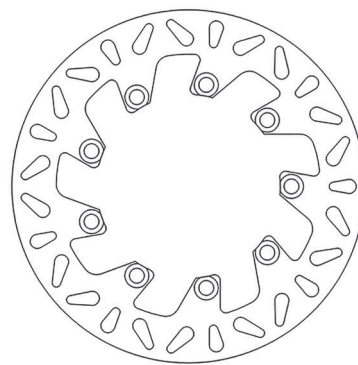

KAWASAKI	Year	A/P
KLR 570	84->91	A
KLR 600	84->86	A
KLR 600 ELECTRIC STARTER	85->94	A

## DF5196

A

ØE:260 ØC:150 ØI:130,2 ØF:10,5 N°:6 SP:5

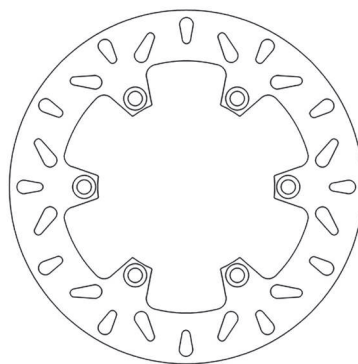

KAWASAKI	Year	A/P
EL 250	90->03	A
EX 250 NINJA	86->87	A
ZX-4 400	88->89	P
GPZ 750	83->87	P
GPZ 750 R	85->86	P
GPX 1000 R	88->	P

## DF5197

A

ØE:300 ØC:146 ØI:130,2 ØF:10,5 N°:9 SP:5

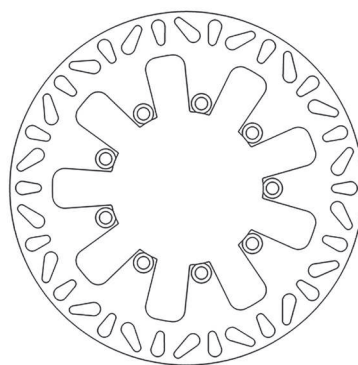

KAWASAKI	Year	A/P
KLE 500	91->07	A

**DF5198**

EF

ØE:296 ØC:74 ØI:58,3 ØF:6,5 N°:6 SP:5 OS:17,40

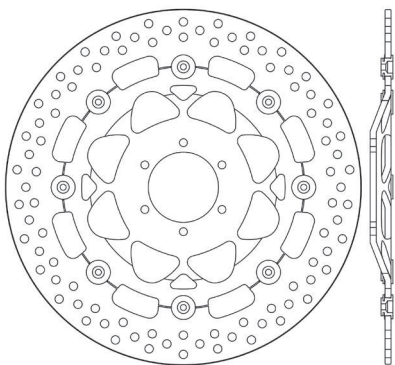

HONDA	Year	A/P
RS 125 R	91->95	A
CB 250 FT HORNET	96->01	A
RS 250	93->94	A
RS 250 R	91->97	A
CB 400 N - NA - NB	78->82	A
CB 400 N/F	83->	A
CBR 400 R HURRICANE	86	A
CBR 400 RR (GULLARM NC29)	90->94	A
CBR 400 RR (TRI ARM NC23)	87->89	A
VFR 400 R (NC 30)	89->92	A
CBR 600 F	95->98	A
VFR 750 F	94->97	A
CBR 900 RR FIREBLADE (918 cc)	95->97	A
VTR 1000 F FIRESTORM	97->07	A

**DF5199**

EF

ØE:310 ØC:81 ØI:61,2 ØF:10,5 N°:5 SP:5 OS:13,80

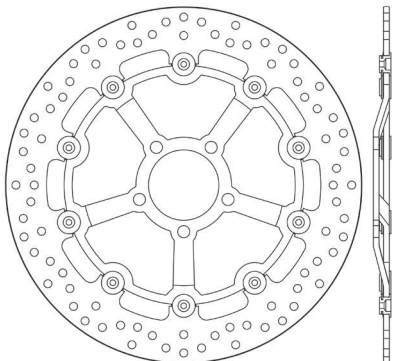

KAWASAKI	Year	A/P
ZXR 400 (ZX 400L) RR	92->02	A
ZXR 400 R	91->94	A
ZX-7R 750 NINJA	89->95	A
ZXR 750 R	91->95	A
ZX-9 900 R NINJA	00->01	A
ZR 1100 ZEPHYR (ZR 1100 A)	92->98	A
ZRX 1100 C1	99->00	A
ZZR 1100 GT (ZX 1100)	90->92	A
ZRX 1200 R - S	01->08	A

**DF5202**

EF

ØE:300 ØC:86 ØI:64,2 ØF:10,5 N°:5 SP:5 OS:19,50

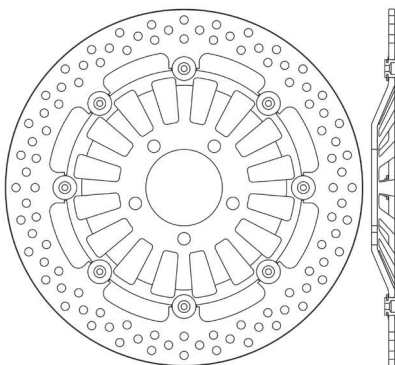

SUZUKI	Year	A/P
RG 125 T - FV	92->94	A
RGV 250	93->95	A
RGV 250 GAMMA	91->92	A
VZ 800 MARAUDER	97->03	A
GSX 1200 X	99->01	A
GV 1200 GL MADURA	85->86	A

**DF5205**

EF

ØE:296 ØC:78 ØI:62,2 ØF:6,5 N°:6 SP:5 OS:22,60

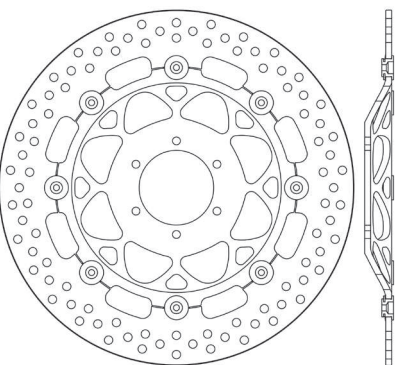

HONDA	Year	A/P
CB 400 FOUR	97->98	A
CB-1 400 F	89->90	A
CB 600 F HORNET	98->99	A

**DF5210**

A

ØE:296 ØC:166 ØI:144 ØF:10,5 N°:6 SP:4

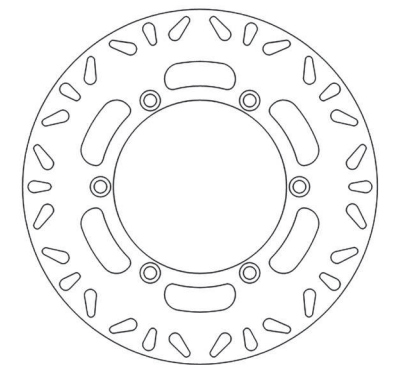

CAGIVA	Year	A/P
CANYON 500	96->00	A
CANYON 600	95->99	A
ELEFANT 750	93->95	A
ELEFANT 900 I.E.- GT - AC	91->94	A
GRAN CANYON 900	99->04	A
NAVIGATOR 1000	00->05	A

HONDA	Year	A/P
XRV 650 AFRICA TWIN	88->90	A

**DF5211**

EF

ØE:296 ØC:110 ØI:94,1 ØF:6,3 N°:6 SP:5 OS:14,60

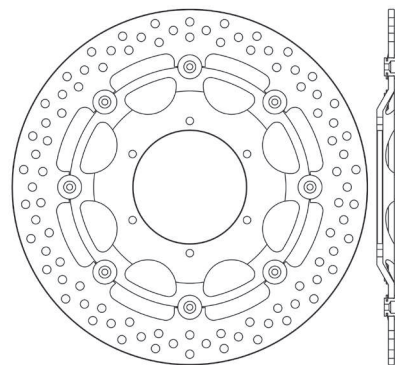

HONDA	Year	A/P
CB 600 F HORNET	07->13	A
CB 600 F HORNET ABS	07->08	A
CBR 600 F	11->13	A

**DF5213**

EFV

ØE:320 ØC:100,5 ØI:78,2 ØF:10,5 N°:5 SP:5 OS:14,50

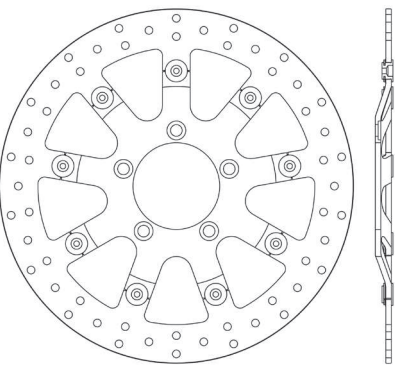

TRIUMPH	Year	A/P
DAYTONA i 955	03->06	A
DAYTONA i 955 BIBRACCIO	01->02	A
DAYTONA i 955 CENTENNIAL	02->04	A
SPEED TRIPLE i 955 955i VIN 141872 to 210444	02->06	A
SPRINT ST 1050 VIN 208167 up	05->10	A

FIGURATO DISCHI FRENO CON APPLICAZIONI | BRAKE DISCS DRAWINGS AND APPLICATIONS | DESSINS DISQUES DE FREIN AVEC APPLICATIONS |  
DISEÑOS DISCOS DE FRENO CON RELACION | ZEICHNUNGEN VON BREMSSCHEIBEN MIT VERWENDUNGSLISTE



**DF5214**
**EF**

ØE:320 ØC:80 ØI:64,1 ØF:8,5 N°:6 SP:5 OS:15

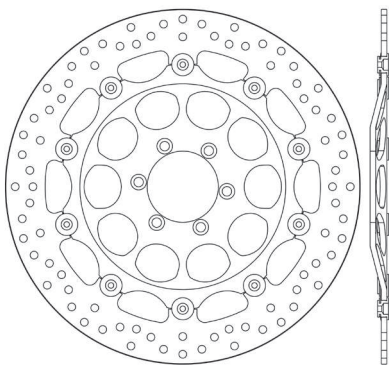

DUCATI	Year	A/P
748 R	01->02	A
996	99->01	A
996 R	01	A
998 R - S	02->03	A

**DF5215**
**A**

ØE:280 ØC:142 ØI:121,2 ØF:10,5 N°:4 SP:4

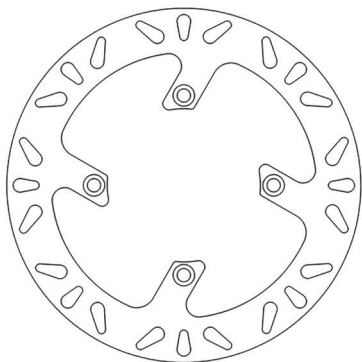

SUZUKI	Year	A/P
DR 650 RS-R DAKAR	90	A
DR 750 S BIG	87->88	A
DR 800 BIG S - SU	90	A
DR 800 Z	88->89	A

**DF5216**
**A**

ØE:220 ØC:124 ØI:110,3 ØF:6,5 N°:6 SP:5

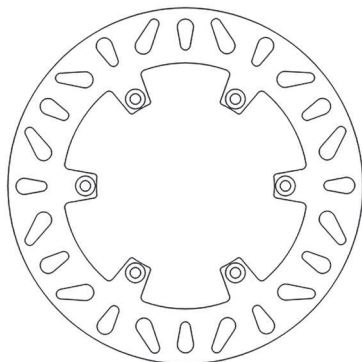

APRILIA	Year	A/P
MX 125	04->08	P
PEGASO 125	89->99	P
RS 125	95	P
RX 125	90	P
TUAREG 125 RALLY	89->92	P
PEGASO 600	89->91	P
MOTO 650 6.5	95->00	P
PEGASO 650	91->96	P
PEGASO 650 3	97->00	P

**DF5217**
**A**

ØE:220 ØC:110 ØI:88 ØF:10,5 N°:3 SP:4

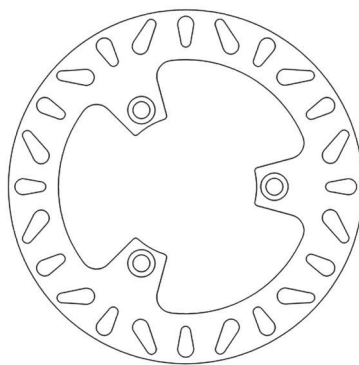

HONDA	Year	A/P
CBR 400 R HURRICANE	86	P
NS 400 R	85->87	P
VFR 400 R	85->86	P
CBR 600 F	87->90	P

**DF5218**
**A**

ØE:280 ØC:150 ØI:130,2 ØF:10,5 N°:6 SP:5

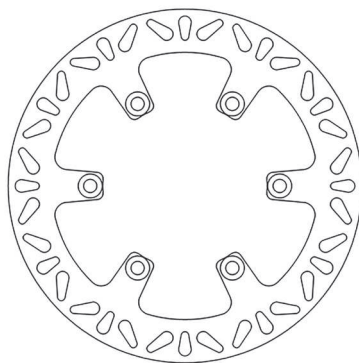

KAWASAKI	Year	A/P
ZL 400 ELIMINATOR	88	A
ER-5 500 TWISTER	97->07	A
GPZ 500 S	87->88	A
ZL 600	85->94	A
ZX 750 TURBO	84->87	A
GPZ 900 R	84->89	A
ZL 900 ELIMINATOR	85->86	A
GPX 1000 R	88->	A
GTR 1000	94->06	P

**DF5219**
**A**

ØE:256 ØC:110 ØI:94 ØF:8,5 N°:4 SP:5

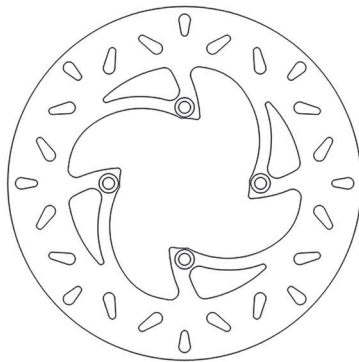

HONDA	Year	A/P
VFR 750 F	90->97	P
VFR 800 FI	98->02	P

**DF5221**
**A**

ØE:240 ØC:120 ØI:100,1 ØF:10,5 N°:4 SP:4

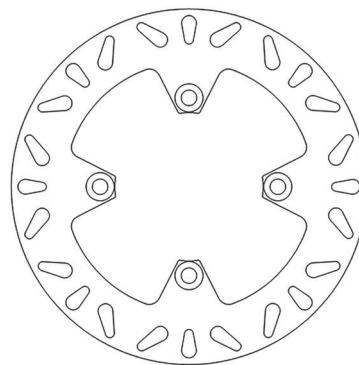

KAWASAKI	Year	A/P
ZXR 400	89->90	P
ZXR 400 (ZX 400L) RR	92->02	P
ZXR 400 R	91->94	P
ZR 550 ZEPHYR	93->99	P
ZR 550 ZEPHYR (D from VIN B024010)	93->01	P
ZZR 600	93->06	P
ZZR 600 (ZX E6F)	06->07	P
GPX 750	87->89	P
ZR-7 750	99->04	P
ZR-7S 750	01->04	P

**DF5222**
**A**

ØE:230 ØC:136 ØI:120 ØF:10,5 N°:6 SP:4

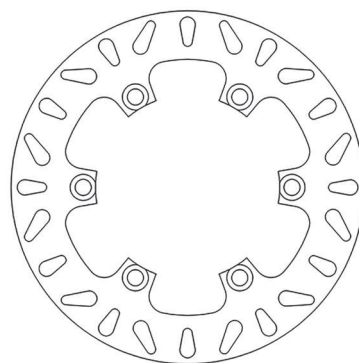

KAWASAKI	Year	A/P
KLE 500	91->07	P
KL 650 TENGAJ	89->92	P
KLR 650	87->04	P

**DF5223**
**A**

ØE:230 ØC:120 ØI:100,1 ØF:10,5 N°:4 SP:5

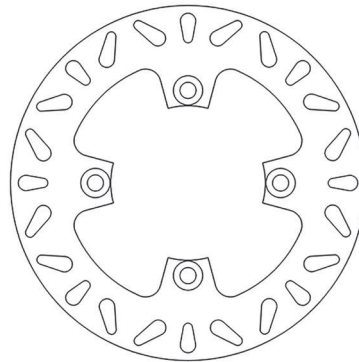

KAWASAKI	Year	A/P
ZX-12R 1200 NINJA	00->06	P

**DF5224**

**AF**

ØE:298 ØC:150 ØI:132,2 ØF:8,5 N°:6 SP:5

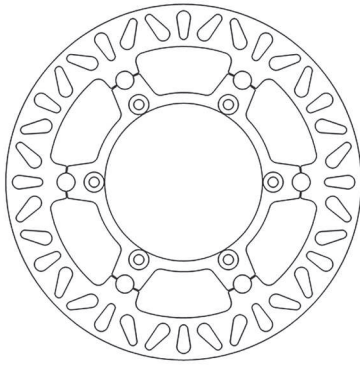

**DF5229**

**EF**

ØE:290 ØC:91 ØI:69,2 ØF:10,5 N°:5 SP:5

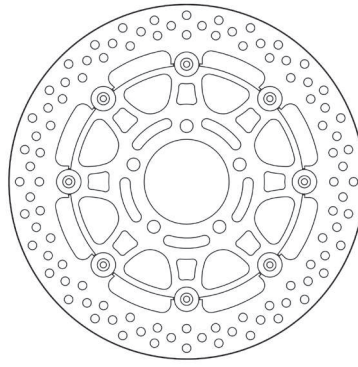

**DF5233**

**EF**

ØE:310 ØC:101,5 ØI:80 ØF:8,6 N°:5 SP:5 OS:10

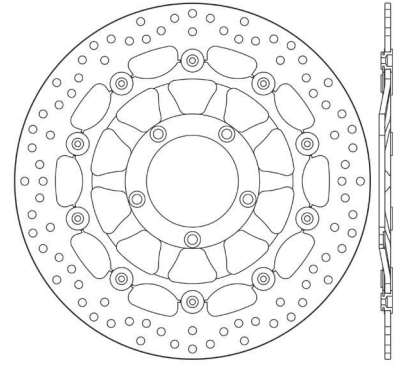

YAMAHA	Year	A/P
XV 535 DX VIRAGO	01->03	A
XV 535 VIRAGO	95->01	A
XVS 650 A DRAG STAR CLASSIC	98->07	A
XVS 650 DRAG STAR	97->04	A
XV 1100 VIRAGO	99->00	A
XVS 1100 A DRAG STAR CLASSIC	00->06	A
XVS 1100 DRAG STAR	99->04	A
XVZ 1200 12 TD	88->	A
XVS 1300 A MIDNIGHT STAR	07->11	A
XVZ 1300 ROYAL STAR	96->00	A
XVZ 1300 TF ROYAL STAR VENTURE	00	A
XV 1600 ROAD STAR SILVERADO	99->02	A
XV 1600 WILD STAR SILVERADO	99->04	A
XV 1670 ROYALS STAR WARRIOR	02->07	A
XV 1700 PC ROAD STAR WARRIOR	03->05	A
XV 1700 WARRIOR	03->04	A
XV 1900 A MIDNIGHT STAR	06->12	A

SUZUKI	Year	A/P
GSX 600 F	04->06	A
GSF 650 BANDIT	05->06	A
GSF 650 BANDIT ABS	05->06	A
SV 650	03->18	A
SV 650 S	03->18	A
GSX 750 F	03->06	A

MV AGUSTA	Year	A/P
BRUTALE 750 S	03->05	A
BRUTALE 750 SERIE ORO	03->05	A
F4 750 S - S 1+1	98->04	A
F4 750 SERIE ORO	98->04	A
BRUTALE 910	05->08	A
BRUTALE 910 R	05->08	A
BRUTALE 910 S	05->08	A
BRUTALE 920	11->14	A
BRUTALE 989 S	08->09	A
F4 1000	04->06	A

**DF5231**

**A**

ØE:245 ØC:124,3 ØI:107,3 ØF:8,6 N°:4 SP:5

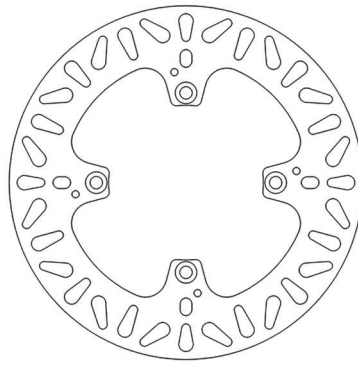

**DF5240**

**EF**

ØE:300 ØC:80 ØI:64,2 ØF:8,6 N°:6 SP:5

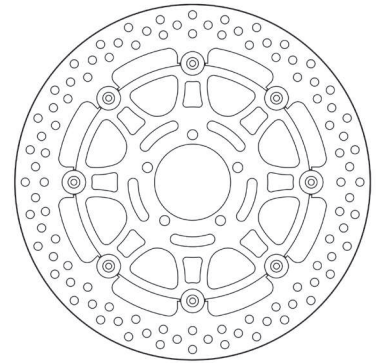

**DF5227**

**A**

ØE:250 ØC:120 ØI:100,5 ØF:10,5 N°:5 SP:5

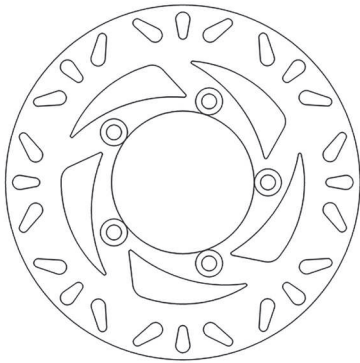

KAWASAKI	Year	A/P
ZRX 1100 C1	97->00	P
ZRX 1200 R - S	01->08	P

DUCATI	Year	A/P
MONSTER 795	13	P
HYPERMOTARD 796 (800cc)	10->12	P
MONSTER 796 (800cc)	11->14	P
MONSTER 800 S2R	05->07	P
MONSTER 800 S2R DARK	05->06	P
848 848	08->10	P
848 848 EVO	11->12	P
STREETFIGHTER 848	12	P
STREETFIGHTER 848 S	12	P
MONSTER 996 S4R	03->06	P
MONSTER 1000 S2R	06->08	P
MONSTER 1000 S4R	07->08	P
MONSTER 1000 S4RS	06->08	P
MONSTER 1000 S4RS TRICOLORE	08	P
MULTISTRADA 1000	03->06	P
MULTISTRADA 1000 DS	05	P
MULTISTRADA 1000 DS S	05	P
MULTISTRADA 1000 S	06	P
HYPERMOTARD 1100	07->09	P
HYPERMOTARD 1100 EVO	10->12	P
HYPERMOTARD 1100 EVO SP	10->12	P
HYPERMOTARD 1100 S	07->09	P
MONSTER 1100	09->10	P
MONSTER 1100 DIESEL	13	P
MONSTER 1100 EVO	12->13	P
MONSTER 1100 EVO - EVO ABS	12->13	P
MONSTER 1100 EVO ANNIVERSARY	13	P
MONSTER 1100 S	09->10	P
MULTISTRADA 1100	07->09	P
MULTISTRADA 1100 S	07->09	P

DUCATI	Year	A/P
MONSTER 620	05->06	A
MONSTER 620 DARK	05->06	A
MULTISTRADA 620	06	A
MONSTER 695	07->08	A
MONSTER 800 S2R	05->07	A
MONSTER 800 S2R DARK	05->06	A
MONSTER 1000 S2R	06->08	A

**FIGURATO DISCHI FRENO CON APPLICAZIONI | BRAKE DISCS DRAWINGS AND APPLICATIONS | DESSINS DISQUES DE FREIN AVEC APPLICATIONS |**  
**DISEÑOS DISCOS DE FRENO CON RELACION | ZEICHNUNGEN VON BREMSSCHEIBEN MIT VERWENDUNGSLISTE**





**DF5248** EFV

ØE:310 ØC:100,4 ØI: 84,3 ØF:10,6 N°:5 SP:5 OS:14,10

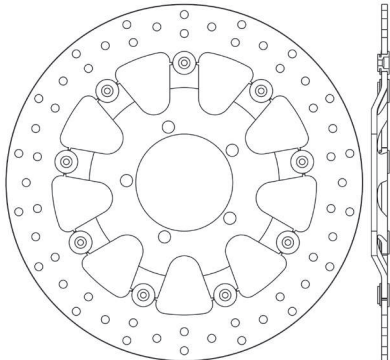

TRIUMPH	Year	A/P
DAYTONA 675 up to VIN 381274	06->08	A
DAYTONA TRIPLE 675	09->12	A
DAYTONA TRIPLE R 675	11->12	A
STREET TRIPLE 675	08->12	A
STREET TRIPLE R 675	09->12	A
TIGER XC 800	15->17	A

**DF5249** EF

ØE:305 ØC:90 ØI: 72,1 ØF:8,6 N°:5 SP:5 OS:10

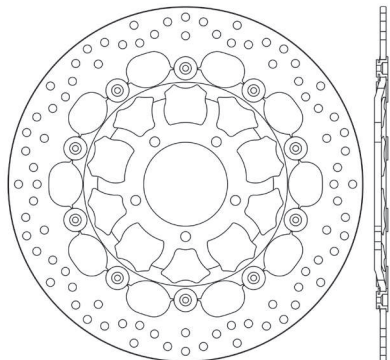

DUCATI	Year	A/P
HYPERMOTARD 796 (800cc)	10->12	A
HYPERMOTARD 1100	07->09	A
HYPERMOTARD 1100 EVO	10->12	A
HYPERMOTARD 1100 EVO SP	10->12	A
HYPERMOTARD 1100 S	07->09	A

**DF5254** A

ØE:245 ØC:132,9 ØI: 115 ØF:8,6 N°:5 SP:5

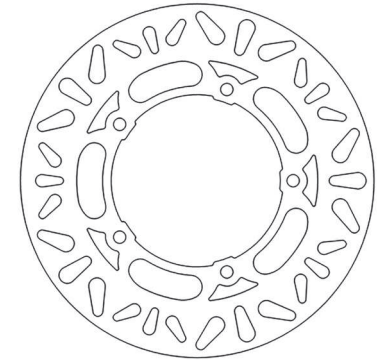

YAMAHA	Year	A/P
XJ6 600 DIVERSION	09->15	P
XJ6 F 600 DIVERSION	09->16	P
XJ6 N 600 DIVERSION	09->16	P
XJ6 S 600 DIVERSION	09->15	P

**DF5256** A

ØE:245 ØC:134,3 ØI: 115,3 ØF:6,5 N°:6 SP:4

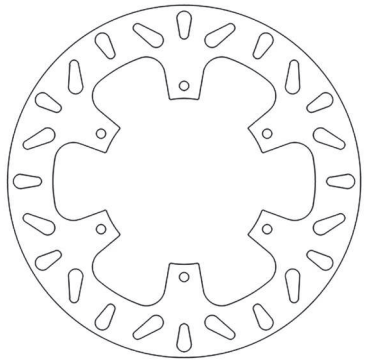

YAMAHA	Year	A/P
TZR 50	93->95	A
XTZ 750 SUPER TENERE	89->95	A

**DF5261** A

ØE:255 ØC:166 ØI: 144,3 ØF:10,4 N°:5 SP:5

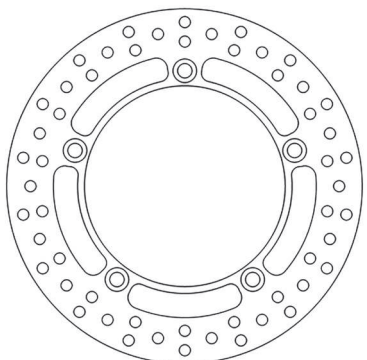

TRIUMPH	Year	A/P
TIGER 885 up to VIN 71698	93->98	P

**DF5262** A AV

ØE:254,5 ØC:125,2 ØI: 105 ØF:10,5 N°:4 SP:5

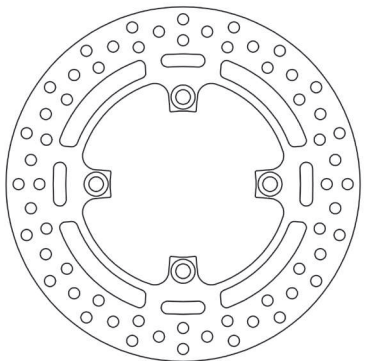
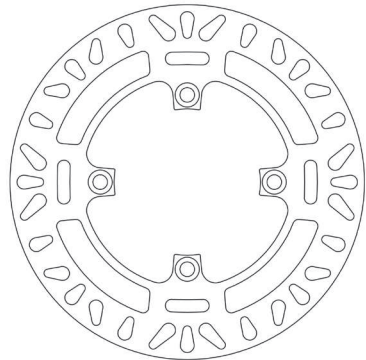

TRIUMPH	Year	A/P
BONNEVILLE 790 (carb) T100 up to Eng No 211132	02->04	P
BONNEVILLE 790 (carb) Up to Eng No 282963-F2 / 273654-F4	01->06	P
TIGER 800	11->14	P
TIGER XC 800	11->14	P
BONNEVILLE 865 (carb) T100 Eng No 211133 up	05->11	P
BONNEVILLE 865 EFI (ALLOY WHEELS) VIN 380777 up	09->15	P
BONNEVILLE 865 EFI T100	12->17	P
BONNEVILLE 865 Eng No 282964-F2 / 273655-F4 up	07->08	P
BONNEVILLE SE 865 EFI (ALLOY WHEELS) VIN 380777 up	09->12	P
SCRAMBLER 865 (carb)	06->08	P
SCRAMBLER 865 EFI	12->18	P
THRUXTON 865 (carb)	04->07	P
THRUXTON 865 EFI	12->16	P
SPRINT RS 955 FROM VIN 139277	02->05	P
SPRINT RS 955 up to VIN 139276	00->01	P
SPRINT ST 955 up to VIN 139276	99->01	P
SPRINT ST 955 VIN 139277 TO VIN 208166	02->04	P
SPEED TRIPLE 1050	11->18	P
SPEED TRIPLE R 1050	12->18	P
SPRINT ST 1050 VIN 208167 up	05->10	P
TIGER 1050	07->13	P

**DF5263**

**AFV**

ØE:310 ØC:166 ØI:144,4 ØF:10,5 N°:6 SP:5,5

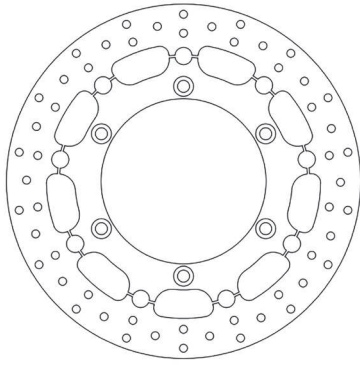

TRIUMPH	Year	A/P
BONNEVILLE 790 (carb) T100 up to Eng No 211132	02->04	A
BONNEVILLE 790 (carb) Up to Eng No 282963-F2 / 273654-F4	01->06	A
BONNEVILLE 790 AMERICA (carb)	02->04	A
SPEEDMASTER 790 (carb)	03->04	A
AMERICA 865 (carb)	05->11	A
AMERICA 865 EFI	12->18	A
BONNEVILLE 865 (carb) T100 Eng No 211133 up	05->11	A
BONNEVILLE 865 EFI T100	12->17	A
BONNEVILLE 865 Eng No 282964-F2 / 273655-F4 up	07->08	A
SCRAMBLER 865 (carb)	06->08	A
SCRAMBLER 865 EFI	12->18	A
SPEEDMASTER 865 (carb)	05->10	A
THUNDERBIRD 885 SPORT	03->04	A
SPRINT RS 955 FROM VIN 139277	02->05	A
SPRINT ST 955 VIN 139277 TO VIN 208166	02->04	A

**DF5264**

**AFV**

ØE:320 ØC:166 ØI:144 ØF:10,5 N°:6 SP:5

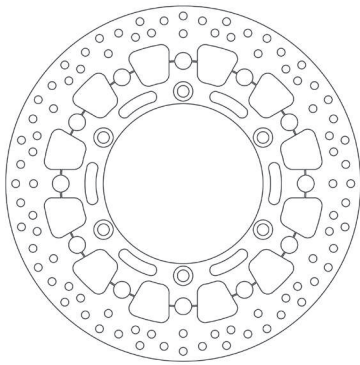

TRIUMPH	Year	A/P
THRUXTON 865 (carb)	04->07	A
THRUXTON 865 EFI	12->16	A
ADVENTURER 885	96->01	A
LEGEND TT 885	99->01	A
THUNDERBIRD 885	95->05	A

SUZUKI	Year	A/P
DL 650 V STROM	04->06	P
DL 650 V STROM X	04->12	P
DL 1000 V STROM	02->13	P

**DF5266**

**A**

**AV**

ØE:285 ØC:166,3 ØI:144,4 ØF:10,3 N°:5 SP:6

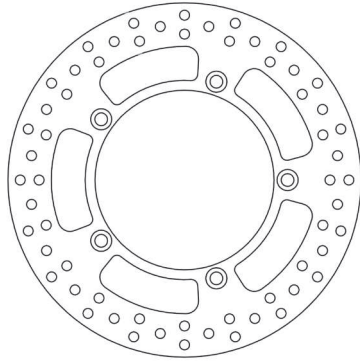
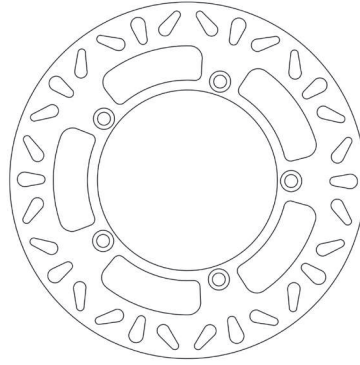

TRIUMPH	Year	A/P
BONNEVILLE 790 AMERICA (carb)	02->04	P
SPEEDMASTER 790 (carb)	03->04	P
AMERICA 865 (carb)	05->11	P
AMERICA 865 EFI	12->18	P
SPEEDMASTER 865 (carb)	05->10	P
SPEEDMASTER 865 EFI	11->17	P
ADVENTURER 885	96->01	P
LEGEND TT 885	99->01	P
THUNDERBIRD 885	95->05	P
THUNDERBIRD 885 SPORT	03->04	P

**DF5269**

**A**

ØE:260 ØC:161,9 ØI:141,1 ØF:10,3 N°:4 SP:5

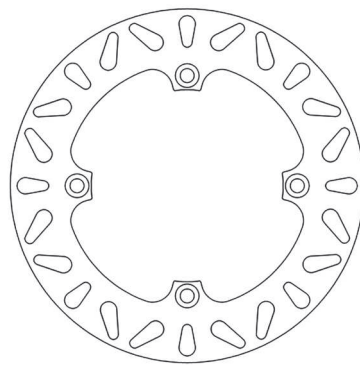

KAWASAKI	Year	A/P
KL V 1000	04->07	P

SUZUKI	Year	A/P
DL 650 V STROM	04->06	P
DL 650 V STROM X	04->12	P
DL 1000 V STROM	02->13	P

**DF5273**

**A**

ØE:220 ØC:120,2 ØI:100,3 ØF:10,7 N°:4 SP:5

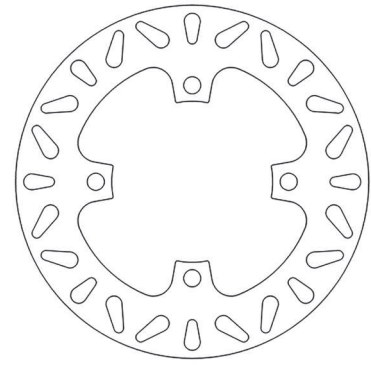

KAWASAKI	Year	A/P
ZX-10R 1000 NINJA	11->15	P

**DF5274**

**AF**

ØE:290 ØC:142,1 ØI:122 ØF:10,4 N°:5 SP:4,5

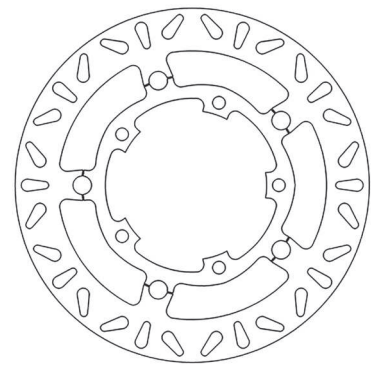

SUZUKI	Year	A/P
SFV 650 GLADIUS	09->16	A
SV 650 ABS	07->18	A

**DF5275**

**A**

ØE:240 ØC:141 ØI:120,1 ØF:10,4 N°:5 SP:5

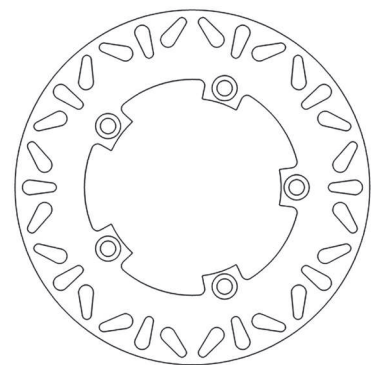

SUZUKI	Year	A/P
GSR 600	06->08	P
GSF 650 BANDIT	05->06	P
GSF 650 BANDIT ABS	05->12	P
GSF 650 S BANDIT ABS	07->13	P
GSX 650 F	08->16	P
SFV 650 GLADIUS	09->16	P
SV 650 ABS	07->18	P
GSR 750	11->16	P
GSF 1200 BANDIT	06->09	P
GSF 1200 S BANDIT	06	P
GSF 1250 BANDIT	07->12	P
GSX 1250 FA	10->12	P

FIGURATO DISCHI FRENO CON APPLICAZIONI | BRAKE DISCS DRAWINGS AND APPLICATIONS | DESSINS DISQUES DE FREIN AVEC APPLICATIONS | DISEÑOS DISCOS DE FRENO CON RELACION | ZEICHNUNGEN VON BREMSSCHEIBEN MIT VERWENDUNGSLISTE



**DF5276**
**A**

ØE:240 ØC:135 ØI:116,8 ØF:10,7 N°:4 SP:5

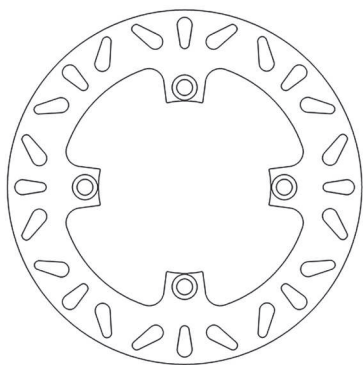

HONDA	Year	A/P
CBF 500	04->07	P
CBF 500 ABS	04->07	P
CB 600 F HORNET	07->13	P
CB 600 F HORNET ABS	07->08	P
CBF 600	04->07	P
CBF 1000 ABS	06->11	P
CBR 1000 F BIG ONE	93->97	P

**DF5277**
**EFV**

ØE:320 ØC:166 ØI:149 ØF:10,6 N°:5 SP:4,5

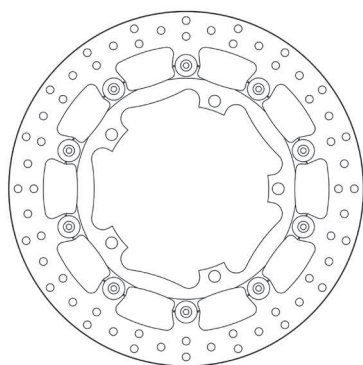

TRIUMPH	Year	A/P
SPEED TRIPLE 1050	08->18	A
SPEED TRIPLE R 1050	12->18	A
SPEED TRIPLE S 1050	16->20	A
SPRINT GT 1050	11->15	A
SPRINT GT 1050 ABS	11->18	A
TROPHY SE 1215	12->18	A

**DF5282**
**A**

ØE:210 ØC:125,1 ØI:109 ØF:6,3 N°:4 SP:4

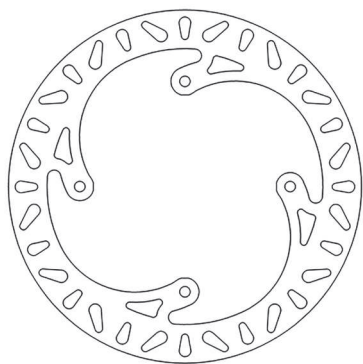

KTM	Year	A/P
SX 85	11->20	P
SXS 85	12->15	P

**DF5284**
**A**

ØE:220 ØC:108 ØI:88,7 ØF:8,6 N°:5 SP:5

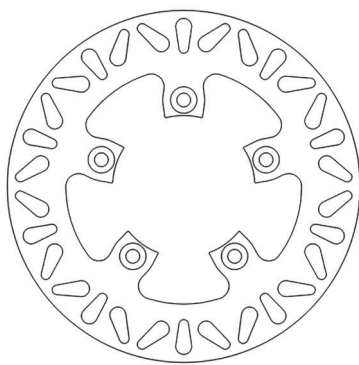

KTM	Year	A/P
RC8 1190	08->11	P
RC8 1190 R	09->15	P
RC8 1190 R TRACK	11->15	P

**DF5288**
**A**

ØE:240 ØC:130 ØI:112,6 ØF:9,5 N°:4 SP:4

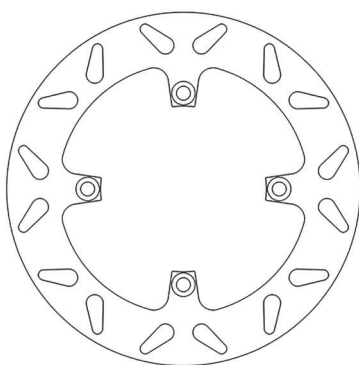

HUSQVARNA	Year	A/P
CR 125	05->13	P
WR 125	06->13	P
CR 250	05->13	P
TC 250	02->13	P
TXC 250	10->13	P
WR 250	07->13	P
TE 310 4T	10->13	P
TXC 310	11->13	P
SMR 449	11->	P
TC 449	11->13	P
TE 449	11->13	P
SM 450 RR	06->	P
TC 450	04->10	P
TE 450	02->10	P
SM 510 R	05->	P
TC 510	04->10	P
TE 510	05->10	P
SMR 511	11->	P
TE 511	11->13	P

**DF5291**
**A**

ØE:260 ØC:190 ØI:171,8 ØF:9,8 N°:6 SP:3,3

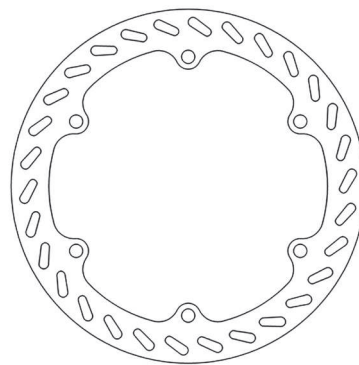

TM	Year	A/P
all models 80 (solo fascia frenante)	94->03	A
all models 85 (solo fascia frenante)	98->03	A

**DF5292**
**EFV**

ØE:310 ØC:100,6 ØI:78,3 ØF:10,7 N°:5 SP:5,5

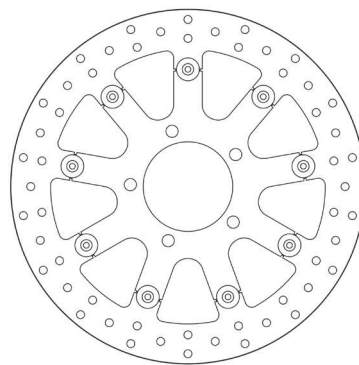

TRIUMPH	Year	A/P
BONNEVILLE 865 EFI (ALLOY WHEELS) VIN 380777 up	09->15	A
BONNEVILLE SE 865 EFI (ALLOY WHEELS) VIN 380777 up	09->12	A
SPEEDMASTER 865 EFI	11->17	A

**DF5296**

A | AF | OE

ØE:260 ØC:117 ØI:101,3 ØF:6,5 N°:6 SP:3

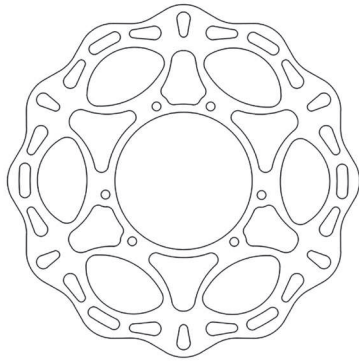
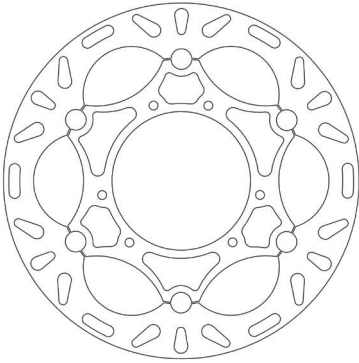
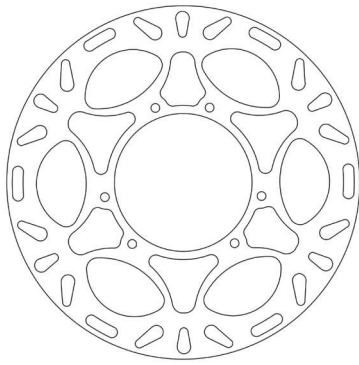

HONDA	Year	A/P
CRF 250 R - E	15->20	A
CRF 450 R - E	15->20	A
CRF 450 RX	17->19	A
CRF 450 X	15->20	A

**DF5297**

A

ØE:220 ØC:136 ØI:119,7 ØF:6,5 N°:5 SP:5

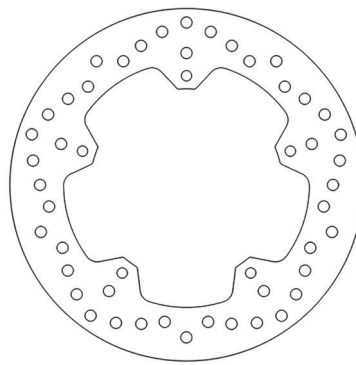

BMW	Year	A/P
S 1000 R	13->19	P
S 1000 RR	09->18	P
S 1000 RR HP4	13->14	P

**DF5303**

EF

ØE:300 ØC:100 ØI:80,1 ØF:10,6 N°:5 SP:5

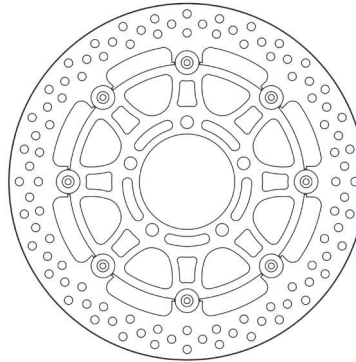

KAWASAKI	Year	A/P
ZX-6 RR 600 NINJA	03->06	A
ZX-6R 600 NINJA	07->12	A
ZX-6R 636 NINJA	05->06	A
ER - 6F 650	06->16	A
ER - 6F 650 ABS	06->12	A
ER - 6N 650	06->16	A
ER - 6N 650 ABS	06->12	A
KLE 650 VERSYS	07->17	A
KLE 650 VERSYS ABS	07->14	A
Z 750	07->12	A
Z 750 R	11->12	A
Z 750 R ABS	11->12	A
Z 1000	07->13	A
Z 1000 ABS	15->19	A
Z 1000 SX	11->19	A
ZX-10R 1000 NINJA	04->07	A

**DF5304**

EF

ØE:310 ØC:120 ØI:102,2 ØF:8,6 N°:6 SP:5

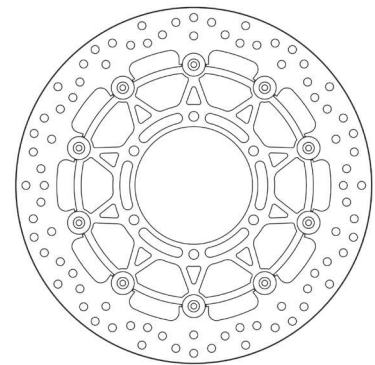

SUZUKI	Year	A/P
GSX-R 600	08->19	A
GSX-R 750	08->19	A
GSX-R 1000	09->16	A

**DF5305**

EF

ØE:310 ØC:110 ØI:94,2 ØF:6,5 N°:6 SP:5 OS:12,6

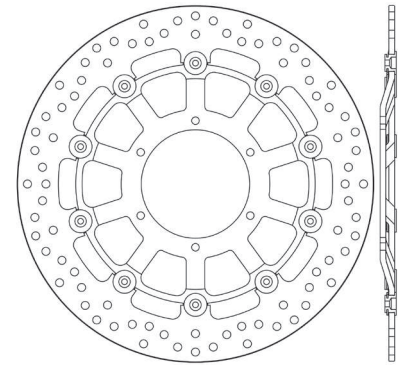

HONDA	Year	A/P
CBR 600 RR	03->15	A
CBR 600 RR ABS	09->17	A
CB 1000 R ABS	08->16	A
CBR 1000 RR FIREBLADE	04->05	A
CB 1300 F SUPER FOUR	03->04	A
CB 1300 R	02->04	A
CB 1300 S	11->15	A
CB 1300 SUPER BOLDOR	05->08	A
CB 1300 SUPERFOUR	05->13	A
CTX 1300	14->14	A

FIGURATO DISCHI FRENO CON APPLICAZIONI | BRAKE DISCS DRAWINGS AND APPLICATIONS | DESSINS DISQUES DE FREIN AVEC APPLICATIONS  
DISEÑOS DISCOS DE FRENO CON RELACION | ZEICHNUNGEN VON BREMSSCHEIBEN MIT VERWENDUNGSLISTE





# DF5306

**EF**

ØE:320 ØC:80 ØI:64,2 ØF:8,5 N°:6 SP:5 OS:10,3

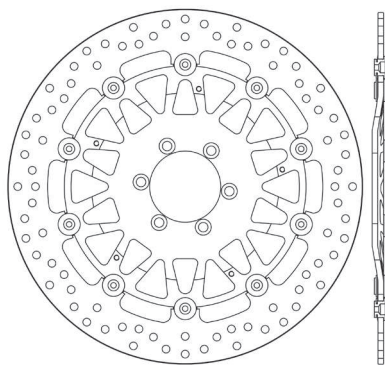

APRILIA	Year	A/P
AF1 125 EUROPA	90->92	A
AF1 125 FUTURA	90->91	A
MX 125	04->08	A
RS 125	95->99	A
TUONO 125	03->07	A
PEGASO 660 FACTORY	07->09	A
PEGASO 660 STRADA	05->09	A
DORSODURO 750 FACTORY	10->13	A
DORSODURO 750 SMV	08->18	A
SHIVER 750 SL	07->18	A
SHIVER GT 750 SL	09->12	A
NA 850 MANA	07->11	A
NA 850 MANA GT	09->16	A
DORSODURO 900	17->20	A
SHIVER 900	17->20	A
RSV 1000 MILLE	97->03	A
RSV 1000 MILLE NERA	04	A
RSV 1000 MILLE R	00->07	A
RSV 1000 MILLE R FACTORY	04->05	A
RSV 1000 SP	99->00	A
RSV 1000 TUONO	02->05	A
RSV 1000 TUONO FIGHTER	03->05	A
RSV 1000 TUONO R	03->12	A
RSV 1000 TUONO R FACTORY	06->12	A
RSV 1000 TUONO V4R	11->13	A
RSV4 1000 FACTORY	09->10	A
RSV4 1000 FACTORY ABS	13	A
RSV4 1000 FACTORY APRC	11->12	A
RSV4 1000 FACTORY APRC R - ABS	11->13	A
RSV4 1000 FACTORY APRC STD-SE	11->12	A
RSV4 1000 SBK RACING	09->10	A
RSV4-R 1000	10	A
RSV4-R 1000 APRC - ABS	11->14	A
RSV4-RF 1000	15->16	A
RSV4-RR 1000	15->16	A
SL 1000 FALCO	00->04	A
TUONO 1000 V4R APRC	14	A
TUONO 1000 V4R STD APRC	11->13	A
RSV 1100 TUONO V4	05	A
RSV 1100 TUONO V4 FACTORY	15->16	A
RSV 1100 TUONO V4 RR	15->16	A
CAPO NORD 1200	13->19	A
CAPO NORD 1200 RALLY	15->19	A
CAPO NORD 1200 TRAVEL PACK	16->19	A
DORSODURO 1200	11->15	A
BENELLI	Year	A/P
BN 302	14->	A
BN 600	14->	A
BN 600 GT	14->	A
BN 600 R	14->	A
TNT 899	07->	A
TNT 899 CENTURY RACER	11->	A
TRE-K 899	07->	A
TORNADO 3 900	00->02	A
TORNADO TRE 900	03->06	A
TORNADO TRE 900 RS	04->06	A
TNT 1100	04	A
TNT 1130	05->06	A

... segue BENELLI	Year	A/P
TNT 1130 CAFE RACER	05->06	A
TNT 1130 CENTURY RACER	11->	A
TNT 1130 OFFICINE	07->	A
TNT 1130 SPORT	05	A
TNT 1130 TITANIUM	05->	A
TNT 1130 TRE-K	06->	A
TNT 1130 TRE-K AMAZONAS	07	A
TORNADO 1130	06->	A
TORNADO 1130 TRE	06->08	A
TORNADO 1130 TRE R	13->	A
TRE-K 1130	06->16	A
TRE-K 1130 AMAZONAS	13->16	A
BIMOTA	Year	A/P
YB7 400	89->	A
V DUE 500	97->00	A
BB1 SUPERMONO 650	96->00	A
TESI 851 1D	90->91	A
DB2 SR 904	92->00	A
DB3 MANTRA 904	96->00	A
DB4 904	98->	A
DB5 1000 MILLE	05->11	A
SB8R 1000	97->00	A
YB10 1002 DIECI	92->95	A
SB6 1100	96->00	A
BMW	Year	A/P
G 650 X MOTO	06->07	A
CAGIVA	Year	A/P
MITO 125	91->92	A
MITO 125 525	06->10	A
MITO 125 EDDY	93	A
MITO 125 EURO 2	05->	A
MITO 125 EV	94->07	A
MITO 2 125 PRODUCTION RACER	94->	A
PLANET 125	97->07	A
RAPTOR 125	03->06	A
SUPERCITY 125	92->00	A
RIVER 500	99->01	A
RIVER 600	95->99	A
DUCATI	Year	A/P
SUPERSPORT 350	91->92	A
MONSTER 400	95->08	A
MONSTER 400 DARK IE	05	A
SUPERSPORT 400	93->97	A
MONSTER 600	93->01	A
MONSTER 600 CITY - CITY DARK - DARK	99	A
MONSTER 600 DARK	98	A
SUPERSPORT 600	91->97	A
MONSTER 620 (5 marce - single disk)	04	A
MONSTER 620 (6 marce)	04	A
MONSTER 620 DARK (single disk)	05	A
MONSTER 620 IE	02->04	A
MULTISTRADA 620 DARK (single disk)	06	A
SPORT 620	03->04	A
SUPERSPORT 620	03->04	A
MONSTER 696 (700cc)	08->14	A
748	02	A
748 BIPOSTO	01	A
748 BIPOSTO - SP	95->01	A
748 R	00	A
748 S	00->02	A
748 SP	95->97	A
748 SPS	98->99	A
MONSTER 750	96->01	A
MONSTER 750 CITY - CITY DARK	99	A
MONSTER 750 IE	02	A
SPORT 750	00->02	A
SUPERSPORT 750	91->02	A
SUPERSPORT 750 IE	00->02	A
MONSTER 800	03->04	A
SPORT 800	03->06	A
SUPERSPORT 800	03->06	A
851 all models	91->92	A
888 all models	93->95	A
888 DESMOQUATTRO	93->94	A
888 SUPERBIKE STRADA	94->95	A

... segue DUCATI	Year	A/P
MH 900	01->02	A
MONSTER 900	93->99	A
MONSTER 900 CITY - CITY DARK	99	A
MONSTER 900 CROMO	98->99	A
MONSTER 900 IE	00->02	A
MONSTER 900 SPECIAL	98	A
SPORT 900	02	A
SUPERSPORT 900	98->99	A
SUPERSPORT 900 F.E.	98	A
SUPERSPORT 900 IE	00->02	A
SUPERSPORT 900 SUPERLIGHT	91->97	A
907 IE	90->93	A
916 BIPOSTO SENNA	94->98	A
916 SP	94->96	A
916 SPS - SPS I/II/III (996cc)	97->00	A
MONSTER 916 S4	01->02	A
MONSTER 916 S4 FOGGY	02	A
ST4 916	99->03	A
ST2 944	97->03	A
996 S	01	A
MONSTER 996 S4R	03->06	A
ST4S 996	01->05	A
998 S	02->06	A
998 S (pinza radiale)	02->03	A
GT 1000	07->10	A
GT 1000 TOURING	09	A
MONSTER 1000	03->05	A
MONSTER 1000 S	05	A
PAUL SMART 1000 L.E.	06	A
SPORT 1000	06->08	A
ST3 1000	04->07	A
SUPERSPORT 1000	03->06	A
GILERA	Year	A/P
GFR 125	93->94	A
HONDA	Year	A/P
CB 1000 R	08->16	A
KTM	Year	A/P
LC4 640 DUKE II	03->06	A
LC4 690 DUKE	08->13	A
LC4 690 DUKE R	10->11	A
LC4 690 SM	07->09	A
LC4 690 SM PRESTIGE	07	A
LC4 690 SMC	08->11	A
LC4 690 SMC R	12->13	A
LC4 690 SMR	08	A
LC8 990 SUPER DUKE	05->12	A
LC8 990 SUPER DUKE R	07->13	A
RC8 1190	08->11	A
RC8 1190 R	09->15	A
RC8 1190 R TRACK	11->15	A
LAVERDA	Year	A/P
SPORT 650	95->01	A
DIAMANTE 668	96->98	A
GHOST 668	96->99	A
STRIKE 668	97->99	A
BLACK STRIKE 750	00->	A
FORMULA 750	97->01	A
SPORT 750	97->98	A
STRIKE 750	98->01	A
T-8 800	98	A
TTS 800	98	A
MONDIAL	Year	A/P
PIEGA 999 (1000cc)	03->	A
PIEGA EVO 999 (1000cc)	03->	A
PIEGA NUDA 999 (1000cc)	04->	A
MOTO GUZZI	Year	A/P
BREVA 750	03->09	A
NEVADA 750	91->97	A
NEVADA 750	02->03	A
NEVADA 750 AQUILA NERA	09->13	A
NEVADA 750 CLASSIC	04->07	A
NEVADA 750 CLUB	98->01	A
NEVADA 750 S	10	A
V7 750 CAFE CLASSIC	09	A
V7 750 CLASSIC	08->12	A

...DF5306		
... segue MOTO GUZZI	Year	A/P
V7 750 RACER	10->14	A
V7 750 SPECIAL	14	A
V7 750 SPECIAL - STONE	12->13	A
V7 750 STONE	14	A
V7 II 750 RACER ABS	15->16	A
V7 II 750 SPECIAL	15->16	A
V7 II 750 SPECIAL ABS	15->16	A
V7 II 750 STONE	14	A
V7 II 750 STONE - METAL	15->16	A
V7 II 750 STONE ABS	15->16	A
V7 II 750 STORNELLO	16->	A
V7 II 750 STORNELLO ABS	16->	A
BREVA 850	06->07	A
GRISO 850	06->07	A
NORGE 850	07->08	A
V9 850 BOBBER	16->	A
V9 850 ROAMER	16->	A
BELLAGIO 940 AQUILA NERA	07->10	A
DAYTONA 1000 RACING	96	A
DAYTONA 1000 RS	97->98	A
V 10 1000 CENTAURO	97->99	A
BREVA 1100	05->07	A
CALIFORNIA 1100 ALLUMINIUM - TITANIUM	04->05	A
CALIFORNIA 1100 EV	97->02	A
CALIFORNIA 1100 EVTOURING	03->05	A
CALIFORNIA 1100 JACKAL	99->06	A
CALIFORNIA 1100 SPECIAL	99->00	A
CALIFORNIA 1100 SPECIAL SPORT - ALLUMINIUM	02->03	A
CALIFORNIA 1100 SPORT	01->02	A
CALIFORNIA 1100 STONE - METAL	01->05	A
GRISO 1100	05->08	A
SPORT 1100 (iniezione)	96->99	A
SPORT 1100 CORSA	98->99	A
V 11 1100 LE MANS	01->05	A
V 11 1100 NAKED	03->05	A
V 11 1100 SCURA	02->05	A
V 11 1100 SPORT	99->05	A
V 11 1100 SPORT ROSSO MANDELL	01->06	A
V 11 1100 SPORT SCURA	02->	A
V11 1100 BALLABIO	03->05	A
V11 1100 CAFE SPORT	03->05	A
V11 1100 COPPA ITALIA	03->05	A
BREVA 1200 V	08->09	A
GRISO 1200 8V	07->	A
NORGE 1200	06->07	A
NORGE 1200 ABS	06->07	A
SPORT 1200	06->08	A
SPORT 1200 4V	09->11	A
SPORT 1200 8V	12->13	A
SPORT 1200 ABS	06->07	A
STELVIO 1200	08->11	A
MOTO MORINI	Year	A/P
9,5 1200	06->09	A
CORSARO 1200	05->09	A
SPORT 1200	08->10	A
MV AGUSTA	Year	A/P
F4 1000 312 R- 312 R 1+1- STOCK 312	08	A
F4 1000 S - R - RR - S 1+1 - R 1+1 - RR 1+1	06->07	A
F4 1000 S- S 1+1 - AGO - TAMBURINI - STOCK	02->05	A
F4 1000 SENNA	06	A
F4 1000 STOCK - VELTRO - SBK Replica	06	A
F4 1078 (1000cc)	07	A
MZ	Year	A/P
S 1000 (MUZ)	01->02	A
VOXAN	Year	A/P
CAFE RACER 1000	01->06	A
ROADSTER 1000	01->06	A
YAMAHA	Year	A/P
TDR 125	93->03	A
TDR 125 (Italia)	89->93	A
FZX 250 ZEAL	91->92	A
TDR 250	88->92	A
TZR 250	87->92	A
TZR 250 (REVERSE CYLINDER)	89->90	A
SZR 660	95->97	A

...DF5306		
... segue YAMAHA	Year	A/P
FZR 750 (OW01)	89->91	A
FZR 750 GENESIS	87->	A
YZ-F 750 RR-SP	93->98	A
FZR 1000 EX-UP	91->93	A
FZR 1000 GENESIS	86->89	A
FZR 1000 R	94->95	A
FZR 1000 R - EX-UP	89->90	A
XJR 1200	95->98	A

### DF5307

EF

ØE:320 ØC:90 ØI:72,1 ØF:8,5 N°:5 SP:5 OS:14,7

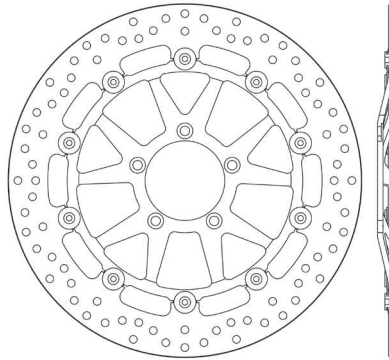

DUCATI		
	Year	A/P
749 (748cc)	03->06	A
749 DARK (748cc)	04->06	A
749 R (748cc)	04->06	A
749 S (748cc)	03->06	A
848 848	08->10	A
PANIGALE 899 ABS - USA	14->15	A
PANIGALE 956 959	17	A
PANIGALE 959 959	18	A
PANIGALE 959 959 CORSE / CORSE U	18->19	A
999 (998cc)	03->06	A
999 R (998cc)	03->06	A
999 RS (998cc) (con antisaltellamento)	04->05	A
999 S (998cc)	02->07	A
MONSTER 1000 S4R	07->08	A
MONSTER 1100 S	09->10	A

### DF5308

EF

ØE:320 ØC:150 ØI:132 ØF:8,5 N°:5 SP:5

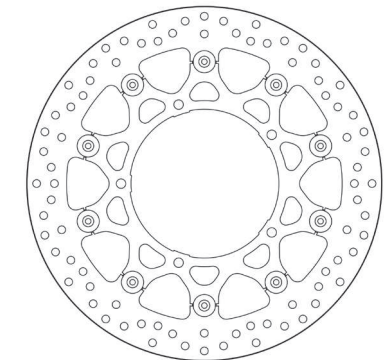

YAMAHA		
	Year	A/P
YZ-F 600 R6	17->20	A
FZ1 1000	06->12	A
FZ1 1000 FAZER	06->12	A
MT-10 1000	16->20	A
YZ-F 1000 R1	04->20	A
YZ-F 1000 R1M	15->20	A

### DF5309

EF

ØE:296 ØC:78 ØI:62,2 ØF:6,5 N°:6 SP:5 OS:17

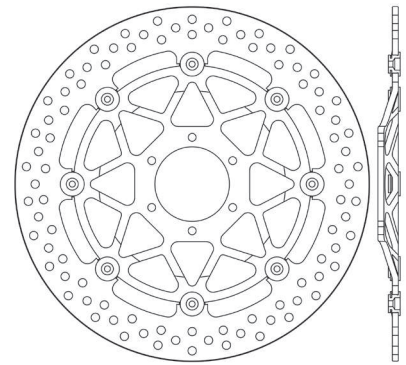

HONDA		
	Year	A/P
CBR 600 F	99->00	A
CROSSRUNNER 800 VFR	11->14	A
CROSSRUNNER 800 VFR X	15->18	A
VFR 800	06->13	A
VFR 800 F	14->16	A
VFR 800 FI	98->02	A
VFR 800 V-TECH	02->05	A
CBR 900 RR-FIREBLADE (893 cc)	92->94	A
XL 1000 VVARADERO	99->02	A
XLV 1000 VARADERO	03->11	A
XLV 1000 VARADERO ABS	04->11	A
GL 1500 F6C VALKYRIE	97->03	A
GL 1800 GOLDWING	01->17	A

### DF5310

EF

ØE:310 ØC:150 ØI:132 ØF:8,5 N°:5 SP:5

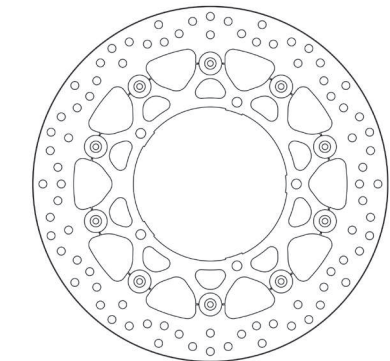

YAMAHA		
	Year	A/P
YZ-F 600 R6	05->16	A
FZ8 N 800	11->15	A
FZ8 NA 800	11->15	A
FZ8 S 800 FAZER	11->15	A
FZ8 SA 800 FAZER	11->15	A
YZ-F 1000 R1	07->14	A
XT 1200 Z SUPER TENERE	10->20	A
XT 1200 ZE SUPER TENERE	14->19	A

750

ØE

DIAM. ESTERNO  
outside diam / diam extern /  
diam exterior / Außendurchmesser

ØC

DIAM. CIRCOLARE PASSANTE / diam through  
the holes / diam entre trous / diám a través  
de los agujeros / Durchmesser durch die Löcher

ØI

DIAM. INTERNO  
inside diam / diam intérieure /  
diam interior / Innendurchmesser





**DF5311** EF

ØE:298 ØC:150 ØI:132 ØF:8,6 N°:5 SP:5

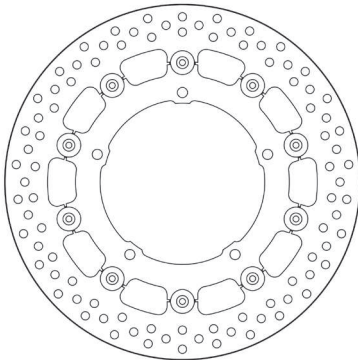

YAMAHA	Year	A/P
YZF R25 250	15->16	A
MT-03 320	16->20	A
YZF R3 320	15->20	A
FZ6 600 FAZER	04->07	A
FZ6 600 FAZER ABS	06->07	A
FZ6 N 600	04->07	A
FZ6 NS 600	05->06	A
FZ6 S2 600	07->09	A
FZ6 S2 600 FAZER	07->09	A
FZ6 S2 600 FAZER ABS	08	A
XJ6 600 DIVERSION	09->15	A
XJ6 F 600 DIVERSION	09->16	A
XJ6 N 600 DIVERSION	09->16	A
XJ6 S 600 DIVERSION	09->15	A
YZ-F 600 R6	03->04	A
MT-03 660	06->14	A
MT-09 900 (MTN 850)	17->20	A
MT-09 900 SP (MTN850)	18	A
MT-09 900 STREET RALLY (850cc)	14->16	A
MT-09 900 TRACER (850cc)	17->18	A
MT-09 900 TRACER (MTT850)	19->20	A
MT-09 900 TRACER GT (MTT850)	18	A
XSR 900 (850)	16->20	A
XV 1700 ROAD STAR WARRIOR	02	A

**DF5312** EF

ØE:298 ØC:150 ØI:132,2 ØF:8,6 N°:6 SP:5

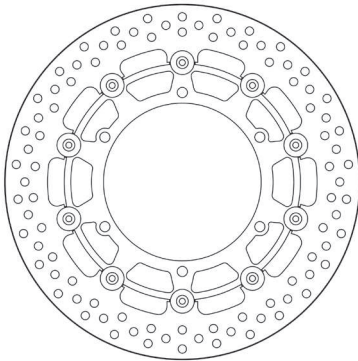

YAMAHA	Year	A/P
SR 400	14->16	A
XJ 600 N	98->03	A
XJ S 600 DIVERSION	98->03	A
YZ-F 600 R THUNDER CAT	96->04	A
YZ-F 600 R6	99->02	A
TDM 900	02->12	A
TDM 900 ABS	05->10	A
FZS 1000 FAZER	01->05	A
YZ-F 1000 R THUNDER ACE	96->01	A
YZ-F 1000 R1	98->03	A
BT 1100 BULLDOG	02->06	A
V-MAX 1200 (YMX 12N)	93->03	A
EJR 1300 A	13->20	A

**...DF5312**  
... segue YAMAHA

Year	A/P
XJR 1300	99->11 A
XJR 1300 SP	01 A

**DF5313** EF

ØE:320 ØC:91 ØI:69,2 ØF:10,5 N°:5 SP:5

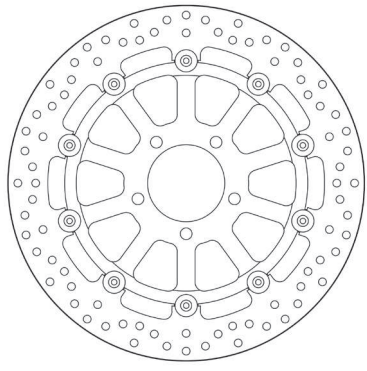

SUZUKI	Year	A/P
GSX-R 600	96->03	A
GSX-R 750	00->03	A
GSX-R 750 T SRAD	96->99	A
GSX-R 1000	01->02	A
TL 1000 R	98->03	A
TL 1000 S	97->02	A
GSX-R 1300 HAYABUSA	99->07	A
GSX 1400	02->07	A

**DF5314** EF

ØE:320 ØC:110 ØI:94,5 ØF:6,2 N°:6 SP:5 OS:15,2

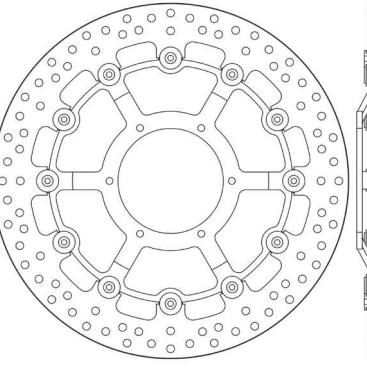

HONDA	Year	A/P
CBR 1000 RR FIREBLADE	08->16	A
CBR 1000 RR FIREBLADE ABS	09->16	A
CBR 1000 RR SP	14->16	A

**DF5315** EF

ØE:320 ØC:110 ØI:94,1 ØF:6,3 N°:6 SP:5 OS:12,8

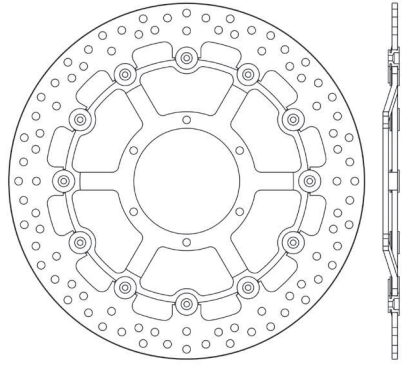

HONDA	Year	A/P
CBR 1000 RR FIREBLADE	06->07	A
VTR 1000 SP	00->07	A

**DF5317** A OE

ØE:240 ØC:133 ØI:115,1 ØF:6,5 N°:6 SP:4

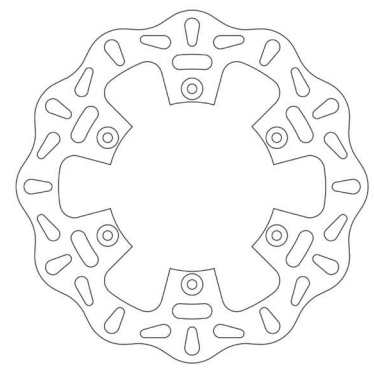
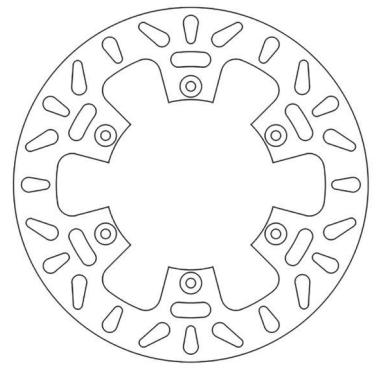

YAMAHA	Year	A/P
YZ-F 450	20	P

FIGURATO DISCHI FRENO  
BRAKE DISCS DRAWINGS

**DF5318**

A

ØE:270 ØC:89,5 ØI:70,5 ØF:6,5 N°:6 SP:3

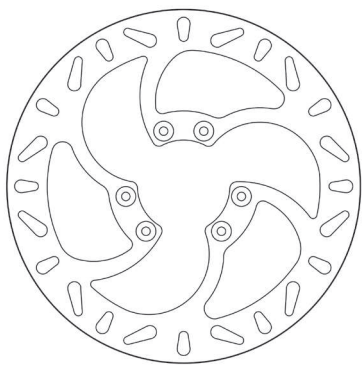

TM	Year	A/P
EN 125	04->20	A
MX 125	04->20	A
EN 144	14->20	A
MX 144	15->20	A
EN 250	04->20	A
EN 250 F	04->20	A
MX 250	05->20	A
MX 250 F	05->20	A
MX 300	05->20	A
MX 450 F	14->20	A
EN 530 F	05->20	A
MX 530 F 4T	05->20	A

**DF5319**

A

ØE:240 ØC:128 ØI:114 ØF:6,5 N°:4 SP:4

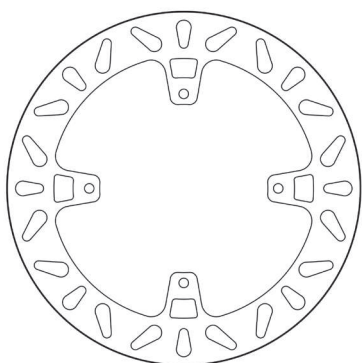

TM	Year	A/P
EN 125	15->20	P
MX 125	15->20	P
EN 144	15->20	P
MX 144	15->20	P
EN 250	15->20	P
EN 250 F	15->20	P
MX 250	15->20	P
MX 250 F	15->20	P
MX 300	15->20	P
MX 450 F	15->20	P
EN 530 F	15->20	P
MX 530 F 4T	15->20	P

FIGURATO DISCHI FRENO CON APPLICAZIONI | BRAKE DISCS DRAWINGS AND APPLICATIONS | DESSINS DISQUES DE FREIN AVEC APPLICATIONS |  
DISEÑOS DISCOS DE FRENO CON RELACION | ZEICHNUNGEN VON BREMSSCHEIBEN MIT VERWENDUNGSLISTE

752

ØE

**DIAM. ESTERNO**  
outside diam / diam extern /  
diam exterior / Außendurchmesser

ØC

**DIAM. CIRCOLARE PASSANTE** / diam through  
the holes / diam entre trous / diám a través  
de los agujeros / Durchmesser durch die Löcher

ØI

**DIAM. INTERNO**  
inside diam / diam intérieur /  
diam interior / Innendurchmesser



## DFST01



YAMAHA	Year	A/P
WR 125	01->02	A
YZ 125	01->04	A
WR F 250	01->04	A
YZ 250	01->04	A
YZ-F 250	01->04	A
WR F 400	98->02	A
YZ-F 400	98->99	A
WR F 426	00->02	A
YZ-F 426	00->02	A
WR F 450	03->04	A
YZ-F 450	03->04	A

## DFST02



HONDA	Year	A/P
CR 125 R	95->03	A
CR 250 R	95->03	A
CRE 250	02->03	A
XR 400 R	96->05	A
XR 440 R (DALLARA)	99->	A
CRF 450 R - E	02->03	A
CR 500 R	95->01	A
XR 600 L - R	93->00	A
XR 600 R	91->92	A
XR 650 R	00->07	A

## DFST03

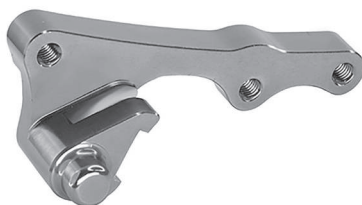

KAWASAKI	Year	A/P
KX 125	94->08	A
KX 250	94->08	A
KX F 250	04->14	A
KLX 450 R	08->20	A
KX F 450	06->14	A
KX 500	94->04	A
SUZUKI	Year	A/P
RM 125	96->12	A
RM 250	97->08	A
RMX 250	89->99	A
RMZ 250	04->18	A
DR Z 400 E	00->09	A
DR Z 400 S	00->08	A
RMX 450	10->17	A
RMZ 450	05->17	A

## DFST05



HONDA	Year	A/P
CR 125 R	04->07	A
CRE 125	02->07	A
CR 250 R	04->10	A
CRE 250	04->07	A
CRE 250 IE	07->08	A
CRF 250 R - E	04->14	A
CRF 250 X	04->17	A
CRE 290 IE	07->08	A
CRF 300 X	08->12	A
CRF 450 R - E	04->14	A
CRF 450 X	05->14	A

## DFST06



YAMAHA	Year	A/P
WR 125	01->02	A
YZ 125	01->07	A
WR F 250	01->07	A
YZ 250	01->07	A
YZ-F 250	01->06	A
WR F 400	98->02	A
YZ-F 400	98->99	A
WR F 426	00->02	A
YZ-F 426	00->02	A
WR F 450	03->08	A
YZ-F 450	03->07	A

## DFST07



KTM	Year	A/P
EXC 125	98->09	A
EXC 125 SIX DAYS	01->09	A
EXE 125	00->09	A
SX 125	96->09	A
SXS 125	01->10	A
SX 144	07->10	A
SX 150	08->09	A
EXC 200	04->09	A
SX 200	03->07	A
EXC 250	94->09	A
EXC 250 SIX DAYS (2T)	05->09	A
EXC RACING 250 (4T)	00->06	A
EXC-F 250	06->09	A
EXC-F 250 SIX DAYS	07->09	A
MX 250	00->13	A
SX 250	94->09	A
SX-F 250	05->09	A
SXS 250	01->03	A
SXS-F 250	06->08	A
XC 250 (2T)	94->09	A
EXC 300	94->09	A
EXC 300 EGS	93->99	A
EXC 300 SIX DAYS (2T)	05->09	A
EXC 360	96->97	A
SX 360	96->97	A
EXC 380	98->02	A
MXC 380	98->02	A

...DFST07		
... segue KTM	Year	A/P
SX 380	98->02	A
EXC 400	00->04	A
EXC RACING 400	00->07	A
EXC-G RACING 400	04->08	A
MXC 400	00->02	A
SX 400	00->02	A
SX RACING 400	02	A
SXC 400	99->00	A
EXC RACING 450	03->07	A
EXC-R 450	08	A
MXC 450	04->06	A
SX 450	03->06	A
SX-F 450	07->09	A
XC 450	06->07	A
XC-W 450	08	A
SX-F 505	07->09	A
XC-F 505	07->09	A
EXC RACING 520	00->02	A
MXC 520	00->02	A
SX 520	00->02	A
EXC RACING 525	03->07	A
MXC 525	03->05	A
SX 525	03->07	A
XC 525	06->07	A
EXC-R 530	08	A
XC-W 530	08	A
LC4 540 SXC	98->00	A
SXS 540 RACING	02	A

### DFST08



YAMAHA	Year	A/P
YZ 125	05->07	A
WR F 250	05->16	A
YZ 250	05->07	A
YZ-F 250	05->06	A
WR F 450	05->15	A
YZ-F 450	05->15	A

### DFST09



MALAGUTI	Year	A/P
MADISON 125	99->02	A

...DFST09		
... segue MALAGUTI	Year	A/P
PHANTOM MAX 125	03->	A
MADISON T 150	99->01	A
MADISON R 180	01->02	A
MADISON 200	99->01	A
MADISON S 200 RESTYLING	02->03	A
PHANTOM MAX 200	03	A
MADISON RS 250 RESTYLING	04	A
PHANTOM MAX 250	04	A

### DFST10



GILERA	Year	A/P
RUNNER 125	97->99	A
RUNNER 125 FX - FXR	97->02	A
RUNNER 125 SP	99->	A
RUNNER 125 VX / VXR 4T	01->04	A
RUNNER 180	97->98	A
RUNNER 180 FXR	98->	A
RUNNER 180 SP	99->	A
RUNNER 180 VXR	01->04	A
RUNNER 200 VXR 4T (pinza Heng Tong)	01->06	A
RUNNER 200 VXR 4T RACE	05->06	A
RUNNER 200 VXR 4T ST EURO 3	08->11	A

### DFST11



HONDA	Year	A/P
@ 125 NES (tambuto post/rear drum)	00->	A
SH 125 (tambuto post/rear drum)	00->08	A
@ 150 NES (tambuto post/rear drum)	00->	A
SH 150 (tambuto post/rear drum)	00->08	A

### DFST12



HONDA	Year	A/P
CR 85	03->07	A
CRF 150 R	07->20	A

### DFST13



KTM	Year	A/P
SX 85	03->10	A
XC 85	07->09	A
SX 105	04->09	A
XC 105	08->10	A

### DFST14

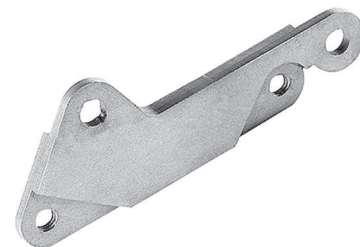

YAMAHA	Year	A/P
YZ 85	02->20	A



## DFST15



YAMAHA	Year	A/P
YZ 125	08->16	A
YZ 250	08->16	A
YZ-F 250	07->15	A
YZ-F 450	08->09	A

## DFST16



HUSQVARNA	Year	A/P
TC 125	14->20	A
TE 125	14->16	A
TE 125 4T	11->13	A
TX 125	17->20	A
FC 250	14->20	A
FE 250	13->20	A
TC 250	14->20	A
TE 250	14->17	A
TE 250 i	18->20	A
TC 300	14->17	A
TE 300	14->17	A
TE 300 i	18->20	A
TX 300	19	A
TX 300 i	20	A
FC 350	14->20	A
FE 350	14->20	A
FX 350	17->20	A
FC 450	14->20	A
FE 450	14->20	A
FX 450	19->20	A
TE 450	14	A
FE 501	14->20	A
KTM	Year	A/P
EXC 125	10->15	A
EXC 125 SIX DAYS	10->16	A
EXE 125	10->11	A
SX 125	10->20	A
SX 150	10->20	A
XC 150	11->18	A
EXC 200	10->16	A
XC-W 200	11->16	A
EXC 250	10->17	A
EXC 250 SIX DAYS (2T)	10->17	A

## ...DFST16

... segue KTM	Year	A/P
EXC 250 SIX DAYS TPI (2T)	18->20	A
EXC 250 TPI (2T)	18->20	A
EXC-F 250	10->20	A
EXC-F 250 SIX DAYS	10->20	A
SX 250	10->20	A
SX-F 250	10->20	A
XC 250 (2T)	10->17	A
XC 250 TPI (2T)	18->19	A
XC-F 250	11->20	A
XC-W 250 (2T)	11->17	A
XC-W 250 TPI (2T)	18->19	A
XCF-W 250	12->17	A
EXC 300	10->16	A
EXC 300 SIX DAYS (2T)	10->17	A
EXC 300 SIX DAYS TPI (2T)	18->20	A
EXC 300 TPI (2T)	18->20	A
XC 300 (2T)	11->19	A
XC 300 TPI (2T)	20	A
XC-W 300 (2T)	14->18	A
XC-W 300 SIX DAYS (2T)	18	A
XC-W 300 TPI (2T)	19->20	A
XC-W 300 TPI SIX DAYS (2T)	19->20	A
EXC-F 350	12->20	A
EXC-F 350 SIX DAYS	12->20	A
SX-F 350	11->20	A
XC-F 350	11->20	A
XCF-W 350	11->20	A
EXC-F 450	17->20	A
EXC-F 450 SIX DAYS	17->20	A
EXC-R 450	09->16	A
EXC-R RACING 450 (USA)	11	A
SX-F 450	10->20	A
XC-F 450	14->20	A
XC-W 450	09->16	A
XC-W 450 SIX DAYS (USA)	11	A
EXC 500 4T	12->16	A
EXC-F 500	17->20	A
EXC-F 500 SIX DAYS	17->20	A
XC-W 500	12->16	A
XCF-W 500	20	A
EXC-R 530	09->11	A
EXC-R RACING 530 (USA)	11	A
XC-W 530	09->11	A
XC-W 530 SIX DAYS	11	A
XC-W 530 SIX DAYS (USA)	11	A

## DFST18

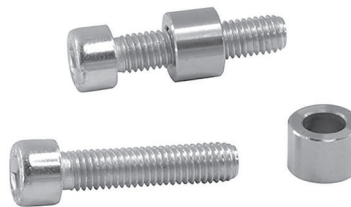

KTM	Year	A/P
SX 85	12->20	A
SXS 85	12->15	A

