



odigeTM
RACING PARTS *ITALY*

CATALOGO
GENERALE
GENERAL
CATALOGUE
2016

adigeTM
RACING PARTS ITALY

Indice

Index

Applicazioni

Applications

page 4

Frizioni

Clutches

Serie Dischi Rivestiti e Racing

Friction Plate Kit and Racing

page 132

Serie Completa Dischi Frizione e Racing

Clutch Plates Complete Set and Racing

page 167

Frizioni Antisaltellamento Aptc

Slipper Clutches Aptc

page 192

Carter Frizione

Clutch Housing

page 202

Freni

Brakes

Pastiglie freno - Brake Pads

Ganasce Freno - Brake Shoes

Dischi Freno - Brake Discs

page 206

page 282

page 290

Lamelle - Reeds

page 308

Valvole Lamellari - Reed Valve

page 316

Valvole power Reed - Power Reed Valve

page 322

Collettori di Aspirazione - Intake Manifolds

page 324

Fermacopertoni - Tire Locks

page 330

ADLER S.p.A. si riserva il diritto di variare codici ed applicazioni in qualsiasi momento senza preavviso.
ADLER S.p.A. reserves the right to change part numbers and applications in every moment without any notice.

MARCA - MODELLO MAKE - MODEL



Serie
Dischi Rivestiti
Friction Plate Kit



RACING
Serie
Dischi Rivestiti
Friction Plate Kit



Serie Completa
Dischi Frizione
Clutch Plates
Complete Set



RACING
Serie Completa
Dischi Frizione
Clutch Plates
Complete Set



Frizione
Antisaltemento
Slipper Clutches



Carter Frizione
Clutch Covers

ADLY	CC	MY	COD	PAG	COD	PAG	COD	PAG	COD	PAG	COD	PAG	COD	PAG
CAT	50	01												
COSY	50	01												
FOX	50	07												
FOX PLUS	50	01												
JET	50	96												
NOBLE/THUNDERBIKE	50	07												
PANTHER	50	07												
THUNDERBIKE	150	07												
ADLY ATV	CC	MY												
ATV 150	150	05												
INTERCEPTOR 150	150	05												
ATV 300	300	05												
CROSS X OVER 300	300	07												
CROSS X ROAD 300	300	07												
SPORT 300	300	07												
S 320	320	07												
U 320	320	07												
AEON	CC	MY												
AERO 50	50	06												
REGAL 50	50	06												
TORCH 50	50	06												
PULSAR 100	100	06												
REVO 2 100	100	04												
AERO 110	110	06												
PULSAR 110	110	06												
PULSAR 125	125	06												
PULSAR 150	150	06												
ALFER	CC	MY												
MC	80	88												
MC CROSS	80	89												
MC	125	88												
VRE 4-STROKE	125	00												
AR	250	92												
AR	250	93												
GR ENDURO	250	85												
MC	250	85												
NO LIMITS	250	95												
VR	250	94												
VR ENDURO	250	95												
VR MOTOCROSS	250	95												
VR SUPERMOTARD	250	99												
GR ENDURO	300	85	88											
GR ENDURO	300	89												
TX	300	90												
APRILIA	CC	MY												
AF 1	50	85	FB-116	141					FB-123/C	177				
AF 1 AE	50	86	FB-116	141					FB-123/C	177				
AF 1 FUTURA	50	91	FB-132	142	FB-132/M	142	FB-140	178	FB-140/C	178				
AMICO	50	90	91											
AMICO SPORT LX	50	92												
AREA 51	50	98	99											
AREA 51 SBK	50	00	02											
CLASSIC	50	96	FB-132	142	FB-132/M	142	FB-140	178	FB-140/C	178				
ET	50	85	FB-116	141					FB-123/C	177				
ET AE	50	87	FB-116	141					FB-123/C	177				
EUROPA	50	91	FB-132	142	FB-132/M	142	FB-140	178	FB-140/C	178				
GULLIVER	50	95	00											
GULLIVER L.C.	50	96	00											
HABANA	50	98	05											
MOJITO	50	99	05											

FRENI - BRAKES

VALVOLE - REEDS

COLLETTORI INTAKE MANIFOLDS

FERMACOPERTONI TIRE LOCKS

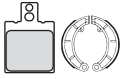

Pastiglie/Ganasce Anteriore
Front Brake Pads/Shoes

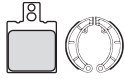

Pastiglie/Ganasce Posteriori
Rear Brake Pads/Shoes



Dischi Freno Anteriore
Front Brake Disk



Dischi Freno Posteriori
Rear Brake Disk



Lamelle
Reeds



Valvole Lamellari
Reed Valve



Valvola Power Reed
Power Reed Valve



Collettori Aspirazione
Intake Manifolds



Fermacopertoni Anteriore
Front Tire Locks



Fermacopertoni Posteriori
Rear Tire Locks

COD	PAG	COD	PAG	COD	PAG	COD	PAG	COD	PAG	COD	PAG	COD	PAG	COD	PAG	COD	PAG	COD	PAG
P.141	229																		
P.141	229																		
P.141	229	01205	288																
P.141	229																		
P.141	229	01205	288																
P.030	210	01205	288																
P.030	210	01205	288																
P.030	210	P.030	210																
P.260	277	P.260	277																
P.260	277	P.260	277																
P.260	277	P.260	277																
P.240	268																		
P.240	268																		
P.240	268																		
P.240	268																		
P.240	268																		
P.260	277																		
P.260	277																		
P.260	277																		
P.260	277																		
P.260	277	P.260	277																
P.260	277																		
P.260	277																		
P.260	277																		
P.012	208	P.012	208																
P.012	208	P.012	208																
P.085	219	P.012	208																
P.143	230	P.172	238																
		P.075	217																
P.143	230	P.075	217																
P.012	208																		
P.012	208																		
P.143	230	P.172	238																
P.143	230	P.075	217																
P.143	230	P.172	238																
P.143	230	P.172	238																
P.143	230	P.172	238																
P.012	208																		
		P.085	219																
P.065	213	P.012	208																
P.071	215							29	312										
P.098	222							29	312										
P.098	222							29	312										
01200	288	01200	288					77	314					FB-134	327				
P.139	228	01200	288	DF-12	297			77	314					FB-134	327				
P.139	228	P.139	228			DF-1	292	98	315	FB-146	319			FB-135	328				
P.139	228	P.139	228			DF-1	292	98	315	FB-146	319			FB-135	328				
P.158	233	01200	288					29	312										
P.012	208	P.012	208					27	312	MF-84	321								
P.098	222							29	312										
P.098	222							29	312										
P.139	228	01200	288	DF-1	292			98	315	FB-146	319			FB-135	328				
P.139	228	01200	288	DF-1	292			98	315	FB-146	319			FB-135	328				
P.139	228			DF-1	292			90	314										
P.139	228			DF-1	292			90	314										

MARCA - MODELLO MAKE - MODEL



Serie
Dischi Rivestiti
Friction Plate Kit



RACING
Serie
Dischi Rivestiti
Friction Plate Kit



Serie Completa
Dischi Frizione
Clutch Plates
Complete Set



RACING
Serie Completa
Dischi Frizione
Clutch Plates
Complete Set



Frizione
Antisaltellamento
Slipper Clutches



Carter Frizione
Clutch Covers

APRILIA	CC	MY	COD	PAG	COD	PAG	COD	PAG	COD	PAG	COD	PAG	COD	PAG
MX SUPERMOTARD	50	02	FB-132	142	FB-132/M	142	FB-140	178	FB-140/C	178				
PEGASO	50	94	FB-132	142	FB-132/M	142	FB-140	178	FB-140/C	178				
RALLY	50	94	00											
RALLY L.C.	50	97												
RED ROSE	50	88	91	FB-116	141				FB-123/C	177				
RED ROSE	50	92		FB-132	142	FB-132/M	142	FB-140	178	FB-140/C	178			
RS	50	96	99	FB-132	142	FB-132/M	142	FB-140	178	FB-140/C	178			
RS	50	00	06	FB-132	142	FB-132/M	142	FB-140	178	FB-140/C	178			
RS	50	07		DB-12	136			DB-12/M	170					
RS EXTREMA	50	94		FB-132	142	FB-132/M	142	FB-140	178	FB-140/C	178			
RS REPLICA	50	99		FB-132	142	FB-132/M	142	FB-140	178	FB-140/C	178			
RS4 504T	50	11												
RX	50	90	91	FB-116	141				FB-123/C	177				
RX	50	92	97	FB-132	142	FB-132/M	142	FB-140	178	FB-140/C	178			
RX	50	98		FB-132	142	FB-132/M	142	FB-140	178	FB-140/C	178			
RX C-CD	50	93		FB-132	142	FB-132/M	142	FB-140	178	FB-140/C	178			
RX RACING	50	04	06	FB-132	142	FB-132/M	142	FB-140	178	FB-140/C	178			
RX RACING	50	07		DB-12	136			DB-12/M	170	FB-140/C	178			
SCARABEO	50	94	97											
SCARABEO	50	94	95											
SCARABEO	50	96	97											
SCARABEO	50	98	02											
SCARABEO	50	03												
SCARABEO D-TECH	50	02	06											
SCARABEO DE LUXE	50	98	01											
SCARABEO STREET	50	07												
SONIC-SONIC G.P.	50	98												
SR	50	93	00											
SR D-TECH	50	01												
SR EUROPA	50	94												
SR R	50	05												
SR R FACTORY	50	05	06											
SR RACING KAT.	50	00												
SR REPLICA	50	92												
SR REPLICA	50	93												
SR STEALTH L.C.	50	97												
SR STREET	50	07												
SR URBAN	50	94												
SR WWW	50	97												
SX	50	06		FB-132	142	FB-132/M	142	FB-140	178	FB-140/C	178			
TUAREG	50	85		FB-116	141					FB-123/C	177			
TUAREG	50	86		FB-116	141					FB-123/C	177			
TUAREG	50	87	90	FB-116	141					FB-123/C	177			
TUAREG	50	91		FB-132	142	FB-132/M	142	FB-140	178	FB-140/C	178			
TUAREG RALLY	50	90		FB-132	142	FB-132/M	142	FB-140	178	FB-140/C	178			
TUAREG WIND	50	90		FB-132	142	FB-132/M	142	FB-140	178	FB-140/C	178			
TUONO	50	04		FB-132	142	FB-132/M	142	FB-140	178	FB-140/C	178			
CLASSIC	80	93		FB-132	142	FB-132/M	142	FB-140	178	FB-140/C	178			
SCARABEO	100	00	02											
SCARABEO	100	03	07											
AF 1	125	85		BR-46	135			BR-50	167					
AF 1 FUTURA	125	90												
AF 1 FUTURA	125	90	92	BR-46	135			BR-50	167					
AF 1 REPLICA	125	89												
AF 1 SINTESI	125	88		BR-46	135			BR-50	167					
AF 1 SINTESI	125	89												
AF 1 SINTESI REPLICA	125	89	90	BR-46	135			BR-50	167					
ATLANTIC	125	03	06											
ATLANTIC	125	07												
CLASSIC	125	95	99	BR-46	135			BR-50	167					

FRENI - BRAKES

VALVOLE - REEDS

COLLETTORI INTAKE MANIFOLDS

FERMACOPERTONI TIRE LOCKS

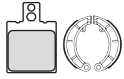

Pastiglie/Ganasce Anteriori
Front Brake Pads/Shoes

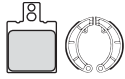

Pastiglie/Ganasce Posteriori
Rear Brake Pads/Shoes



Dischi Freno Anteriori
Front Brake Disk



Dischi Freno Posteriori
Rear Brake Disk



Lamelle
Reeds



Valvole Lamellari
Reed Valve



Valvola Power Reed
Power Reed Valve



Collettori Aspirazione
Intake Manifolds



Fermacopertoni Anteriori
Front Tire Locks



Fermacopertoni Posteriori
Rear Tire Locks

COD	PAG	COD	PAG	COD	PAG	COD	PAG	COD	PAG	COD	PAG	COD	PAG	COD	PAG	COD	PAG	COD	PAG
P.158	233							29	312										
P.098	222	P.071	215					29	312										
P.139	228	01200	288	DF-1	292			98	315	FB-146	319			FB-135	328				
P.139	228	P.139	228	DF-1	292	DF-1	292	98	315	FB-146	319			FB-135	328				
P.098	222							29	312										
								29	312										
								29	312										
P.158	233							29	312										
P.186	244	P.065	213																
P.173	240							29	312										
P.158	233							29	312										
P.246	271																		
P.098	222							29	312							MA-139	332		
P.133	227							29	312							MA-139	332		
P.158	233							29	312							MA-139	332		
P.158	233							29	312							MA-139	332		
P.158	233							29	312							MA-139	332		
P.074	216																		
								98	315	FB-146	319			FB-135	328				
		01200	288																
P.139	228	01200	288																
P.139	228	01200	288	DF-2	292			98	315	FB-146	319			FB-135	328				
P.185	243	01200	288	DF-2	292														
P.139	228	P.139	228			DF-1	292												
P.139	228	P.139	228			DF-1	292	98	315	FB-146	319			FB-135	328				
P.139	228	0278	286																
P.139	228	01200	288	DF-12	297			98	315	FB-146	319			FB-135	328				
P.173	240	01200	288	DF-1	292			98	315	FB-146	319			FB-135	328				
P.139	228	P.139	228	DF-1	292	DF-1	292												
P.173	240	01200	288	DF-1	292	DF-1	292	98	315	FB-146	319			FB-135	328				
P.139	228	P.139	228	DF-1	292	DF-1	292												
P.012	208	P.184	243	DF-1	292	DF-22	300												
P.173	240	P.184	243	DF-1	292	DF-1	292	98	315	FB-146	319			FB-135	328				
		01200	288	DF-1	292			98	315	FB-146	319			FB-135	328				
P.173	240	01200	288	DF-1	292			98	315	FB-146	319			FB-135	328				
P.139	228	P.139	228	DF-1	292	DF-1	292	98	315	FB-146	319			FB-135	328				
P.139	228	P.184	243	DF-1	292	DF-1	292												
P.173	240	01200	288	DF-1	292			98	315	FB-146	319			FB-135	328				
P.139	228	P.139	228	DF-1	292			98	315	FB-146	319			FB-135	328				
P.074	216	P.065	213																
P.012	208							27	312	MF-84	321								
P.098	222							27	312	MF-84	321								
P.098	222	P.012	208					29	312							MA-139	332	MA-152	333
P.098	222							29	312							MA-139	332	MA-152	333
P.071	215							29	312							MA-139	332	MA-152	333
P.071	215							29	312							MA-139	332	MA-152	333
P.158	233																		
P.098	222							29	312							MA-139	332		
P.185	243			DF-2	292			98	315	FB-146	319			FB-135	328				
P.139	228	0278	286	DF-2	292			98	315	FB-146	319			FB-135	328				
								61	313	BR-51	318	PWR-2	323	BR-60	326				
		P.012	208					61	313	BR-51	318	PWR-2	323	BR-60	326				
		P.012	208					61	313	BR-51	318	PWR-2	323	BR-60	326				
P.085	219	P.012	208					61	313	BR-51	318	PWR-2	323	BR-60	326				
P.208	255	P.184	243			DF-22	300												
P.208	255					DF-22	300												

MARCA - MODELLO MAKE - MODEL



Serie
Dischi Rivestiti
Friction Plate Kit



RACING
Serie
Dischi Rivestiti
Friction Plate Kit



Serie Completa
Dischi Frizione
Clutch Plates
Complete Set



RACING
Serie Completa
Dischi Frizione
Clutch Plates
Complete Set



Frizione
Antisaltemento
Slipper Clutches



Carter Frizione
Clutch Covers

APRILIA	CC	MY	COD	PAG	COD	PAG	COD	PAG	COD	PAG	COD	PAG	COD	PAG
CLASSIC	125	96	01											
ETX	125	85												
ETX	125	86		BR-46	135			BR-50	167					
ETX PV	125	85												
EUROPA	125	90	91	BR-46	135			BR-50	167					
EUROPA	125	91												
HABANA	125	00												
LEONARDO	125	96	98											
LEONARDO	125	99	06											
MX	125	04												
MX	125	04	06	BR-46	135			BR-74	169					
PEGASO	125	89												
PEGASO	125	89	90	BR-46	135			BR-50	167					
PEGASO	125	91												
PEGASO	125	91	94	BR-46	135			BR-50	167					
PEGASO KAT	125	93		BR-46	135			BR-50	167					
RC	125	89		BR-46	135			BR-50	167					
RED ROSE	125	87	94	BR-46	135			BR-50	167					
RED ROSE	125	89												
RED ROSE AE	125	91		BR-46	135			BR-50	167					
RS	125	96	10	BR-46	135			BR-74	169					
RS	125	92	94	BR-46	135			BR-50	167					
RS	125	93	97											
RS	125	95		BR-46	135			BR-74	169					
RS	125	98	05											
RS 125	125	06												
RS4 1254T	125	11												
RS4 1254T	125	12												
RX	125	85	88	BR-46	135			BR-50	167					
RX	125	86	89											
RX	125	90												
RX	125	91												
RX	125	94		BR-46	135			BR-50	167					
RX	125	95	98	BR-46	135			BR-74	169					
RX	125	00	01											
RX	125	85												
RX	125	89	93	BR-46	135			BR-50	167					
RX	125	92	93											
RX	125	94	99											
RX - SX	125	08	10	BR-46	135			BR-74	169					
SCARABEO	125	07												
SCARABEO	125	98	03											
SCARABEO GT	125	04	06											
SPORT PRO	125	93		BR-46	135			BR-50	167					
SPORTCITY	125	05												
SR	125	99												
TUAREG RALLY	125	85	88	BR-46	135			BR-50	167					
TUAREG RALLY	125	89	90	BR-46	135			BR-50	167					
TUAREG RALLY	125	91												
TUAREG WIND	125	89		BR-46	135			BR-50	167					
TUONO	125	03	04	BR-46	135			BR-74	169					
TUONO	125	04												
TX M	125	85		BR-46	135			BR-50	167					
LEONARDO 4T	150	98												
LEONARDO 4T	150	99	04											
MOJITO	150	99	05											
SCARABEO	150	98	03											
SCARABEO GT	150	04	06											
SR	150	00												
ATLANTIC	200	03	04											

FRENI - BRAKES

VALVOLE - REEDS

COLLETTORI INTAKE MANIFOLDS

FERMACOPERTONI TIRE LOCKS

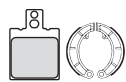

Pastiglie/Ganasce Anteriori
Front Brake Pads/Shoes

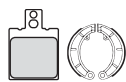

Pastiglie/Ganasce Posteriori
Rear Brake Pads/Shoes



Dischi Freno Anteriori
Front Brake Disk



Dischi Freno Posteriori
Rear Brake Disk



Lamelle
Reeds



Valvole Lamellari
Reed Valve



Valvola Power Reed
Power Reed Valve



Collettori Aspirazione
Intake Manifolds



Fermacopertoni Anteriori
Front Tire Locks



Fermacopertoni Posteriori
Rear Tire Locks

COD	PAG	COD	PAG	COD	PAG	COD	PAG	COD	PAG	COD	PAG	COD	PAG	COD	PAG	COD	PAG	COD	PAG
P.074	216							61	313	BR-51	318	PWR-2	323	BR-60	326				
P.012	208							61	313	BR-51	318	PWR-2	323	BR-54	326				
P.074	216							61	313	BR-51	318	PWR-2	323	BR-54	326				
P.074	216							61	313	BR-51	318	PWR-2	323	BR-54	326				
P.085	219	P.012	208					61	313	BR-51	318	PWR-2	323	BR-61	327				
P.185	243																		
P.139	228	P.139	228	DF-2	292	DF-1	292												
P.185	243	P.185	243	DF-2	292														
P.143	230							61	313	BR-51	318	PWR-2	323	BR-60	326				
		P.075	217					61	313	BR-51	318	PWR-2	323	BR-54	326	MA-139	332	MA-152	333
P.133	227							61	313	BR-51	318	PWR-2	323	BR-54	326	MA-139	332	MA-152	333
P.085	219	P.012	208					61	313	BR-51	318	PWR-2	323	BR-54	326	MA-139	332	MA-152	333
		P.079	218					61	313	BR-51	318	PWR-2	323						
P.074	216							61	313	BR-51	318	PWR-2	323	BR-53	326				
P.133	227	P.012	208					61	313	BR-51	318	PWR-2	323	BR-53	326				
P.085	219	P.012	208					61	313	BR-51	318	PWR-2	323	BR-60	326				
P.085	219	P.012	208					61	313	BR-51	318	PWR-2	323	BR-60	326				
P.262	279	P.184	243																
P.246	271																		
P.246	271	P.260	277																
P.074	216							61	313	BR-51	318	PWR-2	323	BR-54	326	MA-139	332	MA-152	333
		P.075	217					61	313	BR-51	318	PWR-2	323	BR-54	326	MA-139	332	MA-152	333
								61	313	BR-51	318	PWR-2	323	BR-54	326	MA-139	332	MA-152	333
P.143	230																		
P.012	208							61	313	BR-51	318	PWR-2	323	BR-54	326	MA-139	332	MA-152	333
P.133	227	P.075	217					61	313	BR-51	318	PWR-2	323	BR-54	326	MA-139	332	MA-152	333
P.158	233							61	313	BR-51	318	PWR-2	323	BR-54	326	MA-139	332	MA-152	333
P.208	255	P.184	243																
P.074	216	P.184	243	DF-18	299	DF-2	292												
P.208	255	P.184	243			DF-2	292												
P.085	219	P.012	208					61	313	BR-51	318	PWR-2	323	BR-61	327				
P.074	216	P.184	243	DF-18	299	DF-2	292												
P.185	243													VE-383	329				
P.074	216							61	313	BR-51	318	PWR-2	323	BR-54	326				
								61	313	BR-51	318	PWR-2	323	BR-54	326				
P.133	227							61	313	BR-51	318	PWR-2	323	BR-54	326				
		P.012	208					61	313	BR-51	318	PWR-2	323	BR-54	326				
P.085	219	P.012	208					61	313	BR-51	318	PWR-2	323	BR-60	326				
P.065	213							61	313	BR-51	318	PWR-2	323	BR-54	326	MA-139	332	MA-152	333
P.139	228	P.139	228	DF-2	292	DF-1	292												
P.185	243	P.184	243	DF-2	292	DF-1	292												
P.185	243	0278	286																
P.074	216	P.184	243	DF-18	299														
P.208	255	P.184	243	DF-18	299	DF-2	292												
P.139	228	0278	286	DF-1	292									VE-383	329				
P.208	255	P.184	243			DF-22	300												

MARCA - MODELLO MAKE - MODEL



Serie
Dischi Rivestiti
Friction Plate Kit



RACING
Serie
Dischi Rivestiti
Friction Plate Kit



Serie Completa
Dischi Frizione
Clutch Plates
Complete Set



RACING
Serie Completa
Dischi Frizione
Clutch Plates
Complete Set



Frizione
Antisaltemento
Slipper Clutches



Carter Frizione
Clutch Covers

APRILIA	CC	MY	COD	PAG	COD	PAG	COD	PAG	COD	PAG	COD	PAG	COD	PAG
ATLANTIC	200	05												
SCARABEO	200	07												
SCARABEO	200	01	02											
SCARABEO GT	200	03	06											
SPORTCITY	200	05	06											
TX	240	86		BR-46	135				BR-50	167				
AF1 250 REPLICA	250	90												
ATLANTIC	250	03	04											
ATLANTIC	250	05	06											
ATLANTIC I.E.	250	07												
CLIMBER	250	89												
CLIMBER	250	90		BR-46	135				BR-50	167				
CLIMBER R	250	92		BR-46	135				BR-50	167				
LEONARDO	250	99	00											
LEONARDO	250	01	04											
MX	250	83												
REPLICA	250	92												
RS	250	95	97	SU-29	158									
RS	250	98		SU-29	158									
RX	250	83												
SCARABEO	250	04	05											
SCARABEO	250	06												
SCARABEO I.E.	250	07												
SPORTCITY I.E.	250	07												
TUAREG RALLY	250	85		BR-20	134									
CLIMBER R	280	93		BR-46	135				BR-50	167				
LEONARDO	300	05												
SCARABEO S	300	09												
TX M	300	86		BR-46	135				BR-50	167				
TX M	311	85		BR-46	135				BR-50	167				
TXR M	312	88		BR-46	135				BR-50	167				
ETX	350	85												
ETX AE	350	87												
TUAREG	350	85												
TUAREG WIND	350	87												
TUAREG WIND	350	89												
ATLANTIC SPRINT	400	07												
SCARABEO I.E.	400	07												
RXV ENDURO	450	06									AP-7	194	AP-8	202
SXV SUPERMOTARD	450	06									AP-7	194	AP-8	202
ATLANTIC	500	02	04											
ATLANTIC SPRINT	500	05	07											
SCARABEO ABS	500	03	06											
SCARABEO CLASS	500	10												
SCARABEO I.E.	500	07												
RXV ENDURO	550	06									AP-7	194	AP-8	202
SXV SUPERMOTARD	550	06									AP-7	194	AP-8	202
ETX AE	600	85												
PEGASO 4 VALVOLE	600	91		BR-57	135				BR-58	168				
PEGASO AE	600	91		BR-57	135				BR-58	168				
TUAREG WIND	600	89		BR-36	134									
TUAREG WIND AE	600	91		BR-57	135				BR-58	168				
TUAREG WIND PARIGI DAKAR	600	89		BR-36	134									
MOTO 6.5	650	95		BR-66	135				BR-63	168				
PEGASO	650	91	93	BR-57	135				BR-58	168				
PEGASO	650	94	95	BR-66	135				BR-63	168				
PEGASO	650	96		BR-66	135				BR-63	168				
PEGASO	650	97	00	BR-66	135				BR-63	168				
PEGASO	650	07		BR-66	135				BR-63	168				
PEGASO	650	06		BR-66	135				BR-63	168				

FRENI - BRAKES

VALVOLE - REEDS

COLLETTORI INTAKE MANIFOLDS

FERMACOPERTONI TIRE LOCKS

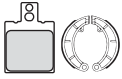

Pastiglie/Ganasce Anteriore
Front Brake Pads/Shoes

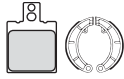

Pastiglie/Ganasce Posteriori
Rear Brake Pads/Shoes



Dischi Freno Anteriore
Front Brake Disk



Dischi Freno Posteriori
Rear Brake Disk



Lamelle
Reeds



Valvole Lamellari
Reed Valve



Valvola Power Reed
Power Reed Valve



Collettori Aspirazione
Intake Manifolds



Fermacopertoni Anteriore
Front Tire Locks



Fermacopertoni Posteriori
Rear Tire Locks

COD	PAG	COD	PAG	COD	PAG	COD	PAG	COD	PAG	COD	PAG	COD	PAG	COD	PAG	COD	PAG	COD	PAG
P.208	255	P.184	243			DF-22	300												
P.208	255	P.184	243	DF-18	299	DF-2	292												
P.074	216	P.184	243	DF-18	299	DF-2	292												
P.074	216	P.184	243	DF-18	299	DF-2	292												
P.074	216	P.184	243	DF-18	299	DF-2	292												
P.065	213																		
		P.245	270																
P.208	255	P.184	243																
P.208	255	P.184	243			DF-22	300												
P.208	255																		
P.065	213	P.065	213																
P.065	213																		
P.065	213																		
P.074	216	P.184	243	DF-2	292														
P.074	216	P.184	243	DF-2	292														
P.012	208																		
P.067	214	P.065	213																
P.067	214	P.139	228																
P.168	236	P.139	228																
P.012	208																		
		P.184	243	DF-18	299														
P.208	255	P.184	243	DF-18	299														
P.208	255	P.184	243	DF-18	299														
		P.184	243	DF-18	299	DF-2	292												
P.074	216	P.012	208																
P.065	213	P.065	213																
		P.184	243																
P.208	255	P.184	243																
P.065	213																		
P.065	213	P.065	213																
P.065	213	P.065	213																
P.074	216	P.012	208																
		P.012	208																
		P.012	208																
P.074	216	P.012	208																
		P.075	217																
P.208	255	P.184	243																
P.074	216	P.184	243	DF-18	299														
P.190	246																		
		P.205	253																
P.074	216	P.184	243	DF-18	299														
		P.184	243	DF-18	299	DF-2	292												
P.074	216	P.184	243	DF-18	299	DF-2	292												
P.074	216	P.184	243																
P.074	216	P.184	243	DF-18	299														
P.190	246	P.205	253																
		P.205	253																
P.074	216	P.012	208																
		P.075	217																
P.133	227																		
		P.075	217																
		P.075	217																
P.192	247																		
		P.173	240																
P.143	230																		
P.192	247	P.075	217																
P.168	236	P.172	238																
P.192	247	P.172	238																

MARCA - MODELLO MAKE - MODEL



Serie
Dischi Rivestiti
Friction Plate Kit



RACING
Serie
Dischi Rivestiti
Friction Plate Kit



Serie Completa
Dischi Frizione
Clutch Plates
Complete Set



RACING
Serie Completa
Dischi Frizione
Clutch Plates
Complete Set



Frizione
Antisaltemamento
Slipper Clutches



Carter Frizione
Clutch Covers

APRILIA	CC	MY	COD	PAG	COD	PAG	COD	PAG	COD	PAG	COD	PAG	COD	PAG
PEGASO I.E.	650	01	04	BR-66	135			BR-63	168					
PEGASO STRADA	650	05	06	BR-66	135			BR-63	168					
DORSODURO	750	08		AP-12	134			AP-11	167					
DORSODURO	750	08												
DORSODURO	750	09												
SHIVER	750	07		AP-12	134			AP-11	167					
SL 750 SHIVER	750	07												
SL 750 SHIVER GT	750	09												
SMV 750 DORSODURO	750	09												
MANA	850	07												
MANA GT	850	09												
NA 850 MANA	850	07												
NA 850 MANA	850	08												
NA 850 MANA GT	850	09												
BLUE MARLIN	1000	02		BR-64	135			BR-65	168					
CAPONORD RAID	1000	03												
ETV-CAPONORD/RAID	1000	01	02	BR-64	135			BR-65	168					
PEGASO	1000	01		BR-64	135			BR-65	168					
RST FUTURA	1000	01	04	BR-64	135			BR-65	168					
RSV 1000 TUONO V4R	1000	14												
RSV FACTORY	1000	04		BR-64	135			BR-65	168					
RSV MILLE	1000	98	00	BR-64	135			BR-65	168					
RSV MILLE	1000	01	05	BR-64	135			BR-65	168					
RSV MILLE NERA	1000	04		BR-64	135			BR-65	168					
RSV MILLE R	1000	00		BR-64	135			BR-65	168					
RSV MILLE R	1000	01	07	BR-64	135			BR-65	168					
RSV MILLE SL FALCO	1000	00		BR-64	135			BR-65	168					
RSV MILLE SP	1000	00		BR-64	135			BR-65	168					
RSV TUONO	1000	02		BR-64	135			BR-65	168					
RSV TUONO RACING	1000	04		BR-64	135			BR-65	168					
RSV4 FACTORY	1000	09												
RSV4 R	1000	10												
RSVR	1000	09												
RSV 1000 TUONO V4	1100	15												
CAPONORD	1200	13												
CAPONORD 1200	1200	13												
CAPONORD RALLY 1200	1200	15												
DORSODURO	1200	10		AP-13	134			AP-14	167					
DORSODURO	1200	11												
BENELLI	CC	MY												
491 GT	50	98												
491 NAKED	50	98												
491 SPORT	50	98												
491 SUPERBIKE-491 R	50	98												
K 2	50	98												
K 2 LIQUIDO	50	98												
K 2 NAMUR	50	98												
PEPE	50	99												
K 2	100	99												
ADIVA	125	00												
ADIVA	125	01	04											
VELVET	125	99	07											
ADIVA	150	00												
VELVET	150	99	07											
CAFFE NERO 250pinza dx	250	08												
VELVET	250	98	00											
VELVET	250	01	07											
350 SPORT	350	78												
350 SPORT II	350	78												
350 T	350	78												

FRENI - BRAKES

VALVOLE - REEDS

COLLETTORI INTAKE MANIFOLDS

FERMACOPERTONI TIRE LOCKS

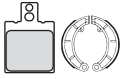

Pastiglie/Ganasce Anteriori
Front Brake Pads/Shoes

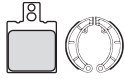

Pastiglie/Ganasce Posteriori
Rear Brake Pads/Shoes



Dischi Freno Anteriore
Front Brake Disk



Dischi Freno Posteriori
Rear Brake Disk



Lamelle
Reeds



Valvole Lamellari
Reed Valve



Valvola Power Reed
Power Reed Valve



Collettori Aspirazione
Intake Manifolds



Fermacopertoni Anteriore
Front Tire Locks



Fermacopertoni Posteriori
Rear Tire Locks

COD	PAG	COD	PAG	COD	PAG	COD	PAG	COD	PAG	COD	PAG	COD	PAG	COD	PAG	COD	PAG	COD	PAG
P.192	247	P.172	238																
P.168	236	P.172	238																
P.168	236	P.172	238																
		P.172	238																
		P.172	238																
P.262	279																		
P.262	279																		
P.262	279																		
		P.172	238																
		P.074	216																
P.262	279																		
P.262	279																		
P.262	279																		
P.168	236	P.186	244																
P.192	247	P.231	263																
P.192	247	P.186	244																
P.192	247	P.172	238																
P.168	236	P.143	230																
P.233	264																		
P.211	256	P.186	244																
P.168	236	P.186	244																
P.211	256	P.186	244																
P.211	256	P.186	244																
P.168	236	P.186	244																
P.211	256	P.186	244																
P.168	236	P.186	244																
P.168	236	P.186	244																
P.168	236	P.186	244																
P.211	256	P.186	244																
P.229	262	P.186	244																
P.229	262	P.186	244																
P.229	262	P.186	244																
P.233	264																		
P.233	264																		
P.233	264																		
P.233	264																		
P.168	236	P.172	238																
P.139	228	01200	288	DF-8	295			98	315	FB-146	319			FB-135	328				
P.139	228			DF-8	295			98	315	FB-146	319			FB-135	328				
P.139	228	01200	288	DF-8	295			98	315	FB-146	319			FB-135	328				
P.139	228	P.139	228	DF-8	295	DF-8	295	98	315	FB-146	319			FB-135	328				
P.139	228	P.139	228	DF-8	295			98	315	FB-146	319			FB-135	328				
P.139	228	P.139	228	DF-8	295	DF-8	295	98	315	FB-146	319			FB-135	328				
P.139	228	P.139	228					98	315	FB-146	319			FB-135	328				
P.139	228	01200	288					98	315	FB-146	319			FB-135	328				
P.139	228			DF-8	295			98	315	FB-146	319			FB-135	328				
P.139	228	0278	286	DF-19	299														
P.139	228	P.193	247																
P.139	228	P.139	228																
P.139	228	P.193	247	DF-19	299														
P.139	228	P.139	228																
P.259	277																		
P.158	233	P.184	243			DF-8	295												
P.158	233	P.184	243			DF-8	295												
		P.245	270																
		P.245	270																
		P.245	270																

MARCA - MODELLO MAKE - MODEL



Serie
Dischi Rivestiti
Friction Plate Kit



RACING
Serie
Dischi Rivestiti
Friction Plate Kit



Serie Completa
Dischi Frizione
Clutch Plates
Complete Set



RACING
Serie Completa
Dischi Frizione
Clutch Plates
Complete Set



Frizione
Antisaltemento
Slipper Clutches



Carter Frizione
Clutch Covers

BENELLI	CC	MY	COD	PAG	COD	PAG	COD	PAG	COD	PAG	COD	PAG	COD	PAG
VELVET DUSK	400	03												
BX	450	07												
500	500	78												
500 LS	500	78												
650	650	82												
650 SPORT	650	78												
650 T	650	78												
SEI 750	750	76												
TRE-K	899	07												
SEI 900	900	78												
TORNADO	900	02												
TORNADO 3	900	03	05											
TNT	1130	06												
TNT	1130	05												
TNT SPORT	1130	04	07											
TNT TITANIUM	1130	05												
TNT TITANIUM	1130	06												
TNT TORNADO NAKED 3	1130	07												
TORNADO 3	1130	06												
TRE-K	1130	06												
TRE-K AMAZONAS	1130	07												
BETA	CC	MY												
ALP	50	89	91											
ALP	50	92	93											
ALP	50	94												
ARK	50	96												
ARK L.C.	50	97												
CHRONO	50	94												
EIKON	50	99	06											
KR	50	86												
KR	50	87	88											
KR	50	89												
KR ADVENTURE	50	87												
KR TWIN	50	88												
MX	50	92												
MX ENDURO	50	92												
PRO RACE	50	05												
QUADRA	50	97	01											
REV	50	00	07											
RK 6	50	94	96											
RK 6 ENDURO	50	97	02	FB-132	142	FB-132/M	142	FB-140	178	FB-140/C	178			
RK 6 T SUPERMOTARD	50	00		FB-132	142	FB-132/M	142	FB-140	178	FB-140/C	178			
RR	50	00	05	FB-132	142	FB-132/M	142	FB-140	178	FB-140/C	178			
RR - T	50	03		FB-132	142	FB-132/M	142	FB-140	178	FB-140/C	178			
RR 50 ENDURO	50	05												
RR 50 SUPERMOTARD	50	08												
RR 50 SUPERMOTARD ALU	50	04												
RR ENDURO ALU	50	03		FB-132	142	FB-132/M	142	FB-140	178	FB-140/C	178			
RR ENDURO ALU	50	04	07	FB-132	142	FB-132/M	142	FB-140	178	FB-140/C	178			
RR MOTARD ALU	50	03		FB-132	142	FB-132/M	142	FB-140	178	FB-140/C	178			
RR MOTARD ALU	50	04	07	FB-132	142	FB-132/M	142	FB-140	178	FB-140/C	178			
RV	50	88												
SR 34	50	89												
ST	50	94												
SYNT	50	92												
TEMPO	50	98	02											
TEMPO 13	50	94	97											
TR 33	50	86												
TR 34	50	88												
TR 34 CAMPIONATO	50	89												

FRENI - BRAKES

VALVOLE - REEDS

COLLETTORI INTAKE MANIFOLDS

FERMACOPERTONI TIRE LOCKS

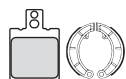

Pastiglie/Ganasce Anteriori
Front Brake Pads/Shoes

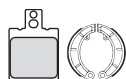

Pastiglie/Ganasce Posteriori
Rear Brake Pads/Shoes



Dischi Freno Anteriori
Front Brake Disk



Dischi Freno Posteriori
Rear Brake Disk



Lamelle
Reeds



Valvole Lamellari
Reed Valve



Valvola Power Reed
Power Reed Valve



Collettori Aspirazione
Intake Manifolds



Fermacopertoni Anteriori
Front Tire Locks



Fermacopertoni Posteriori
Rear Tire Locks

COD	PAG	COD	PAG	COD	PAG	COD	PAG	COD	PAG	COD	PAG	COD	PAG	COD	PAG	COD	PAG	COD	PAG
P.158	233	P.184	243																
P.143	230	P.172	238																
		P.245	270																
		P.245	270																
		P.245	270																
		P.245	270																
		P.245	270																
P.245	270																		
P.168	236	P.186	244																
P.245	270																		
P.168	236	P.012	208																
P.211	256	P.186	244																
P.211	256	P.186	244																
P.168	236	P.186	244																
P.211	256	P.186	244																
P.168	236	P.186	244																
P.211	256	P.186	244																
P.168	236	P.186	244																
P.211	256	P.186	244																
P.168	236	P.186	244																
P.211	256	P.186	244																
P.168	236	P.186	244																
P.168	236	P.186	244																
P.065	213							29	312										
P.065	213	P.098	222					29	312										
P.065	213							29	312										
P.139	228	01200	288					98	315	FB-146	319			FB-135	328				
P.139	228	P.139	228	DF-1	292	DF-1	292	98	315	FB-146	319			FB-135	328				
P.098	222	01200	288	DF-1	292			98	315	FB-146	319			FB-135	328				
P.065	213	P.065	213	DF-8	295	DF-8	295	98	315	FB-146	319			FB-135	328				
P.012	208							29	312										
P.098	222							29	312										
P.065	213							29	312										
P.098	222							29	312										
P.012	208	P.012	208																
P.098	222	P.098	222																
P.065	213	P.065	213																
P.065	213	P.200	250																
P.139	228			DF-8	295			98	315	FB-146	319			FB-135	328				
P.065	213	P.065	213																
P.133	227	P.098	222																
P.133	227	P.065	213																
P.065	213	P.065	213																
P.065	213	P.065	213																
P.065	213																		
		P.237	266																
		P.237	266																
		P.237	266																
P.199	250	P.198	249																
P.133	227	P.065	213																
P.199	250	P.198	249																
P.133	227	P.065	213																
P.071	215																		
P.065	213																		
P.065	213																		
P.065	213							29	312										
P.139	228	01200	288	DF-1	292			98	315	FB-146	319			FB-135	328				
P.098	222	01200	288	DF-1	292			98	315	FB-146	319			FB-135	328				
P.071	215																		
P.071	215							29	312										
P.065	213							29	312										

MARCA - MODELLO MAKE - MODEL



Serie
Dischi Rivestiti
Friction Plate Kit



RACING
Serie
Dischi Rivestiti
Friction Plate Kit



Serie Completa
Dischi Frizione
Clutch Plates
Complete Set



RACING
Serie Completa
Dischi Frizione
Clutch Plates
Complete Set



Frizione
Antisaltemento
Slipper Clutches



Carter Frizione
Clutch Covers

BETA	CC	MY	COD	PAG	COD	PAG	COD	PAG	COD	PAG	COD	PAG	COD	PAG
TR 35	50	89												
TREKKING	50	88												
VRS	50	86												
ZERO	50	94												
EVO	80	09												
REV	80	00	07											
ALP	125	00	04											
ALP	125	05												
ALP 125 4T	125	06												
EIKON	125	00	05											
EVO	125	09												
JONATHAN	125	00	01											
JONATHAN	125	02												
KR	125	86												
RR	125	06												
RR 125 4T	125	05												
RR 125 4T RE	125	08												
RR 125 ENDURO 4T EU3	125	08												
RR 125 ENDURO EU3	125	07												
RR 125 MOTARD 4T EU3	125	08												
RR 125 MOTARD EU3	125	07												
SYNT	125	94												
TR 32	125	86												
TR 34	125	88	BT-55	136										
TR 34 R CAMPIONATO	125	89	BT-55	136										
TR 35	125	91	BT-55	136										
URBAN 125	125	08												
ZERO	125	92	BT-55	136										
EIKON	150	00	05											
ALP	200	00	04											
ALP	200	00												
ALP	200	05												
ALP 200 4T	200	06												
REV 3	200	00	05											
REV 3	200	06												
URBAN 200	200	08												
ALP	240	96	BT-55	136										
ST	240	92	BT-55	136										
TR 33	240	86												
TR 33 TREKKING	240	88												
TR 35 REVERSE	240	89												
AFRICA	250	86												
ALP	250	97												
CR	250	83												
EVO	250	09												
KR	250	86												
KR RALLY	250	87												
REV 3	250	00	04	BT-68	136			BT-62	170					
REV 3	250	05	07	BT-68	136			BT-62	170					
RR ENDURO	250	05	07											
TECHNO	250	94		BT-68	136			BT-62	170					
SYNT	260	92	93	BT-55	136									
SYNT	260	94		BT-55	136									
TR 34	260	88												
TR 34 R CAMPIONATO	260	88		BT-55	136									
TR 34 R SUPER TRIAL	260	89		BT-55	136									
TR 35 REVERSE	260	90		BT-55	136									
ZERO	260	89	92	BT-55	136									
ZERO	260	98		BT-55	136									
ZERO GARA	260	93		BT-55	136									

FRENI - BRAKES

VALVOLE - REEDS

COLLETTORI INTAKE MANIFOLDS

FERMACOPERTONI TIRE LOCKS

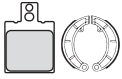

Pastiglie/Ganasce Anteriore
Front Brake Pads/Shoes

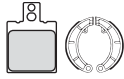

Pastiglie/Ganasce Posteriori
Rear Brake Pads/Shoes



Dischi Freno Anteriore
Front Brake Disk



Dischi Freno Posteriori
Rear Brake Disk



Lamelle
Reeds



Valvole Lamellari
Reed Valve



Valvola Power Reed
Power Reed Valve



Collettori Aspirazione
Intake Manifolds



Fermacopertoni Anteriore
Front Tire Locks



Fermacopertoni Posteriori
Rear Tire Locks

COD	PAG	COD	PAG	COD	PAG	COD	PAG	COD	PAG	COD	PAG	COD	PAG	COD	PAG	COD	PAG	COD	PAG
P.065	213							29	312										
P.071	215																		
P.071	215																		
P.065	213							29	312										
P.199	250																		
P.065	213	P.065	213																
P.065	213	P.065	213																
P.158	233																		
		P.237	266																
P.012	208	P.184	243																
P.199	250																		
P.067	214	P.172	238																
P.067	214																		
P.012	208																		
P.158	233	P.205	253																
		P.237	266																
		P.237	266																
		P.237	266																
		P.237	266																
		P.237	266																
		P.237	266																
P.065	213																		
P.071	215																		
P.071	215	P.098	222					08	310	MF-102	321								
P.065	213							08	310	MF-102	321								
P.065	213							08	310	MF-102	321								
		P.237	266																
P.065	213							08	310	MF-102	321								
		P.184	243	DF-2	292														
P.065	213	P.065	213																
P.065	213	P.205	253																
P.158	233																		
		P.237	266																
P.199	250	P.199	250																
P.199	250																		
		P.237	266																
P.065	213	P.012	208					08	310	MF-102	321								
P.065	213																		
P.071	215																		
P.071	215																		
P.065	213																		
P.012	208																		
P.065	213	P.065	213																
P.012	208																		
P.199	250																		
P.012	208																		
P.012	208																		
P.199	250	P.199	250																
P.199	250																		
P.190	246	P.205	253																
P.065	213																		
P.065	213							08	310	MF-102	321								
P.065	213							08	310	MF-102	321								
P.071	215																		
P.065	213							08	310	MF-102	321								
P.065	213	P.065	213					08	310	MF-102	321								
P.065	213							08	310	MF-102	321								
P.065	213							08	310	MF-102	321								
P.065	213	P.065	213					08	310	MF-102	321								
P.065	213							08	310	MF-102	321								

MARCA - MODELLO MAKE - MODEL



Serie
Dischi Rivestiti
Friction Plate Kit



RACING
Serie
Dischi Rivestiti
Friction Plate Kit



Serie Completa
Dischi Frizione
Clutch Plates
Complete Set



RACING
Serie Completa
Dischi Frizione
Clutch Plates
Complete Set



Frizione
Antisaltemento
Slipper Clutches



Carter Frizione
Clutch Covers

BETA	CC	MY	COD	PAG	COD	PAG	COD	PAG	COD	PAG	COD	PAG	COD	PAG
REV 3	270	00	04	BT-68	136			BT-62	170					
REV 3	270	05	07	BT-68	136			BT-62	170					
EVO	290	09												
EVO	300	09												
ALP 350 4.0	350	04												
EURO	350	00	01											
EURO	350	02												
EURO	350	03	06											
JONATHAN	350	03	06											
M4 MOTARD	350	07												
MOTARD 350 4.0	350	04												
ALP 4.0	400	04												
MOTARD 4.0	400	04												
RR ENDURO	400	05	07											
RR ENDURO	450	05	07											
RR ENDURO	525	05	07											
BIMOTA	CC	MY												
YB 7	400	89												
V DUE	500	98												
V DUE EVOLUTION	500	00												
BELLARIA	600	90												
BELLARIA 600 SPORT	600	91												
YB9 SUPERSPORT	600	93												
BBI SUPERMONO	650	95												
DBI RS	750	87												
SB 6	750	94												
YB 4	750	87												
YB 4	750	89												
TESI 851 1D	851	91												
TESI ID	851	91												
DB 4	900	99												
MANTRA	900	95												
DB 2 H.F.-SR-INIEZIONE	904	93												
TESI I D SR-ES-EF	904	93												
TESI 906 1D	906	91												
DB 5 MILLE	992	05		DU-113	139			DU-107	173					
TESI II D	992	04	06	DU-113	139			DU-107	173					
SB 8 R SPECIAL	996	99												
SB8 K SANTAMONICA	996	06		DU-113	139			DU-107	173					
1000 all models >1988	1000													
DIECI	1000	91												
DIECI BIPOSTO	1000	92												
SB 3 1000	1000	83												
YB 6	1000	87												
YB 6	1000	89												
YB 8	1000	90												
YB 8 EVOLUTION	1000	93												
YB 8 EX UP	1000	91												
YB 8 FURANO	1000	92												
YB 10 DIECI 1002	1002	91												
DB 5	1078	06	07	DU-116	139			DU-117	174					
DB 5 R	1078	06	07	DU-116	139			DU-118	175					
DB 6 DELIRIO	1078	07		DU-116	139			DU-117	174					
TESI III D	1078	07		DU-116	139			DU-118	175					
SB 6	1100	96												
SB 7	1100	94												
TUATARA	1100	90												
DB9 BRIVIDO S	1198	11												
DB9 BRIVIDO SC	1198	11												
YB 5	1200	87												

FRENI - BRAKES

VALVOLE - REEDS

COLLETTORI INTAKE MANIFOLDS

FERMACOPERTONI TIRE LOCKS

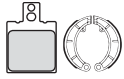

Pastiglie/Ganasce Anteriori
Front Brake Pads/Shoes

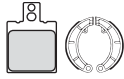

Pastiglie/Ganasce Posteriori
Rear Brake Pads/Shoes



Dischi Freno Anteriore
Front Brake Disk



Dischi Freno Posteriori
Rear Brake Disk



Lamelle
Reeds



Valvole Lamellari
Reed Valve



Valvola Power Reed
Power Reed Valve



Collettori Aspirazione
Intake Manifolds



Fermacopertoni Anteriore
Front Tire Locks



Fermacopertoni Posteriori
Rear Tire Locks

COD	PAG	COD	PAG	COD	PAG	COD	PAG	COD	PAG	COD	PAG	COD	PAG	COD	PAG	COD	PAG	COD	PAG
P.199	250	P.199	250																
P.199	250																		
P.065	213																		
P.199	250																		
		P.237	266																
P.085	219	P.172	238																
P.085	219																		
P.067	214	P.079	218																
P.067	214	P.079	218																
		P.205	253																
		P.237	266																
P.158	233																		
		P.205	253																
P.190	246	P.205	253																
P.190	246	P.205	253																
P.190	246	P.205	253																
P.085	219																		
P.067	214	P.012	208																
P.168	236	P.012	208																
P.067	214	P.012	208																
		P.245	270																
P.067	214	P.012	208																
P.067	214																		
P.067	214	P.012	208																
P.067	214	P.012	208																
P.067	214	P.012	208																
P.085	219																		
		P.245	270																
P.067	214	P.012	208																
P.168	236	P.012	208																
P.067	214	P.012	208																
P.067	214	P.012	208																
P.067	214	P.012	208																
		P.245	270																
P.211	256	P.186	244																
P.067	214	P.012	208																
P.168	236	P.012	208																
P.211	256	P.012	208																
P.245	270	P.245	270																
P.067	214																		
P.067	214	P.012	208																
P.245	270	P.245	270																
P.067	214	P.012	208																
P.085	219																		
P.067	214	P.012	208																
P.067	214	P.012	208																
P.067	214	P.012	208																
P.067	214	P.012	208																
		P.245	270																
P.211	256	P.186	244																
P.211	256	P.186	244																
P.211	256	P.186	244																
P.211	256	P.186	244																
P.067	214	P.012	208																
		P.012	208																
		P.012	208																
P.238	267																		
P.238	267																		
		P.012	208																

MARCA - MODELLO MAKE - MODEL



Serie
Dischi Rivestiti
Friction Plate Kit



RACING
Serie
Dischi Rivestiti
Friction Plate Kit



Serie Completa
Dischi Frizione
Clutch Plates
Complete Set



RACING
Serie Completa
Dischi Frizione
Clutch Plates
Complete Set



Frizione
Antisaltemento
Slipper Clutches



Carter Frizione
Clutch Covers

BIMOTA	CC	MY	COD	PAG	COD	PAG	COD	PAG	COD	PAG	COD	PAG	COD	PAG
YB 5 FS	1200	87												
BLATA	CC	MY												
ENDURO 125	125	07												
MOTARD 125	125	07												
BMW	CC	MY												
C1	125	99	03											
C1	200	01	03											
G 450 ENDURO	450	08												
G 450 SMR	450	09												
G 450 X	450	09												
R 45 450	450	81												
F 650	650	93	00	BR-76	136			BR-77	169					
F 650 CS / SCARVER	650	00	06	BR-76	136			BR-77	169					
F 650 GS	650	93	07	BR-76	136			BR-77	169					
F 650 GS	650	08	09											
F 650 GS	650	10												
F 650 GS DAKAR	650	93	07	BR-76	136			BR-77	169					
F 650 ST	650	93	00	BR-76	136			BR-77	169					
G 650 XCHALLENGE	650	07		BR-76	136			BR-77	169					
G 650 XCOUNTRY	650	07		BR-76	136			BR-77	169					
G 650 XCOUNTRY	650	07	09											
G 650 XMOTO	650	07		BR-76	136			BR-77	169					
G 650 XMOTO	650	07	09											
R 65 650	650	81												
R 65 650 GS	650	87												
R 65 650 LS	650													
R 65 R	650	93		BR-76	136			BR-77	169					
K 75 750	750	90												
K 75 750	750													
K 75 750 RT	750	91												
K 75 750 S	750	88												
K 75 750 S	750													
K 75 750 pinza ABS	750	91												
F 800 R	800	09												
R 80 800 GS/PARISDAKAR	800	81												
R 80 800 all models	800	82												
R 80 800 all models	800	85												
R 800	800	15												
R 850 R	850	04												
R 850 R ROADSTER	850	95	00											
R 850 R ROADSTER	850	01												
R 850 R ROADSTER	850	01												
R 850 RT	850	06												
R 850 RT ABS	850	01												
K 1 1000	1000	89												
K 100 1000 LT	1000	88												
K 100 1000 RS	1000	88												
K 100 1000 RS	1000	90												
K 100 1000 all models	1000													
K 100 1000 pinza ABS	1000	91												
R 100 1000 RS RT CS	1000	81												
R 100 1000 all models	1000	81												
R 100 1000 all models *	1000	81												
R 100 R CLASSIC - MYSTIC	1000	95												
S 1000 RR	1000	10												
XR 1000	1000	15												
R 1100 R ROADSTER	1100	95												
R 1100 RS NO ABS	1100	95												
R 1100 RT ABS	1100	94	01											
R 1100 RT NO ABS	1100	94	01											

FRENI - BRAKES

VALVOLE - REEDS

COLLETTORI INTAKE MANIFOLDS

FERMACOPERTONI TIRE LOCKS

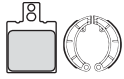

Pastiglie/Ganasce Anteriori
Front Brake Pads/Shoes

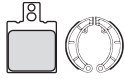

Pastiglie/Ganasce Posteriori
Rear Brake Pads/Shoes



Dischi Freno Anteriore
Front Brake Disk



Dischi Freno Posteriori
Rear Brake Disk



Lamelle
Reeds



Valvole Lamellari
Reed Valve



Valvola Power Reed
Power Reed Valve



Collettori Aspirazione
Intake Manifolds



Fermacopertoni Anteriore
Front Tire Locks



Fermacopertoni Posteriori
Rear Tire Locks

COD	PAG	COD	PAG	COD	PAG	COD	PAG	COD	PAG	COD	PAG	COD	PAG	COD	PAG	COD	PAG	COD	PAG
		P.045	211																
P.246	271																		
P.246	271																		
P.192	247	P.172	238																
P.192	247	P.172	238																
P.143	230	P.203	252																
		P.203	252																
		P.203	252																
P.245	270																		
P.192	247	P.172	238																
P.192	247	P.172	238																
P.192	247	P.172	238																
P.172	238																		
		P.172	238																
P.192	247	P.172	238																
P.192	247	P.172	238																
P.192	247	P.172	238																
P.192	247	P.172	238																
P.168	236	P.172	238																
P.245	270																		
P.245	270																		
P.245	270																		
		P.245	270																
P.245	270																		
		P.245	270																
P.245	270																		
P.245	270																		
P.245	270																		
P.233	264																		
P.235	265	P.231	263																
		P.231	263																
P.230	263	P.231	263																
P.230	263																		
P.230	263	P.231	263																
P.230	263																		
		P.245	270																
		P.245	270																
		P.245	270																
		P.245	270																
P.245	270	P.245	270																
		P.245	270																
		P.245	270																
P.245	270	P.245	270																
P.245	270	P.245	270																
P.211	256	P.172	238																
P.233	264																		
		P.231	263																
		P.231	263																
		P.231	263																
		P.231	263																

MARCA - MODELLO MAKE - MODEL



Serie
Dischi Rivestiti
Friction Plate Kit



RACING
Serie
Dischi Rivestiti
Friction Plate Kit



Serie Completa
Dischi Frizione
Clutch Plates
Complete Set



RACING
Serie Completa
Dischi Frizione
Clutch Plates
Complete Set



Frizione
Antisaltemento
Slipper Clutches



Carter Frizione
Clutch Covers

BMW	CC	MY	COD	PAG	COD	PAG	COD	PAG	COD	PAG	COD	PAG	COD	PAG
R 1100 S ABS	1100	01												
R 1100 S ABS	1100	01												
R 1100 S NO ABS	1100	01												
R 1100 Sno ABS	1100	01												
H2 ENDURO	1150	05												
H2 MEGAMOTO	1150	07												
H2 SPORT	1150	08												
HS SM	1150	06												
R 1150 GS	1150	00	01											
R 1150 GS	1150	02												
R 1150 R	1150	01												
R 1150 R ROADSTER	1150	01												
R 1150 R ROADSTER	1150	01												
R 1150 R con freno integrale	1150	01												
R 1150 ROCKESTER	1150	03												
R 1150 RS	1150	01												
R 1150 RS con freno integrale	1150	01												
R 1150 RT	1150	01												
HP2 1200 MEGAMOTO	1200	07												
K 1200 RS	1200	97												
K 1200 RS	1200	01												
K 1200 GT	1200	02	05											
K 1200 GT ABS integrale	1200	08												
K 1200 GT IZQ/LEFT	1200	06												
K 1200 LT ABS integrale	1200	02												
K 1200 R	1200	05												
K 1200 R	1200	05												
K 1200 R SPORT	1200	07												
K 1200 R SPORT	1200	07												
K 1200 RS ABS	1200	97	00											
K 1200 RT	1200	06												
K 1200 S	1200	04												
K 1200 S	1200	05												
K 1200 ST	1200	06												
R 1200 C AVANTGARDE	1200	00												
R 1200 C CLASSIC	1200	03												
R 1200 C INDEPENDENT	1200	01												
R 1200 C INDEPENDENT	1200	03												
R 1200 C MONTAUK	1200	04												
R 1200 C MONTAUK	1200	04												
R 1200 CL	1200	03												
R 1200 CRUISER	1200	97												
R 1200 GS	1200	04	12											
R 1200 GS	1200	04												
R 1200 GS	1200	13												
R 1200 GS	1200	13												
R 1200 GS	1200	14												
R 1200 GS ADVENTURE	1200	06												
R 1200 GS ADVENTURE	1200	14												
R 1200 LT con freno integrale	1200	02												
R 1200 NINET	1200	14												
R 1200 R	1200	05												
R 1200 R	1200	11												
R 1200 R	1200	06	10											
R 1200 R S	1200	15												
R 1200 RT	1200	05												
R 1200 RT	1200	06												
R 1200 RT	1200	14												
R 1200 RT SE	1200	10												
R 1200 S	1200	06												

FRENI - BRAKES

VALVOLE - REEDS

COLLETTORI INTAKE MANIFOLDS

FERMACOPERTONI TIRE LOCKS

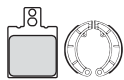

Pastiglie/Ganasce Anteriore
Front Brake Pads/Shoes

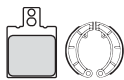

Pastiglie/Ganasce Posteriori
Rear Brake Pads/Shoes



Dischi Freno Anteriore
Front Brake Disk



Dischi Freno Posteriori
Rear Brake Disk



Lamelle
Reeds



Valvole Lamellari
Reed Valve



Valvola Power Reed
Power Reed Valve



Collettori Aspirazione
Intake Manifolds



Fermacopertoni Anteriore
Front Tire Locks



Fermacopertoni Posteriori
Rear Tire Locks

COD	PAG	COD	PAG	COD	PAG	COD	PAG	COD	PAG	COD	PAG	COD	PAG	COD	PAG	COD	PAG	COD	PAG
P.235	265																		
		P.231	263																
		P.231	263																
P.230	263																		
P.192	247	P.231	263																
P.230	263	P.231	263																
		P.231	263																
P.192	247																		
		P.231	263																
P.230	263	P.231	263																
P.235	265																		
		P.231	263																
P.235	265																		
P.235	265																		
		P.231	263																
		P.231	263																
P.235	265																		
P.230	263	P.231	263																
P.230	263																		
		P.245	270																
P.230	263	P.245	270																
P.230	263																		
P.230	263																		
P.230	263																		
P.235	265																		
P.235	265																		
		P.231	263																
P.235	265																		
		P.231	263																
		P.231	263																
P.230	263	P.231	263																
P.230	263	P.231	263																
P.230	263																		
P.230	263	P.231	263																
		P.231	263																
P.235	265																		
		P.231	263																
P.235	265																		
		P.231	263																
P.235	265																		
		P.231	263																
P.230	263	P.231	263																
P.230	263																		
P.233	264																		
P.233	264																		
P.233	264																		
P.230	263	P.231	263																
P.233	264																		
P.235	265																		
P.233	264																		
P.235	265																		
		P.231	263																
		P.231	263																
P.233	264																		
P.230	263																		
P.230	263																		
P.233	264																		
P.233	264																		
P.230	263	P.231	263																
		P.231	263																

MARCA - MODELLO MAKE - MODEL



Serie
Dischi Rivestiti
Friction Plate Kit



RACING
Serie
Dischi Rivestiti
Friction Plate Kit



Serie Completa
Dischi Frizione
Clutch Plates
Complete Set



RACING
Serie Completa
Dischi Frizione
Clutch Plates
Complete Set



Frizione
Antisaltemento
Slipper Clutches



Carter Frizione
Clutch Covers

BMW	CC	MY	COD	PAG	COD	PAG	COD	PAG	COD	PAG	COD	PAG	COD	PAG
R 1200 S	1200	06												
R 1200 ST	1200	05												
R 1200 ST	1200	06												
K 1300 GT	1300	09												
K 1300 GT	1300	09												
K 1300 R	1300	09												
K 1300 R	1300	09												
K 1300 R DYNAMIC	1300	11												
K 1300 S	1300	09												
K 1300 S	1300	09												
K 1600 GT	1600	11												
K 1600 GT	1600	11												
K 1600 GTL	1600	11												
K 1600 GTL	1600	11												
BOMBARDIER ATV	CC	MY												
RALLY 200 2x4	200	03												
BUELL	CC	MY												
BLAST	500	01												
XB9R FIREBOLT	984	02												
XB9S LIGHTNING	984	03												
XB9SX CITY X	984	05												
M2 CYCLONE	1200	98	02											
S1 LIGHTNING	1200	98	02											
S1 WHITELIGHTNING	1200	98	02											
S3 THUNDERBOLD	1200	98	02											
X1 LIGHTNING	1200	01	02											
XB12R FIREBOLT	1200	04												
XB12S LIGHTNING	1200	04												
XB12SS LIGHTNING LONG	1200	06												
XB12STT SUPER TT	1200	07												
XB12X ULYSSES	1200	06												
CAGIVA	CC	MY												
CITY	50	92	94											
COCIS	50	88		MA-162	155									
K 3	50	92		MA-162	155									
LUCKY EXPLORER	50	88		MA-162	155									
MANTIS	50	99												
NUVOLA	50	00												
PASSING	50	95												
PRIMA	50	92	94	MA-162	155									
STELLA	50	97												
STRADA PRIMA	50	92		MA-162	155									
SUPER CITY	50	92		MA-162	155									
W 4	50	92	95	MA-162	155									
PRIMA	75	92												
SUPER CITY	75	92												
COCIS	80	89												
LR	80	83												
SUPER CITY	80	92												
ALETTA ORO S 2	125	86		MA-66	155			MA-84	188					
BLUES	125	88		MA-78	155			MA-85	188					
BLUES	125	93		MA-78	155			MA-85	188					
CRUISER	125	87	88	MA-66	155			MA-84	188					
CUCCILOLO	125	99												
E 2	125	86												
ELECTRA	125	88												
ELEFANT	125	81	84	MA-78	155			MA-85	188					
ELEFANT	125	85	87	MA-78	155			MA-85	188					
ELEFANT 3	125	88		MA-78	155			MA-85	188					
FRECCIA	125	87		MA-66	155			MA-84	188					

FRENI - BRAKES

VALVOLE - REEDS

COLLETTORI INTAKE MANIFOLDS

FERMACOPERTONI TIRE LOCKS

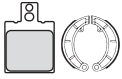

Pastiglie/Ganasce
Anteriore
Front Brake
Pads/Shoes

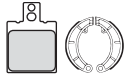

Pastiglie/Ganasce
Posteriore
Rear Brake
Pads/Shoes



Dischi Freno
Anteriore
Front Brake Disk



Dischi Freno
Posteriore
Rear Brake Disk



Lamelle
Reeds



Valvole Lamellari
Reed Valve



Valvola Power Reed
Power Reed Valve



Collettori
Aspirazione
Intake Manifolds



Fermacopertoni
Anteriore
Front Tire Locks



Fermacopertoni
Posteriore
Rear Tire Locks

COD	PAG	COD	PAG	COD	PAG	COD	PAG	COD	PAG	COD	PAG	COD	PAG	COD	PAG	COD	PAG	COD	PAG
P.230	263																		
		P.231	263																
P.230	263																		
P.230	263																		
P.230	263	P.231	263																
		P.231	263																
P.235	265																		
P.235	265																		
P.230	263	P.231	263																
P.230	263																		
P.235	265																		
		P.231	263																
		P.231	263																
P.235	265																		
P.260	277																		
P.108	224	P.103	223																
		P.103	223																
		P.103	223																
		P.103	223																
		P.103	223																
		P.103	223																
		P.103	223																
		P.103	223																
		P.103	223																
		P.103	223																
		P.103	223																
		P.103	223																
		P.103	223																
		P.103	223																
		P.103	223																
		P.103	223																
P.012	208	01200	288	DF-4	293			77	314					FB-134	327				
P.012	208							24	312										
P.012	208							24	312										
P.139	228																		
P.139	228																		
P.188	245			DF-4	293			77	314					FB-134	327				
		P.144	231					24	312										
P.188	245	P.188	245																
								24	312										
		P.012	208					24	312										
P.012	208							24	312										
		P.012	208					24	312					MA-205	328				
								24	312										
P.012	208																		
		P.012	208					24	312										
								13	311					PWR-1	322				
P.074	216	P.012	208					13	311					PWR-1	322				
P.074	216							13	311					PWR-1	322				
								13	311					PWR-1	322				
P.173	240																		
														PWR-1	322				
														PWR-1	322				
								13	311					PWR-1	322				
								13	311					PWR-1	322				
								13	311					PWR-1	322				
		P.012	208					13	311					PWR-1	322				

MARCA - MODELLO MAKE - MODEL



Serie
Dischi Rivestiti
Friction Plate Kit



RACING
Serie
Dischi Rivestiti
Friction Plate Kit



Serie Completa
Dischi Frizione
Clutch Plates
Complete Set



RACING
Serie Completa
Dischi Frizione
Clutch Plates
Complete Set



Frizione
Antisaltamento
Slipper Clutches



Carter Frizione
Clutch Covers

CAGIVA	CC	MY	COD	PAG	COD	PAG	COD	PAG	COD	PAG	COD	PAG	COD	PAG
FRECCIA C 10	125	88	MA-174	156			MA-175	189	MA-175/C	189				
FRECCIA C 10 ANNIVERSARY	125	89	MA-174	156			MA-175	189	MA-175/C	189				
FRECCIA C 12 R	125	89	MA-174	156			MA-175	189	MA-175/C	189				
FRECCIA C 9	125	88	MA-66	155			MA-84	188						
K 7	125	91	MA-174	156			MA-175	189	MA-175/C	189				
MITO	125	90	92	MA-174	156			MA-175	189	MA-175/C	189			
MITO EDDY	125	93	MA-174	156			MA-175	189	MA-175/C	189				
MITO SPORT PRODUCTION	125	91	MA-174	156			MA-175	189	MA-175/C	189				
N 90	125	91	MA-174	156			MA-175	189	MA-175/C	189				
PASSING	125	94												
PLANET	125	98	03	MA-174	156			MA-175	189	MA-175/C	189			
RAPTOR	125	03	MA-174	156			MA-175	189	MA-175/C	189				
ROADSTER	125	98	99	MA-174	156			MA-175	189	MA-175/C	189			
SST	125	81												
SUPER CITY	125	93	00	MA-174	156			MA-175	189	MA-175/C	189			
TAMANACO	125	89	MA-174	156			MA-175	189	MA-175/C	189				
W 8	125	92	98	MA-174	156			MA-175	189	MA-175/C	189			
W 8 PRO ACTION	125	91	MA-174	156			MA-175	189	MA-175/C	189				
WMX	125	85	MA-66	155			MA-84	188						
WMX	125	87												
WMX	125	88	MA-174	156			MA-175	189	MA-175/C	189				
WMX	125	90	MA-174	156			MA-175	189	MA-175/C	189				
WSTX ALETTA ROSSA	125	83	MA-78	155			MA-85	188						
ALETTA ELECTRA	200	83	MA-78	155			MA-85	188						
ELEFANT	200	88	MA-174	156			MA-175	189	MA-175/C	189				
ELEFANT	200	89	MA-174	156			MA-175	189	MA-175/C	189				
ALA BLU	250	83												
MXR	250	82												
SST ALA VERDE	250	81												
VRX	250	83												
WMX	250	88												
WMX	250	91												
WMX GP	250	82	MA-66	155			MA-84	188						
ALA BLU	350	83												
ALA ROSSA SXT	350	82												
ALA VERDE SST	350	83												
ALAZZURRA	350	84												
ALAZZURRA GT	350	87												
ELEFANT LUCKY EXPLORER	350	87	DU-83	138			DU-85	171						
SX	350	83												
W 12	350	93	HU-39	150			HU-50	185	HU-50/C	186				
CANYON	500	96	00	HU-39	150			HU-50	185	HU-50/C	186			
ENDURO	500	86												
MITO	500	07												
RIVER	500	00	HU-39	150			HU-50	185	HU-50/C	186				
WMX	500	86	MA-146	155			MA-147	188						
WMX	500	87												
CANYON	600	96	99	HU-39	150			HU-50	185	HU-50/C	186			
RIVER	600	00	HU-39	150			HU-50	185	HU-50/C	186				
W 16	600	95	HU-39	150			HU-50	185	HU-50/C	186				
ALAZZURRA GT	650	87	DU-45	137			DU-50	171						
ELEFANT	650	87	DU-45	137			DU-50	171						
PARIGI DAKAR	650	86	DU-45	137			DU-50	171						
RAPTOR	650	01												
TOURING	650	86	DU-45	137			DU-50	171						
V-RAPTOR	650	01												
DAKAR	750	87	DU-83	138			DU-85	171						
ELEFANT	750	87	DU-83	138			DU-85	171						
ELEFANT	750	88	89	DU-83	138			DU-85	171					
ELEFANT	750	94	DU-89	138			DU-90	172						

FRENI - BRAKES

VALVOLE - REEDS

COLLETTORI INTAKE MANIFOLDS

FERMACOPERTONI TIRE LOCKS

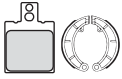

Pastiglie/Ganasce Anteriori
Front Brake Pads/Shoes

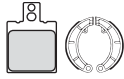

Pastiglie/Ganasce Posteriori
Rear Brake Pads/Shoes



Dischi Freno Anteriore
Front Brake Disk



Dischi Freno Posteriori
Rear Brake Disk



Lamelle
Reeds



Valvole Lamellari
Reed Valve



Valvola Power Reed
Power Reed Valve



Collettori Aspirazione
Intake Manifolds



Fermacopertoni Anteriore
Front Tire Locks



Fermacopertoni Posteriori
Rear Tire Locks

COD	PAG	COD	PAG	COD	PAG	COD	PAG	COD	PAG	COD	PAG	COD	PAG	COD	PAG	COD	PAG	COD	PAG
		P.012	208					13	311			PWR-1	322						
								13	311			PWR-1	322						
								13	311			PWR-1	322						
		P.012	208					13	311			PWR-1	322						
		P.075	217					81	314	MA-189	320	PWR-1	322						
		P.012	208					81	314	MA-189	320	PWR-1	322						
P.067	214	P.012	208					81	314	MA-189	320	PWR-1	322						
		P.012	208					81	314	MA-189	320	PWR-1	322						
								13	311			PWR-1	322						
P.188	245			DF-4	293														
P.067	214	P.012	208									PWR-1	322						
P.067	214	P.012	208					81	314	MA-189	320	PWR-1	322						
												PWR-1	322						
												PWR-1	322						
		P.012	208					81	314	MA-189	320	PWR-1	322						
								13	311			PWR-1	322						
								13	311			PWR-1	322			MA-139	332	MA-152	333
								81	314	MA-189	320	PWR-1	322			MA-139	332	MA-152	333
P.012	208							13	311			PWR-1	322			MA-139	332	MA-152	333
												PWR-1	322			MA-139	332	MA-152	333
												PWR-1	322			MA-139	332	MA-152	333
		P.075	217					81	314			PWR-1	322			MA-139	332	MA-152	333
												PWR-1	322						
												PWR-1	322						
P.012	208							13	311			PWR-1	322			MA-139	332	MA-152	333
								13	311			PWR-1	322			MA-139	332	MA-152	333
P.012	208																		
P.012	208																		
P.012	208																		
P.012	208																		
		P.075	217					16	311	MA-143	320					MA-139	332	MA-152	333
		P.075	217					16	311							MA-139	332	MA-152	333
P.012	208							16	311	MA-143	320					MA-139	332	MA-152	333
P.012	208																		
P.012	208																		
P.012	208																		
P.012	208																		
P.012	208																		
P.012	208																		
P.012	208																		
P.012	208	P.012	208																
P.082	219	P.116	226																
P.012	208																		
P.067	214	P.012	208																
P.067	214	P.012	208																
P.012	208							16	311	MA-143	320								
P.012	208	P.012	208					16	311	MA-143	320								
P.082	219	P.116	226																
P.067	214																		
		P.075	217																
P.074	216	P.012	208																
		P.012	208																
P.074	216	P.012	208																
P.168	236	P.186	244																
P.012	208	P.012	208																
P.168	236	P.186	244																
		P.012	208																
		P.012	208																
P.082	219	P.143	230																

MARCA - MODELLO MAKE - MODEL



Serie
Dischi Rivestiti
Friction Plate Kit



RACING
Serie
Dischi Rivestiti
Friction Plate Kit



Serie Completa
Dischi Frizione
Clutch Plates
Complete Set



RACING
Serie Completa
Dischi Frizione
Clutch Plates
Complete Set



Frizione
Antisaltemamento
Slipper Clutches



Carter Frizione
Clutch Covers

CAGIVA	CC	MY	COD	PAG	COD	PAG	COD	PAG	COD	PAG	COD	PAG	COD	PAG
ELEFANT BIFARO	750	90	93	DU-83	138			DU-85	171					
LUCKY EXPLORER	750	88		DU-83	138			DU-85	171					
CANYON	900	97		DU-56	137			DU-96	172					
ELEFANT	900	90		DU-83	138			DU-85	171					
ELEFANT	900	91		DU-56	137			DU-96	172					
ELEFANT CATALITICA	900	93		DU-56	137			DU-96	172					
ELEFANT I.E.	900	91		DU-56	137			DU-96	172					
GRAN CANYON	900	99												
ELEFANT	906	89		DU-83	138			DU-85	171					
EXTRA-RAPTOR	1000	00	05											
NAVIGATOR	1000	00	05											
RAPTOR	1000	00	05											
V-RAPTOR	1000	00	05											
X3-RAPTOR	1000	03	04											
CPI	CC	MY												
BABY 50 J	50	02												
GTR	50	03												
HUSSAR 50	50	01												
MARS 50	50	01												
OLIVER CITY	50	08												
OLIVER SPORT	50	08												
POPCORN 50	50	02												
GTR/GTS	125	02												
OLIVER SPORT	150	08												
GTR/GTS	180	08												
GTR/GTS	200	02												
XS 250	250	07												
CZ JAWA	CC	MY												
CZ 125 2T	125													
CZ 125 MX	125													
CZ 180	180	92												
TRAIL 300	300	93												
DAELIM	CC	MY												
A FOUR 50	50	06												
E-FIVE	50	03												
HISTORY-S-FIVE	50	01												
TAPO	50	99												
VIVO	50	99												
DELFINO	100	99	01											
DELFINO 125	125	08												
FELLOW	125	97												
HISTORY	125	01												
OTELLO DLX	125	00	02											
ROADWIN	125	04												
ROCKET	125	99												
S2	125	08												
S2	250	08												
ST 250 SECTOR QUAD	250	05												
DERBI	CC	MY												
ATLANTIS	50	99												
BLACK DEVIL	50	04												
COPPA FDX	50	87												
GP 1 L.C.	50	01	04											
GP 1 L.C.	50	05												
GPR R	50	97		DB-12	136			DB-12/M	170					
GPR SPORT	50	96		DB-12	136			DB-12/M	170					
PADDOCK	50	96												
PREDATOR	50	99												
PREDATOR 0.2	50	00												
RECORD	50	98												

FRENI - BRAKES

VALVOLE - REEDS

COLLETTORI INTAKE MANIFOLDS

FERMACOPERTONI TIRE LOCKS

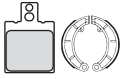

Pastiglie/Ganasce Anteriori
Front Brake Pads/Shoes

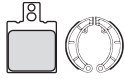

Pastiglie/Ganasce Posteriori
Rear Brake Pads/Shoes



Dischi Freno Anteriore
Front Brake Disk



Dischi Freno Posteriori
Rear Brake Disk



Lamelle
Reeds



Valvole Lamellari
Reed Valve



Valvola Power Reed
Power Reed Valve



Collettori Aspirazione
Intake Manifolds



Fermacopertoni Anteriore
Front Tire Locks



Fermacopertoni Posteriori
Rear Tire Locks

COD	PAG	COD	PAG	COD	PAG	COD	PAG	COD	PAG	COD	PAG	COD	PAG	COD	PAG	COD	PAG	COD	PAG
		P.133	227																
		P.012	208																
P.192	247	P.116	226																
P.082	219	P.116	226																
P.082	219	P.133	227																
P.108	224																		
P.082	219	P.116	226																
P.108	224	P.116	226																
P.082	219	P.116	226																
P.168	236	P.186	244																
P.156	232	P.116	226																
P.168	236	P.186	244																
P.168	236	P.186	244																
P.211	256	P.186	244																
P.260	277																		
		P.139	228																
P.260	277																		
P.260	277																		
		01205	288																
		01205	288																
P.260	277																		
P.158	233	P.139	228																
P.158	233	P.175	240																
P.158	233	P.175	240																
P.158	233	P.139	228																
P.240	268																		
P.245	270																		
P.245	270																		
P.245	270																		
P.245	270																		
P.259	277																		
P.003	208																		
P.003	208	P.003	208																
P.003	208																		
P.003	208																		
P.003	208																		
P.259	277																		
P.003	208																		
P.003	208	P.003	208																
P.003	208	P.003	208																
		P.166	235																
P.108	224																		
P.108	224	P.166	235																
P.108	224	P.166	235																
P.260	277	P.263	279																
P.065	213							90	314										
P.158	233	P.065	213																
P.065	213																		
P.065	213																		
P.065	213	P.065	213																
P.133	227	P.065	213																
P.098	222																		
P.065	213							90	314										
P.065	213	P.065	213					90	314										
P.065	213	P.065	213					90	314										
P.065	213							90	314										

MARCA - MODELLO MAKE - MODEL



Serie
Dischi Rivestiti
Friction Plate Kit



RACING
Serie
Dischi Rivestiti
Friction Plate Kit



Serie Completa
Dischi Frizione
Clutch Plates
Complete Set



RACING
Serie Completa
Dischi Frizione
Clutch Plates
Complete Set



Frizione
Antisaltemento
Slipper Clutches



Carter Frizione
Clutch Covers

DERBI	CC	MY	COD	PAG	COD	PAG	COD	PAG	COD	PAG	COD	PAG	COD	PAG
SENDA	50	93	97	DB-12	136			DB-12/M	170					
SENDA R DRD	50	02		DB-12	136			DB-12/M	170					
SENDA SM DRD	50	02		DB-12	136			DB-12/M	170					
SENDA SM DRD	50	03		DB-12	136			DB-12/M	170					
SENDA SUPERMOTARD	50	98	01	DB-12	136			DB-12/M	170					
SENDA X - TREM R	50	03		DB-12	136			DB-12/M	170					
VARIANT SPORT R	50	94												
GPR	80	90												
GPR	80	92		DB-12	136			DB-12/M	170					
ATLANTIS 0.2	100	00												
ATMOSPHERE	125	99												
BOULERVARD 4T	125	03												
GP 1	125	06												
GPR	125	05												
GPR 125 4T	125	09												
GPR 125 NUDE	125	04												
GPR 125 RACING	125	04												
GPR NUDE	125	05												
PREDATOR	125	99												
SENDA 4T	125	04												
SENDA X - TREM SM	125	04												
BOULERVARD 4T	150	03	05											
PREDATOR	180	99												
BOULERVARD 4T	200	05												
GP 1	250	05												
MULHACEN 659	659	05												
DUCATI	CC	MY												
250 DESMO	250													
350 DESMO	350													
F 3	350	87		DU-45	137			DU-50	171					
INDIANA	350	87		DU-45	137			DU-50	171					
SPORT	350	91		DU-79	137			DU-81	171					
DESMO F 3	400	87												
SCRAMBLER	400	14		DU-128	140			DU-129	176					
SS 400	400	93		DU-89	138			DU-90	172					
SS JUNIOR	400	91		DU-79	137			DU-81	171					
GTV	500	77												
PANTAH	500	85												
600 SL	600	76												
600 TL PANTAH	600	76												
M 600 MONSTER	600	94	97	DU-89	138			DU-90	172					
M 600 MONSTER	600	98	99	DU-105	138			DU-104	173					
M 600 MONSTER	600	99	01	DU-105	138			DU-104	173					
SS 600	600	94		DU-89	138			DU-90	172					
SUPERMONO DESMO 4	600	93												
M620	618	05		DU-111	138			DU-112	174					
M620 DARK	618	05		DU-111	138			DU-112	174					
MONSTER DARK I.E.	618	03		DU-105	138			DU-104	173					
MONSTER I.E.	618	02		DU-105	138			DU-104	173					
MONSTER S I.E.	618	03		DU-105	138			DU-112	174					
SS	618	03		DU-105	138			DU-104	173					
SS	618	04		DU-111	138			DU-112	174					
MULTISTRADA	620	05												
MULTISTRADA DARK	620	05												
650 DESMO	650	87												
DESMO	650	87		DU-45	137			DU-50	171					
INDIANA	650	87		DU-45	137			DU-50	171					
695 MONSTER	695	06		DU-111	138			DU-112	174					
695 MONSTER	695	07												
696 MONSTER	696	08		DU-111	138			DU-112	174					

FRENI - BRAKES

VALVOLE - REEDS

COLLETTORI INTAKE MANIFOLDS

FERMACOPERTONI TIRE LOCKS

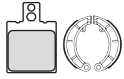

Pastiglie/Ganasce Anteriore
Front Brake Pads/Shoes

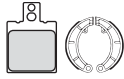

Pastiglie/Ganasce Posteriori
Rear Brake Pads/Shoes



Dischi Freno Anteriore
Front Brake Disk



Dischi Freno Posteriori
Rear Brake Disk



Lamelle
Reeds



Valvole Lamellari
Reed Valve



Valvola Power Reed
Power Reed Valve



Collettori Aspirazione
Intake Manifolds



Fermacopertoni Anteriore
Front Tire Locks



Fermacopertoni Posteriori
Rear Tire Locks

COD	PAG	COD	PAG	COD	PAG	COD	PAG	COD	PAG	COD	PAG	COD	PAG	COD	PAG	COD	PAG	COD	PAG
P.065	213																		
P.133	227	P.065	213																
P.158	233	P.065	213																
P.158	233	P.065	213																
P.065	213																		
P.065	213	P.065	213																
P.065	213																		
P.098	222							75	313										
P.065	213							75	313										
P.133	227																		
P.201	251	0278	286																
P.186	244	P.186	244																
		P.065	213																
P.246	271																		
P.246	271																		
P.246	271																		
		P.065	213																
P.133	227																		
P.158	233	P.065	213																
P.158	233	P.065	213																
P.201	251																		
P.133	227																		
P.201	251																		
P.186	244	P.186	244																
P.232	264																		
P.245	270																		
P.245	270																		
P.012	208	P.012	208																
		P.012	208																
P.067	214	P.012	208																
P.012	208	P.012	208																
		P.012	208																
P.245	270	P.245	270																
P.245	270	P.245	270																
P.067	214																		
P.067	214	P.012	208																
P.168	236	P.012	208																
P.067	214	P.012	208																
P.067	214	P.012	208																
P.143	230	P.186	244																
P.143	230	P.186	244																
P.168	236	P.186	244																
P.168	236	P.186	244																
P.168	236	P.186	244																
P.168	236	P.186	244																
P.168	236	P.186	244																
P.168	236	P.186	244																
P.192	247	P.186	244																
P.168	236	P.186	244																
P.245	270																		
		P.012	208																
P.192	247	P.012	208																

MARCA - MODELLO MAKE - MODEL



Serie
Dischi Rivestiti
Friction Plate Kit



RACING
Serie
Dischi Rivestiti
Friction Plate Kit



Serie Completa
Dischi Frizione
Clutch Plates
Complete Set



RACING
Serie Completa
Dischi Frizione
Clutch Plates
Complete Set



Frizione
Antisaltemento
Slipper Clutches



Carter Frizione
Clutch Covers

DUCATI	CC	MY	COD	PAG	COD	PAG	COD	PAG	COD	PAG	COD	PAG	COD	PAG
696 MONSTER	696	08												
748 BIPOSTO	748	95	97	DU-56	137			DU-96	172			DU-108	194	
748 DESMO 4	748	94		DU-56	137			DU-96	172			DU-108	194	
748 R	748	00		DU-56	137			DU-106	173			DU-108	194	
748 R	748	01	02											
748 R	748	01		DU-56	137			DU-106	173			DU-108	194	
748 SP	748	95	97	DU-56	137			DU-96	172			DU-108	194	
748 SPS	748	98		DU-56	137			DU-96	172			DU-108	194	
749	748	03		DU-113	139			DU-107	173			DU-109	195	
749 BIPOSTO	748	98		DU-56	137			DU-96	172			DU-108	194	
749 DARK	748	04		DU-113	139			DU-107	173			DU-109	195	
749 S	748	03		DU-113	139			DU-107	173			DU-109	195	
749	749	03	06											
749 BIPOSTO	749	98												
749 DARK	749	04	06											
749 R	749	03		DU-114	139			DU-110	174			DU-109	195	
749 R	749	03	06											
749 S	749	03	06											
750 ENDURANCE	750	87												
750 F1 DESMO	750	86												
750 LAGUNA SECA	750	87												
750 PASO	750	87												
750 SPORT	750	88												
750 SPORT	750													
750 SS	750	76												
INDIANA	750	88		DU-45	137			DU-50	171					
LAGUNA SECA	750	87		DU-45	137			DU-50	171					
M 750 MONSTER	750	96	97	DU-89	138			DU-90	172					
M 750 MONSTER	750	98	99	DU-105	138			DU-104	173					
M 750 MONSTER	750	99	01	DU-105	138			DU-104	173					
PASO	750	86		DU-79	137			DU-81	171					
PASO	750	89		DU-79	137			DU-81	171					
SANTA MONICA	750	88		DU-45	137			DU-50	171					
SPORT	750	00												
SS 750	750	91	97	DU-89	138			DU-90	172					
SS 750	750	98	99	DU-105	138			DU-104	173					
SS 750	750	00		DU-105	138			DU-104	173					
SS 750 SUPERSPORT	750	00												
796 HYPERMOTARD	796	10		DU-111	138			DU-112	174					
796 MONSTER	796	13		DU-111	138			DU-112	174					
SCRAMBLER	800	14		DU-126	140			DU-127	176					
SCRAMBLER CLASSIC	800	15												
SCRAMBLER ENDURO	800	15												
SRAMBLER ICON	800	15												
SPORT	802	03		DU-105	138			DU-104	173					
M 800 MONSTER DARK	803	03		DU-105	138			DU-112	174					
M 800 MONSTER S I.E.	803	03		DU-111	138			DU-112	174					
S2 R	803	05		DU-111	138			DU-112	174					
S2 R DARK	803	05		DU-111	138			DU-112	174					
SS	803	03		DU-105	138			DU-104	173					
HYPERMOTARD	821	13		DU-124	139			DU-125	175					
HYPERMOTARD SP	821	13		DU-124	139			DU-125	175					
HYPERSTRADA	821	13		DU-124	139			DU-125	175					
MONSTER	821	14		DU-124	139			DU-125	175					
MONSTER	821	15												
MONSTER DARK	821	14		DU-124	139			DU-125	175					
MONSTER DARK	821	15												
848	848	08	10											
848 EVO	848	11												
851 SP	851	91		DU-74	137			DU-97	172			DU-108	194	

FRENI - BRAKES

VALVOLE - REEDS

COLLETTORI INTAKE MANIFOLDS

FERMACOPERTONI TIRE LOCKS

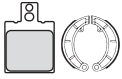

Pastiglie/Ganasce Anteriori
Front Brake Pads/Shoes

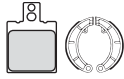

Pastiglie/Ganasce Posteriori
Rear Brake Pads/Shoes



Dischi Freno Anteriore
Front Brake Disk



Dischi Freno Posteriori
Rear Brake Disk



Lamelle
Reeds



Valvole Lamellari
Reed Valve



Valvola Power Reed
Power Reed Valve



Collettori Aspirazione
Intake Manifolds



Fermacopertoni Anteriore
Front Tire Locks



Fermacopertoni Posteriori
Rear Tire Locks

COD	PAG	COD	PAG	COD	PAG	COD	PAG	COD	PAG	COD	PAG	COD	PAG	COD	PAG	COD	PAG	COD	PAG
P.168	236	P.186	244																
P.067	214	P.012	208																
P.067	214	P.012	208																
P.168	236	P.012	208																
P.211	256	P.186	244																
P.067	214	P.012	208																
P.168	236																		
P.211	256	P.186	244																
P.168	236	P.012	208																
P.211	256	P.186	244																
P.211	256	P.186	244																
P.211	256	P.186	244																
P.211	256	P.186	244																
P.245	270	P.245	270																
P.245	270	P.245	270																
P.245	270	P.245	270																
P.245	270	P.245	270																
P.245	270	P.245	270																
P.067	214	P.012	208																
P.067	214	P.012	208																
P.067	214	P.012	208																
P.168	236	P.012	208																
P.168	236	P.186	244																
P.168	236	P.012	208																
P.168	236	P.186	244																
P.168	236	P.186	244																
P.233	264																		
P.233	264																		
P.233	264																		
P.168	236	P.012	208																
P.168	236	P.186	244																
P.168	236	P.186	244																
P.192	247	P.186	244																
P.192	247	P.186	244																
P.168	236	P.012	208																
P.233	264	P.186	244																
P.233	264	P.186	244																
P.233	264	P.186	244																
P.233	264																		
P.233	264																		
P.168	236	P.186	244																
P.229	262	P.186	244																
P.067	214	P.012	208																

MARCA - MODELLO MAKE - MODEL



Serie
Dischi Rivestiti
Friction Plate Kit



RACING
Serie
Dischi Rivestiti
Friction Plate Kit



Serie Completa
Dischi Frizione
Clutch Plates
Complete Set



RACING
Serie Completa
Dischi Frizione
Clutch Plates
Complete Set



Frizione
Antisaltellamento
Slipper Clutches



Carter Frizione
Clutch Covers

DUCATI	CC	MY	COD	PAG	COD	PAG	COD	PAG	COD	PAG	COD	PAG	COD	PAG
851 STRADA	851	89	DU-74	137			DU-97	172			DU-108	194		
888 CORSA	888	91	DU-74	137			DU-97	172			DU-108	194		
888 DESMO 4	888	93 94	DU-74	137			DU-97	172			DU-108	194		
888 SPS	888	90 93	DU-74	137			DU-97	172			DU-108	194		
888 STRADA	888	94	DU-74	137			DU-97	172			DU-108	194		
888 SUPERBIKE	888	94 95	DU-74	137			DU-97	172			DU-108	194		
899 PANIGALE	899	14												
900 SUPERLIGHT	900	92 96	DU-56	137			DU-96	172			DU-108	194		
MH 900 (V3)	900	00												
SL 900	900	92												
SSR	900	92												
M 900 MONSTER	904	93 99	DU-56	137			DU-96	172			DU-108	194		
M 900 MONSTER	904	00	DU-56	137			DU-96	172			DU-108	194		
M 900 MONSTER	904	01	DU-56	137			DU-96	172			DU-108	194		
SS 900	904	91 97	DU-56	137			DU-96	172			DU-108	194		
SS 900	904	98 00	DU-56	137			DU-96	172			DU-108	194		
SS 900	904	01	DU-113	139			DU-107	173			DU-109	195		
906 PASO	906	89												
PASO	906	89	DU-79	137			DU-81	171			DU-108	194		
907 I.E.	907	91	DU-56	137			DU-96	172			DU-108	194		
916 SP	916	94 97	DU-56	137			DU-96	172			DU-108	194		
916 SPS	916	98	DU-74	137			DU-97	172			DU-108	194		
916 STRADA	916	94 98	DU-56	137			DU-96	172			DU-108	194		
MONSTER S4	916	01	DU-113	139			DU-107	173			DU-109	195		
ST 4	916	99 00	DU-56	137			DU-96	172			DU-108	194		
ST 4	916	01 04	DU-113	139			DU-107	173						
ST 4	916	01									DU-109	195		
ST 2	944	97 00	DU-56	137			DU-96	172			DU-108	194		
ST 2	944	01	DU-113	139			DU-107	173			DU-109	195		
DESMOSEDICI (DD16RR)	990	08												
GT 1000 SPORT	992	06									DU-109	195		
PAUL SMART LIMITED	992	06	DU-113	139			DU-107	173			DU-109	195		
S2R	992	06	DU-113	139			DU-107	173						
SPORT CLASSIC	992	06	DU-113	139			DU-107	173			DU-109	195		
ST 3	992	05									DU-109	195		
ST 3	992	05 06	DU-113	139			DU-107	173						
996 BIPOSTO	996	98 00	DU-56	137			DU-96	172			DU-108	194		
996 BIPOSTO	996	01	DU-113	139			DU-107	173			DU-109	195		
996 R	996	01												
996 R	996	99 01	DU-74	137			DU-97	172			DU-108	194		
996 S	996	99 01	DU-113	139			DU-107	173			DU-109	195		
996 SPS	996	98 00	DU-74	137			DU-97	172			DU-108	194		
996 SPS	996	01	DU-113	139			DU-107	173			DU-109	195		
S4 R	996	05									DU-108	194		
S4 R MONSTER	996	05 07	DU-113	139			DU-107	173						
ST 4S	996	01 04	DU-113	139			DU-107	173						
ST 4S	996	01									DU-109	195		
ST 4S-ABS	996	03									DU-109	195		
ST 4S-ABS	996	03 04	DU-113	139			DU-107	173						
998	998	02	DU-113	139			DU-107	173			DU-109	195		
998 MATRIX	998	04	DU-113	139			DU-107	173			DU-109	195		
998 R	998	02	DU-74	137			DU-97	172			DU-108	194		
998 S	998	02	DU-113	139			DU-107	173			DU-109	195		
998 S	998	02 06												
S4 RS MONSTER	998	05												
999	999	03	DU-113	139			DU-107	173			DU-109	195		
999	999	03 06												
999 R	999	03	DU-74	137			DU-97	172			DU-108	194		
999 R	999	03 06												
999 S	999	03	DU-113	139			DU-107	173			DU-109	195		

FRENI - BRAKES

VALVOLE - REEDS

COLLETTORI INTAKE MANIFOLDS

FERMACOPERTONI TIRE LOCKS

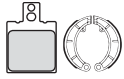

Pastiglie/Ganasce Anteriori
Front Brake Pads/Shoes

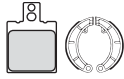

Pastiglie/Ganasce Posteriori
Rear Brake Pads/Shoes



Dischi Freno Anteriore
Front Brake Disk



Dischi Freno Posteriori
Rear Brake Disk



Lamelle
Reeds



Valvole Lamellari
Reed Valve



Valvola Power Reed
Power Reed Valve



Collettori Aspirazione
Intake Manifolds



Fermacopertoni Anteriore
Front Tire Locks



Fermacopertoni Posteriori
Rear Tire Locks

COD	PAG	COD	PAG	COD	PAG	COD	PAG	COD	PAG	COD	PAG	COD	PAG	COD	PAG	COD	PAG	COD	PAG
P.085	219	P.012	208																
P.067	214	P.012	208																
P.067	214	P.012	208																
		P.012	208																
P.067	214																		
P.233	264																		
P.067	214	P.012	208																
P.168	236	P.012	208																
P.067	214	P.012	208																
P.067	214																		
P.067	214	P.012	208																
P.168	236	P.186	244																
P.168	236	P.186	244																
P.067	214	P.012	208																
P.168	236	P.186	244																
P.168	236	P.186	244																
P.245	270	P.245	270																
P.067	214	P.012	208																
P.067	214	P.012	208																
P.168	236	P.186	244																
P.067	214	P.012	208																
P.168	236	P.186	244																
P.168	236	P.186	244																
P.168	236	P.186	244																
P.067	214	P.186	244																
P.168	236	P.186	244																
P.229	262	P.186	244																
P.192	247	P.172	238																
P.192	247	P.172	238																
P.192	247	P.172	238																
P.168	236	P.186	244																
P.168	236																		
P.168	236	P.012	208																
P.211	256	P.012	208																
P.168	236	P.012	208																
P.168	236	P.012	208																
P.168	236	P.012	208																
P.168	236	P.186	244																
P.168	236	P.186	244																
P.168	236	P.012	208																
P.211	256	P.186	244																
P.211	256	P.012	208																
P.211	256	P.012	208																
P.211	256	P.186	244																
P.211	256	P.186	244																

MARCA - MODELLO MAKE - MODEL



Serie
Dischi Rivestiti
Friction Plate Kit



RACING
Serie
Dischi Rivestiti
Friction Plate Kit



Serie Completa
Dischi Frizione
Clutch Plates
Complete Set



RACING
Serie Completa
Dischi Frizione
Clutch Plates
Complete Set



Frizione
Antisaltellamento
Slipper Clutches



Carter Frizione
Clutch Covers

DUCATI	CC	MY	COD	PAG	COD	PAG	COD	PAG	COD	PAG	COD	PAG	COD	PAG
999 S	999	03	04											
1000 MILLE REPLICA	1000	05												
1000 S2 DESMO	1000	85												
1000 all models	1000	84												
1000 HF I.E.	1000	03		DU-113 139				DU-107 173					DU-109 195	
1000 MULTISTRADA DS	1000	03		DU-113 139				DU-107 173					DU-109 195	
1000 SS I.E.	1000	03		DU-113 139				DU-107 173					DU-109 195	
MONSTER DARK I.E.	1000	03		DU-113 139				DU-107 173					DU-109 195	
MONSTER S I.E.	1000	03		DU-113 139				DU-107 173					DU-109 195	
MONSTER S2R	1000	06												
S2 R MONSTER	1000	06		DU-113 139				DU-107 173						
SPORT	1000	06												
HYPERMOTARD	1078	07	09	DU-116 139				DU-117 174					DU-109 195	
HYPERMOTARD	1078	10		DU-116 139				DU-119 175					DU-120 195	
HYPERMOTARD S	1078	07	09	DU-116 139				DU-118 175					DU-109 195	
HYPERMOTARD S	1078	10		DU-116 139				DU-119 175					DU-120 195	
MULTISTRADA	1078	07											DU-109 195	
MULTISTRADA S	1078	07											DU-109 195	
1098	1099	07	08	DU-116 139				DU-117 174					DU-115 195	
1098	1099	09		DU-116 139				DU-119 175					DU-120 195	
1098 R	1099	07		DU-116 139				DU-118 175						
1098 R	1099	08	09											
1098 S	1099	07	08	DU-116 139				DU-117 174						
1098 S	1099	09											DU-120 195	
1098 S	1099	09		DU-116 139				DU-119 175						
1098 TRICOLORE	1099	07		DU-116 139				DU-117 174					DU-120 195	
STREETFIGHTER	1099	09												
STREETFIGHTER	1099	10		DU-116 139				DU-119 175						
STREETFIGHTER S	1099	09												
1198	1100	09												
1198 S	1100	09												
HYPERMOTARD	1100	07	09											
HYPERMOTARD EVO	1100	10												
HYPERMOTARD S	1100	07	09											
HYPERMOTARD EVO SP	1100	10												
MONSTER	1100	09												
MONSTER EVO	1100	11												
MONSTER S	1100	09												
MULTISTRADA	1100	07	09											
MULTISTRADA S	1100	07	09											
1198	1198	09											DU-120 195	
1198 S	1198	09		DU-116 139				DU-119 175					DU-120 195	
1198	1199	09		DU-116 139				DU-119 175						
PANIGALE	1199	12												
PANIGALE S	1199	12												
DIAVEL	1200	11												
MONSTER 1200	1200	14												
MULTISTRADA	1200	10												
MULTISTRADA 1200	1200	15												
ETON	CC	MY												
RXL 50 VIPER	50	03												
RXL 70 VIPER	70	03												
RXL 90 VIPER	90	03												
RXL 150 VIPER	150	07												
ST EXL 150 VIPER	150	05												
VXL 250 VECTOR ST VECTOR	250	06												
VTL 300 VORTEX ST VORTEX	300	07												
VXL 300 VECTOR ST VECTOR	300	07												
FACTORY	CC	MY												
100 HELIX	100	04												

FRENI - BRAKES

VALVOLE - REEDS

COLLETTORI INTAKE MANIFOLDS

FERMACOPERTONI TIRE LOCKS

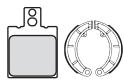

Pastiglie/Ganasce Anteriore
Front Brake Pads/Shoes

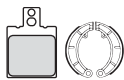

Pastiglie/Ganasce Posteriori
Rear Brake Pads/Shoes



Dischi Freno Anteriore
Front Brake Disk



Dischi Freno Posteriori
Rear Brake Disk



Lamelle
Reeds



Valvole Lamellari
Reed Valve



Valvola Power Reed
Power Reed Valve



Collettori Aspirazione
Intake Manifolds



Fermacopertoni Anteriore
Front Tire Locks



Fermacopertoni Posteriori
Rear Tire Locks

COD	PAG	COD	PAG	COD	PAG	COD	PAG	COD	PAG	COD	PAG	COD	PAG	COD	PAG	COD	PAG	COD	PAG
P.211	256	P.186	244																
P.245	270	P.245	270																
P.245	270	P.245	270																
P.245	270	P.245	270																
P.168	236	P.186	244																
P.168	236	P.186	244																
P.168	236	P.186	244																
P.168	236	P.012	208																
P.168	236																		
P.168	236	P.186	244																
P.192	247	P.172	238																
P.229	262	P.186	244																
P.229	262	P.186	244																
P.229	262	P.186	244																
		P.186	244																
P.229	262	P.186	244																
P.229	262	P.186	244																
P.229	262	P.186	244																
P.229	262	P.186	244																
P.229	262	P.186	244																
P.229	262	P.186	244																
P.229	262	P.186	244																
P.229	262	P.186	244																
P.168	236	P.186	244																
P.168	236	P.186	244																
P.168	236	P.186	244																
P.168	236	P.186	244																
P.168	236	P.186	244																
		P.186	244																
P.229	262	P.186	244																
P.229	262	P.143	230																
P.233	264																		
P.168	236	P.186	244																
P.233	264																		
		P.260	277																
		P.260	277																
		P.260	277																
		P.263	279																
P.260	277																		
P.260	277	P.263	279																
P.260	277	P.263	279																
P.260	277	P.263	279																
		P.260	277																

MARCA - MODELLO MAKE - MODEL



Serie
Dischi Rivestiti
Friction Plate Kit



RACING
Serie
Dischi Rivestiti
Friction Plate Kit



Serie Completa
Dischi Frizione
Clutch Plates
Complete Set



RACING
Serie Completa
Dischi Frizione
Clutch Plates
Complete Set



Frizione
Antisaltemento
Slipper Clutches



Carter Frizione
Clutch Covers

FACTORY	CC	MY	COD	PAG	COD	PAG	COD	PAG	COD	PAG	COD	PAG	COD	PAG
100 REX	100	04												
FACTORY ATV	CC	MY												
HELIX 50	50	04												
REX 50	50	04												
HELIX 100	100	04												
FANTIC	CC	MY												
BIG WHEELS	50	91												
BIP RACING	50	94												
CABALLERO RC	50	94												
CABALLERO RC-RS	50	92												
CICLONE	50	94												
CLUBMAN	50	95												
GRINTA	50	97												
K ROO	50	92												
KET ROO	50	93												
KOALA	50	88												
OASIS RALLY	50	86												
PONY SR	50	92												
QUEENIE	50	95												
TRIAL	50	92												
TRIAL H20	50	87												
CABALLERO RC	80	94												
K ROO	80	92												
TRIAL	80	92												
CABALLERO RC	125	94												
K ROO	125	92												
PROFESSIONAL (FM 361)	125	87												
TRIAL 125.1-125.2	125	87												
TRIAL 125.5	125	89								FM-54/C	179			
TRIAL 125.7	125	90								FM-54/C	179			
TRIAL 125.9	125	90								FM-54/C	179			
TRIAL	201	86												
TRIAL (FM 363)	243	87												
TRIAL	247	90								FM-54/C	179			
SECTION	249	95												
TRIAL COACH	249	89												
COACH	250	92	94											
COACH	250	95												
RAIDER (FM 259)	250	85												
TRIAL 301.1	301	86												
TRIAL (FM 364)	303	87												
TRIAL 303.2	303	87												
TRIAL	305	89								FM-54/C	179			
TRIAL	307	90								FM-54/C	179			
K ROO	309	91								FM-54/C	179			
GARELLI	CC	MY												
CICLONE LC	50	86						GA-70	179					
FORMUNO RAID	50	89												
SUPER CICLONE LC	50	91						GA-70	179					
TIGER XLE	50	86						GA-70	179					
URKA AC-LC	50	89						GA-70	179					
SAHEL	80	89						GA-70	179					
HAWR	125	86												
RAIDER 125	125	02												
TIGER XLE	125	87												
TIGER XR-XRD	125	86												
TRIAL SECTION	125	95												
HAWR	200	86												
TRIAL SECTION	249	95												
TRIAL	323	86												

FRENI - BRAKES

VALVOLE - REEDS

COLLETTORI INTAKE MANIFOLDS

FERMACOPERTONI TIRE LOCKS

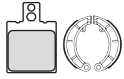

Pastiglie/Ganasce Anteriore
Front Brake Pads/Shoes

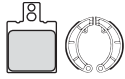

Pastiglie/Ganasce Posteriori
Rear Brake Pads/Shoes



Dischi Freno Anteriore
Front Brake Disk



Dischi Freno Posteriori
Rear Brake Disk



Lamelle
Reeds



Valvole Lamellari
Reed Valve



Valvola Power Reed
Power Reed Valve



Collettori Aspirazione
Intake Manifolds



Fermacopertoni Anteriore
Front Tire Locks



Fermacopertoni Posteriori
Rear Tire Locks

COD	PAG	COD	PAG	COD	PAG	COD	PAG	COD	PAG	COD	PAG	COD	PAG	COD	PAG	COD	PAG	COD	PAG
		P.260	277																
		P.260	277																
		P.260	277																
		P.260	277																
P.141	229			DF-12	297			77	314					FB-134	327				
				DF-12	297			77	314					FB-134	327				
P.158	233																		
P.012	208							29	312										
P.071	215																		
P.065	213	P.065	213																
P.141	229			DF-12	297			77	314					FB-134	327				
P.065	213	P.065	213																
P.065	213	P.065	213					29	312										
P.098	222																		
P.141	229	01205	288	DF-12	297			77	314					FB-134	327				
P.141	229	01205	288	DF-12	297			77	314					FB-134	327				
P.075	217																		
P.071	215																		
P.074	216							29	312										
P.065	213	P.065	213																
P.065	213	P.065	213																
P.074	216																		
P.065	213	P.065	213																
P.071	215	P.071	215																
P.065	213	P.065	213																
P.065	213	P.065	213																
P.065	213	P.065	213																
P.065	213	P.065	213																
P.071	215																		
P.071	215	P.071	215																
P.065	213	P.065	213																
P.065	213	P.065	213																
P.065	213	P.065	213																
P.065	213	P.065	213																
P.065	213	P.065	213																
P.065	213	P.065	213																
P.065	213	P.065	213																
P.065	213	P.065	213																
P.065	213	P.065	213					10	310					FM-57	328				
P.065	213	P.065	213					10	310					FM-57	328				
P.065	213	P.065	213					10	310					FM-57	328				
P.071	215							23	312										
								27	312										
P.071	215																		
P.012	208							23	312										
P.071	215																		
P.098	222	P.065	213					23	312										
P.074	216																		
P.260	277																		
P.074	216																		
P.012	208																		
P.065	213	P.065	213																
P.074	216																		
P.065	213	P.065	213																
P.065	213																		

MARCA - MODELLO MAKE - MODEL



Serie
Dischi Rivestiti
Friction Plate Kit



RACING
Serie
Dischi Rivestiti
Friction Plate Kit



Serie Completa
Dischi Frizione
Clutch Plates
Complete Set



RACING
Serie Completa
Dischi Frizione
Clutch Plates
Complete Set



Frizione
Antisaltellamento
Slipper Clutches



Carter Frizione
Clutch Covers

GAS GAS	CC	MY	COD	PAG	COD	PAG	COD	PAG	COD	PAG	COD	PAG	COD	PAG
CROSS MC	50	06												
EC BOY	50	01	04											
EC BOY	50	05												
EC BOY L.C.	50	05												
EC ROOKIE	50	01	04											
SM	50	05												
SM ROOKIE	50	01	04											
TXT BOY	50	01	03											
TXT BOY	50	04												
TXT ROOKIE	50	03												
MC	65	05												
TXT ROOKIE	80	04	05											
EC (BREMBO)	125	97	99											
EC (NISSIN)	125	00	07											
MC	125	05												
MX	125	01	04											
PAMPERA	125	96	02											
PAMPERA	125	03	04											
PAMPERA	125	05												
SM	125	02												
TXT	125	00	03											
TXT PRO	125	02						GS-1	181					
TXT PRO	125	04												
EC (BREMBO)	200	97	99											
EC (NISSIN)	200	00	07											
EC 2T	200	07		GS-4	144			GS-5	181					
EC HOBBY 2T	200	07	08	GS-4	144			GS-5	181					
JTX	200	95	98											
TXT	200	00	03											
TXT PRO	200	02						GS-1	181					
TXT PRO	200	04												
CONTACT T 25	250	93												
CROSS	250	95												
EC (BREMBO)	250	97	99											
EC (NISSIN)	250	00	07											
EC 2T	250	07		GS-4	144			GS-5	181					
FSE 4T	250	99												
JT 25	250	91												
JT CONTACT	250	94												
JTR CONTACT	250	96												
MC	250	99												
MC	250	00												
MX	250	01	04											
PAMPERA	250	03												
SM	250	01												
TT	250	95												
TXT	250	00	03											
TXT PRO	250	02						GS-1	181					
TXT PRO	250	04												
JTX	270	95	98											
TX	270	98												
TXT	270	98												
TXT	270	99	00											
PAMPERA	280	04												
TXT	280	00	03											
TXT BOY	280	01												
TXT PRO	280	02						GS-1	181					
TXT PRO	280	04												
EC (BREMBO)	300	97	99											
EC (NISSIN)	300	00	07											

FRENI - BRAKES

VALVOLE - REEDS

COLLETTORI INTAKE MANIFOLDS

FERMACOPERTONI TIRE LOCKS

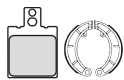

Pastiglie/Ganasce Anteriore
Front Brake Pads/Shoes

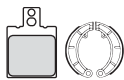

Pastiglie/Ganasce Posteriori
Rear Brake Pads/Shoes



Dischi Freno Anteriore
Front Brake Disk



Dischi Freno Posteriori
Rear Brake Disk



Lamelle
Reeds



Valvole Lamellari
Reed Valve



Valvola Power Reed
Power Reed Valve



Collettori Aspirazione
Intake Manifolds



Fermacopertoni Anteriore
Front Tire Locks



Fermacopertoni Posteriori
Rear Tire Locks

COD	PAG	COD	PAG	COD	PAG	COD	PAG	COD	PAG	COD	PAG	COD	PAG	COD	PAG	COD	PAG	COD	PAG
P.198	249	P.200	250																
P.198	249	P.198	249																
P.065	213	P.200	250																
P.199	250	P.200	250																
P.133	227	P.198	249																
P.158	233	P.198	249																
P.133	227	P.198	249																
P.198	249	P.198	249																
P.065	213	P.065	213																
P.198	249	P.198	249																
P.200	250	P.065	213																
P.199	250	P.200	250																
P.143	230	P.172	238																
P.190	246	P.093	221																
P.190	246	P.093	221																
P.190	246	P.093	221																
P.065	213	P.065	213																
P.158	233	P.198	249																
P.158	233	P.093	221																
P.067	214	P.093	221																
P.198	249	P.198	249																
P.199	250	P.200	250																
P.143	230	P.172	238																
P.190	246	P.093	221																
P.065	213	P.065	213																
P.198	249	P.198	249																
P.199	250	P.200	250																
P.065	213	P.065	213																
P.143	230	P.075	217																
P.143	230	P.172	238																
P.190	246	P.093	221																
P.143	230	P.172	238																
P.065	213	P.065	213																
P.065	213	P.065	213																
P.065	213	P.065	213																
P.143	230	P.172	238																
P.190	246	P.093	221																
P.190	246	P.093	221																
P.158	233	P.065	213																
P.107	224	P.093	221																
P.143	230	P.172	238																
P.198	249	P.198	249																
P.199	250	P.200	250																
P.065	213	P.065	213																
P.065	213	P.065	213																
P.065	213	P.065	213																
P.198	249	P.198	249																
P.158	233	P.198	249																
P.198	249	P.198	249																
P.198	249	P.198	249																
P.199	250	P.200	250																
P.143	230	P.172	238																
P.190	246	P.093	221																

MARCA - MODELLO MAKE - MODEL



Serie
Dischi Rivestiti
Friction Plate Kit



RACING
Serie
Dischi Rivestiti
Friction Plate Kit



Serie Completa
Dischi Frizione
Clutch Plates
Complete Set



RACING
Serie Completa
Dischi Frizione
Clutch Plates
Complete Set



Frizione
Antisaltemento
Slipper Clutches



Carter Frizione
Clutch Covers

GAS GAS	CC	MY	COD	PAG	COD	PAG	COD	PAG	COD	PAG	COD	PAG	COD	PAG
EC 2T	300	07	GS-4	144			GS-5	181						
EC SIX DAYS 2T	300	09	GS-4	144			GS-5	181						
TXT PRO	300	02					GS-1	181						
TXT PRO	300	04												
JT 32	320	91												
PAMPERA	320	98	99											
TXT	321	00	03											
HALLEY PCX	325	87												
TRIAL	327	89												
JTR CONTACT	370	96												
EC FSE	400	01												
FSE 4T	400	99												
PAMPERA	400	06												
SM FSE	400	01	02											
EC 4T	450	09	GS-4	144			GS-5	181						
FSE	450	05	06								GS-2	196		
FSR	450	07									GS-2	196		
FSR 4T	450	07	GS-4	144			GS-5	181						
SM	450	03	06											
FSE	500	05	06											
EC 4T	515	09	GS-4	144			GS-5	181						
FSR	515	08									GS-2	196		
FSR 4T	515	08	GS-4	144			GS-5	181						
GENERIC	CC	MY												
ZION 125	125	08												
GILERA	CC	MY												
503	50	92	GI-130	144										
BULLIT	50	90	GI-130	144										
DNA L.C. (G)	50	00	02											
DNA L.C. (H)	50	00												
EASY MOVING	50	96												
GP	50	03												
GPR POGGIALI REPLICA	50	03												
GSM	50	00												
ICE	50	01												
NRG	50	93												
NRG	50	96												
NRG-MC2	50	99	00											
NRG-MC3	50	01												
NTT	50	94												
NTT	50	96												
RALLY	50	90	GI-130	144										
RUNNER	50	97												
RUNNER DD	50	97												
RUNNER SP	50	01	04											
RUNNER SP	50	05												
STALKER DD	50	99												
STALKER DT	50	99												
STORM	50	94												
TYPHOON	50	96	00											
TYPHOON X	50	01												
A-E ARIZONA RZE	125	87	GI-102	143			GI-105	179						
APACHE	125	92	GI-128	143			GI-129	180						
CCM APTS	125	87	GI-102	143			GI-105	179						
CRONO AE	125	91	GI-128	143			GI-129	180						
CX-AE	125	91	GI-128	143			GI-129	180						
DNA 4T (G)	125	01	02											
DNA 4T (H)	125	01	03											
ER	125	87	GI-102	143			GI-105	179						
FAST BIKE	125	87	GI-102	143			GI-105	179						

FRENI - BRAKES

VALVOLE - REEDS

COLLETTORI INTAKE MANIFOLDS

FERMACOPERTONI TIRE LOCKS

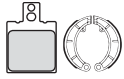

Pastiglie/Ganasce Anteriore
Front Brake Pads/Shoes

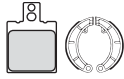

Pastiglie/Ganasce Posteriori
Rear Brake Pads/Shoes



Dischi Freno Anteriore
Front Brake Disk



Dischi Freno Posteriori
Rear Brake Disk



Lamelle
Reeds



Valvole Lamellari
Reed Valve



Valvola Power Reed
Power Reed Valve



Collettori Aspirazione
Intake Manifolds



Fermacopertoni Anteriore
Front Tire Locks



Fermacopertoni Posteriori
Rear Tire Locks

COD	PAG	COD	PAG	COD	PAG	COD	PAG	COD	PAG	COD	PAG	COD	PAG	COD	PAG	COD	PAG	COD	PAG
P.199	250	P.200	250																
P.065	213	P.065	213																
P.065	213	P.065	213																
P.198	249	P.198	249																
P.071	215	P.071	215																
P.065	213	P.065	213																
P.065	213	P.065	213																
P.190	246	P.093	221																
P.143	230	P.172	238																
P.143	230	P.093	221																
P.067	214	P.093	221																
P.190	246	P.093	221																
P.067	214	P.093	221																
P.067	214																		
P.190	246	P.093	221																
P.067	214	P.093	221																
P.259	277																		
P.071	215	P.071	215					29	312										
P.071	215							29	312										
P.158	233	P.193	247	DF-23	300	DF-10	296												
P.204	253	P.193	247	DF-23	300	DF-10	296												
P.139	228	0266	286	DF-12	297			83	314					VE-371	329				
		P.065	213																
P.133	227																		
P.065	213	P.065	213																
P.139	228	01284	289					83	314					VE-371	329				
P.139	228	0266	286	DF-1	292			83	314					VE-371	329				
P.139	228	0275	286	DF-1	292			83	314					VE-371	329				
P.139	228	P.175	240	DF-1	292	DF-16	298	83	314					VE-371	329				
P.139	228	P.175	240					83	314					VE-371	329				
P.139	228			DF-1	292			83	314					VE-371	329				
P.139	228	0275	286	DF-1	292			83	314					VE-371	329				
P.012	208							29	312										
P.175	240	01284	289	DF-19	299			83	314					VE-371	329				
P.139	228	P.175	240			DF-16	298	83	314					VE-371	329				
P.175	240	P.175	240	DF-19	299	DF-16	298	83	314					VE-371	329				
		P.175	240			DF-16	298							VE-371	329				
P.139	228	P.175	240	DF-1	292	DF-16	298	83	314					VE-371	329				
P.139	228	P.175	240					83	314					VE-371	329				
P.139	228	0266	286																
P.175	240	0266	286	DF-1	292			83	314					VE-371	329				
P.175	240	0266	286	DF-1	292			83	314					VE-371	329				
P.074	216							12	310										
		P.079	218					12	310				PWR-1	322					
P.074	216	P.012	208					12	310				PWR-1	322					
P.085	219	P.012	208					12	310				PWR-1	322					
P.085	219	P.012	208					12	310				PWR-1	322					
P.158	233	P.193	247	DF-23	300	DF-23	300												
P.204	253	P.193	247	DF-23	300	DF-23	300												
P.074	216							12	310					PWR-1	322				
P.074	216	P.012	208					12	310					PWR-1	322				

MARCA - MODELLO MAKE - MODEL



Serie
Dischi Rivestiti
Friction Plate Kit



RACING
Serie
Dischi Rivestiti
Friction Plate Kit



Serie Completa
Dischi Frizione
Clutch Plates
Complete Set



RACING
Serie Completa
Dischi Frizione
Clutch Plates
Complete Set



Frizione
Antisaltemento
Slipper Clutches



Carter Frizione
Clutch Covers

GILERA	CC	MY	COD	PAG	COD	PAG	COD	PAG	COD	PAG	COD	PAG	COD	PAG
FREESTYLE	125	92	GI-128	143			GI-129	180						
GFR	125	93	GI-128	143			GI-129	180						
HX LC	125	83												
KZ	125	86	GI-102	143			GI-105	179						
KZ ENDURANCE	125	88	GI-102	143			GI-105	179						
MX 1	125	88	GI-102	143			GI-105	179						
MXR	125	89	GI-102	143			GI-105	179						
NEXUS	125	07												
R 1	125	88	GI-102	143			GI-105	179						
RC	125	90	GI-128	143			GI-129	180						
RC RALLY	125	88	GI-102	143			GI-105	179						
RC TOP RALLY	125	90	GI-128	143			GI-129	180						
RRT NEBRASKA	125	87	GI-102	143			GI-105	179						
RTX	125	86	GI-102	143			GI-105	179						
RUNNER FX (G)	125	97	99											
RUNNER FX (G)	125	00												
RUNNER FX (H)	125	97	99											
RUNNER FX (H)	125	00												
RUNNER SP	125	98	00											
RUNNER SP	125	01												
RUNNER VX (G)	125	01												
RUNNER VX (H)	125	01												
RV	125	84	GI-102	143			GI-105	179						
RV ES	125	87	GI-102	143			GI-105	179						
RVE A-E	125	87	GI-102	143			GI-105	179						
RX ARIZONA	125	83	GI-102	143			GI-105	179						
SATURNO PIUMA	125	90	GI-128	143			GI-129	180						
SP 01	125	89	GI-128	143			GI-129	180						
SP 02	125	90	GI-128	143			GI-129	180						
TX 1	125	88	GI-102	143			GI-105	179						
TYPHOON	125	96												
X 1	125	89	GI-102	143			GI-105	179						
XR 1	125	88	GI-102	143			GI-105	179						
XR 2	125	89	GI-102	143			GI-105	179						
DNA 4T (G)	180	01												
DNA 4T (H)	180	01												
RUNNER FXR (G)	180	00												
RUNNER FXR (H)	180	00												
RUNNER FXR SP (G)	180	99												
RUNNER FXR SP (H)	180	99												
RUNNER VXR 4T (G)	180	01												
RUNNER VXR 4T (H)	180	01												
ARIZONA	200	83	GI-102	143			GI-105	179						
ER	200	87	GI-102	143			GI-105	179						
FAST BIKE	200	87	GI-102	143			GI-105	179						
RTX	200	86	GI-102	143			GI-105	179						
RUNNER FX	200	97	98											
RUNNER SP	200	99												
RV A-E	200	87	GI-102	143			GI-105	179						
RV ES	200	87	GI-102	143			GI-105	179						
RX	200	83	GI-102	143			GI-105	179						
AR ARIZONA RALLY	250	86	GI-81	143										
HX LC	250	83	GI-81	143										
N R G	250	87	GI-81	143										
NE	250	83	GI-81	143										
NEXUS I.E.	250	06												
NX	250	83	GI-81	143										
RAIDER	250	86	GI-81	143										
RALLY	250	86	GI-81	143										
TRIAL	323	86												

FRENI - BRAKES

VALVOLE - REEDS

COLLETTORI INTAKE MANIFOLDS

FERMACOPERTONI TIRE LOCKS

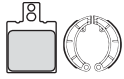

Pastiglie/Ganasce Anteriori
Front Brake Pads/Shoes

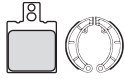

Pastiglie/Ganasce Posteriori
Rear Brake Pads/Shoes



Dischi Freno Anteriore
Front Brake Disk



Dischi Freno Posteriori
Rear Brake Disk



Lamelle
Reeds



Valvole Lamellari
Reed Valve



Valvola Power Reed
Power Reed Valve



Collettori Aspirazione
Intake Manifolds



Fermacopertoni Anteriore
Front Tire Locks



Fermacopertoni Posteriori
Rear Tire Locks

COD	PAG	COD	PAG	COD	PAG	COD	PAG	COD	PAG	COD	PAG	COD	PAG	COD	PAG	COD	PAG	COD	PAG
P.085	219	P.012	208					12	310			PWR-1	322						
P.085	219	P.012	208					12	310			PWR-1	322						
P.012	208																		
P.074	216	P.012	208					12	310			PWR-1	322						
P.074	216	P.012	208					12	310			PWR-1	322						
P.085	219	P.012	208					12	310			PWR-1	322						
P.085	219	P.012	208					12	310			PWR-1	322						
P.204	253	P.204	253																
P.074	216	P.012	208					12	310			PWR-1	322						
		P.012	208					12	310			PWR-1	322						
P.074	216							12	310			PWR-1	322						
		P.079	218					12	310			PWR-1	322						
P.074	216							12	310			PWR-1	322						
P.074	216							12	310			PWR-1	322						
P.158	233	01284	289	DF-19	299														
P.158	233	01284	289	DF-19	299	DF-23	300												
P.204	253	01284	289	DF-19	299														
P.204	253	01284	289	DF-19	299	DF-23	300												
P.158	233	P.175	240	DF-19	299	DF-23	300												
P.158	233	P.139	228	DF-19	299	DF-23	300												
P.158	233	P.193	247	DF-19	299	DF-10	296												
P.204	253	P.193	247			DF-10	296												
P.012	208							12	310			PWR-1	322						
								12	310			PWR-1	322						
P.074	216							12	310			PWR-1	322						
P.012	208							12	310			PWR-1	322						
P.067	214	P.065	213					12	310			PWR-1	322						
P.085	219	P.012	208					12	310			PWR-1	322						
P.085	219	P.012	208					12	310			PWR-1	322						
P.074	216							12	310			PWR-1	322						
P.139	228	01284	289	DF-1	292														
P.074	216							12	310			PWR-1	322						
P.074	216	P.012	208					12	310			PWR-1	322						
		P.012	208					12	310			PWR-1	322						
P.158	233	P.193	247	DF-23	300														
P.204	253	P.193	247	DF-23	300	DF-23	300												
P.158	233	P.175	240	DF-19	299	DF-23	300							VE-383	329				
P.204	253	0278	286	DF-19	299	DF-23	300							VE-383	329				
P.158	233	P.175	240	DF-19	299	DF-23	300							VE-383	329				
P.158	233	P.175	240	DF-19	299	DF-19	299							VE-383	329				
P.158	233	P.193	247																
P.158	233	P.193	247	DF-19	299														
P.012	208							12	310										
P.074	216							12	310										
P.074	216	P.012	208					12	310										
P.074	216	P.012	208					12	310										
P.133	227	0278	286																
P.158	233	P.175	240																
P.074	216	P.012	208					12	310										
P.074	216	P.012	208					12	310										
P.012	208							12	310										
P.012	208																		
P.012	208																		
		P.012	208																
P.012	208																		
P.204	253	P.204	253	DF-31	303	DF-30	303												
P.012	208																		
P.074	216																		
P.012	208	P.012	208																
P.065	213																		

MARCA - MODELLO MAKE - MODEL



Serie
Dischi Rivestiti
Friction Plate Kit



RACING
Serie
Dischi Rivestiti
Friction Plate Kit



Serie Completa
Dischi Frizione
Clutch Plates
Complete Set



RACING
Serie Completa
Dischi Frizione
Clutch Plates
Complete Set



Frizione
Antisaltemento
Slipper Clutches



Carter Frizione
Clutch Covers

GILERA	CC	MY	COD	PAG	COD	PAG	COD	PAG	COD	PAG	COD	PAG	COD	PAG
DAKOTA 4 T	350	86	GI-81	143			GI-108	180						
ER	350	87	GI-81	143			GI-108	180						
NORDWEST	350	94	GI-121	143			GI-123	180						
XRT	350	89	GI-81	143			GI-108	180						
DAKOTA	500	87												
ER	500	87												
FUOCO I.E.	500	07												
NEXUS	500	04												
NEXUS I.E.	500	06												
SATURNO	500	89												
SATURNO PIUMA	500	90												
NORDWEST	600	91	GI-121	143			GI-123	180						
RC	600	88	GI-121	143			GI-123	180						
RC	600	89	GI-121	143			GI-123	180						
RC 4 VALVOLE	600	91	GI-121	143			GI-123	180						
RC R	600	92	GI-121	143			GI-123	180						
RC R-COBRA	600	94	GI-121	143			GI-123	180						
SUPERSPORT	600	02												
XRT	600	88	GI-121	143			GI-123	180						
XRT	600	89	GI-121	143			GI-123	180						
GP	800	07												
HM	CC	MY												
CRE BAJA	50	01 02	FB-132	142	FB-132/M	142	FB-140	178	FB-140/C	178				
CRE BAJA	50	03 06	FB-132	142	FB-132/M	142	FB-140	178	FB-140/C	178				
CRE BAJA	50	03 09												
CRE ENDURO	50	99	FB-132	142	FB-132/M	142	FB-140	178	FB-140/C	178				
DERAPAGE	50	01 02	FB-132	142	FB-132/M	142	FB-140	178	FB-140/C	178				
DERAPAGE	50	03 06	FB-132	142	FB-132/M	142	FB-140	178	FB-140/C	178				
SIX	50	03 06	FB-132	142	FB-132/M	142	FB-140	178	FB-140/C	178				
CR MOTARD	125	04 06	HO-182	149			HO-183	183	HO-183/C	184				
CRE R ENDURO	125	02 03												
CRE R ENDURO	125	04 07	HO-182	149			HO-183	183	HO-183/C	184				
CRE R SUPERMOTARD	125	02 03	HO-182	149			HO-183	183	HO-183/C	184				
CRE	250	97 01												
CRE	250	02												
CRE F ENDURO	250	04	HO-182	149			HO-183	183	HO-183/C	184				
CRE R ENDURO	250	02 07	HO-119	147			HO-121	183						
CRE R SUPERMOTARD	250	02 03	HO-119	147			HO-121	183						
CRF MOTARD	250	04 06	HO-182	149			HO-183	183	HO-183/C	184				
CRE F ENDURO	450	02									HO-201	198	HO-203	202
CRF MOTARD	450	04									HO-192	196	HO-199	202
CRM F R SUPERMOTO	450	07									HO-192	196	HO-199	202
CRM F X SUPERMOTO	450	07									HO-192	196	HO-199	202
CRE F X	490	07									HO-201	198	HO-203	202
CRM F X SUPERMOTO	490	07									HO-192	196	HO-199	202
HONDA	CC	MY												
BALI	50	93												
DAX ST	50	93												
DIO SCOOTER	50	91												
DIO ZX	50	94												
GP DIO	50	92												
MB SA-SB	50	80 82												
MBX SD-SF-SH	50	83 87												
MT SA-SE-SG-SJ-SL	50	80 93												
MTX SD	50	83 87												
SFX	50	95												
SH FIFTY	50	00												
SH SCOOPY	50	96												
SKY	50	97												
X 8 R	50	98												

FRENI - BRAKES

VALVOLE - REEDS

COLLETTORI INTAKE MANIFOLDS

FERMACOPERTONI TIRE LOCKS

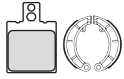

Pastiglie/Ganasce Anteriore
Front Brake Pads/Shoes

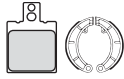

Pastiglie/Ganasce Posteriori
Rear Brake Pads/Shoes



Dischi Freno Anteriore
Front Brake Disk



Dischi Freno Posteriori
Rear Brake Disk



Lamelle
Reeds



Valvole Lamellari
Reed Valve



Valvola Power Reed
Power Reed Valve



Collettori Aspirazione
Intake Manifolds



Fermacopertoni Anteriore
Front Tire Locks



Fermacopertoni Posteriori
Rear Tire Locks

COD	PAG	COD	PAG	COD	PAG	COD	PAG	COD	PAG	COD	PAG	COD	PAG	COD	PAG	COD	PAG	COD	PAG
P.074	216																		
P.074	216																		
		P.012	208																
P.074	216	P.012	208																
P.074	216																		
P.074	216																		
P.175	240	P.212	257																
P.143	230	P.186	244	DF-31	303	DF-30	303												
P.204	253	P.204	253	DF-31	303	DF-30	303												
P.067	214	P.012	208																
		P.065	213																
P.085	219	P.012	208																
P.074	216	P.012	208																
		P.079	218																
		P.079	218																
		P.079	218																
		P.012	208																
		P.186	244																
P.074	216																		
		P.012	208																
P.143	230																		
P.143	230	P.065	213																
P.158	233	P.201	251																
P.158	233	P.075	217																
P.143	230	P.065	213																
P.158	233	P.201	251																
P.158	233	P.201	251																
P.190	246	P.202	251																
P.190	246	P.202	251																
P.190	246	P.202	251																
P.190	246	P.202	251																
P.190	246	P.093	221																
P.190	246	P.202	251																
P.190	246	P.202	251																
P.190	246	P.202	251																
P.190	246	P.202	251																
P.190	246	P.202	251																
P.190	246	P.202	251																
P.190	246	P.202	251																
P.190	246	P.202	251																
P.190	246	P.202	251																
P.190	246	P.202	251																
P.074	216			DF-5	293			83	314					VE-371	329				
								83	314					VE-371	329				
				DF-4	293			83	314					VE-371	329				
				DF-4	293			83	314					VE-371	329				
				DF-4	293			83	314					VE-371	329				
P.003	208							24	312	YA-38	321								
		01200	288					24	312	YA-38	321								
								24	312	YA-38	321								
								24	312	YA-38	321								
P.139	228							83	314					VE-371	329				
P.139	228																		
P.139	228							83	314					VE-371	329				
P.139	228			DF-5	293			83	314					VE-371	329				
P.139	228							83	314					VE-371	329				

MARCA - MODELLO MAKE - MODEL



Serie
Dischi Rivestiti
Friction Plate Kit



RACING
Serie
Dischi Rivestiti
Friction Plate Kit



Serie Completa
Dischi Frizione
Clutch Plates
Complete Set



RACING
Serie Completa
Dischi Frizione
Clutch Plates
Complete Set



Frizione
Antisaltemento
Slipper Clutches



Carter Frizione
Clutch Covers

HONDA	CC	MY	COD	PAG	COD	PAG	COD	PAG	COD	PAG	COD	PAG	COD	PAG
ZX SCOOTER	50	94												
NSR	75	90												
CR RE-F-2F-G-2G-H-T	80	84	89											
MB 80	80	80												
MBX FWD	80	83	86											
MCX 80 all models	80	82												
CR R	85	03												
TRX EX	90	07												
TRX P/R/S/T/V/W/X/Y1-6	90	93	06											
BALI	100	99												
TRX ASTREA GRAND SUPRA	100	97	98											
TRX ASTREA SUPRA NF	100	99												
@	125	00												
ANF 125 INNOVA	125	03												
CA 125 REBEL	125	95												
CA S-T REBEL	125	95	98											
CA S-T REBEL	125	99												
CB S-J	125	75	79											
CBF 125	125	09												
CBR 125 R	125	04												
CBR 125 R	125	08												
CR RC	125	82		HO-116	146									
CR RD-RE-RF-RG	125	83	86	HO-116	146									
CR RH-J-K-L-M-N-P-R-S-T-X	125	94	00	HO-100	146			HO-101	182	HO-101/C	183			
CRM R	125	90	99	HO-61	145			HO-87	182					
DYLAN	125	01												
GROM 125	125	14												
MSX 125	125	14												
MTX RWF-RWH-RWL	125	83	87											
MTX RWF-RWH-RWL	125	88	94											
NS-FG-FH-RK-RL	125	85	93	HO-59	144			HO-85	181					
NSR-FM-FN	125	88	89	HO-61	145			HO-87	182					
NSR-FM-FN	125	90		HO-61	145			HO-87	182					
NSR-FM-FN	125	91	03	HO-61	145			HO-87	182					
NSR-RK-RL-RM-RN-RP-RR	125	89		HO-117	147									
PANTHEON	125	98	99											
PANTHEON	125	00	02											
PANTHEON	125	03												
PCX 125	125	10												
PS I.	125	06												
SH	125	01	08											
SH	125	09												
SH I.	125	05	08											
VT SHADOW	125	99	05	HO-189	150									
XL V VARADERO	125	01	05	HO-189	150									
XL-K2- K4-SZ-SA	125	78	80											
XL-SB-SC	125	81	82											
XLR RW	125	98	01											
XR L3/L4/L5	125	03												
@	150	00												
CBR R 150	150	00												
CRF R	150	07	09											
DYLAN	150	01												
PANTHEON	150	98	02											
PANTHEON	150	03												
PS I.	150	06												
SH	150	01	08											
SH	150	09												
SH I.	150	05												
CM-TA-TB CUSTOM	200	79	85											

FRENI - BRAKES

VALVOLE - REEDS

COLLETTORI INTAKE MANIFOLDS

FERMACOPERTONI TIRE LOCKS

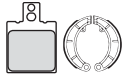

Pastiglie/Ganasce Anteriori
Front Brake Pads/Shoes

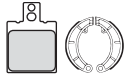

Pastiglie/Ganasce Posteriori
Rear Brake Pads/Shoes



Dischi Freno Anteriori
Front Brake Disk



Dischi Freno Posteriori
Rear Brake Disk



Lamelle
Reeds



Valvole Lamellari
Reed Valve



Valvola Power Reed
Power Reed Valve



Collettori Aspirazione
Intake Manifolds



Fermacopertoni Anteriori
Front Tire Locks



Fermacopertoni Posteriori
Rear Tire Locks

COD	PAG	COD	PAG	COD	PAG	COD	PAG	COD	PAG	COD	PAG	COD	PAG	COD	PAG	COD	PAG	COD	PAG
				DF-4	293			83	314					VE-371	329				
P.073	216																		
P.076	218	P.093	221					09	310										
P.260	277																		
P.003	208																		
P.260	277																		
P.076	218	P.093	221																
01200	288																		
01200	288																		
P.074	216			DF-5	293			83	314					VE-371	329				
01200	288	01200	288																
P.166	235	01200	288																
P.206	254			DF-24	301														
P.249	273																		
P.259	277																		
P.166	235																		
P.074	216																		
01200	288	01200	288																
P.249	273																		
P.249	273																		
P.249	273	P.252	274																
								15	311	HO-107	319	PWR-1	322			MA-139	332	MA-140	333
P.063	212							15	311	HO-107	319	PWR-1	322			MA-139	332	MA-140	333
P.190	246	P.093	221					15	311	HO-107	319	PWR-1	322			MA-139	332	MA-140	333
P.074	216	P.099	223					15	311	HO-107	319	PWR-1	322			MA-139	332	MA-140	333
P.206	254	0280	287	DF-24	301			15	311	HO-107	319	PWR-1	322			MA-139	332	MA-140	333
P.249	273	P.252	274																
		P.252	274																
P.063	212							09	310										
P.074	216							09	310										
P.074	216							09	310										
P.074	216	P.012	208					15	311	HO-107	319	PWR-1	322						
		P.099	223					15	311	HO-107	319	PWR-1	322						
P.074	216	P.099	223					15	311	HO-107	319	PWR-1	322						
P.074	216	P.012	208					15	311	HO-107	319	PWR-1	322						
P.194	248			DF-3	293														
P.194	248			DF-3	293														
P.194	248	P.103	223	DF-3	293	DF-26	301												
P.239	267																		
P.206	254	0280	287	DF-24	301														
P.206	254	0280	287	DF-24	301														
P.227	261	P.228	262																
P.206	254	0280	287	DF-24	301														
P.166	235																		
P.166	235							15	311	HO-107	319	PWR-1	322						
								15	311	HO-107	319	PWR-1	322						
								15	311	HO-107	319	PWR-1	322						
P.190	246																		
P.190	246																		
P.206	254	0280	287	DF-24	301														
P.249	273																		
		P.202	251																
P.206	254	0280	287	DF-24	301														
P.194	248			DF-3	293														
P.194	248	P.134	228	DF-3	293	DF-26	301												
P.206	254	0280	287	DF-24	301														
P.206	254	0280	287	DF-24	301														
P.227	261	P.228	262																
P.206	254	0280	287	DF-24	301														
P.045	211																		

MARCA - MODELLO MAKE - MODEL



Serie
Dischi Rivestiti
Friction Plate Kit



RACING
Serie
Dischi Rivestiti
Friction Plate Kit



Serie Completa
Dischi Frizione
Clutch Plates
Complete Set



RACING
Serie Completa
Dischi Frizione
Clutch Plates
Complete Set



Frizione
Antisaltemamento
Slipper Clutches



Carter Frizione
Clutch Covers

HONDA	CC	MY	COD	PAG	COD	PAG	COD	PAG	COD	PAG	COD	PAG	COD	PAG	
MTX RWD	200	83	84												
MTX RWF	200	83	86												
ATC RF-RG-RH	250	85	87	HO-167	149										
CB FT/FV/FX/FY "HORNET"	250	96	01												
CB-N-T	250	92	99												
CB-RSA-RSD	250	81	84	HO-59	144			HO-85	181						
CB-T-N-NA-NB	250	78	82	HO-63	145										
CBR 250 R ABS	250	11													
CBX-RSE	250	84	86	HO-166	149										
CD-UJ-UK	250	88	93												
CL-SC	250	82	84	HO-59	144			HO-85	181						
CM-TB CUSTOM	250	82	84												
CMX 250 C REBEL	250	96													
CMX-CT-V	250	95	98												
CR RD-RK	250	83	86	HO-97	145			HO-99	182						
CR RD-RK	250	87	89	HO-97	145			HO-99	182						
CR RL-RM-RN-RP	250	90	93	HO-119	147			HO-121	183						
CR RR-RX	250	94	01	HO-119	147			HO-121	183						
CR RR-RX	250	02		HO-119	147			HO-121	183						
CR RR-RX	250	02	07												
CRF 250 L	250	14													
CRF 250 M	250	14													
CRF R	250	04		HO-182	149			HO-183	183	HO-183/C	184	HO-193	197	HO-198	202
CRF X	250	04										HO-193	197	HO-198	202
CRF X	250	04	09												
FORESIGHT	250	97	00												
FORESIGHT	250	01													
FORZA	250	00	04												
FORZA EX	250	05	06												
FORZA X - Z	250	05													
JAZZ	250	01													
REFLEX	250	01	04												
REFLEX ABS	250	05	06												
REFLEX SPORT ABS	250	05	06												
TRX R	250	88	89	HO-167	149										
TRX RG-RH-RJ-RK	250	86	89	HO-167	149										
VTR	250	98													
XL-RE RH PROLINK	250	84	88												
XL-SB-RC	250	81	82	HO-59	144			HO-85	181						
XR RB-RC-RD	250	81	82	HO-59	144			HO-85	181						
XR RE-RF	250	84	85												
XR RG-H-J-K-L-M-N-P-R-S	250	86	87	HO-116	146										
XR RT-RX	250	96	02	HO-116	146										
XR RT-RX	250	03		HO-116	146										
CBR 300 F	300	14													
CBR 300 R	300	15													
SH I.E.	300	06													
TRX EX	300	93	05	HO-116	146										
TRX FWJ FOURTRAX	300	88	99	HO-62	145										
CB-SG	350	86	88	HO-63	145										
TRX G-H-J-K-L	350	86	92	HO-62	145										
XL R	350	84	85												
XR RD-RE	350	83	84	HO-116	146										
CB FOUR	400	97	00												
CB SBS	400	05													
CB SF "SUPERFOUR"	400	92	95												
CB SFX/SFY "SUPERFOUR"	400	99	03												
CB SS	400	02		HO-117	147										
CB-F-F1-F2	400	79	81	HO-63	145										
CB-T-N-NA-NC	400	78	83	HO-63	145										

FRENI - BRAKES

VALVOLE - REEDS

COLLETTORI INTAKE MANIFOLDS

FERMACOPERTONI TIRE LOCKS

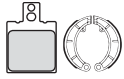

Pastiglie/Ganasce Anteriori
Front Brake Pads/Shoes

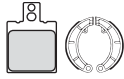

Pastiglie/Ganasce Posteriori
Rear Brake Pads/Shoes



Dischi Freno Anteriori
Front Brake Disk



Dischi Freno Posteriori
Rear Brake Disk



Lamelle
Reeds



Valvole Lamellari
Reed Valve



Valvola Power Reed
Power Reed Valve



Collettori Aspirazione
Intake Manifolds



Fermacopertoni Anteriori
Front Tire Locks



Fermacopertoni Posteriori
Rear Tire Locks

COD	PAG	COD	PAG	COD	PAG	COD	PAG	COD	PAG	COD	PAG	COD	PAG	COD	PAG	COD	PAG	COD	PAG
								09	310										
								09	310										
P.063	212																		
		P.103	223																
P.156	232																		
P.045	211																		
P.045	211																		
		P.256	276																
P.082	219																		
P.045	211																		
P.259	277																		
P.166	235																		
P.063	212																		
		P.093	221															MA-139	332
		P.093	221															MA-139	332
		P.093	221															MA-139	332
P.190	246	P.093	221															MA-139	332
																		MA-139	332
P.190	246	P.202	251																
		P.252	274																
		P.252	274																
P.190	246	P.202	251																
P.190	246	P.202	251																
P.194	248																		
P.194	248	P.103	223	DF-25	301	DF-26	301												
				DF-25	301	DF-26	301												
P.227	261	P.228	262			DF-30	303												
P.227	261	P.228	262	DF-25	301	DF-30	303												
P.194	248	P.103	223	DF-25	301	DF-26	301												
P.194	248																		
P.227	261	P.228	262																
P.227	261	P.228	262																
P.156	232	P.134	228																
P.063	212																		
P.063	212																		
P.063	212	P.093	221																
P.190	246	P.093	221																
P.190	246	P.202	251																
		P.256	276																
		P.256	276																
P.227	261	P.228	262	DF-37	305	DF-37	305												
P.076	218	P.076	218																
P.073	216																		
P.108	224	P.103	223																
P.187	245	P.134	228																
P.168	236	P.103	223																
P.187	245	P.218	259																
P.187	245																		

MARCA - MODELLO MAKE - MODEL



Serie
Dischi Rivestiti
Friction Plate Kit



RACING
Serie
Dischi Rivestiti
Friction Plate Kit



Serie Completa
Dischi Frizione
Clutch Plates
Complete Set



RACING
Serie Completa
Dischi Frizione
Clutch Plates
Complete Set



Frizione
Antisaltemento
Slipper Clutches



Carter Frizione
Clutch Covers

HONDA	CC	MY	COD	PAG	COD	PAG	COD	PAG	COD	PAG	COD	PAG	COD	PAG
CBR R	400	87	89											
CBR RR	400	90	94	HO-117	147									
CM A/T	400	79												
NS-RF-RG	400	85	88	HO-165	148									
NX 4 FALCON	400	03												
SILVER WING	400	06												
TRX E	400	99	02	HO-167	149									
TRX FWS/T/V/W/X/Y	400	95	00	HO-116	146									
VT SHADOW	400	97	01											
VT SHADOW SLASHER	400	02												
XR R	400	96	03	HO-167	149									
CB-DX-K	450	89	92	HO-63	145									
CRF R	450	02	08								HO-192	196	HO-199	202
CRF R	450	02		HO-205	150									
CRF R	450	09	12								HO-207	198	HO-208	203
CRF R	450	13	16								HO-212	199	HO-208	203
CRF X	450	05		HO-205	150						HO-201	198	HO-203	202
CRF X	450	05	09											
TRX ESW/ESX/ESY	450	98	01	HO-116	146									
TRX R	450	05									HO-197	197	HO-199	202
CR RD	480	83		HO-97	145		HO-99	182						
CB 500 F	500	13												
CB 500 X	500	13												
CB R-T	500	94	96	HO-117	147									
CB V/W/SW/X/SX/Y/SY	500	97	03	HO-117	147									
CB-T	500	78		HO-16	144									
CBF 4	500	05		HO-117	147									
CBF A4/A5	500	04		HO-117	147									
CBF A4/A5/A6 ABS	500	04												
CR RE-RG-RH-RJ-RK	500	84	86	HO-97	145		HO-99	182						
CR RL-RM-RN-RP-RR-RS-RT	500	94	00	HO-119	147		HO-121	183						
FT-C	500	82	84	HO-63	145									
VT-ED-EF EURO SPORT	500	82	88	HO-61	145		HO-87	182						
XL-SZ-SB-RC	500	80	82	HO-63	145									
CB AF7 HORNET ABS	600	07		HO-134	147									
CB F HORNET	600	07	09											
CB F2Y/Y21/F22 S HORNET	600	00	05	HO-134	147									
CB F7 HORNET	600	00	06	HO-134	147									
CB FW/FX HORNET	600	98	99	HO-134	147									
CB FY/F1-F6 HORNET	600	00	06	HO-134	147									
CBF N4/NA4/S4/SA4/N5/NA5	600	04		HO-134	147									
CBR F	600	89	90											
CBR F	600	91	94	HO-134	147									
CBR F	600	95	98	HO-134	147									
CBR F	600	99	01	HO-167	149									
CBR F4 SPORT	600	02	03	HO-148	148									
CBR RR	600	03	04	HO-148	148									
CBR RR	600	05	06	HO-148	148									
CBR RR	600	07		HO-148	148									
NTV REVERE-J-K	600	88	89	HO-148	148									
NTV-L-M-N	600	90	92	HO-148	148									
SILVER WING	600	01												
SILVER WING ABS	600	01												
VT SHADOW-CN-CV	600	91	93	HO-117	147									
VT SHADOW-CN-CV	600	94	01	HO-117	147									
XL TRANSALP-VH-VV	600	97	00	HO-117	147									
XL-LMF-LMH-RMG	600	85	87	HO-97	145		HO-99	182						
XL-RD-RE-RF-RG	600	83	87	HO-97	145		HO-99	182						
XR RE-RH	600	83	87	HO-97	145		HO-99	182						
XR RE-RH	600	88	90	HO-97	145		HO-99	182						

FRENI - BRAKES

VALVOLE - REEDS

COLLETTORI INTAKE MANIFOLDS

FERMACOPERTONI TIRE LOCKS

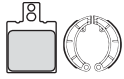

Pastiglie/Ganasce Anteriore
Front Brake Pads/Shoes

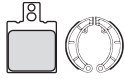

Pastiglie/Ganasce Posteriori
Rear Brake Pads/Shoes



Dischi Freno Anteriore
Front Brake Disk



Dischi Freno Posteriori
Rear Brake Disk



Lamelle
Reeds



Valvole Lamellari
Reed Valve



Valvola Power Reed
Power Reed Valve



Collettori Aspirazione
Intake Manifolds



Fermacopertoni Anteriore
Front Tire Locks



Fermacopertoni Posteriori
Rear Tire Locks

COD	PAG	COD	PAG	COD	PAG	COD	PAG	COD	PAG	COD	PAG	COD	PAG	COD	PAG	COD	PAG	COD	PAG		
P.108	224	P.103	223																		
P.108	224	P.103	223																		
P.045	211																				
P.190	246	P.093	221																		
P.076	218	P.076	218	DF-37	305																
P.108	224																				
P.108	224																				
P.190	246	P.093	221																		
P.190	246	P.202	251																		
P.190	246	P.202	251																		
		P.256	276																		
		P.256	276																		
P.192	247	P.172	238																		
		P.134	228																		
		P.134	228																		
P.227	261	P.134	228																		
P.063	212	P.093	221															MA-139	332	MA-152	333
P.190	246	P.093	221															MA-139	332	MA-152	333
P.227	261	P.134	228																		
P.108	224	P.223	260																		
P.108	224	P.134	228																		
P.108	224	P.224	261																		
P.108	224	P.134	228																		
P.108	224	P.134	228																		
P.108	224	P.134	228																		
		P.103	223																		
		P.134	228																		
P.108	224	P.134	228																		
P.187	245	P.134	228																		
P.187	245	P.134	228																		
P.187	245	P.134	228																		
P.216	258	P.134	228																		
P.216	258	P.224	261																		
		P.103	223																		
P.164	234	P.103	223																		
P.194	248			DF-37	305																
P.194	248			DF-37	305																
P.082	219																				
P.108	224																				
P.190	246	P.103	223																		
P.063	212																				
P.063	212																				

MARCA - MODELLO MAKE - MODEL



Serie
Dischi Rivestiti
Friction Plate Kit



RACING
Serie
Dischi Rivestiti
Friction Plate Kit



Serie Completa
Dischi Frizione
Clutch Plates
Complete Set



RACING
Serie Completa
Dischi Frizione
Clutch Plates
Complete Set



Frizione
Antisaltemento
Slipper Clutches



Carter Frizione
Clutch Covers

HONDA	CC	MY	COD	PAG	COD	PAG	COD	PAG	COD	PAG	COD	PAG	COD	PAG
XR RE-RH	600	91	93	HO-97	145			HO-99	182					
XR RE-RH	600	94	99	HO-97	145			HO-99	182					
CB	650	79	85											
CB 650 F	650	14												
CBR 650 F	650	14												
FX VIGOR	650	99	03	HO-97	145			HO-99	182					
NT DEAUVILLE	650	98	01	HO-148	148									
NT DEAUVILLE	650	02	04	HO-148	148									
NTV REVERE-P-S-T-V	650	88	90	HO-148	148									
NTV V	650	02		HO-148	148									
NX DOMINATOR-T-K-L-M-N	650	87		HO-97	145			HO-99	182					
SLR	650	97	98	HO-97	145			HO-99	182					
XL TRANSALP-VH-WV	650	00	05	HO-148	148									
XR RY/R1-R7	650	00	07											
XRV AFRICA TWIN	650	88	89	HO-148	148									
CTX 700	700	14												
CTX 700 D ABS w/DCT	700	14												
CTX 700 N	700	14												
CTX 700 ND ABS w/DCT	700	14												
NM4 700 VULTUS ABSw/DCT	700	15												
NTV V DEAUVILLE	700	06												
VFR F-F2	700	86	87											
CB NIGHTHAWK	750	91	03											
CB SEVEN FIFTY	750	92	02											
CB-FA-FB-F2C	750	79	82	HO-106	146									
CB-K1	750	69	70	HO-16	144									
CB-KZ	750	80		HO-106	146									
CBX-FE-FG	750	83	87	HO-112	146									
NC 750 D INTEGRA	750	14												
NC 750 S w/DCT	750	14												
PC "PACIFIC COAST"	750	89	97	HO-149	148									
VF C MAGNA	750	93	99	HO-134	147									
VF-CH-CJ	750	87	88	HO-112	146									
VF-FD-FE	750	83	85	HO-149	148									
VF-SC	750	82	85	HO-112	146									
VFR F	750	85		HO-134	147									
VFR F	750	86	87	HO-134	147									
VFR F	750	88	97	HO-134	147									
VFR-RJ-RK (RC30) RL	750	88	92	HO-163	148									
VFR-T-V	750	96	97	HO-134	147									
VT SHADOW AERO C4	750	04												
VT SHADOW C-C2	750	97	01	HO-148	148									
VT SHADOW DC	750	02		HO-148	148									
VT SHADOW SPIRIT C2	750	07												
XRV-L V AFRICA TWIN	750	90	93	HO-149	148									
800 CROSSRUNNER	800	11												
VFR 800 FI	800	14												
VFR 800 X CROSSRUNNER	800	15												
VFR A2/A3	800	03		HO-148	148									
VFR A6/A7	800	06	07											
VFR F	800	98	99	HO-134	147									
VFR F	800	00	02											
CB F2/F3/F4/F5 HORNET	900	01	05	HO-148	148									
CB-FZ-FA-FB-F2B-F2C-FD	900	81	85	HO-106	146									
CBR RR	900	92	95	HO-134	147									
CBR RR	900	98	99											
CBR RR	900	96	99	HO-176	149									
CBR RR	900	96	97											
CBR RR	929	00	01	SU-63	159									
CBR RR	954	02	03	SU-63	159									

FRENI - BRAKES

VALVOLE - REEDS

COLLETTORI INTAKE MANIFOLDS

FERMACOPERTONI TIRE LOCKS

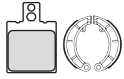

Pastiglie/Ganasce Anteriori
Front Brake Pads/Shoes

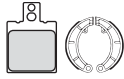

Pastiglie/Ganasce Posteriori
Rear Brake Pads/Shoes



Dischi Freno Anteriore
Front Brake Disk



Dischi Freno Posteriori
Rear Brake Disk



Lamelle
Reeds



Valvole Lamellari
Reed Valve



Valvola Power Reed
Power Reed Valve



Collettori Aspirazione
Intake Manifolds



Fermacopertoni Anteriore
Front Tire Locks



Fermacopertoni Posteriori
Rear Tire Locks

COD	PAG	COD	PAG	COD	PAG	COD	PAG	COD	PAG	COD	PAG	COD	PAG	COD	PAG	COD	PAG	COD	PAG
		P.093	221																
P.190	246	P.093	221																
P.045	211																		
		P.256	276																
		P.256	276																
P.192	247	P.172	238																
P.192	247	P.103	223																
P.182	242	P.182	242																
P.156	232	P.103	223																
P.182	242	P.194	248																
P.192	247	P.172	238																
P.192	247	P.172	238																
P.190	246	P.103	223																
P.190	246	P.093	221																
P.082	219	P.103	223																
		P.256	276																
		P.256	276																
		P.256	276																
		P.256	276																
		P.256	276																
P.227	261	P.182	242																
P.082	219																		
P.108	224	P.134	228																
P.108	224	P.134	228																
P.045	211																		
		P.256	276																
		P.256	276																
P.108	224																		
P.108	224																		
P.082	219																		
P.108	224																		
P.108	224																		
P.108	224																		
P.190	246	P.103	223																
		P.236	266																
		P.236	266																
		P.236	266																
P.194	248	P.194	248																
P.227	261	P.182	242																
P.182	242	P.182	242																
P.182	242	P.182	242																
		P.134	228																
		P.134	228																
P.187	245	P.134	228																
		P.134	228																
P.187	245	P.134	228																
P.187	245	P.134	228																

MARCA - MODELLO MAKE - MODEL



Serie
Dischi Rivestiti
Friction Plate Kit



RACING
Serie
Dischi Rivestiti
Friction Plate Kit



Serie Completa
Dischi Frizione
Clutch Plates
Complete Set



RACING
Serie Completa
Dischi Frizione
Clutch Plates
Complete Set



Frizione
Antisaltamento
Slipper Clutches



Carter Frizione
Clutch Covers

HONDA	CC	MY	COD	PAG	COD	PAG	COD	PAG	COD	PAG	COD	PAG	COD	PAG
CB 1000 R	1000	08												
CB 1000 R ABS	1000	08												
CB FR-FT	1000	93	97	HO-145	147									
CBF F A6/A7	1000	06	07											
CBR F DUAL	1000	93	99	HO-145	147									
CBR FH-FJ-FK-FL-FV	1000	87	88	HO-145	147									
CBR RR	1000	04	05											
CBR RR	1000	06	08											
VARADERO	1000	99	00											
VF FE-FF-RE-RFRG	1000	84	86	HO-145	147									
VTR F FIRESTORM	1000	97	05											
VTR SP 1	1000	00	01											
VTR SP 2	1000	02	05											
XL VA4-VA5-VA6-VA7 VARADERO	1000	04	07											
XL VX/XY/V1-V5 VARADERO	1000	99	05											
CB-RB2-RC2	1100	80	81	HO-106	146									
CBR XXV/XXW BLACKBIRD	1100	97	98											
CBR XXX/XXY BLACKBIRD	1100	99	05											
ST L R-AN V PAN EUROPEAN	1100	90	95											
VT C3 SHADOW	1100	97	00	HO-145	147									
VT C4 SHADOW SABRE	1100	04		HO-145	147									
VFR 1200 F	1200	10												
VT MAGNA	1200	95	99											
CB A5	1300	04												
CB F1	1300	01	02											
CB F3/F13	1300	03												
CB SS	1300	04												
ST PAN EUROPEAN	1300	02												
VTX	1300	03												
GL CV/CW/CX/CY/C1/C2	1500	97	03	HO-171	149									
GL J-K-L SEN-SEV GOLDWING	1500	88	00	HO-171	149									
GL GOLDWING	1800	01	05											
VTX C2/C3/C4	1800	02	04											
HOREX	CC	MY												
REBELL 80 T	80	86												
SPORT 80 L	80	86												
IMPERATOR 125	125	96												
REGENT 125	125	96												
E 560	560	86												
COLUMBUS 600	600	87												
HUSABERG	CC	MY												
SM S	125	00												
FC	350	95												
FE	350	95												
MC	350	91	93											
MC	350	94												
FE	390	10												
FC	400	99	02											
FE	400	00												
FC	450	98	03											
FE E	450	04	08											
FE E	450	09												
FX	450	10												
FX	450	03	09											
FC	470	01												
FX E	470	01												
CROSS	500	93												
MC	500	91												
FC	501	95												
FE	501	95												

FRENI - BRAKES

VALVOLE - REEDS

COLLETTORI INTAKE MANIFOLDS

FERMACOPERTONI TIRE LOCKS

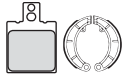

Pastiglie/Ganasce Anteriori
Front Brake Pads/Shoes

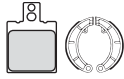

Pastiglie/Ganasce Posteriori
Rear Brake Pads/Shoes



Dischi Freno Anteriore
Front Brake Disk



Dischi Freno Posteriori
Rear Brake Disk



Lamelle
Reeds



Valvole Lamellari
Reed Valve



Valvola Power Reed
Power Reed Valve



Collettori Aspirazione
Intake Manifolds



Fermacopertoni Anteriore
Front Tire Locks



Fermacopertoni Posteriori
Rear Tire Locks

COD	PAG	COD	PAG	COD	PAG	COD	PAG	COD	PAG	COD	PAG	COD	PAG	COD	PAG	COD	PAG	COD	PAG
		P.236	266																
		P.236	266																
		P.134	228																
P.227	261	P.227	261																
P.082	219																		
P.216	258	P.134	228																
P.216	258	P.224	261																
P.182	242	P.194	248																
		P.134	228																
P.187	245	P.134	228																
P.187	245	P.134	228																
P.227	261	P.182	242																
P.182	242	P.182	242																
P.182	242	P.182	242																
P.182	242	P.182	242																
		P.134	228																
		P.236	266																
P.108	224	P.156	232																
P.187	245	P.134	228																
P.187	245	P.218	259																
P.187	245	P.134	228																
P.187	245	P.134	228																
P.182	242	P.182	242																
		P.134	228																
P.108	224																		
P.082	219																		
P.182	242	P.182	242																
P.182	242	P.182	242																
P.245	270	P.245	270																
P.245	270	P.245	270																
P.245	270																		
P.245	270																		
P.245	270	P.245	270																
P.245	270	P.245	270																
P.143	230	P.172	238																
P.143	230	P.172	238																
P.143	230	P.172	238																
		P.075	217																
		P.172	238																
		P.203	252																
P.143	230	P.172	238																
P.143	230	P.172	238																
P.143	230	P.172	238																
P.143	230	P.172	238																
		P.203	252																
		P.203	252																
P.143	230	P.172	238																
P.143	230	P.172	238																
P.143	230	P.172	238																
P.143	230	P.075	217																
		P.075	217																
P.143	230	P.172	238																
P.143	230	P.172	238																

MARCA - MODELLO MAKE - MODEL



Serie
Dischi Rivestiti
Friction Plate Kit



RACING
Serie
Dischi Rivestiti
Friction Plate Kit



Serie Completa
Dischi Frizione
Clutch Plates
Complete Set



RACING
Serie Completa
Dischi Frizione
Clutch Plates
Complete Set



Frizione
Antisaltellamento
Slipper Clutches



Carter Frizione
Clutch Covers

HUSABERG	CC	MY	COD	PAG	COD	PAG	COD	PAG	COD	PAG	COD	PAG	COD	PAG
MC	501	89	93											
MC	501	94												
MC ENDURO	501	91												
FC	550	01												
FE E	550	04												
FE E	570	09												
FS	570	10												
FC	600	95												
FE	600	95												
FE E	650	01												
FS	650	01												
FX E	650	01												
HUSQVARNA	CC	MY												
SM	50	02												
WR	50	02												
WRS	50	98	00											
TE	100	05												
CR	125	92	95	HU-42	150			HU-41	185					
CR	125	96	04	HU-42	150			HU-41	185					
CR	125	05		HU-42	150			HU-41	185					
SM S	125	02		HO-100	146			HO-101	182	HO-101/C	183			
WR	125	95	05	HO-100	146			HO-101	182	HO-101/C	183			
WR	125	06		HO-100	146			HO-101	182	HO-101/C	183			
WRE	125	94	00	HO-100	146			HO-101	182	HO-101/C	183			
WRE	125	01		HO-100	146			HO-101	182	HO-101/C	183			
WXE	125	07		HO-100	146			HO-101	182	HO-101/C	183			
CR	250	92	95	HU-39	150			HU-38	184					
CR	250	96	04	HU-39	150			HU-50	185	HU-50/C	186			
CR	250	05		HU-39	150			HU-50	185	HU-50/C	186			
TC	250	02	03											
TC	250	04												
TE	250	02	05											
TE	250	06												
TXC CROSS COUNTRY	250	08												
WR	250	84	90											
WR	250	91	92	HU-39	150			HU-38	184					
WR	250	93	05	HU-39	150			HU-50	185	HU-50/C	186			
WR	250	06		HU-39	150			HU-50	185	HU-50/C	186			
WR	260	91		HU-39	150			HU-38	184					
WR	300	09												
XC-W	300	10												
TE	310	09												
TE	350	95	97	HU-39	150			HU-50	185	HU-50/C	186			
CR	360	92	93	HU-39	150			HU-50	185	HU-50/C	186			
CR	360	94		HU-39	150			HU-50	185	HU-50/C	186			
WR	360	92	93	HU-39	150			HU-50	185	HU-50/C	186			
WR	360	94		HU-39	150			HU-50	185	HU-50/C	186			
SM R	400	02												
TE	400	02												
XC-W	400	10												
TE	410	94	05	HU-39	150			HU-50	185	HU-50/C	186			
TE	410	06		HU-39	150			HU-50	185	HU-50/C	186			
TE E	410	01		HU-39	150									
SM R	450	03	06	HU-51	151									
SM R	450	05	07									HU-52	199	
SM R	450	07		HU-51	151									
SM R	450	08	10									HU-53	200	
SM RR	450	07		HU-51	151									
SM RR	450	07										HU-52	199	
SM RR	450	08	10									HU-53	200	

FRENI - BRAKES

VALVOLE - REEDS

COLLETTORI INTAKE MANIFOLDS

FERMACOPERTONI TIRE LOCKS

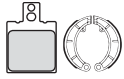

Pastiglie/Ganasce Anteriori
Front Brake Pads/Shoes

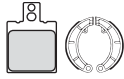

Pastiglie/Ganasce Posteriori
Rear Brake Pads/Shoes



Dischi Freno Anteriore
Front Brake Disk



Dischi Freno Posteriori
Rear Brake Disk



Lamelle
Reeds



Valvole Lamellari
Reed Valve



Valvola Power Reed
Power Reed Valve



Collettori Aspirazione
Intake Manifolds



Fermacopertoni Anteriore
Front Tire Locks



Fermacopertoni Posteriori
Rear Tire Locks

COD	PAG	COD	PAG	COD	PAG	COD	PAG	COD	PAG	COD	PAG	COD	PAG	COD	PAG	COD	PAG	COD	PAG
		P.075	217																
		P.172	238																
		P.075	217																
P.143	230	P.172	238																
P.143	230	P.172	238																
		P.203	252																
		P.203	252																
P.143	230	P.172	238																
P.143	230	P.172	238																
P.143	230	P.172	238																
P.143	230	P.172	238																
P.143	230	P.172	238																
P.143	230	P.172	238																
P.133	227	P.065	213																
P.133	227	P.065	213																
P.065	213			DF-1	292														
P.200	250																		
P.086	220	P.076	218					81	314							MA-139	332	MA-152	333
P.143	230	P.172	238					81	314							MA-139	332	MA-152	333
P.143	230	P.203	252					81	314							MA-139	332	MA-152	333
P.143	230	P.172	238																
P.143	230	P.172	238					81	314							MA-139	332	MA-152	333
P.143	230	P.203	252					81	314							MA-139	332	MA-152	333
P.143	230	P.172	238					81	314							MA-139	332	MA-152	333
P.143	230	P.172	238																
P.133	227	P.093	221																
P.086	220	P.076	218													MA-139	332	MA-152	333
P.143	230	P.172	238																
P.143	230	P.203	252																
P.143	230	P.172	238																
P.143	230	P.203	252																
P.143	230	P.172	238																
P.143	230	P.203	252																
P.143	230	P.203	252																
P.012	208															MA-139	332	MA-152	333
		P.075	217													MA-139	332	MA-152	333
P.143	230	P.172	238															MA-152	333
P.143	230	P.203	252													MA-139	332	MA-152	333
		P.075	217													MA-139	332	MA-152	333
		P.203	252																
		P.203	252																
		P.203	252																
P.143	230	P.172	238													MA-139	332	MA-152	333
		P.075	217													MA-139	332	MA-152	333
P.143	230	P.172	238													MA-139	332	MA-152	333
P.086	220	P.076	218													MA-139	332	MA-152	333
P.143	230	P.172	238													MA-139	332	MA-152	333
P.067	214	P.172	238																
P.143	230	P.172	238																
		P.203	252																
P.143	230	P.172	238													MA-139	332	MA-152	333
P.143	230	P.203	252													MA-139	332	MA-152	333
P.143	230	P.172	238													MA-139	332	MA-152	333
P.067	214	P.172	238																
P.211	256	P.203	252																
P.211	256	P.203	252																

MARCA - MODELLO MAKE - MODEL



Serie
Dischi Rivestiti
Friction Plate Kit



RACING
Serie
Dischi Rivestiti
Friction Plate Kit



Serie Completa
Dischi Frizione
Clutch Plates
Complete Set



RACING
Serie Completa
Dischi Frizione
Clutch Plates
Complete Set



Frizione
Antisaltemento
Slipper Clutches



Carter Frizione
Clutch Covers

HUSQVARNA	CC	MY	COD	PAG	COD	PAG	COD	PAG	COD	PAG	COD	PAG	COD	PAG
TC	450	03	04											
TC	450	05	07										HU-52	199
TC	450	05		HU-51	151									
TC	450	08	10										HU-53	200
TE	450	03	04											
TE	450	05	07										HU-52	199
TE	450	05		HU-51	151									
TE	450	08	10										HU-53	200
SM R	510	01	04	HU-51	151									
SM R	510	05	07										HU-52	199
SM R	510	05		HU-51	151									
SM R	510	08	10										HU-53	200
TC	510	04		HU-51	151									
TC	510	05	07										HU-52	199
TC	510	05		HU-51	151									
TC	510	08	10										HU-53	200
TE	510	04												
TE	510	05	07										HU-52	199
TE	510	05		HU-51	151									
TE	510	06		HU-51	151									
TE	510	08	10										HU-53	200
TE LC	510	89		HU-51	151					HU-37/C	184			
SM R	570	01		HU-51	151									
SM S	570	01		HU-51	151									
TC	570	01		HU-51	151									
TE	570	01	04	HU-51	151									
LT	610	00		HU-51	151									
SM R	610	00	05	HU-51	151									
SM R	610	06		HU-51	151									
SM S	610	00	05	HU-51	151									
SM S	610	06		HU-51	151									
TC	610	95		HU-39	150			HU-50	185	HU-50/C	186			
TE	610	92	94					HU-44	185					
TE	610	95	99	HU-39	150			HU-50	185	HU-50/C	186			
TE E	610	00	03	HU-39	150			HU-50	185	HU-50/C	186			
TE E	610	04		HU-51	151									
SM	630	09												
SMR	630	06		HU-51	151									
STR CRC	650	07		HU-51	151									
HYOSUNG	CC	MY												
SB M	50	06												
SD SENSE	50	06												
SF PRIMA	50	06												
FX 110	110	02												
KR 110 MASTER	110	04												
EXIV	125	12												
MS3	125	06	07											
GT COMET	250	02												
GT COMET	250	03												
GT R	250	07												
GV	250	02												
MS3	250	06	07											
GT	650	04												
GT CUSTOM TRENDKILLER	650	07												
GT R	650	05												
GT S	650	05												
GT TTC	650	07												
GT X	650	07												
GV 650 AGUILA	650	04												
GV AGUILA	650	04	05											

FRENI - BRAKES

VALVOLE - REEDS

COLLETTORI INTAKE MANIFOLDS

FERMACOPERTONI TIRE LOCKS

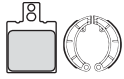

Pastiglie/Ganasce Anteriori
Front Brake Pads/Shoes

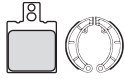

Pastiglie/Ganasce Posteriori
Rear Brake Pads/Shoes



Dischi Freno Anteriore
Front Brake Disk



Dischi Freno Posteriori
Rear Brake Disk



Lamelle
Reeds



Valvole Lamellari
Reed Valve



Valvola Power Reed
Power Reed Valve



Collettori Aspirazione
Intake Manifolds



Fermacopertoni Anteriore
Front Tire Locks



Fermacopertoni Posteriori
Rear Tire Locks

COD	PAG	COD	PAG	COD	PAG	COD	PAG	COD	PAG	COD	PAG	COD	PAG	COD	PAG	COD	PAG	COD	PAG
P.143	230	P.172	238																
P.143	230	P.203	252																
P.143	230	P.172	238																
P.143	230	P.203	252																
P.067	214	P.172	238																
P.211	256	P.172	238																
P.143	230	P.172	238																
P.143	230	P.203	252																
P.143	230	P.172	238																
P.143	230	P.172	238																
P.143	230	P.203	252																
		P.075	217													MA-139	332	MA-152	333
P.067	214	P.172	238																
P.067	214	P.172	238																
P.143	230	P.172	238																
P.143	230	P.172	238																
P.168	236	P.172	238													MA-139	332	MA-152	333
P.067	214	P.172	238													MA-139	332	MA-152	333
P.211	256	P.172	238																
P.168	236	P.172	238													MA-139	332	MA-152	333
P.211	256	P.172	238													MA-139	332	MA-152	333
P.143	230	P.172	238													MA-139	332	MA-152	333
P.086	220	P.003	208													MA-139	332	MA-152	333
P.143	230	P.172	238													MA-139	332	MA-152	333
P.143	230	P.172	238													MA-139	332	MA-152	333
P.143	230	P.172	238													MA-139	332	MA-152	333
P.211	256																		
P.067	214	P.172	238																
P.211	256	P.172	238																
P.030	210																		
P.030	210																		
P.030	210																		
P.260	277																		
P.260	277																		
		P.260	277																
P.073	216	P.073	216																
		P.111	225																
P.133	227	P.133	227																
P.133	227	P.133	227																
P.073	216																		
P.073	216	P.073	216																
P.133	227	P.133	227																
P.133	227	P.133	227																
P.133	227	P.133	227																
P.133	227	P.133	227																
P.133	227	P.133	227																
P.133	227	P.133	227																
P.133	227	P.133	227																
P.133	227	P.243	269																
P.073	216																		

MARCA - MODELLO MAKE - MODEL



Serie
Dischi Rivestiti
Friction Plate Kit



RACING
Serie
Dischi Rivestiti
Friction Plate Kit



Serie Completa
Dischi Frizione
Clutch Plates
Complete Set



RACING
Serie Completa
Dischi Frizione
Clutch Plates
Complete Set



Frizione
Antisaltemento
Slipper Clutches



Carter Frizione
Clutch Covers

HYOSUNG	CC	MY	COD	PAG	COD	PAG	COD	PAG	COD	PAG	COD	PAG	COD	PAG
GV AGUILA	650	06												
ITALJET	CC	MY												
BAZOOKA	50	92	97											
BAZOOKA 2	50	92	97											
CRUISE	50	95												
DRAGSTER	50	98												
FORMULA	50	94	99											
FORMULA L.C.	50	00												
JET-SET	50	03												
PISTA	50	92												
TORPEDO 2T	50	00												
TORPEDO NEW 4T	50	01												
VELOCIFERO	50	99												
YANKEE	50	94												
YANKEE 8	50	94												
MILLENNIUM 2T	100	02												
DRAGSTER L.C.	125	99												
DRAGSTER L.C.	125	00	03											
FORMULA	125	97												
JET-SET	125	02												
JUPITER	125	02												
MILLENNIUM 4T	125	00	01											
TORPEDO 4T	125	99	02											
JET-SET	150	02												
JUPITER	150	02												
MILLENNIUM 4T	150	00	01											
MILLENNIUM 4T	150	02												
DRAGSTER L.C.	180	99												
DRAGSTER L.C.	180	00	03											
JUPITER	250	02												
BAZOOKA	650	06												
GRIFON	650	06												
GRIFON	900	00												
KAWASAKI	CC	MY												
AR 50	50	81												
AR A1-C1-C10	50	81	97											
KMX 50	50	88												
KSR 50 I/II	50	90												
KXF	50	07	09											
KX	65	00												
AR 80	80	81												
AR A1-C1-C8	80	81	92											
KD 80	80	88												
KX 80	80	88												
KX 80 E2	80	84												
KX E2	80	84	86											
KX E3-G1-G2-J1-J2	80	85	87											
KX L1-L2-L3/R1-R7	80	88	97											
KX W1-W2-W3	80	98	00											
KX A1-A5/B1-B5	85	01	05											
KXF	90	07												
KH G4	100	83												
KH G5/G8	100	84	87											
KX 100	100	88												
KX A1-A2/B1-B7	100	89	97											
KX C1/C2/C3	100	98	01											
AR A1-A8-B1-B8	125	83	94											
BN ELIMINATOR A1-A2	125	98	99											
BN ELIMINATOR A3	125	00												
KDX 125 A1	125	90												

FRENI - BRAKES

VALVOLE - REEDS

COLLETTORI INTAKE MANIFOLDS

FERMACOPERTONI TIRE LOCKS

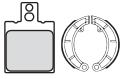

Pastiglie/Ganasce Anteriori
Front Brake Pads/Shoes

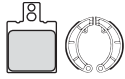

Pastiglie/Ganasce Posteriori
Rear Brake Pads/Shoes



Dischi Freno Anteriore
Front Brake Disk



Dischi Freno Posteriori
Rear Brake Disk



Lamelle
Reeds



Valvole Lamellari
Reed Valve



Valvola Power Reed
Power Reed Valve



Collettori Aspirazione
Intake Manifolds



Fermacopertoni Anteriore
Front Tire Locks



Fermacopertoni Posteriori
Rear Tire Locks

COD	PAG	COD	PAG	COD	PAG	COD	PAG	COD	PAG	COD	PAG	COD	PAG	COD	PAG	COD	PAG	COD	PAG
P.133	227	P.133	227																
P.141	229			DF-12	297			77	314					FB-134	327				
P.141	229							77	314					FB-134	327				
P.065	213	P.065	213					98	315	FB-146	319			FB-135	328				
		P.139	228					90	314										
P.139	228	P.139	228					90	314										
P.201	251																		
P.141	229			DF-12	297			77	314					FB-134	327				
P.065	213																		
P.065	213							90	314										
								77	314					FB-134	327				
P.141	229			DF-12	297														
P.201	251																		
P.065	213	0278	286			DF-23	300												
P.065	213	P.065	213			DF-23	300												
P.065	213	P.065	213																
P.201	251	0278	286																
P.165	235	P.180	242																
P.075	217																		
P.065	213	0278	286																
P.201	251																		
P.165	235	P.180	242																
P.075	217																		
P.201	251																		
P.065	213	0278	286																
P.065	213	P.065	213			DF-23	300												
P.165	235	P.209	255																
P.133	227	P.133	227																
P.133	227	P.133	227																
P.067	214																		
P.260	277																		
P.030	210																		
P.260	277																		
P.260	277																		
		P.210	256																
		P.076	218																
P.260	277																		
P.030	210																		
P.260	277																		
P.030	210																		
P.030	210	P.076	218																
		P.076	218																
		P.076	218																
		P.210	256																
P.075	217																		
P.075	217																		
P.260	277																		
P.030	210	P.076	218																
		P.076	218																
P.075	217							32	313										
P.003	208																		
P.116	226																		
P.260	277																		

MARCA - MODELLO MAKE - MODEL



Serie
Dischi Rivestiti
Friction Plate Kit



RACING
Serie
Dischi Rivestiti
Friction Plate Kit



Serie Completa
Dischi Frizione
Clutch Plates
Complete Set



RACING
Serie Completa
Dischi Frizione
Clutch Plates
Complete Set



Frizione
Antisaltemento
Slipper Clutches



Carter Frizione
Clutch Covers

KAWASAKI	CC	MY	COD	PAG	COD	PAG	COD	PAG	COD	PAG	COD	PAG	COD	PAG
KDX A1-A2-B1-B2	125	91	94	KA-21	152									
KH K2-K10	125	83	98											
KH L1	125	83	86											
KMX 125	125	86												
KMX A1-A2	125	86	87											
KMX A3-A4-A5	125	88	89											
KMX B1-B2	125	86	87											
KMX B10-B12	125	99	03											
KMX B2-B9	125	88	98											
KX 125 B1	125	81												
KX B1	125	82												
KX B2/C1	125	83	84											
KX D1	125	85		KA-21	152									
KX E1	125	86		KA-21	152									
KX E2/F1	125	87	88	KA-27	153									
KX G1/H1-H2/J1-J2	125	89	94	KA-27	153									
KX K1-K5/L1-L4	125	95	03											
KX M1-M2-M3	125	04												
KDX C1-C2-C3	200	86	88	KA-21	152									
KDX E1-E2-E3-E4	200	89	92	KA-27	153									
KDX E5-E6	200	93	94	KA-27	153									
KDX H1-H5	200	95	99	KA-40	154									
KMX 200	200	88												
KDX R A1-A12	220	97	05	KA-40	154									
BJ ESTRELLA	250	92	98	KA-38	153									
BJ ESTRELLA CUSTOM	250	96	99	KA-38	153									
BJ ESTRELLA RS	250	99	02	KA-38	153									
BJ F1-F2	250	02	03	KA-38	153									
EL D1-D5	250	90	94	KA-24	152									
ER B1-B2-B3 SCORPION	250	83	88											
EX HI-H2	250	90												
GPX R	250	87	89	KA-24	152									
KDX B1	250	81		KA-39	153									
KDX D1	250	91	93											
KL SUPER SHERPA	250	97												
KLX D1-D2	250	93	95	KA-21	152									
KLX F1-F4	250	94	97	KA-21	152									
KLX G1	250	94	99	KA-21	152									
KLX H6	250	05												
KLX J1-J6	250	98	03											
KR A1-A2	250	84	86											
KR B2	250	89	90	KA-44	154									
KR C2-C3	250	90	92	KA-44	154									
KX 250 B1	250	82												
KX B1	250	82												
KX C1	250	83	85											
KX D1	250	85		HO-16	144									
KX D2	250	86		HO-16	144									
KX E1-F1	250	87	88											
KX F	250	04	07											
KX K1	250	94		KA-23	152									
KX K2-K5/L1-L5	250	95	02	KA-23	152									
KX M1-M2/R1	250	03		KA-23	152									
Z A3	250	81												
ZR A1-A5 BALIUS	250	91	95	KA-38	153									
ZR B6 BALIUS II	250	02		KA-38	153									
ZXR	250	89	90	KA-38	153									
ZXR	250	91	95	KA-38	153									
ZXR R	250	91		KA-38	153									
ZZ-R	250	90	03	KA-24	152									

FRENI - BRAKES

VALVOLE - REEDS

COLLETTORI INTAKE MANIFOLDS

FERMACOPERTONI TIRE LOCKS

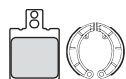

Pastiglie/Ganasce Anteriori
Front Brake Pads/Shoes

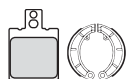

Pastiglie/Ganasce Posteriori
Rear Brake Pads/Shoes



Dischi Freno Anteriore
Front Brake Disk



Dischi Freno Posteriori
Rear Brake Disk



Lamelle
Reeds



Valvole Lamellari
Reed Valve



Valvola Power Reed
Power Reed Valve



Collettori Aspirazione
Intake Manifolds



Fermacopertoni Anteriore
Front Tire Locks



Fermacopertoni Posteriori
Rear Tire Locks

COD	PAG	COD	PAG	COD	PAG	COD	PAG	COD	PAG	COD	PAG	COD	PAG	COD	PAG	COD	PAG	COD	PAG
P.030	210	P.114	225																
P.075	217																		
P.075	217																		
		P.260	277																
P.030	210	P.075	217																
P.030	210	P.075	217																
P.030	210	P.075	217																
		P.075	217																
P.030	210	P.075	217																
P.260	277																		
P.030	210																		
P.075	217																		
P.075	217							32	313							MA-139	332	MA-140	333
P.075	217	P.075	217																
		P.075	217					32	313							MA-139	332	MA-140	333
P.086	220	P.114	225					16	311							MA-139	332	MA-152	333
P.190	246	P.093	221					32	313							MA-139	332	MA-140	333
P.190	246	P.093	221					32	313							MA-139	332	MA-140	333
P.075	217																		
P.075	217	P.114	225																
P.086	220	P.114	225																
P.190	246	P.114	225																
P.260	277																		
P.190	246	P.114	225																
P.075	217	P.075	217																
P.075	217	P.075	217																
P.171	238																		
P.062	212																		
P.062	212																		
		P.075	217																
P.086	220	P.114	225																
		P.075	217																
P.190	246	P.114	225																
P.190	246																		
P.190	246	P.114	225																
P.190	246	P.093	221																
P.190	246	P.093	221																
P.075	217																		
P.107	224																		
P.260	277																		
P.030	210																		
P.075	217																		
P.075	217							16	311							MA-139	332	MA-152	333
P.075	217	P.075	217					16	311										
		P.075	217					16	311							MA-139	332	MA-152	333
P.190	246																		
P.190	246	P.114	225					16	311							MA-139	332	MA-152	333
P.190	246	P.093	221					16	311							MA-139	332	MA-152	333
P.190	246	P.093	221					16	311										
		P.111	225																
		P.075	217																
P.171	238	P.075	217																
		P.075	217																
		P.075	217																
		P.075	217																

MARCA - MODELLO MAKE - MODEL



Serie
Dischi Rivestiti
Friction Plate Kit



RACING
Serie
Dischi Rivestiti
Friction Plate Kit



Serie Completa
Dischi Frizione
Clutch Plates
Complete Set



RACING
Serie Completa
Dischi Frizione
Clutch Plates
Complete Set



Frizione
Antisaltemento
Slipper Clutches



Carter Frizione
Clutch Covers

KAWASAKI	CC	MY	COD	PAG	COD	PAG	COD	PAG	COD	PAG	COD	PAG	COD	PAG
EL	252	97	03	KA-24	152									
KLF A1-A2 BAYOU	300	86	87	KA-38	153									
KLF BI-B17 BAYOU	300	88	04	KA-38	153									
KLF C1-C9 BAYOU LEFT	300	89	99	KA-38	153									
KLF C1-C9 BAYOU RIGHT	300	89	99	KA-38	153									
KLF B1-B7 BAYOU LEFT	400	93	99	KA-39	153									
KLF B1-B7 BAYOU RIGHT	400	93	99	KA-39	153									
Z J1-J3	400	80	83	KA-19	151									
ZR A1-B1	400	83	84	KA-19	151									
ZR E1-E7	400	94	01	KA-19	151									
ZR ZEPHYR	400	97	01	KA-19	151									
ZRX	400	98												
ZRX 400ZR 400 E2	400	99												
ZXR H1-H2	400	89												
ZXR R J1-J2	400	89	94											
ZZ-R	400	90	92	KA-19	151									
ZZ-R	400	93	99	KA-19	151									
EN A1-A6	450	85	90	KA-19	151									
KLX	450	06										KA-48	200	
KX F	450	06		HO-205	150							KA-48	200	
EN A1-A4/B1-B2/C1-C9	500	90	04	KA-19	151									
ER-5	500	97	00	KA-19	151									
ER-5	500	01	05	KA-19	151									
EX A1-A6/D1-D7	500	87	02	KA-19	151									
GPZ S	500	87	93	KA-19	151									
GPZ S	500	94	04	KA-19	151									
KLE A1-A12	500	91	04	KA-19	151									
KX A1-A2	500	83	84											
KX B1-B2	500	85		HO-16	144									
KX B1-B2	500	86		HO-16	144									
KX C1/D1	500	87	88											
KX E1-E5	500	89	93											
KX E6-E7	500	94	95											
KX E8-E16	500	96	04											
Z A1-A3-B1-B2	500	79	81	KA-19	151									
GPZ	550	81	87	KA-19	151									
GT G1-G9	550	83	01	KA-19	151									
Z C1-C2	550	80	81	KA-19	151									
ZR A1-A2	550	83	88	KA-19	151									
ZR ZEPHYR	550	91	93	KA-19	151									
ZR ZEPHYR	550	94	99	KA-19	151									
GPX R	600	88	96	KA-19	151									
GPZ R A1-A5	600	85	90	KA-19	151									
KL A1	600	84		KA-19	151									
KLR B1-B2-B4-B6-B9	600	85	94	KA-19	151									
ZL ELIMINATOR	600	95	98	KA-19	151									
ZX 6R	600	95	97											
ZX 6R	600	98	01											
ZX 6R 600 NINJA	600	07												
ZX 6RR	600	03												
ZX 6RR	600	04	07											
ZX 6RR 600 NINJA	600	05												
ZZR	600	90	92	KA-19	151									
ZZR	600	93	05	KA-19	151									
ZX 6R 636 NINJA	636	03												
ZX-6R	636	02	03											
ZX-6R	636	04	06											
ZX-6R	636	07												
KL B1 TENGAI-B2-B3	650	89	92	KA-19	151									
KLR A1-A19	650	87	05	KA-19	151									

FRENI - BRAKES

VALVOLE - REEDS

COLLETTORI INTAKE MANIFOLDS

FERMACOPERTONI TIRE LOCKS

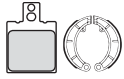

Pastiglie/Ganasce Anteriori
Front Brake Pads/Shoes

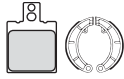

Pastiglie/Ganasce Posteriori
Rear Brake Pads/Shoes



Dischi Freno Anteriori
Front Brake Disk



Dischi Freno Posteriori
Rear Brake Disk



Lamelle
Reeds



Valvole Lamellari
Reed Valve



Valvola Power Reed
Power Reed Valve



Collettori Aspirazione
Intake Manifolds



Fermacopertoni Anteriori
Front Tire Locks



Fermacopertoni Posteriori
Rear Tire Locks

COD	PAG	COD	PAG	COD	PAG	COD	PAG	COD	PAG	COD	PAG	COD	PAG	COD	PAG	COD	PAG	COD	PAG
P.075	217																		
P.086	220																		
P.116	226																		
P.190	246																		
P.116	226																		
P.075	217																		
P.161	234	P.219	259																
P.235	265																		
P.107	224																		
P.107	224																		
P.107	224																		
P.107	224																		
P.062	212																		
P.190	246	P.205	253																
P.062	212																		
P.169	237																		
		P.075	217																
		P.075	217																
P.075	217																		
P.075	217																		
		P.075	217					16	311							MA-139	332	MA-152	333
P.086	220	P.114	225					16	311							MA-139	332	MA-152	333
P.190	246	P.114	225					16	311							MA-139	332	MA-152	333
P.190	246	P.093	221					16	311							MA-139	332	MA-152	333
P.075	217																		
		P.219	259																
P.062	212	P.062	212																
P.075	217																		
P.107	224	P.219	259																
P.161	234	P.219	259																
P.268	281																		
		P.219	259																
		P.219	259																
P.232	264																		
P.107	224																		
P.107	224	P.219	259																
P.232	264																		
P.161	234	P.219	259																
		P.219	259																
		P.219	259																
		P.219	259																
		P.075	217																
		P.075	217																

MARCA - MODELLO MAKE - MODEL



Serie
Dischi Rivestiti
Friction Plate Kit



RACING
Serie
Dischi Rivestiti
Friction Plate Kit



Serie Completa
Dischi Frizione
Clutch Plates
Complete Set



RACING
Serie Completa
Dischi Frizione
Clutch Plates
Complete Set



Frizione
Antisaltemento
Slipper Clutches



Carter Frizione
Clutch Covers

KAWASAKI	CC	MY	COD	PAG	COD	PAG	COD	PAG	COD	PAG	COD	PAG	COD	PAG
KLR C1-C8	650	94	04	KA-23	152									
KLX C1-C3	650	93	97	KA-19	151									
Z B1-B3	650	77	81	KA-4	151									
Z C1-C3	650	77	81	KA-4	151									
Z D2-D3	650	79	83	KA-4	151									
Z F1-F4	650	79	83	KA-4	151									
GPX F1-F2-F3	750	87	89	KA-23	152									
GPZ A1-A5	750	83	87	KA-4	151									
GPZ R G2-G3	750	85	86	KA-23	152									
GPZ R1	750	82		KA-4	151									
GT P1-P5	750	82	90	KA-4	151									
VN A2-A13 VULCAN	750	86	06											
VN A2-A3-A4-A5-A10	750	86	95	KA-23	152									
Z 750 R	750	11												
Z 750 R ABS	750	11												
Z B1-B2	750	77	78	KA-23	152									
Z D1	750	76		KA-23	152									
Z E1/H1 -H2/L1-L4	750	80	84	KA-4	151									
Z N1-N2 SPECTRE	750	82	83	KA-4	151									
Z R	750	11												
Z S PINZA DESTRA	750	05												
Z S PINZA SINISTRA	750	05												
Z Y1 LTD	750	82		KA-23	152									
ZR 7S PINZA DESTRA	750	01	04											
ZR 7S PINZA SINISTRA	750	01	04											
ZX 7R	750	96	03	KA-23	152									
ZX 7RR	750	96	98	KA-23	152									
ZXR HI-H2	750	89	90	KA-19	151									
ZXR J1-J2/L1-L3/P1-P7	750	91	03	KA-23	152									
ZXR R	750	91	94	KA-23	152									
VN A1-A3	800	95	99	KA-23	152									
VN B1-B10 CLASSIC	800	96	05	KA-23	152									
VN C1-C2/E1-E3 DRIFTER	800	99	04	KA-23	152									
Z 800	800	15												
Z 800	800	13												
Z 800 ABS	800	13												
Z 800 E	800	15												
GPZ R A1-A6	900	84	89	KA-23	152									
GPZ R A11	900	98		KA-23	152									
GPZ R A12-A15	900	99	02	KA-23	152									
GPZ R A7-A8	900	90	96	KA-23	152									
VN CUSTOM	900	07												
VN VULCAN CLASSIC	900	06												
Z A4-A5	900	76	77	KA-3	151									
ZX 9R B1-B2	900	94	95	KA-23	152									
ZX 9R B3-B4	900	96	97	KA-23	152									
ZX 9R C1-C2/E1-E2	900	98	01											
ZX 9R F1-F2	900	02	04											
ZX9 900 R NINJA	900	02												
GPZ RX	1000	86	89	KA-20	152									
GPZ RY	1000	86	89	KA-20	152									
GTR	1000	86	93	KA-20	152									
GTR	1000	94	03	KA-20	152									
Z	1000	03	06											
Z	1000	07	09											
Z 1000	1000	07												
Z 1000 ABS	1000	07												
Z 1000ZR	1000	03												
Z A1-A4-H1-H2	1000	77	81	KA-3	151									
Z E1-E2	1000	79	80	KA-20	152									

FRENI - BRAKES

VALVOLE - REEDS

COLLETTORI INTAKE MANIFOLDS

FERMACOPERTONI TIRE LOCKS

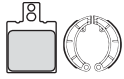

Pastiglie/Ganasce Anteriore
Front Brake Pads/Shoes

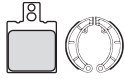

Pastiglie/Ganasce Posteriori
Rear Brake Pads/Shoes



Dischi Freno Anteriore
Front Brake Disk



Dischi Freno Posteriori
Rear Brake Disk



Lamelle
Reeds



Valvole Lamellari
Reed Valve



Valvola Power Reed
Power Reed Valve



Collettori Aspirazione
Intake Manifolds



Fermacopertoni Anteriore
Front Tire Locks



Fermacopertoni Posteriori
Rear Tire Locks

COD	PAG	COD	PAG	COD	PAG	COD	PAG	COD	PAG	COD	PAG	COD	PAG	COD	PAG	COD	PAG	COD	PAG
P.169	237	P.075	217																
P.190	246	P.114	225																
P.062	212	P.062	212																
P.062	212	P.062	212																
P.062	212																		
P.268	281	P.256	276																
P.232	264																		
P.232	264	P.134	228																
P.171	238	P.219	259																
P.169	237	P.219	259																
P.171	238																		
P.169	237	P.171	238																
P.161	234																		
P.107	224																		
P.107	224																		
P.107	224																		
P.062	212																		
P.169	237																		
P.169	237	P.171	238																
		P.256	276																
P.234	265	P.256	276																
		P.256	276																
		P.256	276																
		P.256	276																
P.062	212	P.062	212																
P.107	224																		
P.161	234																		
P.107	224																		
P.169	237	P.171	238																
P.169	237	P.171	238																
P.107	224																		
P.161	234	P.219	259																
P.161	234	P.219	259																
		P.219	259																
P.234	265																		
P.062	212	P.062	212																
P.062	212	P.062	212																
P.062	212	P.062	212																
		P.062	212																
P.234	265	P.219	259																
P.232	264																		
P.268	281																		
P.268	281																		
P.234	265																		

MARCA - MODELLO MAKE - MODEL



Serie
Dischi Rivestiti
Friction Plate Kit



RACING
Serie
Dischi Rivestiti
Friction Plate Kit



Serie Completa
Dischi Frizione
Clutch Plates
Complete Set



RACING
Serie Completa
Dischi Frizione
Clutch Plates
Complete Set



Frizione
Antisaltemento
Slipper Clutches



Carter Frizione
Clutch Covers

KAWASAKI	CC	MY	COD	PAG	COD	PAG	COD	PAG	COD	PAG	COD	PAG	COD	PAG
Z K1-J1-J3	1000	81	83	KA-20	152									
Z R2	1000	83		KA-20	152									
ZL A1-A2	1000	87	88	KA-20	152									
ZX 10R	1000	04	05											
ZX 10R	1000	06												
ZX B1-B2-B3	1000	88	91	KA-20	152									
GPZ A1-A3	1100	83	88	KA-20	152									
GPZ B1-B2	1100	81	82	KA-20	152									
GPZ S	1100	95												
Z A1-A3	1100	81	83	KA-20	152									
Z R1	1100	84	86	KA-20	152									
ZR A1-A2-A3-A4-B1	1100	93	95	KA-20	152									
ZR ZEPHYR A1-A4	1100	92	95	KA-20	152									
ZR ZEPHYR B1 PINZA SINISTRA	1100	96	98	KA-20	152									
ZR ZEPHYR B5 PINZA SINISTRA	1100	02		KA-20	152									
ZRX	1100	97	00	KA-20	152									
ZX D1-D5 ZX-11	1100	93	07											
ZZR	1100	90	92											
ZZR	1100	93	01											
ZG	1200	86	90											
ZRX	1200	01	05											
ZX 12R	1200	00	03											
ZX 12R	1200	04	05											
ZX 12R 1200 NINJA	1200	04												
ZXR R	1200	01	05											
ZXR S	1200	01	04											
ZZR C1H-C2H	1200	02	04											
Z A4-A5	1300	82	83	KA-34	153									
GTR	1400	07												
GTR 1400	1400	07												
GTR GRAND TOUR	1400	10												
ZG CONCOURS	1400	08												
ZG CONCOURS ABS	1400	08												
ZX 14R	1400	06												
ZZR	1400	06												
ZZR 1400 A6F	1400	06												
ZZR 1400 ABS B6F	1400	06												
VN 15 SE	1500	93												
VN CLASSIC	1500	96												
VN CLASSIC TOURER PINZA SIN.	1500	98	02											
VN DRIFTER	1500	02												
VN MEAN STREAK	1500	01	03											
VN SUMO	1500	94	96											
VN TOURER PINZA DES.	1500	03												
VN TOURER PINZA SIN.	1500	03												
VN VULCAN A1	1500	87												
VN 1600 MEAN STREAK	1600	05												
VN MEAN STREAK	1600	04												
VN SUMO CLASSIC PINZA SIN.	1600	03												
VN A VULCAN	2000	04												
KAWASAKI ATV	CC	MY												
KXT 250 TECATE A1	250	84												
KEEWAY	CC	MY												
50 HURRICANE	50	06												
HURRICANE	50	06												
90 HURRICANE	90	06												
125 SUPERLIGHT	125	06												
150 SUPERLIGHT	150	06												
250 LAND CRUISER	250	06												

FRENI - BRAKES

VALVOLE - REEDS

COLLETTORI INTAKE MANIFOLDS

FERMACOPERTONI TIRE LOCKS

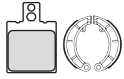

Pastiglie/Ganasce Anteriori
Front Brake Pads/Shoes

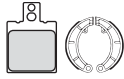

Pastiglie/Ganasce Posteriori
Rear Brake Pads/Shoes



Dischi Freno Anteriore
Front Brake Disk



Dischi Freno Posteriori
Rear Brake Disk



Lamelle
Reeds



Valvole Lamellari
Reed Valve



Valvola Power Reed
Power Reed Valve



Collettori Aspirazione
Intake Manifolds



Fermacopertoni Anteriore
Front Tire Locks



Fermacopertoni Posteriori
Rear Tire Locks

COD	PAG	COD	PAG	COD	PAG	COD	PAG	COD	PAG	COD	PAG	COD	PAG	COD	PAG	COD	PAG	COD	PAG
P.062	212	P.062	212																
		P.219	259																
		P.219	259																
P.062	212	P.062	212																
P.108	224	P.111	225																
P.107	224																		
P.107	224																		
P.169	237																		
P.171	238																		
P.161	234	P.111	225																
P.107	224	P.111	225																
P.107	224																		
P.107	224	P.111	225																
P.062	212	P.062	212																
P.161	234	P.111	225																
P.161	234	P.111	225																
		P.111	225																
P.232	264																		
P.161	234	P.111	225																
P.161	234																		
P.107	224	P.111	225																
P.232	264	P.218	259																
P.268	281																		
P.232	264	P.218	259																
P.232	264	P.218	259																
P.232	264	P.218	259																
P.232	264	P.218	259																
P.232	264	P.218	259																
P.268	281																		
P.268	281																		
P.062	212	P.062	212																
P.169	237	P.062	212																
P.171	238																		
P.169	237	P.171	238																
P.161	234	P.171	238																
P.062	212	P.062	212																
P.171	238																		
P.169	237	P.171	238																
P.062	212	P.062	212																
P.232	264																		
P.161	234	P.171	238																
P.169	237	P.062	212																
P.107	224	P.171	238																
		P.260	277																
P.260	277																		
P.030	210																		
P.260	277																		
P.259	277																		
P.259	277																		
P.259	277																		

MARCA - MODELLO MAKE - MODEL



Serie
Dischi Rivestiti
Friction Plate Kit



RACING
Serie
Dischi Rivestiti
Friction Plate Kit



Serie Completa
Dischi Frizione
Clutch Plates
Complete Set



RACING
Serie Completa
Dischi Frizione
Clutch Plates
Complete Set



Frizione
Antisaltemamento
Slipper Clutches



Carter Frizione
Clutch Covers

KREIDLER	CC	MY	COD	PAG	COD	PAG	COD	PAG	COD	PAG	COD	PAG	COD	PAG
ENDURO 125	125	07												
SUPERMOTO 125	125	07												
KTM	CC	MY												
EXC	50	99												
MX	50	85												
MX	50	86												
SX	60	99												
SX	65	00	01											
MX	80	92	01											
PL-WATERCOOLED-MX	80	86												
RLW-MX	80	80												
DUKE 125	125	11												
ENDURO	125	88	91											
ENDURO	125	92												
ENDURO	125	93												
EXC	125	03						KT-66	187					
EXC	125	04	06					KT-66	187					
EXC	125	07												
EXC-EGS-SX	125	95	97							KT-36/C	186			
EXC-EGS-SX	125	98	03					KT-66	187					
EXE	125	00						KT-66	187					
GS	125	89	90							KT-36/C	186			
GS	125	91	92							KT-36/C	186			
GS	125	93								KT-36/C	186			
GS	125	94	97							KT-36/C	186			
LC 2	125	98	00					FB-139	177					
MX	125	86	87							KT-36/C	186			
MX	125	88								KT-36/C	186			
MX	125	89	91							KT-36/C	186			
MX	125	92								KT-36/C	186			
MX SUPERMOTO	125	00												
RS	125	89								KT-36/C	186			
SX	125	93								KT-36/C	186			
SX	125	94	97							KT-36/C	186			
SX	125	04						KT-66	187					
SX	125	98	03					KT-66	187					
VC	125	87								KT-36/C	186			
WMX	125	88								KT-36/C	186			
XC	125	86								KT-36/C	186			
EGS	200	99	02					KT-66	187					
EXC	200	98	02					KT-66	187					
EXC	200	03						KT-66	187					
EXC	200	04	06					KT-66	187					
EXC	200	07												
SX	200	03						KT-66	187					
SX	200	04						KT-66	187					
ENDURO	250	88	91											
ENDURO	250	92		KT-56	154									
ENDURO	250	93		KT-56	154									
EXC	250	03		KT-56	154									
EXC SIX DAYS	250	10		KT-56	154									
EXC-EGS-SX	250	93	95	KT-56	154									
EXC-EGS-SX	250	96	02											
EXC-EGS-SX	250	96	11	KT-56	154									
GS	250	88												
GS	250	89	90	KT-49	154									
GS	250	91	92	KT-56	154									
GS	250	93		KT-56	154									
GS	250	94		KT-56	154									
MX	250	88												

FRENI - BRAKES

VALVOLE - REEDS

COLLETTORI INTAKE MANIFOLDS

FERMACOPERTONI TIRE LOCKS

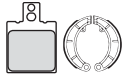

Pastiglie/Ganasce Anteriori
Front Brake Pads/Shoes

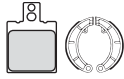

Pastiglie/Ganasce Posteriori
Rear Brake Pads/Shoes



Dischi Freno Anteriori
Front Brake Disk



Dischi Freno Posteriori
Rear Brake Disk



Lamelle
Reeds



Valvole Lamellari
Reed Valve



Valvola Power Reed
Power Reed Valve



Collettori Aspirazione
Intake Manifolds



Fermacopertoni Anteriori
Front Tire Locks



Fermacopertoni Posteriori
Rear Tire Locks

COD	PAG	COD	PAG	COD	PAG	COD	PAG	COD	PAG	COD	PAG	COD	PAG	COD	PAG	COD	PAG	COD	PAG
P.259	277																		
P.259	277																		
P.133	227	P.065	213																
P.012	208							27	312										
								19	311										
P.065	213																		
P.065	213																		
P.012	208							08	310										
P.012	208	P.012	208																
P.012	208	P.012	208																
P.255	276																		
P.074	216	P.074	216																
		P.075	217																
P.143	230	P.075	217																
P.143	230	P.203	252																
P.143	230	P.203	252																
P.143	230	P.203	252																
P.143	230	P.172	238																
P.143	230	P.172	238																
P.143	230	P.172	238																
P.074	216	P.074	216					61	313	KT-59	320	PWR-2	323			MA-139	332	MA-152	333
		P.075	217					61	313	KT-59	320	PWR-2	323			MA-139	332	MA-152	333
P.143	230	P.075	217					61	313	KT-59	320	PWR-2	323			MA-139	332	MA-152	333
P.143	230	P.172	238					61	313	KT-59	320	PWR-2	323			MA-139	332	MA-152	333
P.143	230	P.172	238																
P.012	208							61	313	KT-59	320	PWR-2	323			MA-139	332	MA-152	333
P.074	216	P.074	216					61	313	KT-59	320	PWR-2	323			MA-139	332	MA-152	333
P.075	217	P.075	217					61	313	KT-59	320	PWR-2	323			MA-139	332	MA-152	333
P.143	230	P.075	217					61	313	KT-59	320	PWR-2	323			MA-139	332	MA-152	333
P.143	230	P.172	238																
P.082	219																		
P.143	230	P.075	217																
P.143	230	P.172	238																
P.143	230	P.203	252																
P.143	230	P.203	252																
P.143	230	P.203	252																
P.143	230	P.203	252																
P.143	230	P.203	252																
P.143	230	P.203	252																
P.074	216	P.074	216																
		P.075	217																
P.143	230	P.075	217																
P.143	230	P.203	252																
P.143	230	P.075	217					61	313	KT-59	320	PWR-2	323			MA-139	332	MA-152	333
P.143	230	P.172	238					61	313	KT-59	320	PWR-2	323			MA-139	332	MA-152	333
P.074	216	P.074	216																
P.074	216	P.074	216					61	313	KT-59	320	PWR-2	323			MA-139	332	MA-152	333
		P.075	217					61	313	KT-59	320	PWR-2	323			MA-139	332	MA-152	333
P.143	230	P.075	217					61	313	KT-59	320	PWR-2	323			MA-139	332	MA-152	333
P.143	230	P.172	238					61	313	KT-59	320	PWR-2	323			MA-139	332	MA-152	333
P.075	217	P.075	217					61	313	KT-59	320	PWR-2	323			MA-139	332	MA-152	333

MARCA - MODELLO MAKE - MODEL



Serie
Dischi Rivestiti
Friction Plate Kit



RACING
Serie
Dischi Rivestiti
Friction Plate Kit



Serie Completa
Dischi Frizione
Clutch Plates
Complete Set



RACING
Serie Completa
Dischi Frizione
Clutch Plates
Complete Set



Frizione
Antisaltemento
Slipper Clutches



Carter Frizione
Clutch Covers

KTM	CC	MY	COD	PAG	COD	PAG	COD	PAG	COD	PAG	COD	PAG	COD	PAG
MX	250	89	KT-49	154										
MX	250	90	02	KT-56	154									
MX	250	03												
SX	250	03												
SX-EGS-EXC	250	93	95	KT-56	154									
SX-EGS-EXC	250	96	02	KT-56	154									
SX-F	250	05	08	HO-182	149			HO-183	183	HO-183/C	184			
WMX	250	88												
XC-F	250	06	08	HO-182	149			HO-183	183	HO-183/C	184			
XC-F-W	250	06	08	HO-182	149			HO-183	183	HO-183/C	184			
ENDURO	300	92		KT-56	154									
ENDURO	300	93		KT-56	154									
EXC	300	03		KT-56	154									
GS	300	91		KT-56	154									
GS-XC	300	86												
SX-EGS-EXC	300	93		KT-56	154									
ENDURO	350	88												
GS 4-K 4-XC-MC	350	83												
LC 4 EXC	350	94		KT-56	154									
MX	350	87	88											
MX	350	89	91											
MX	350	92		KT-56	154									
WMX	350	88												
DUKE 390	390	13												
XC-MC	390	83												
EXC RACING	400	04	05											
EXC RACING	400	06												
LC 4 EGS	400	94						KT-64	187					
XC-MC	420	83												
EXC R	450	08											KT-76	203
EXC RACING	450	03												
EXC RACING	450	04	05											
EXC RACING	450	06												
SMR	450	08											KT-74	203
SX	450	94	02											
SX RACING	450	03												
SX RACING	450	04	05											
SX RACING	450	06												
SX-F	450	08											KT-74	203
GS	500	89												
K 4	500	83												
MX	500	86												
MX	500	87												
MX	500	88												
MX	500	89	91											
MX	500	92						KT-64	187					
SX	500	93						KT-64	187					
SX-F	500	08											KT-74	203
WMX	500	88												
XC-MC	500	83												
EXC RACING	525	03												
EXC RACING	525	04	05											
EXC RACING	525	06												
SMR	525	05												
SX RACING	525	03												
SX RACING	525	04	05											
SX RACING	525	06												
EXC R	530	08											KT-76	203
SXC	540	99												
MG-SX	550	94												

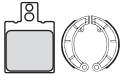
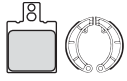
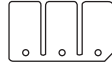
FRENI - BRAKES**VALVOLE - REEDS****COLLETTORI
INTAKE
MANIFOLDS****FERMACOPERTONI
TIRE LOCKS****Pastiglie/Ganasce
Anteriore**
Front Brake
Pads/Shoes**Pastiglie/Ganasce
Posteriore**
Rear Brake
Pads/Shoes**Dischi Freno
Anteriore**
Front Brake Disk**Dischi Freno
Posteriore**
Rear Brake Disk**Lamelle**
Reeds**Valvole Lamellari**
Reed Valve**Valvola Power Reed**
Power Reed Valve**Collettori
Aspirazione**
Intake Manifolds**Fermacopertoni
Anteriore**
Front Tire Locks**Fermacopertoni
Posteriore**
Rear Tire Locks

COD	PAG	COD	PAG	COD	PAG	COD	PAG	COD	PAG	COD	PAG	COD	PAG	COD	PAG	COD	PAG	COD	PAG
P.143	230	P.075	217			61	313	KT-59	320	PWR-2	323			MA-139	332	MA-152	333		
P.143	230					61	313	KT-59	320	PWR-2	323			MA-139	332	MA-152	333		
P.143	230	P.203	252																
P.143	230	P.203	252																
P.143	230	P.075	217			61	313	KT-59	320	PWR-2	323			MA-139	332	MA-152	333		
P.143	230	P.172	238			61	313	KT-59	320	PWR-2	323			MA-139	332	MA-152	333		
P.143	230	P.203	252																
P.085	219	P.085	219																
P.143	230	P.203	252																
P.143	230	P.203	252																
		P.075	217													MA-140	333	MA-153	334
P.143	230	P.075	217													MA-140	333	MA-153	334
P.143	230	P.203	252																
		P.075	217																
P.012	208	P.012	208																
P.143	230	P.075	217																
P.074	216	P.074	216																
P.012	208																		
P.143	230	P.172	238																
P.085	219	P.085	219													MA-139	332	MA-153	334
		P.075	217													MA-139	332	MA-153	334
P.143	230	P.075	217													MA-139	332	MA-153	334
P.085	219	P.085	219													MA-139	332	MA-153	334
P.255	276																		
P.012	208																		
P.143	230	P.203	252																
P.143	230	P.203	252																
P.143	230	P.172	238																
P.012	208																		
P.143	230	P.172	238																
P.143	230	P.203	252																
P.143	230	P.203	252																
P.143	230	P.172	238																
P.143	230	P.172	238																
P.143	230	P.203	252																
P.143	230	P.203	252																
P.143	230	P.172	238																
P.143	230	P.172	238																

MARCA - MODELLO MAKE - MODEL



Serie
Dischi Rivestiti
Friction Plate Kit



RACING
Serie
Dischi Rivestiti
Friction Plate Kit



Serie Completa
Dischi Frizione
Clutch Plates
Complete Set



RACING
Serie Completa
Dischi Frizione
Clutch Plates
Complete Set



Frizione
Antisaltemento
Slipper Clutches



Carter Frizione
Clutch Covers

KTM	CC	MY	COD	PAG	COD	PAG	COD	PAG	COD	PAG	COD	PAG	COD	PAG
XC	550	86												
SMR	560	08											KT-74	203
SMR	560	06												
4T GARA	600	91												
4T GS	600	93												
4T GS	600	94												
4T-GS-A-E	600	87												
BAJA	600	87												
DUKE	600	93	95											
ENDURO LC 4-INCAS	600	88												
ER LCH	600	88												
MC LC 4	600	90												
DUKE	620	95	98					KT-63	186					
DUKE II	620	99	02					KT-63	186					
LC 4 EXC-EGS-SX	620	94	02					KT-63	186					
LC4 SXC SUPERMOTO	620	98	02					KT-63	186					
SC	620	99						KT-63	186					
EXC	625	03						KT-63	186					
LC4 SUPERCOMPETITION	625	02						KT-63	186					
DUKE	640	99						KT-63	186					
DUKE	640	99	02											
DUKE	640	03	06											
LC 4 ADVENTURE R	640	98						KT-63	186					
LC 4 ENDURO	640	99						KT-63	186					
LC 4 SUPERMOTO	640	99	02					KT-63	186					
LC 4 SUPERMOTO	640	03						KT-63	186					
LC 4 SMC SUPERMOTO	660	03						KT-63	186					
DUKE	690	08												
DUKE R	690	10												
SM	690	07												
SMC	690	08												
ADVENTURE S	950	03												
ADVENTURE S	950	04	06											
DUKE	950	03												
SM	950	05	07											
SM R	950	05	07											
SMC	950	05												
ADVENTURE S	990	06												
DUKE	990	04												
SUPERDUKE	990	05												
SUPERDUKE R	990	09	10											
R RC8 R	1190	09												
R RC8 R TRACK	1190	09												
RC8	1190	08												
KYMC0	CC	MY												
AGILITY	50	05												
BET & WIN	50	01												
COBRA CROSS	50	05												
DJX	50	94												
DJY	50	94												
EASY	50	01												
FEVER ZX	50	97												
FILLY 50 LX	50	02												
HEROISM	50	95												
JAGER	50	01												
K 12	50	95												
K B	50	95												
LIKE 2T	50	09												
LIKE 4T	50	09												
PEOPLE	50	99	02											

FRENI - BRAKES

VALVOLE - REEDS

COLLETTORI INTAKE MANIFOLDS

FERMACOPERTONI TIRE LOCKS

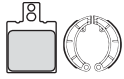

Pastiglie/Ganasce Anteriori
Front Brake Pads/Shoes

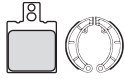

Pastiglie/Ganasce Posteriori
Rear Brake Pads/Shoes



Dischi Freno Anteriori
Front Brake Disk



Dischi Freno Posteriori
Rear Brake Disk



Lamelle
Reeds



Valvole Lamellari
Reed Valve



Valvola Power Reed
Power Reed Valve



Collettori Aspirazione
Intake Manifolds



Fermacopertoni Anteriori
Front Tire Locks



Fermacopertoni Posteriori
Rear Tire Locks

COD	PAG	COD	PAG	COD	PAG	COD	PAG	COD	PAG	COD	PAG	COD	PAG	COD	PAG	COD	PAG	COD	PAG
P.012	208	P.012	208																
		P.203	252																
		P.075	217																
P.143	230	P.075	217																
P.143	230	P.172	238																
P.012	208																		
P.085	219	P.085	219																
P.067	214																		
P.074	216	P.074	216																
P.085	219	P.085	219																
P.075	217	P.075	217																
P.067	214	P.172	238																
P.143	230	P.172	238																
P.143	230	P.172	238																
P.143	230	P.172	238																
P.143	230	P.172	238																
P.143	230	P.203	252																
P.143	230	P.172	238																
P.067	214	P.012	208																
P.168	236	P.172	238																
P.143	230	P.172	238																
P.143	230	P.172	238																
P.143	230	P.172	238																
P.143	230	P.172	238																
P.143	230	P.172	238																
P.143	230	P.172	238																
P.143	230	P.172	238																
P.211	256	P.172	238																
P.211	256	P.172	238																
P.211	256	P.172	238																
P.211	256																		
P.143	230																		
P.192	247	P.143	230																
P.211	256	P.172	238																
P.211	256	P.143	230																
P.211	256	P.143	230																
P.211	256	P.143	230																
P.211	256	P.143	230																
P.192	247	P.143	230																
P.211	256	P.172	238																
P.211	256	P.172	238																
P.211	256	P.172	238																
P.229	262	P.186	244																
P.229	262	P.186	244																
P.229	262	P.186	244																
P.210	256			DF-15	298														
P.166	235	P.166	235	DF-27	302														
P.093	221			DF-4	293			83	314					VE-371	329				
								83	314					VE-371	329				
P.093	221			DF-4	293			83	314					VE-371	329				
P.259	277			DF-4	293			83	314					VE-371	329				
P.166	235	01200	288	DF-4	293			83	314					VE-371	329				
				DF-4	293			83	314					VE-371	329				
				DF-4	293			83	314					VE-371	329				
P.210	256																		
P.210	256																		
								83	314					VE-371	329				

MARCA - MODELLO MAKE - MODEL



Serie
Dischi Rivestiti
Friction Plate Kit



RACING
Serie
Dischi Rivestiti
Friction Plate Kit



Serie Completa
Dischi Frizione
Clutch Plates
Complete Set



RACING
Serie Completa
Dischi Frizione
Clutch Plates
Complete Set



Frizione
Antisaltemento
Slipper Clutches



Carter Frizione
Clutch Covers

KYMCO	CC	MY	COD	PAG	COD	PAG	COD	PAG	COD	PAG	COD	PAG	COD	PAG
PEOPLE S	50	05	08											
SCOUT	50	99												
SNIPER DD	50	94												
SUPER 8 2T	50	07												
SUPER 8 4T	50	07												
SUPER-9 L.C.	50	00												
TOP BOY	50	97												
VITALITY 50	50	04												
YAGER	50	07												
YUP	50	01												
YUP 50	50	02												
ZX	50	05												
TOP BOY	100	98												
AGILITY	125	06												
BET & WIN 4T	125	00												
DINK	125	97												
DINK LX	125	99												
DOWNTOWN 125 I	125	09												
GRAND DINK	125	02												
HEROISM	125	95												
JOYRIDE	125	01												
MOVIE	125	97												
MOVIE XL	125	01												
PEOPLE 125 EURO 3	125	07												
PEOPLE 4T	125	00												
PEOPLE GTI 125	125	10												
PEOPLE S 125 DD	125	07												
QUANNON	125	07												
STRYKER	125	99												
SUPER-9 L.C.	125	00												
SUPERDYNK 125	125	10												
VIVIO	125	01												
VIVIO 125	125	01												
YAGER GT	125	07												
DINK	150	97												
DINK LX	150	99												
GRAND DINK	150	02												
HEROISM	150	95												
JOYRIDE	150	01												
MOVIE	150	97												
MOVIE XL	150	99												
PEOPLE 4T	150	99												
SUPER 8	150	07												
VIVIO	150	99												
VIVIO 150	150	01												
DOWNTOWN 200 I	200	10												
PEOPLE 4T	200	05												
PEOPLE GTI 200	200	10												
PEOPLE S 200 I	200	07												
BET & WIN 4T	250	00												
DINK	250	00												
GRAND DINK	250	02												
GRANDVISTA	250	08												
PEOPLE 4T	250	02	05											
PEOPLE 4T	250	06												
PEOPLE S 250 Ipinza sx	250	07												
PEOPLE S 250pinza sx	250	06												
XCITING 250	250	05												
XCITING 250 i	250	06												
YUP	250	02												

FRENI - BRAKES

VALVOLE - REEDS

COLLETTORI INTAKE MANIFOLDS

FERMACOPERTONI TIRE LOCKS

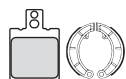

Pastiglie/Ganasce Anteriori
Front Brake Pads/Shoes

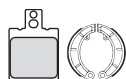

Pastiglie/Ganasce Posteriori
Rear Brake Pads/Shoes



Dischi Freno Anteriore
Front Brake Disk



Dischi Freno Posteriori
Rear Brake Disk



Lamelle
Reeds



Valvole Lamellari
Reed Valve



Valvola Power Reed
Power Reed Valve



Collettori Aspirazione
Intake Manifolds



Fermacopertoni Anteriore
Front Tire Locks



Fermacopertoni Posteriori
Rear Tire Locks

COD	PAG	COD	PAG	COD	PAG	COD	PAG	COD	PAG	COD	PAG	COD	PAG	COD	PAG	COD	PAG	COD	PAG
P.210	256																		
P.093	221							83	314					VE-371	329				
				DF-4	293			83	314					VE-371	329				
P.210	256																		
P.210	256	P.210	256					83	314					VE-371	329				
				DF-15	298			83	314					VE-371	329				
P.259	277																		
P.166	235																		
P.086	220			DF-15	298														
P.259	277																		
P.093	221			DF-4	293			83	314					VE-371	329				
								83	314					VE-371	329				
P.210	256																		
P.166	235	P.166	235																
P.166	235	P.166	235	DF-15	298	DF-15	298												
P.166	235	P.166	235	DF-15	298	DF-15	298												
		P.265	280																
P.166	235	P.166	235			DF-28	302												
				DF-4	293														
		P.166	235																
P.086	220																		
P.166	235																		
		P.264	280																
P.210	256																		
		P.265	280																
		P.264	280																
P.166	235	P.166	235																
P.166	235																		
P.093	221	P.210	256																
		P.265	280																
P.086	220																		
P.259	277																		
P.166	235	P.166	235																
P.166	235	P.166	235	DF-15	298	DF-15	298												
				DF-15	298	DF-15	298												
P.166	235	P.166	235																
				DF-4	293														
		P.166	235																
P.086	220																		
P.166	235			DF-27	302														
P.210	256																		
P.210	256																		
P.086	220																		
P.259	277																		
		P.265	280																
P.210	256																		
		P.265	280																
		P.264	280																
P.166	235	P.166	235	DF-27	302	DF-28	302												
P.166	235	P.166	235																
P.195	248	P.196	249	DF-27	302	DF-28	302												
P.166	235	P.166	235	DF-27	302	DF-28	302												
P.166	235																		
P.166	235																		
P.259	277	P.264	280																
P.259	277	P.264	280																
P.108	224	P.264	280	DF-38	306														
		P.264	280																
P.166	235					DF-28	302												

MARCA - MODELLO MAKE - MODEL



Serie
Dischi Rivestiti
Friction Plate Kit



RACING
Serie
Dischi Rivestiti
Friction Plate Kit



Serie Completa
Dischi Frizione
Clutch Plates
Complete Set



RACING
Serie Completa
Dischi Frizione
Clutch Plates
Complete Set



Frizione
Antisaltemento
Slipper Clutches



Carter Frizione
Clutch Covers

KYMCO	CC	MY	COD	PAG	COD	PAG	COD	PAG	COD	PAG	COD	PAG	COD	PAG
DOWNTOWN 300 I	300	09												
PEOPLE GTI 300	300	10												
PEOPLE S 300 Ipinza sx	300	08												
XCITING	300	08												
XCITING 300 I R	300	08												
XCITING 400 I	400	12												
XCITING 500	500	05												
XCITING 500 I	500	06												
XCITING 500 I R	500	07												
MY ROAD 700	700	09												
KYMCO ATV	CC	MY												
KXR 250	250	03												
MXU 250	250	05												
LAVERDA	CC	MY												
GAUCHO	50	90	FB-116	141					FB-123/C	177				
OR ATLAS	50	86	FB-104	141										
OR ATLAS	50	89	FB-116	141					FB-123/C	177				
OR ATLAS ADVENTURE	50	88	FB-116	141					FB-123/C	177				
125	125													
NAVARRO	125	90	MA-174	156			MA-175	189	MA-175/C	189				
PHOENIX 125	125	01												
TOLEDO	125	90	MA-174	156			MA-175	189	MA-175/C	189				
PHOENIX 150	150	01												
PHOENIX 200	200	01												
GS LESMO	350	86												
RS-RF-ALPINO	350	77												
RS-RF-ALPINO-MONTJUICH	500	77												
SFC 500	500	77												
668	650	92					LV-35	187						
HIDALGO	668	90					LV-35	187						
EL CID	700	90					LV-35	187						
BLACK STRIKE	750	00					LV-35	187						
FORMULA	750	00					LV-35	187						
SF3 750	750	77												
SUPER SPORT	750	00					LV-35	187						
3CE 1000	1000	74												
JOTA 1000	1000	95												
RGS 1000	1000	83												
RGS 1000 CORSA	1000													
RGS 1000 JOTA	1000	77												
RGS 1000 JOTA	1000	86												
SFC	1000	03												
SFC 1000	1000	85												
TGA 1000 EXECUTIVE	1000	84												
MIRAGE 1200	1200	78												
T.T. 1200	1200	76												
MAICO	CC	MY												
C 1 50 HARD ENDURO	50	99												
R 1 50 SUPERBIKE	50	99												
THUNDERBIKE 50 I	50	99												
X 1 50 SUPERCROSS	50	99												
ENDURO	250	99												
MOTOCROSS	250	99												
ENDURO	500	99												
MOTOCROSS	500	99												
SUPERMOTARD	500	99												
MALAGUTI	CC	MY												
CENTRO 50 4T	50	08												
CENTRO SL	50	94												
CENTRO SL 50 4T	50	10												

FRENI - BRAKES

VALVOLE - REEDS

COLLETTORI INTAKE MANIFOLDS

FERMACOPERTONI TIRE LOCKS

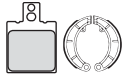

Pastiglie/Ganasce Anteriori
Front Brake Pads/Shoes

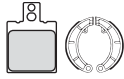

Pastiglie/Ganasce Posteriori
Rear Brake Pads/Shoes



Dischi Freno Anteriore
Front Brake Disk



Dischi Freno Posteriori
Rear Brake Disk



Lamelle
Reeds



Valvole Lamellari
Reed Valve



Valvola Power Reed
Power Reed Valve



Collettori Aspirazione
Intake Manifolds



Fermacopertoni Anteriore
Front Tire Locks



Fermacopertoni Posteriori
Rear Tire Locks

COD	PAG	COD	PAG	COD	PAG	COD	PAG	COD	PAG	COD	PAG	COD	PAG	COD	PAG	COD	PAG	COD	PAG
		P.265	280																
		P.265	280																
P.259	277	P.264	280																
P.156	232	P.156	232																
		P.264	280																
P.262	279	P.244	270																
P.108	224	P.244	270	DF-38	306	DF-39	306												
		P.244	270																
		P.244	270																
		P.244	270																
		P.244	270																
P.240	268																		
P.240	268																		
P.012	208	P.012	208																
P.012	208	P.012	208																
P.012	208	P.012	208																
P.012	208	P.012	208																
P.245	270																		
														PWR-1	322				
P.250	273													PWR-1	322				
P.250	273																		
P.250	273																		
		P.012	208																
P.012	208	P.012	208																
P.012	208	P.012	208																
P.245	270	P.245	270																
P.067	214	P.012	208																
P.075	217	P.075	217																
P.075	217	P.075	217																
P.067	214	P.012	208																
P.067	214	P.012	208																
P.245	270	P.245	270																
P.067	214	P.012	208																
P.245	270	P.245	270																
		P.245	270																
P.245	270	P.245	270																
P.245	270	P.245	270																
P.245	270	P.245	270																
P.211	256	P.186	244																
P.245	270	P.245	270																
P.245	270	P.245	270																
P.245	270	P.245	270																
P.245	270	P.245	270																
		P.245	270																
P.260	277																		
P.260	277																		
P.260	277																		
P.260	277																		
P.143	230	P.172	238																
P.143	230	P.172	238																
P.143	230	P.172	238																
P.143	230	P.172	238																
P.143	230	P.172	238																
P.260	277																		
P.098	222	01200	288	DF-10	296			98	315	FB-146	319			FB-135	328				
P.260	277																		

MARCA - MODELLO MAKE - MODEL



MALAGUTI	CC	MY	COD	PAG	COD	PAG	COD	PAG	COD	PAG	COD	PAG	COD	PAG
CIAK	50	99												
CROSSER	50	99												
DRAKON	50	06	FB-132	142	FB-132/M	142	FB-140	178	FB-140/C	178				
DRIBBLING	50	85					BT-40	170						
DRIBBLING PEDALI	50	85					BT-40	170						
DUNE ES-KS	50	89	FB-116	141					FB-123/C	177				
F 10	50	92												
F 10	50	96												
F 10 50 AC ECO	50	09												
F 12 PHANTHOM	50	94												
F 12 PHANTHOM	50	98												
F 12 PHANTHOM	50	99												
F 12 R 50 PHANTOM AC	50	09												
F 12 R 50 PHANTOM LC	50	07												
F 15 FIREFOX	50	97												
F 15 FIREFOX L.C.	50	99												
FIFTY	50	89							MF-25/C	189				
FIFTY FULL CX	50	86							MF-25/C	189				
FIFTY TOP	50	89							MF-25/C	189				
GRIZZLY	50	87					BT-40	170						
MDX	50	86												
MEX	50	86	FB-116	141					FB-123/C	177				
MFX	50	86												
MGX	50	87												
MRX	50	89	FB-116	141					FB-123/C	177				
RST	50	90	FB-116	141					FB-123/C	177				
XSM SUPERMOTARD	50	03	FB-132	142	FB-132/M	142	FB-140	178	FB-140/C	178				
XTM	50	03	FB-132	142	FB-132/M	142	FB-140	178	FB-140/C	178				
YESTERDAY	50	98												
CIAK	100	00												
F 12 PHANTHOM	100	00												
BLOG 125 IE	125	09												
CENTRO 125 IE	125	08												
CENTRO 125 SL IE	125	09												
CENTRO IE SL	125	09	10											
CIAK	125	01	02											
CIAK	125	03												
F 12 PHANTHOM MAX	125	04												
F 18 WARRIOR	125	00	03											
MADISON	125	99												
MADISON 3 125	125	06												
MADISON R	125	06												
CIAK	150	01	02											
CIAK	150	03												
F 18 WARRIOR	150	00	03											
MADISON	150	99												
BLOG 160 IE	160	09												
CENTRO 160 IE	160	08												
CENTRO 160 SL IE	160	09												
CENTRO IE SL	160	09	10											
MADISON	180	01												
MADISON S	200	04												
MADISON	250	99	00											
MADISON	250	01	04											
MADISON 3 250	250	06												
MADISON RS	250	05												
PASSWORD	250	05												
MADISON	400	02	04											
MADISON K	400	05												
SPIDERMAX GT	500	04												

FRENI - BRAKES

VALVOLE - REEDS

COLLETTORI INTAKE MANIFOLDS

FERMACOPERTONI TIRE LOCKS

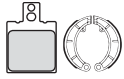

Pastiglie/Ganasce Anteriori
Front Brake Pads/Shoes

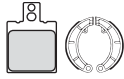

Pastiglie/Ganasce Posteriori
Rear Brake Pads/Shoes



Dischi Freno Anteriori
Front Brake Disk



Dischi Freno Posteriori
Rear Brake Disk



Lamelle
Reeds



Valvole Lamellari
Reed Valve



Valvola Power Reed
Power Reed Valve



Collettori Aspirazione
Intake Manifolds



Fermacopertoni Anteriori
Front Tire Locks



Fermacopertoni Posteriori
Rear Tire Locks

COD	PAG	COD	PAG	COD	PAG	COD	PAG	COD	PAG	COD	PAG	COD	PAG	COD	PAG	COD	PAG	COD	PAG
P.139	228	01200	288					98	315	FB-146	319			FB-135	328				
P.071	215			DF-8	295			90	314					FB-135	328				
		P.071	215					29	312										
		01200	288	DF-6	294			98	315	FB-146	319			FB-135	328				
P.139	228	01200	288	DF-6	294			98	315	FB-146	319			FB-135	328				
P.260	277																		
P.071	215			DF-8	295			98	315	FB-146	319			FB-135	328				
P.098	222			DF-8	295			98	315	FB-146	319			FB-135	328				
P.098	222	P.139	228	DF-20	300	DF-8	295	98	315	FB-146	319			FB-135	328				
P.260	277																		
P.260	277																		
		01200	288	DF-8	295			98	315	FB-146	319			FB-135	328				
P.098	222	P.144	231	DF-20	300	DF-8	295	98	315	FB-146	319			FB-135	328				
P.071	215							24	312										
P.071	215							24	312										
P.071	215							24	312										
										MF-84	321								
P.012	208																		
P.075	217																		
P.075	217																		
P.071	215																		
								29	312										
								29	312										
P.158	233	P.065	213																
P.139	228	01200	288					98	315	FB-146	319			FB-135	328				
P.139	228	01200	288																
P.139	228	P.139	228	DF-20	300	DF-8	295	98	315	FB-146	319			FB-135	328				
P.259	277																		
P.259	277																		
P.259	277																		
P.204	253	P.079	218																
P.173	240																		
P.139	228	P.139	228																
P.158	233	P.184	243	DF-29	302	DF-29	302												
P.173	240	P.184	243			DF-8	295												
P.158	233	P.184	243																
		P.266	280																
P.074	216	P.184	243	DF-29	302	DF-29	302												
P.173	240																		
P.139	228	P.139	228																
P.173	240	P.184	243																
P.158	233	P.184	243	DF-29	302	DF-29	302												
P.259	277																		
P.259	277																		
P.259	277																		
P.204	253	P.079	218																
P.158	233	P.184	243	DF-29	302	DF-29	302												
P.158	233	P.184	243																
P.208	255	P.184	243			DF-29	302												
P.208	255	P.184	243			DF-29	302												
		P.266	280																
P.208	255	P.184	243			DF-29	302												
P.158	233	P.184	243																
P.208	255	P.184	243																
P.208	255	P.184	243																
P.208	255	P.184	243																
P.074	216	P.184	243																



Serie
Dischi Rivestiti
Friction Plate Kit



RACING
Serie
Dischi Rivestiti
Friction Plate Kit



Serie Completa
Dischi Frizione
Clutch Plates
Complete Set



RACING
Serie Completa
Dischi Frizione
Clutch Plates
Complete Set



Frizione
Antisaltemento
Slipper Clutches



Carter Frizione
Clutch Covers

MARCA - MODELLO MAKE - MODEL

MALANCA	CC	MY	COD	PAG	COD	PAG	COD	PAG	COD	PAG	COD	PAG	COD	PAG
E 2C	80	82												
E 2C-5 N-6 N	125	82												
GT I	125	83												
MARK	125	85												
SPORT	125	83												
MBK	CC	MY												
BOOSTER N.G.	50	95	98											
BOOSTER N.G.	50	99												
BOOSTER R	50	93	95											
BOOSTER SPIRIT	50	95	98											
BOOSTER SPIRIT	50	99												
BOOSTER TRACK	50	96												
FIZZ	50	94												
FLIPPER	50	99												
FORTE	50	94												
NEW SORRISO	50	99												
NITRO	50	97												
OVETTO	50	98												
SORRISO	50	92												
STUNT	50	00												
TARGET	50	92	94											
X-LIMIT	50	00		FB-132	142	FB-132/M	142	FB-140	178	FB-140/C	178			
BOOSTER	100	99												
BOOSTER	100	00												
NITRO	100	00												
OVETTO	100	00												
DOODO	125	99												
FLAME	125	96	99											
FLAME	125	00												
SKYLINER	125	99												
SKYLINER	125	02												
THUNDER	125	02												
DOODO	150	99												
DOODO	150	00												
SKYLINER	150	00												
THUNDER	150	01												
VERTEX	150	97												
SKYLINER	180	03												
SKYLINER	250	00												
SKYLINER	250	01												
KILIBRE	300	03												
SKYLINER	400	04												
METRAKIT	CC	MY												
PRE GP 125	125	07												
MINARELLI	CC	MY												
AM 345	50	91		FB-132	142	FB-132/M	142	FB-140	178	FB-140/C	178			
C4	50	89		FB-116	141					FB-123/C	177			
DL 3	50	89		FB-116	141					FB-123/C	177			
DL 4	50	89		FB-116	141					FB-123/C	177			
EZ V1	50	89						FB-14	176					
P 4	50	88		FB-116	141					FB-123/C	177			
P 4 (MOD. ADIGE)	50	88						FB-107	177					
P 4 SPECIAL	50	88		FB-22	140									
P 4 SPORT	50	88		FB-70	140									
P 6	50	88		FB-116	141					FB-123/C	177			
RV 3 (CILINDRO APRILIA)	50	89		FB-116	141					FB-123/C	177			
RV 3 (CILINDRO ORIGINALE)	50	89		FB-116	141					FB-123/C	177			
RV 4 (CILINDRO APRILIA)	50	89		FB-116	141					FB-123/C	177			
RV 4 (CILINDRO ORIGINALE)	50	89		FB-116	141					FB-123/C	177			
RV 6 (CILINDRO APRILIA)	50	89		FB-116	141					FB-123/C	177			

FRENI - BRAKES

VALVOLE - REEDS

COLLETTORI INTAKE MANIFOLDS

FERMACOPERTONI TIRE LOCKS

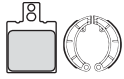

Pastiglie/Ganasce Anteriori
Front Brake Pads/Shoes

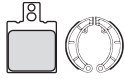

Pastiglie/Ganasce Posteriori
Rear Brake Pads/Shoes



Dischi Freno Anteriore
Front Brake Disk



Dischi Freno Posteriori
Rear Brake Disk



Lamelle
Reeds



Valvole Lamellari
Reed Valve



Valvola Power Reed
Power Reed Valve



Collettori Aspirazione
Intake Manifolds



Fermacopertoni Anteriore
Front Tire Locks



Fermacopertoni Posteriori
Rear Tire Locks

COD	PAG	COD	PAG	COD	PAG	COD	PAG	COD	PAG	COD	PAG	COD	PAG	COD	PAG	COD	PAG	COD	PAG
P.012	208	P.012	208																
P.012	208																		
P.012	208	P.012	208																
P.012	208																		
P.012	208	P.012	208																
P.173	240			DF-7	294			77	314					FB-134	327				
P.173	240			DF-5	293			77	314					FB-134	327				
P.173	240			DF-12	297			77	314					FB-134	327				
P.173	240			DF-12	297			77	314					FB-134	327				
P.173	240			DF-7	294			77	314					FB-134	327				
P.173	240							77	314					FB-134	327				
				DF-12	297			77	314					FB-134	327				
P.139	228							98	315	FB-146	319			FB-135	328				
P.173	240			DF-12	297			77	314					FB-134	327				
								98	315	FB-146	319			FB-135	328				
P.173	240	P.176	241	DF-5	293	DF-5	293	98	315	FB-146	319			FB-135	328				
P.173	240			DF-1	292			98	315	FB-146	319			FB-135	328				
01205	288	01205	288					77	314					FB-134	327				
P.139	228			DF-5	293			98	315	FB-146	319			FB-135	328				
P.141	229	01205	288	DF-12	297			77	314					FB-134	327				
P.139	228			DF-7	294														
P.141	229			DF-7	294														
P.173	240			DF-5	293														
P.139	228			DF-1	292														
P.173	240																		
P.079	218	01205	288																
P.079	218	01205	288																
P.143	230			DF-32	304														
P.143	230	P.186	244	DF-32	304														
P.143	230	P.186	244																
P.173	240																		
P.143	230																		
P.143	230	P.186	244	DF-32	304														
P.143	230	P.186	244																
P.079	218																		
P.143	230	P.186	244	DF-32	304														
P.165	235			DF-11	296	DF-33	304												
P.165	235	P.180	242	DF-11	296	DF-33	304												
P.143	230	P.143	230																
P.150	232	P.213	257																
P.246	271																		
								29	312										
								29	312										
								29	312										
								27	312										
								29	312										
								29	312										
								29	312										
								29	312										
								29	312										



Serie
Dischi Rivestiti
Friction Plate Kit



RACING
Serie
Dischi Rivestiti
Friction Plate Kit



Serie Completa
Dischi Frizione
Clutch Plates
Complete Set



RACING
Serie Completa
Dischi Frizione
Clutch Plates
Complete Set



Frizione
Antisaltemento
Slipper Clutches



Carter Frizione
Clutch Covers

MARCA - MODELLO MAKE - MODEL

MINARELLI		CC	MY	COD	PAG	COD	PAG	COD	PAG	COD	PAG	COD	PAG	COD	PAG
DT RAFFR. ACQUA		125	88												
DT RAFFR. ACQUA YPVS		125	88												
MONDIAL		CC	MY												
EVO		1000	04												
PIEGA		1000	03												
RZ NUDA		1000	04												
STARFIGHTER		1000	04												
MONTESA		CC	MY												
COTA		304	86												
COTA		307	87												
COTA		309	89												
COTA R		315	99	00											
COTA R		315	01												
COTA		330	87												
COTA		335	87												
COTA TRIAL-EXCURSION		335	89												
ENDURO H7		360	85												
ENDURO H7		360	86												
ENDURO H7		360	87												
MORINI		CC	MY												
COUNTRY		250	88	MR-65	156										
DART		350	88	MR-65	156										
EXCALIBUR		350	86	MR-65	156										
KANGURO		350	88	MR-65	156										
NEW YORK		350	88	MR-65	156										
DART		400	89	MR-65	156										
S		400	95	MR-65	156										
CAMEL		501	88	MR-65	156										
COGUARO		501	88	MR-65	156										
COGUARO		501	89	MR-65	156										
EXCALIBUR		501	86	MR-65	156										
EXCALIBUR		501	88	MR-65	156										
EXCALIBUR		501	89	MR-65	156										
IXE		501	88	MR-65	156										
NEW YORK		501	88	MR-65	156										
NEW YORK		501	89	MR-65	156										
CORSARO		1200	05												
MOTO GUZZI		CC	MY												
BX		125	92												
C		125	92												
TT-C		125	85												
TS		250	75												
FALCO		350	88												
IMOLA		350	78												
NEVADA		350	92												
NTX 350		350	90												
V 35 350 GT		350	90												
V 35 FLORIDIA III		350	92												
V 35 I-II-III-C-TT		350	78												
GTS		400	79												
MONZA		500	78												
V 50 I-II-III-MONZA CHOPER		500	80												
V 50 POLIZIA MILITARE		500	80												
GT SESSANTACINQUE		650	89												
NTX		650	88												
NTX 650		650	90												
V 65 650 GT		650	90												
V 65 BAJA		650	86												
V 65 C		650	85												
V 65 FLORIDIA		650	86												

MARCA - MODELLO MAKE - MODEL



Serie
Dischi Rivestiti
Friction Plate Kit



RACING
Serie
Dischi Rivestiti
Friction Plate Kit



Serie Completa
Dischi Frizione
Clutch Plates
Complete Set



RACING
Serie Completa
Dischi Frizione
Clutch Plates
Complete Set

APTC
Adler Power Torque Clutch

Frizione
Antisaltemento
Slipper Clutches



Carter Frizione
Clutch Covers

MOTO GUZZI	CC	MY	COD	PAG	COD	PAG	COD	PAG	COD	PAG	COD	PAG	COD	PAG
V 65 LARIO	650	82												
V 65 SP-TT-CHOPER-POLIZIA	650	76												
V 65 TT	650	85												
VT TT BAJA	650	86												
BREVA I.E.	750	03												
NEVADA CLASSIC I.E.	750	03												
NEVADA CLUB	750	98	02											
NEVADA CLUB	750	03	04											
NTX	750	89												
NTX 750	750	90												
S 750	750	74												
S3 750	750	75												
SP	750	92												
STR V I.E.	750	03												
TARGA	750	89												
V 75	750	76												
BREVA	850	06												
CALIFORNIA 850 T3	850	75												
GRISO	850	06												
LE MANS 850	850	76												
T 850	850	74												
T 5 850	850	84												
T3 850	850	75												
T4 850	850	80												
CALIFORNIA 1000 III C	1000	91												
DAYTONA	1000	92												
DAYTONA 1000	1000	91												
EV STONE	1000	02												
GRISO	1000	03												
GT V 1000	1000	91												
LE MANS 1000	1000	84												
LE MANS V 1000	1000	90												
MILLE GT	1000	92												
SP 1000	1000	78												
SP 1000 II	1000	84												
SP III 1000	1000	91												
V 1000 1000 G5	1000	78												
V 1000 1000 I CONVERT	1000	75												
V 11 SPORT BALLABIO	1000	03												
BREVA V	1100	05												
CALIFORNIA 1100	1100	94												
CALIFORNIA EV	1100	99												
CALIFORNIA I	1100	94												
CALIFORNIA JACKAL	1100	99												
CALIFORNIA SPECIAL	1100	99												
FIONDA	1100	05												
GRISO	1100	05												
SPORT	1100	95												
SPORT 1100	1100	01												
V 10 CENTAURO SPORT	1100	99												
V 11 LE MANS	1100	03												
V 11 SCURA	1100	03												
V 11 SPORT	1100	00												
NORGE	1200	06												
NORGE 1200 GT 8V	1200	11												
SPORT	1200	07												
MOTO TM	CC	MY												
GS-MC	80	86	89											
GS-MC	80	90	92											
GS-MC	80	93												

FRENI - BRAKES

VALVOLE - REEDS

COLLETTORI INTAKE MANIFOLDS

FERMACOPERTONI TIRE LOCKS

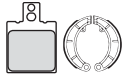

Pastiglie/Ganasce Anteriori
Front Brake Pads/Shoes

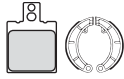

Pastiglie/Ganasce Posteriori
Rear Brake Pads/Shoes



Dischi Freno Anteriore
Front Brake Disk



Dischi Freno Posteriori
Rear Brake Disk



Lamelle
Reeds



Valvole Lamellari
Reed Valve



Valvola Power Reed
Power Reed Valve



Collettori Aspirazione
Intake Manifolds



Fermacopertoni Anteriore
Front Tire Locks



Fermacopertoni Posteriori
Rear Tire Locks

COD	PAG	COD	PAG	COD	PAG	COD	PAG	COD	PAG	COD	PAG	COD	PAG	COD	PAG	COD	PAG	COD	PAG
P.012	208	P.012	208																
P.012	208	P.012	208																
P.012	208	P.012	208																
		P.012	208																
P.168	236	P.012	208																
P.168	236	P.186	244																
P.012	208	P.012	208																
P.168	236	P.186	244																
P.012	208	P.012	208																
		P.245	270																
P.245	270																		
P.245	270	P.245	270																
P.012	208	P.012	208																
P.168	236	P.012	208																
P.012	208	P.012	208																
P.012	208	P.012	208																
P.168	236	P.186	244																
P.245	270	P.245	270																
P.168	236	P.186	244																
P.245	270	P.245	270																
P.245	270																		
P.245	270	P.245	270																
P.245	270	P.245	270																
P.245	270	P.245	270																
P.245	270	P.245	270																
P.245	270	P.245	270																
P.067	214	P.012	208																
		P.245	270																
P.168	236	P.186	244																
P.211	256	P.012	208																
P.245	270	P.245	270																
P.245	270	P.245	270																
P.245	270	P.245	270																
		P.012	208																
P.245	270																		
P.245	270	P.245	270																
P.245	270	P.245	270																
P.245	270	P.245	270																
P.245	270	P.245	270																
P.168	236	P.186	244																
P.168	236	P.192	247																
P.245	270	P.245	270																
		P.143	230																
P.067	214																		
P.067	214	P.143	230																
P.067	214	P.143	230																
P.211	256	P.186	244																
P.168	236	P.192	247																
P.067	214	P.012	208																
		P.245	270																
P.067	214	P.012	208																
P.168	236	P.012	208																
P.168	236	P.012	208																
P.168	236	P.012	208																
P.168	236	P.231	263																
P.168	236	P.231	263																
P.168	236	P.192	247																
		P.012	208																
		P.075	217																
P.143	230	P.172	238																

MARCA - MODELLO MAKE - MODEL



Serie
Dischi Rivestiti
Friction Plate Kit



RACING
Serie
Dischi Rivestiti
Friction Plate Kit



Serie Completa
Dischi Frizione
Clutch Plates
Complete Set



RACING
Serie Completa
Dischi Frizione
Clutch Plates
Complete Set



Frizione
Antisaltemento
Slipper Clutches



Carter Frizione
Clutch Covers

MOTO TM	CC	MY	COD	PAG	COD	PAG	COD	PAG	COD	PAG	COD	PAG	COD	PAG
MX	85	05												
CROSS	125	00												
ENDURO	125	00	03											
ENDURO	125	04												
GS-MC	125	90	92											
GS-MC	125	93												
MX	125	05												
ENDURO 4T	250	00	03											
ENDURO 4T	250	04												
CROSS 4T	400	00												
EN F ES	450	05												
MX F	450	05												
SMM F BLACK DREAM ES	450	05												
SMR	450	06												
SMR F ES	450	05												
SMX	450	05	06											
EN F ES	530	05												
MX F	530	05												
SMR	530	06												
SMR F ES	530	05												
SMX F	660	04												
MOTORHISPANIA	CC	MY												
MX FURIA	50	00												
RX RACING	50	00	03											
RYZ CROSS	50	04	05											
RYZ ENDURO	50	05												
RYZ SUPERMOTARD	50	04	05											
MOTRON	CC	MY												
SPIKE	50	98												
STING	50	95												
SYNCR0	50	98												
THUNDER SC	50	95												
MUZ	CC	MY												
SKORPION	500	94												
BAGHIRA	660	00												
MASTIFF	660	00												
S	1000	01												
MV AGUSTA	CC	MY												
RIVALE	800	13												
RIVALE 800	800	13												
STRADALE 800	800	15												
TURISMO VELOCE 800	800	14												
BRUTALE R ITALIA	910	07												
BRUTALE R-S	910	05	06											
F4	1000	06	07											
F4 R	1000	07												
BRUTALE RR	1078	08	09											
F4 RR	1078	08	09											
BRUTALE RR	1090	10												
MZ	CC	MY												
ETZ 125	125	82												
ETZ 125	125	85												
ROADSTAR 125	125													
SM 125	125	02												
SPORTSTAR 125	125	93												
SX 125	125	02												
ETZ 150	150	82												
ETZ 250	250	82												
SPORTSTAR 251	251	96												
ETZ 300	300	88												

FRENI - BRAKES

VALVOLE - REEDS

COLLETTORI INTAKE MANIFOLDS

FERMACOPERTONI TIRE LOCKS

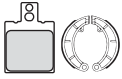

Pastiglie/Ganasce Anteriore
Front Brake Pads/Shoes

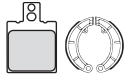

Pastiglie/Ganasce Posteriori
Rear Brake Pads/Shoes



Dischi Freno Anteriore
Front Brake Disk



Dischi Freno Posteriori
Rear Brake Disk



Lamelle
Reeds



Valvole Lamellari
Reed Valve



Valvola Power Reed
Power Reed Valve



Collettori Aspirazione
Intake Manifolds



Fermacopertoni Anteriore
Front Tire Locks



Fermacopertoni Posteriori
Rear Tire Locks

COD	PAG	COD	PAG	COD	PAG	COD	PAG	COD	PAG	COD	PAG	COD	PAG	COD	PAG	COD	PAG	COD	PAG
P.143	230	P.205	253																
P.143	230	P.172	238																
P.143	230	P.172	238																
P.143	230	P.205	253																
		P.075	217																
P.143	230	P.172	238																
P.143	230	P.205	253																
P.143	230	P.172	238																
P.143	230	P.205	253																
P.143	230	P.172	238																
P.143	230	P.205	253																
P.143	230	P.205	253																
P.211	256	P.205	253																
P.067	214	P.205	253																
P.211	256	P.205	253																
P.143	230	P.205	253																
P.143	230	P.205	253																
P.211	256	P.205	253																
P.067	214																		
P.211	256	P.205	253																
P.065	213	P.065	213																
P.133	227	P.065	213																
P.065	213	P.065	213																
P.065	213	P.065	213																
P.133	227	P.065	213																
P.139	228							98	315	FB-146	319			FB-135	328				
P.071	215	01200	288	DF-6	294			77	314					FB-134	327				
P.139	228							98	315	FB-146	319			FB-135	328				
P.139	228	01200	288			DF-8	295	77	314					FB-134	327				
		P.012	208																
		P.075	217																
P.074	216	P.075	217																
P.168	236	P.186	244																
P.233	264																		
P.233	264																		
P.233	264																		
P.233	264																		
P.211	256																		
P.211	256																		
P.211	256																		
P.229	262																		
P.229	262																		
P.229	262																		
P.229	262																		
P.245	270																		
P.245	270																		
P.245	270																		
P.259	277																		
P.245	270																		
P.259	277																		
P.245	270																		
P.245	270																		
P.245	270	P.245	270																
P.245	270																		

MARCA - MODELLO MAKE - MODEL



Serie
Dischi Rivestiti
Friction Plate Kit



RACING
Serie
Dischi Rivestiti
Friction Plate Kit



Serie Completa
Dischi Frizione
Clutch Plates
Complete Set



RACING
Serie Completa
Dischi Frizione
Clutch Plates
Complete Set



Frizione
Antisaltemento
Slipper Clutches



Carter Frizione
Clutch Covers

MZ	CC	MY	COD	PAG	COD	PAG	COD	PAG	COD	PAG	COD	PAG	COD	PAG
ETZ 301	301	90												
SPORTSTAR 301	301	96												
SAXON 500 all models	500	92												
SILVER 500 STAR CLASSIC	500	93												
NORTON	CC	MY												
COMMANDER	0	90												
INTERPOL 2ROTARY	0	83												
WANKEL CLASSIC 2ROTARY	0	88												
PETERSON	CC	MY												
HURRICANE 50	50	95												
SR 50 RACING	50	95												
HURRICANE 80	80	95												
SR 80 RACING	80	95												
PEUGEOT	CC	MY												
103-104 ALL MODELS	48		PG-1	156										
BUXI RS 50	50	94												
BUXY RS	50	94												
ELISEO	50	98	02											
ELISEO	50	03												
ELISTAR	50	02	03											
ELISTAR AVANTAGE 2	50	04												
FOX	50	95												
JET FORCE	50	03												
LOOXOR	50	01												
LUDIX BULLET	50	04												
LUDIX ELEGANCE	50	04												
LUDIX SNAKE	50	04												
LUDIX TREND	50	04												
NK 7 50	50	09												
SPEEDAKE	50	95												
SPEEDFIGHT	50	96												
SPEEDFIGHT M Pin. HengTong	50	97												
SPEEDFIGHT ARIA	50	97												
SPEEDFIGHT H20	50	97												
SQUAB	50	95												
SQUAB 50	50	96												
SV GEO	50	92												
SV GEO	50	93												
TREKKER 50 ROAD	50	97												
TREKKER OFF ROAD	50	97												
TREKKER ROAD	50	97												
VIVACITY	50	99												
VIVACITY pinza HengTong	50	05												
XP S6 ENDURO	50	04												
XP S6 SUPERMOTARD	50	04												
XR 6	50	05												
XR 7 50	50	08												
ZENITH	50	94	95											
ZENITH	50	96												
SPEEDFIGHT	80	96												
SV GEO	80	91												
ZENITH LUXE	80	96												
ELISEO	100	98	02											
ELISEO	100	03												
LOOXOR	100	02												
SPEEDFIGHT	100	97												
TREKKER ROAD	100	98												
VIVACITY	100	99												
ELISEO	125	98	01											
ELISEO	125	03												

FRENI - BRAKES

VALVOLE - REEDS

COLLETTORI INTAKE MANIFOLDS

FERMACOPERTONI TIRE LOCKS

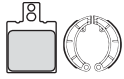

Pastiglie/Ganasce Anteriore
Front Brake Pads/Shoes

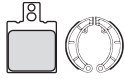

Pastiglie/Ganasce Posteriori
Rear Brake Pads/Shoes



Dischi Freno Anteriore
Front Brake Disk



Dischi Freno Posteriori
Rear Brake Disk



Lamelle
Reeds



Valvole Lamellari
Reed Valve



Valvola Power Reed
Power Reed Valve



Collettori Aspirazione
Intake Manifolds



Fermacopertoni Anteriore
Front Tire Locks



Fermacopertoni Posteriori
Rear Tire Locks

COD	PAG	COD	PAG	COD	PAG	COD	PAG	COD	PAG	COD	PAG	COD	PAG	COD	PAG	COD	PAG	COD	PAG
P.245	270																		
P.245	270	P.245	270																
P.245	270	P.245	270																
P.245	270	P.245	270																
P.245	270	P.245	270																
P.245	270	P.245	270																
P.245	270	P.245	270																
		P.260	277																
		P.260	277																
		P.260	277																
		P.260	277																
P.260	277																		
P.139	228			DF-8	295														
P.065	213			DF-8	295														
P.065	213	P.065	213	DF-8	295														
P.065	213	P.201	251																
P.065	213	P.201	251																
P.065	213			DF-8	295														
P.065	213	P.065	213	DF-8	295														
P.065	213																		
P.065	213			DF-6	294														
P.065	213			DF-8	295														
P.065	213			DF-6	294														
P.065	213			DF-6	294														
P.246	271																		
P.139	228			DF-8	295														
P.030	210			DF-9	295														
P.260	277																		
P.065	213			DF-9	295														
P.065	213	P.065	213	DF-8	295	DF-9	295												
P.065	213			DF-8	295														
P.260	277																		
				DF-8	295														
P.093	221			DF-8	295														
P.260	277																		
P.030	210			DF-8	295														
P.030	210			DF-8	295														
P.065	213			DF-8	295														
P.260	277																		
P.065	213	P.065	213																
P.158	233	P.065	213																
P.133	227	P.065	213																
P.246	271																		
				DF-6	294														
P.065	213			DF-6	294														
P.030	210					DF-9	295												
				DF-8	295														
P.139	228																		
P.065	213																		
P.065	213	P.065	213																
P.208	255	P.065	213																
P.065	213	P.065	213	DF-9	295	DF-9	295												
P.065	213			DF-8	295														
P.065	213			DF-8	295														
P.158	233																		
P.158	233	P.201	251																

MARCA - MODELLO MAKE - MODEL



Serie
Dischi Rivestiti
Friction Plate Kit



RACING
Serie
Dischi Rivestiti
Friction Plate Kit



Serie Completa
Dischi Frizione
Clutch Plates
Complete Set



RACING
Serie Completa
Dischi Frizione
Clutch Plates
Complete Set



Frizione
Antisaltemento
Slipper Clutches



Carter Frizione
Clutch Covers

PEUGEOT	CC	MY	COD	PAG	COD	PAG	COD	PAG	COD	PAG	COD	PAG	COD	PAG
ELISTAR	125	02	03											
GEPOLIS	125	06												
JET FORCE	125	03												
LOOXOR	125	03												
SATELIS K15	125	06												
SV GEO	125	92												
SV GEO	125	95												
ELISEO	150	98	01											
ELISEO	150	03												
ELISTAR	150	02	03											
LOOXOR	150	03												
GEPOLIS PREMIUM	250	06												
SATELIS CITY	250	06												
SV	250	03												
SV	250	01	02											
SATELIS	500	06												
PGO	CC	MY												
BIG MAX	50	95												
BIG MAX 50	50	03												
COMET	50	91	95											
COMET 50	50	91												
GALAXI 50	50	92												
GALAXI 90	50	92												
GALAXY	50	92												
HOT	50	98												
MEGA 50	50													
MEGA FIFTY	50	99												
PMS	50	99												
PMX	50	99												
PS 50	50	93												
RODOSHOW	50	01												
T REX	50	99												
TORNADO	50	96												
BIG MAX	80	95												
MY BUBU	100	02												
PMS	110	99												
T REX	110	99												
CHARGE	125	02												
MY BUBU	125	02												
T REX 2T	125	99												
TORNADO	125	96												
T REX 4T	150	00												
TR 3	150	02												
PGO ATV	CC	MY												
X RIDER 50	50	03												
X RIDER 125	125	03												
X RIDER 150	150	03												
PIAGGIO	CC	MY												
APE FL / FL2	50	89	95											
APE FL3 EUROPA	50	96	99											
APE RST MIX	50	99	05											
APE TL 1 SERIE	50			VE-160	162			VE-346	190	VE-247	190			
APE TL 2 SERIE	50			VE-160	162			VE-346	190	VE-247	190			
BOSS-GRILLO	50	89												
CIAO-BRAVO-BOXER-SI	50													
DIESIS	50	02												
FLY (E.U.)	50	05												
FLY (U.S.)	50	05												
FREE	50	96	00											
FREE	50	01												

FRENI - BRAKES

VALVOLE - REEDS

COLLETTORI INTAKE MANIFOLDS

FERMACOPERTONI TIRE LOCKS

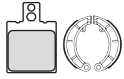

Pastiglie/Ganasce Anteriore
Front Brake Pads/Shoes

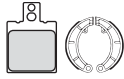

Pastiglie/Ganasce Posteriori
Rear Brake Pads/Shoes



Dischi Freno Anteriore
Front Brake Disk



Dischi Freno Posteriori
Rear Brake Disk



Lamelle
Reeds



Valvole Lamellari
Reed Valve



Valvola Power Reed
Power Reed Valve



Collettori Aspirazione
Intake Manifolds



Fermacopertoni Anteriore
Front Tire Locks



Fermacopertoni Posteriori
Rear Tire Locks

COD	PAG	COD	PAG	COD	PAG	COD	PAG	COD	PAG	COD	PAG	COD	PAG	COD	PAG	COD	PAG	COD	PAG
P.158	233	P.201	251																
P.204	253	P.204	253																
P.158	233	P.201	251																
P.194	248	P.065	213																
P.158	233	P.065	213																
				DF-8	295														
P.093	221			DF-8	295														
P.158	233																		
P.158	233	P.201	251																
P.158	233																		
P.208	255	P.065	213																
P.204	253	P.204	253																
P.186	244	P.175	240																
P.194	248	P.134	228	DF-25	301														
P.194	248			DF-25	301														
P.186	244	P.186	244																
P.141	229			DF-12	297			83	314					VE-371	329				
P.260	277																		
P.030	210																		
P.260	277																		
P.260	277																		
P.260	277																		
P.030	210																		
P.141	229			DF-12	297														
P.260	277																		
P.141	229							83	314					VE-371	329				
P.188	245			DF-5	293			83	314					VE-371	329				
P.141	229			DF-12	297			83	314					VE-371	329				
P.260	277																		
P.158	233																		
P.188	245			DF-5	293			83	314					VE-371	329				
P.141	229			DF-12	297														
P.141	229																		
P.188	245																		
P.188	245			DF-5	293														
P.188	245			DF-5	293														
P.188	245																		
P.188	245																		
P.188	245																		
P.141	229																		
P.188	245																		
P.188	245																		
		P.260	277																
		P.260	277																
		P.260	277																
0162	285																		
0162	285																		
0162	285																		
0162	285																		
		0187	285																
		0187	285																
P.065	213	01284	289																
P.204	253	0281	287					83	314					VE-371	329				
P.175	240	P.212	257					83	314					VE-371	329				
P.098	222	0275	286	DF-10	296			83	314					VE-371	329				
P.098	222	01284	289	DF-10	296			83	314					VE-371	329				

MARCA - MODELLO MAKE - MODEL



Serie
Dischi Rivestiti
Friction Plate Kit



RACING
Serie
Dischi Rivestiti
Friction Plate Kit



Serie Completa
Dischi Frizione
Clutch Plates
Complete Set



RACING
Serie Completa
Dischi Frizione
Clutch Plates
Complete Set



Frizione
Antisaltemento
Slipper Clutches



Carter Frizione
Clutch Covers

PIAGGIO	CC	MY	COD	PAG	COD	PAG	COD	PAG	COD	PAG	COD	PAG	COD	PAG
FREE	50	02												
FREE (RUOTE IN LEGA)	50	96												
HP	50	92												
LIBERTY	50	97	07											
LIBERTY 4T	50	00	07											
LIBERTY S	50	08												
LIBERTY S 4T	50	08												
NRG EXTREME	50	01												
NRG EXTREME ACQUA	50	96	00											
NRG EXTREME ARIA	50	96	00											
NRG POWER DD	50	05												
NRG=MC2	50	99												
NTT	50	95												
QUARTZ	50	91	95											
SFERA	50	90	95											
SFERA	50	96												
SFERA ET2	50	97												
SFERA RST	50	95												
TYPHOON	50	94	97											
TYPHOON	50	07	08											
TYPHOON	50	01	03											
TYPHOON X	50	98	00											
TYPHOON SE	50	06												
ZIP	50	93	95											
ZIP 4T KAT.	50	00												
ZIP FAST RIDER	50	93												
ZIP FAST RIDER	50	00												
ZIP II	50	01												
ZIP RST	50	96	99											
ZIP RST	50	00												
ZIP SP L.C.	50	96	99											
ZIP SP L.C.	50	00												
SFERA	80	94												
SKIPPER	80	94												
TYPHOON	80	96												
DIESIS	100	01	03											
FLY	100	07												
FREE	100	02												
ZIP	100	07												
BEVERLY	125	07												
BEVERLY B 4T (G)	125	02	06											
BEVERLY B 4T (H)	125	02	06											
BEVERLY S	125	07												
COSA	125	89		VE-155	162									
COSA II	125	92		VE-362	163			VE-364	191					
HEXAGON	125	94	97											
HEXAGON GTX (G)	125	00												
HEXAGON GTX (H)	125	00												
HEXAGON LX (G)	125	98	99											
HEXAGON LX (H)	125	98	99											
LIBERTY 4T	125	97	99											
LIBERTY 4T	125	00	07											
LIBERTY S 4T	125	07												
SFERA	125	95												
SFERA 4T	125	96												
SKIPPER	125	93												
SKIPPER LX	125	96	97											
SKIPPER LX 2T (G)	125	98	99											
SKIPPER LX 2T (H)	125	98	99											
SKIPPER ST 4T (G)	125	00												

FRENI - BRAKES

VALVOLE - REEDS

COLLETTORI INTAKE MANIFOLDS

FERMACOPERTONI TIRE LOCKS

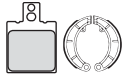

Pastiglie/Ganasce Anteriori
Front Brake Pads/Shoes

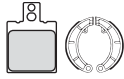

Pastiglie/Ganasce Posteriori
Rear Brake Pads/Shoes



Dischi Freno Anteriore
Front Brake Disk



Dischi Freno Posteriori
Rear Brake Disk



Lamelle
Reeds



Valvole Lamellari
Reed Valve



Valvola Power Reed
Power Reed Valve



Collettori Aspirazione
Intake Manifolds



Fermacopertoni Anteriore
Front Tire Locks



Fermacopertoni Posteriori
Rear Tire Locks

COD	PAG	COD	PAG	COD	PAG	COD	PAG	COD	PAG	COD	PAG	COD	PAG	COD	PAG	COD	PAG	COD	PAG
P.139	228	01284	289	DF-10	296			83	314					VE-371	329				
		0266	286																
0161	285	0161	285																
P.175	240	0281	287					83	314					VE-371	329				
P.175	240	0281	287											VE-371	329				
P.175	240	0281	287																
P.175	240	0281	287																
P.175	240	P.175	240	DF-1	292			83	314					VE-371	329				
P.139	228	P.175	240	DF-1	292			83	314					VE-371	329				
P.139	228	0275	286	DF-1	292			83	314					VE-371	329				
		P.175	240																
P.139	228	P.175	240	DF-19	299			83	314					VE-371	329				
P.139	228			DF-1	292			83	314					VE-371	329				
P.144	231	0266	286	DF-10	296			83	314					VE-371	329				
		0266	286					83	314					VE-371	329				
P.173	240	0275	286	DF-10	296			83	314					VE-371	329				
P.175	240	01284	289	DF-10	296			83	314					VE-371	329				
		0275	286					83	314					VE-371	329				
P.139	228	0275	286	DF-1	292			83	314					VE-371	329				
P.030	210	01200	288					83	314					VE-371	329				
P.139	228	01284	289					83	314					VE-371	329				
P.139	228	0275	286	DF-1	292			83	314					VE-371	329				
P.030	210	01284	289	DF-1	292			83	314					VE-371	329				
		0266	286					83	314					VE-371	329				
P.175	240	01284	289											VE-371	329				
P.139	228	0266	286					83	314					VE-371	329				
P.175	240							83	314					VE-371	329				
P.175	240	01284	289					83	314					VE-371	329				
P.175	240	01284	289	DF-10	296			83	314					VE-371	329				
P.175	240	0275	286	DF-10	296			83	314					VE-371	329				
P.175	240	01284	289	DF-10	296			83	314					VE-371	329				
P.175	240	01284	289					83	314					VE-371	329				
		0266	286																
				DF-10	296														
P.175	240	0275	286	DF-1	292			83	314					VE-371	329				
P.065	213																		
P.204	253	0281	287																
P.139	228	0281	287																
P.175	240	01284	289																
P.204	253			DF-31	303	DF-31	303												
P.158	233	P.158	233	DF-31	303	DF-31	303												
P.204	253	P.204	253	DF-31	303	DF-31	303												
P.204	253	P.204	253	DF-31	303	DF-31	303												
P.139	228	01284	289																
P.158	233	P.193	247	DF-10	296	DF-10	296							VE-383	329				
P.204	253	P.193	247	DF-10	296	DF-10	296							VE-383	329				
P.158	233	0278	286	DF-10	296									VE-383	329				
P.204	253	0278	286	DF-10	296									VE-383	329				
P.175	240	0278	286																
P.175	240	0278	286																
P.175	240	0278	286																
		01284	289																
P.175	240	01284	289	DF-10	296														
P.144	231	01284	289	DF-10	296									VE-383	329				
P.158	233	01284	289	DF-10	296									VE-383	329				
P.158	233	0278	286	DF-19	299									VE-383	329				
P.204	253	0278	286	DF-19	299									VE-383	329				
P.158	233	01284	289																

MARCA - MODELLO MAKE - MODEL



Serie
Dischi Rivestiti
Friction Plate Kit



RACING
Serie
Dischi Rivestiti
Friction Plate Kit



Serie Completa
Dischi Frizione
Clutch Plates
Complete Set



RACING
Serie Completa
Dischi Frizione
Clutch Plates
Complete Set



Frizione
Antisaltemento
Slipper Clutches



Carter Frizione
Clutch Covers

PIAGGIO	CC	MY	COD	PAG	COD	PAG	COD	PAG	COD	PAG	COD	PAG	COD	PAG
SKIPPER ST 4T (H)	125	00												
SUPERHEXAGON GTX (H)	125	01												
TYPHOON	125	96	98											
TYPHOON X	125	99	03											
X 125 EVO	125	07												
X 8 4T	125	04	05											
X 8 4T	125	05	06											
X 8 I.E.	125	07												
X 9	125	00	02											
X 9 EVOLUTION	125	03	05											
X 9 EVOLUTION	125	06												
X9 125 EVOLUTION	125	05												
X9 125 EVOL. pin. dx HengTong	125	01												
ZIP 4T KAT.	125	00												
COSA	150	89		VE-155	162									
COSA II	150	92		VE-362	163			VE-364	191					
FLY 4T	150	05												
HEXAGON	150	94	99											
LIBERTY 4T	150	00												
SKIPPER LXT 2T	150	98												
HEXAGON	180	00												
HEXAGON LXT (G)	180	98	99											
HEXAGON LXT (H)	180	98	99											
X 8	180	07												
X 9 AMALFI	180	00	03											
BV (G)	200	02	06											
COSA	200	89		VE-121	162									
COSA II	200	92		VE-362	163			VE-364	191					
LIBERTY 4T	200	05												
X 8 4T	200	04	05											
X 9 AMALFI	200	01	02											
X 9 EVOLUTION	200	03	04											
BEVERLY 4T	250	04												
BEVERLY I.E.	250	07												
BEVERLY S I.E.	250	07												
HEXAGON GT 4T (G)	250	98	99											
HEXAGON GT 4T (H)	250	98	99											
HEXAGON GTX (G)	250	00												
HEXAGON GTX (H)	250	00												
MP3	250	07	08											
MP3 250 MIC	250	08												
SUPERHEXAGON GTX	250	01												
X 250 EVO	250	07												
X 8 I.E.	250	07												
X 9	250	00	04											
X 9	250	05	06											
X7 250 EURO 3	250	08												
X9 250 EVOLUTIONpinza sx	250	05												
BEVERLY I.E.	400	07												
X 8 I.E.	400	07												
X EVO 400pinza dx	400	07												
X8 400 EURO 3pinza dx	400	06												
X8 400pinza sx	400	06												
BEVERLY	500	06												
BEVERLY B 4T	500	02	05											
BEVERLY I.E.	500	07												
BV	500	06	08											
MP3 I.E.	500	08												
X 9	500	00	02											
X 9 EVOLUTION ABS	500	03	06											

FRENI - BRAKES

VALVOLE - REEDS

COLLETTORI INTAKE MANIFOLDS

FERMACOPERTONI TIRE LOCKS

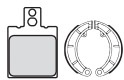

Pastiglie/Ganasce Anteriori
Front Brake Pads/Shoes

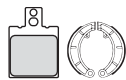

Pastiglie/Ganasce Posteriori
Rear Brake Pads/Shoes



Dischi Freno Anteriori
Front Brake Disk



Dischi Freno Posteriori
Rear Brake Disk



Lamelle
Reeds



Valvole Lamellari
Reed Valve



Valvola Power Reed
Power Reed Valve



Collettori Aspirazione
Intake Manifolds



Fermacopertoni Anteriori
Front Tire Locks



Fermacopertoni Posteriori
Rear Tire Locks

COD	PAG	COD	PAG	COD	PAG	COD	PAG	COD	PAG	COD	PAG	COD	PAG	COD	PAG	COD	PAG	COD	PAG
P.204	253	01284	289	DF-19	299														
P.158	233	P.193	247	DF-10	296	DF-10	296												
P.139	228	01284	289	DF-1	292														
P.139	228	0278	286	DF-1	292														
		P.261	278																
P.204	253	P.186	244	DF-31	303														
P.204	253	P.212	257	DF-31	303														
P.204	253	P.212	257	DF-31	303	DF-30	303												
P.186	244	P.186	244																
P.186	244	P.186	244																
P.186	244	P.212	257	DF-30	303	DF-30	303												
P.261	278																		
P.261	278																		
P.175	240	01284	289	DF-10	296														
P.204	253																		
P.175	240	01284	289											VE-383	329				
P.175	240	0278	286																
P.158	233	0278	286	DF-19	299									VE-383	329				
P.158	233	P.175	240	DF-10	296	DF-10	296												
P.158	233	0278	286	DF-10	296									VE-383	329				
P.204	253	0278	286	DF-10	296									VE-383	329				
P.204	253	P.212	257	DF-31	303	DF-30	303												
P.186	244	P.186	244	DF-30	303	DF-30	303												
P.158	233	P.158	233																
P.204	253	P.204	253			DF-31	303												
P.204	253	P.186	244	DF-31	303														
P.186	244	P.186	244	DF-30	303	DF-30	303												
P.186	244	P.186	244																
P.204	253	P.204	253	DF-31	303	DF-31	303												
P.204	253	P.204	253	DF-31	303	DF-31	303												
P.204	253	P.204	253	DF-31	303	DF-31	303												
P.158	233			DF-10	296														
P.204	253																		
P.158	233	P.193	247	DF-10	296	DF-10	296												
P.204	253			DF-10	296	DF-10	296												
		P.212	257																
		P.261	278																
P.158	233																		
		P.261	278																
		P.212	257																
P.186	244	P.186	244	DF-30	303	DF-30	303												
P.204	253	P.212	257																
		P.261	278																
P.261	278																		
P.143	230	P.186	244	DF-31	303	DF-30	303												
P.204	253	P.212	257																
P.261	278																		
P.261	278																		
P.261	278																		
P.186	244	P.212	257	DF-31	303														
P.186	244	P.186	244	DF-31	303	DF-30	303												
P.186	244	P.186	244			DF-30	303												
P.186	244	P.186	244																
		P.212	257																
P.186	244	P.186	244			DF-30	303												
P.143	230	P.186	244	DF-31	303														

MARCA - MODELLO MAKE - MODEL



Serie
Dischi Rivestiti
Friction Plate Kit



RACING
Serie
Dischi Rivestiti
Friction Plate Kit



Serie Completa
Dischi Frizione
Clutch Plates
Complete Set



RACING
Serie Completa
Dischi Frizione
Clutch Plates
Complete Set



Frizione
Antisaltemento
Slipper Clutches



Carter Frizione
Clutch Covers

PIAGGIO	CC	MY	COD	PAG	COD	PAG	COD	PAG	COD	PAG	COD	PAG	COD	PAG
X 9 I.E.	500	07												
PINZE RACING	CC	MY												
pinza Brembo racingserie 4 pz	0													
POLARIS	CC	MY												
SPORTSMAN 6X6	0	02												
TRAIL BLAZER	0	90	93											
TRAIL BOSS 2X4 - 4X4	0	88	92											
PHOENIX	200	05												
L 2X4 -4X4	250	90	93											
TRAIL BLAZER	250	94	98											
TRAIL BLAZER	250	99												
XPLORER 4X4	250	00												
L 2X4 -4X4	300	94	95											
XPLORER 4X4	300	96	00											
XPRESS 2X4	300	96	00											
MAGNUM 2X4 - 4X4 MOUSE	325	01												
TRAIL BOSS	325	00	02											
XPEDITION	325	00	01											
XPEDITION 4X4	325	02												
ATP	330	04												
MAGNUM 2X4 - 4X4	330	03												
SPORTSMAN 4X4 WORKER	335	99	00											
L 2X4 -4X4	350	90												
L 4X4	350	93												
L 2X4 -4X4	400	94	95											
SCRAMBLER 2X4 - 4X4	400	00												
SPORT	400	99	00											
SPORTSMAN	400	01												
XPLORER L 4X4	400	95	99											
XPLORER L 4X4	400	00												
MAGNUM 4X4	425	95	98											
XPEDITION 4X4	425	00	01											
XPEDITION 4X4	425	02												
DIESEL	455	01												
DIESEL 4X4 EBS	455	99												
ATP	500	04												
BIG BOSS 6X6	500	89	99											
MAGNUM 2X4 - 4X4	500	02												
MAGNUM 4X4	500	99	01											
PREDATOR	500	03												
RANGER	500	00												
SCRAMBLER 4X4	500	97												
SPORTSMAN 4X4	500	96												
SPORTSMAN 4X4	500	01												
XPLORER 4X4	500	97	01											
SPORTSMAN 4X4	700	02												
SPORTSMAN 4X4	800	05												
POLARIS ATV	CC	MY												
TRAIL BOSS	250	88	90											
SPORTSMAN 4x4 WORKER	300	08												
E TRAIL BLAZER	330	08												
OUTLAW MXR 450	450	09												
OUTLAW S 450	450	08												
ATP 500 HO	500	04												
E SCRAMBLER	500	08												
REVOLVER	500	06												
SPORTSMAN HO 500	500	03												
OUTLAW 525	525	07												
OUTLAW IRS 525	525	08												
OUTLAW S 450	525	08												

MARCA - MODELLO MAKE - MODEL



POLARIS ATV		CC	MY	COD	PAG	COD	PAG	COD	PAG	COD	PAG	COD	PAG	COD	PAG
RANGER RZR EFI		570	12												
SPORTSMAN 600		600	02												
RANGER RZR EFI 800		800	08												
RANGER RZR S EFI 800		800	09												
RZR 800		800	08												
SPORTSMAN		800	05												
PUCH		CC	MY												
COBRA M 82		50	85	PU-1	156										
CONDOR		50	85	PU-1	156										
MONZA LUJO		50	85	PU-1	156										
X 10		50	86	PU-1	156										
X 20		50	86	PU-1	156										
MAXI		80	88												
RIEJU		CC	MY												
MRX PRO		50	05	FB-132	142	FB-132/M	142	FB-140	178	FB-140/C	178				
MRX RACING		50	02	FB-132	142	FB-132/M	142	FB-140	178	FB-140/C	178				
NKD		50	05	FB-132	142	FB-132/M	142	FB-140	178	FB-140/C	178				
RACING SPECIAL EDITION		50	01	FB-132	142	FB-132/M	142	FB-140	178	FB-140/C	178				
RS1 CASTROL		50	01	FB-132	142	FB-132/M	142	FB-140	178	FB-140/C	178				
RS2 MATRIX		50	03	FB-132	142	FB-132/M	142	FB-140	178	FB-140/C	178				
SMX		50	02	FB-132	142	FB-132/M	142	FB-140	178	FB-140/C	178				
SPIKE		50	02	FB-132	142	FB-132/M	142	FB-140	178	FB-140/C	178				
SPIKE RACING		50	02	FB-132	142	FB-132/M	142	FB-140	178	FB-140/C	178				
MRX		125	03	FB-127	141			FB-139	177						
RS2 125 NKD		125	06												
RS2 125 PRO		125	08												
SMX		125	03	FB-127	141			FB-139	177						
TANGO 125		125	06												
SACHS		CC	MY												
MAD ASS		50	05												
MAD ASS		125	05												
X ROAD		125	05												
XTC		125	99												
XTC N		125	99												
ZX		125	99												
ZZ		125	99												
MAD ASS		500	05												
ROADSTER V 1.6		650	01												
ROADSTER V 2.0		800	00												
SCORPA		CC	MY												
SY F TRIAL		125	03	06											
TY-S F		125	06												
TY-S F		175	06												
2S5 WORKS		250	95												
SY		250	00	06											
SY F		250	06												
SY LONG RIDE		250	04	05											
T-RIDE F		250	09												
EASY RACE		280	99												
SHERCO		CC	MY												
125		125	99												
2.0		200	99												
2.5		250	99	01											
2.5		250	02												
2.9		290	99												
3.2		320	05												
4.5 ENDURO/SUPERMOTARD		450	04	05											
4.5 IF SUPERMOTO		450	08												
5.1 ENDURO		510	06												

FRENI - BRAKES

VALVOLE - REEDS

COLLETTORI INTAKE MANIFOLDS

FERMACOPERTONI TIRE LOCKS

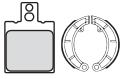

Pastiglie/Ganasce Anteriori
Front Brake Pads/Shoes

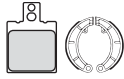

Pastiglie/Ganasce Posteriori
Rear Brake Pads/Shoes



Dischi Freno Anteriore
Front Brake Disk



Dischi Freno Posteriori
Rear Brake Disk



Lamelle
Reeds



Valvole Lamellari
Reed Valve



Valvola Power Reed
Power Reed Valve



Collettori Aspirazione
Intake Manifolds



Fermacopertoni Anteriore
Front Tire Locks



Fermacopertoni Posteriori
Rear Tire Locks

COD	PAG	COD	PAG	COD	PAG	COD	PAG	COD	PAG	COD	PAG	COD	PAG	COD	PAG	COD	PAG	COD	PAG
P.258	276	P.258	276																
		P.258	276																
		P.258	276																
P.258	276																		
P.258	276																		
P.065	213																		
P.065	213																		
P.065	213																		
P.065	213	P.012	208																
P.133	227	P.065	213					29	312										
P.065	213	P.065	213					29	312										
		P.065	213					29	312										
P.133	227	P.065	213					29	312										
P.158	233	P.065	213					29	312										
P.209	255	P.065	213					29	312										
P.133	227	P.065	213					29	312										
P.065	213	P.065	213					29	312										
P.133	227	P.065	213					29	312										
P.133	227	P.065	213					29	312										
P.249	273																		
P.250	273																		
P.133	227	P.065	213																
P.246	271																		
P.073	216	P.065	213																
P.067	214																		
P.067	214																		
P.067	214																		
P.067	214																		
P.074	216																		
P.074	216																		
P.067	214																		
P.067	214																		
P.067	214																		
P.199	250	P.200	250																
P.065	213	P.200	250																
P.065	213	P.200	250																
P.065	213	P.065	213																
P.199	250	P.200	250																
P.199	250	P.200	250																
P.199	250	P.200	250																
		P.201	251																
P.065	213	P.065	213																
P.065	213	P.065	213																
P.065	213	P.065	213																
P.199	250	P.200	250																
P.065	213	P.065	213																
P.199	250	P.200	250																
P.143	230	P.205	253																
P.211	256																		
P.143	230	P.205	253																

MARCA - MODELLO MAKE - MODEL



Serie
Dischi Rivestiti
Friction Plate Kit



RACING
Serie
Dischi Rivestiti
Friction Plate Kit



Serie Completa
Dischi Frizione
Clutch Plates
Complete Set



RACING
Serie Completa
Dischi Frizione
Clutch Plates
Complete Set



Frizione
Antisaltemento
Slipper Clutches



Carter Frizione
Clutch Covers

SIAM	CC	MY	COD	PAG	COD	PAG	COD	PAG	COD	PAG	COD	PAG	COD	PAG
MAT 50	50	97												
MAT 100	100	97												
SULA	CC	MY												
THUNDER BIRD 50	50	99												
THUNDER BIRD 100	100	99												
THUNDER BIRD 125	125	99												
SUZUKI	CC	MY												
ADRESS	50	92	94											
ADRESS	50	92												
ADRESS	50	95												
ADRESS 50	50	92												
AP	50	94												
KATANA	50	97												
KATANA DD	50	99												
OR ET	50	80												
SEPIA 50	50	92												
SEPIA AU 50 ZZ	50	96												
SEPIA AU ZZ	50	96												
TUNE 50	50	93												
UF ESTILETE	50	00												
ZILLION	50	99												
ZR SKX/SKE/SKH	50	83	87											
ZR SLKX	50	81												
ZZ 50	50	92												
LIDO 75	75	89												
AH 80	80	92												
RG 80 GAMMA	80	88												
RM 80 L/M	80	90												
RM 80 X	80	86												
RM K/L	80	89	95											
RM M/N/P/R/S/T/V/W/X/Y/K1	80	96	01											
RM XG/XH/XJ	80	86	88											
RM 85	85	02												
RM K2-K3-K4	85	02	04											
ADRESS 100 V	100	95												
RM B-C	100	77	78	SU-71	160									
AN 125	125	06												
GS ESR/ESX	125	95	00											
GS ESZ	125	82												
LIDO 125 VARIO	125	90												
RG 125 W GAMMA	125	85												
RG FUN-FUP-FUR-FN GAMMA	125	92	96											
RM A/B/C	125	76	78	SU-71	160									
RM E	125	84												
RM F	125	85		SU-71	160									
RM G	125	86												
RM H	125	87												
RM J	125	88												
RM K/L/M	125	89	91											
RM K2/K3/K4/K5/K6/K7	125	02	07											
RM N/P/R/S	125	92	95											
RM T/V/W	125	96	98											
RM X/Y/K1	125	99	01											
RM X/Z/D	125	81	83	SU-71	160									
RV K2/K3/K4 VAN-VAN	125	02	05											
TS RK/RL/RM/RN/RR	125	91	96	SU-71	160									
UH BURGMAN	125	02	06											
UH BURGMAN	125	07												
UE 150	150	02												
UH BURGMAN	150	03												

FRENI - BRAKES

VALVOLE - REEDS

COLLETTORI INTAKE MANIFOLDS

FERMACOPERTONI TIRE LOCKS

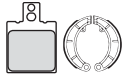

Pastiglie/Ganasce Anteriore
Front Brake Pads/Shoes

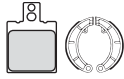

Pastiglie/Ganasce Posteriori
Rear Brake Pads/Shoes



Dischi Freno Anteriore
Front Brake Disk



Dischi Freno Posteriori
Rear Brake Disk



Lamelle
Reeds



Valvole Lamellari
Reed Valve



Valvola Power Reed
Power Reed Valve



Collettori Aspirazione
Intake Manifolds



Fermacopertoni Anteriore
Front Tire Locks



Fermacopertoni Posteriori
Rear Tire Locks

COD	PAG	COD	PAG	COD	PAG	COD	PAG	COD	PAG	COD	PAG	COD	PAG	COD	PAG	COD	PAG	COD	PAG
P.260	277																		
P.260	277																		
P.260	277																		
P.260	277																		
P.260	277																		
P.030	210							90	314										
P.139	228							90	314										
P.260	277							90	314										
P.139	228							90	314										
P.139	228	P.065	213					90	314										
P.075	217																		
P.260	277																		
P.260	277																		
P.030	210																		
P.030	210																		
P.139	228							90	314										
P.065	213							90	314										
P.075	217																		
P.075	217																		
P.260	277																		
P.260	277																		
P.260	277																		
P.241	268																		
P.260	277	P.260	277																
P.260	277																		
P.030	210	P.030	210																
P.030	210	P.030	210																
P.030	210																		
P.260	277	P.260	277																
P.260	277	P.003	208																
P.260	277																		
P.260	277																		
P.075	217																		
P.075	217																		
P.260	277																		
P.241	268																		
P.107	224																		
								13	311							MA-139	332	MA-140	333
								13	311							MA-139	332	MA-140	333
								13	311							MA-139	332	MA-140	333
P.086	220							13	311							MA-139	332	MA-140	333
P.086	220	P.076	218					13	311							MA-139	332	MA-140	333
P.086	220	P.114	225					13	311							MA-139	332	MA-140	333
P.190	246	P.093	221																
								93	315							MA-139	332	MA-140	333
P.190	246	P.093	221					09	310										
P.190	246	P.093	221					09	310										
P.171	238																		
P.086	220																		
P.143	230	P.186	244																
P.227	261	P.086	220																
P.260	277																		
P.143	230	P.186	244																

MARCA - MODELLO MAKE - MODEL



Serie
Dischi Rivestiti
Friction Plate Kit



RACING
Serie
Dischi Rivestiti
Friction Plate Kit



Serie Completa
Dischi Frizione
Clutch Plates
Complete Set



RACING
Serie Completa
Dischi Frizione
Clutch Plates
Complete Set



Frizione
Antisaltemento
Slipper Clutches



Carter Frizione
Clutch Covers

SUZUKI	CC	MY	COD	PAG	COD	PAG	COD	PAG	COD	PAG	COD	PAG	COD	PAG
DR G/H/J	200	86	89											
DR	200	93	98											
RV K2/K3	200	02	03											
UH BURGMAN	200	07												
AN BURGMAN	250	98	03											
AN BURGMAN	250	04	06											
AN BURGMAN	250	07												
AN BURGMAN BUSINESS	250	01	02											
DR R	250	95	00	HO-117	147									
DR R DEJBEL	250	96	98	HO-117	147									
DR Z K1-K5	250	01	05	HO-117	147									
GN F/J/M/N/R/T	250	87	98	SU-78	161									
GS TT/TX	250	80	81	SU-71	160									
GSF N/ZM/P/NP/ZP/R/NR	250	92	96											
GSF VS/S BANDIT	250	97												
GSX ET/EX/EZ	250	80	82	SU-71	160									
GSX FXK2	250	02												
GSX SSM KATANA	250	91												
GSXR CJ/CK	250	88												
GSXR RK	250	89												
LT Z K4-K5-K6-K7	250	04	07											
PE T/X/Z	250	80	82	SU-26	157									
RG WD-WE GAMMA	250	83												
RGV J	250	88		SU-29	158									
RGV K/L	250	89	90	SU-29	158									
RGV M/N/P/R/S	250	91	95	SU-29	158									
RGV T	250	96		SU-29	158									
RM F	250	85		SU-26	157									
RM G	250	86												
RM H	250	87												
RM J/K/L/M	250	88												
RM J/K/L/M	250	89	91											
RM N/P	250	92	93											
RM N/T/X/Z/D	250	79	85	SU-26	157									
RM R/S	250	94	95											
RM T/V/W/X/Y/K1-K2	250	96	02	SU-86	162									
RM Z	250	09											SU-98	204
RM Z K4-K5	250	04												
RM-Z K3-K4-K5-K6-K7	250	03	07											
RMX K/L/M	250	89	91											
RMX N/P	250	92	93											
RMX R/S	250	94	95											
RMX ST/SV/SW/SX	250	96	99											
RMX T/V/W	250	96	98											
SBK2	250	02												
TU GY/GBK1	250	00	01	SU-78	161									
TU S/T/XS/XT/X-ST/XSV	250	92	97	SU-78	161									
TU XTX/XXTY	250	99	00	SU-78	161									
TU XV/XW	250	97	00	SU-78	161									
TV J/K/RK/L	250	88	90	SU-29	158									
VL Y/K1-K5 INTRUDER	250	01	05	SU-78	161									
DR SL-ST-SES-SEX	350	90	99	SU-28	158									
AN 400 BURGMAN pinza dx	400	07												
AN BURGMAN	400	98	03											
AN BURGMAN	400	04	06											
AN BURGMAN LEFT	400	07												
AN BURGMAN RIGHT	400	07												
DR ST-SX	400	80	83	SU-27	158									
DR Z	400	00	07											
DR Z SMK5/SMK6/SMK7	400	05	07											

FRENI - BRAKES

VALVOLE - REEDS

COLLETTORI INTAKE MANIFOLDS

FERMACOPERTONI TIRE LOCKS

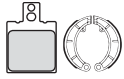

Pastiglie/Ganasce Anteriori
Front Brake Pads/Shoes

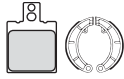

Pastiglie/Ganasce Posteriori
Rear Brake Pads/Shoes



Dischi Freno Anteriore
Front Brake Disk



Dischi Freno Posteriori
Rear Brake Disk



Lamelle
Reeds



Valvole Lamellari
Reed Valve



Valvola Power Reed
Power Reed Valve



Collettori Aspirazione
Intake Manifolds



Fermacopertoni Anteriore
Front Tire Locks



Fermacopertoni Posteriori
Rear Tire Locks

COD	PAG	COD	PAG	COD	PAG	COD	PAG	COD	PAG	COD	PAG	COD	PAG	COD	PAG	COD	PAG	COD	PAG
P.003	208																		
P.003	208																		
P.171	238																		
P.227	261																		
P.183	242	P.063	212	DF-13	297	DF-14	298												
		P.207	254	DF-41	307														
P.183	242	P.207	254	DF-41	307	DF-40	306												
P.183	242	P.207	254	DF-13	297	DF-14	298												
P.190	246	P.114	225																
P.190	246	P.114	225																
P.190	246	P.114	225																
		P.111	225																
P.169	237	P.111	225																
P.171	238																		
		P.111	225																
		P.111	225																
P.107	224	P.111	225																
P.076	218																		
P.045	211	P.045	211																
P.107	224	P.111	225																
P.107	224																		
P.107	224																		
P.086	220	P.076	218					32	313							MA-139	332	MA-153	334
		P.076	218					32	313							MA-139	332	MA-153	334
P.086	220	P.114	225													MA-139	332	MA-153	334
P.086	220	P.114	225													MA-139	332	MA-153	334
P.086	220	P.114	225													MA-139	332	MA-153	334
P.190	246	P.093	221													MA-139	332	MA-153	334
P.190	246	P.205	253																
P.190	246	P.205	253																
P.086	220	P.114	225													MA-139	332	MA-153	334
P.086	220	P.114	225													MA-139	332	MA-153	334
P.086	220	P.114	225													MA-139	332	MA-153	334
P.190	246	P.093	221													MA-139	332	MA-153	334
P.190	246	P.114	225													MA-139	332	MA-153	334
P.190	246	P.093	221													MA-139	332	MA-153	334
P.169	237																		
P.171	238																		
P.107	224	P.111	225																
P.086	220	P.114	225																
		P.266	280																
P.183	242	P.063	212																
		P.207	254	DF-41	307														
P.086	220			DF-41	307	DF-40	306												
P.166	235			DF-41	307														
P.190	246	P.093	221																
P.190	246	P.093	221																

MARCA - MODELLO MAKE - MODEL



Serie
Dischi Rivestiti
Friction Plate Kit



RACING
Serie
Dischi Rivestiti
Friction Plate Kit



Serie Completa
Dischi Frizione
Clutch Plates
Complete Set



RACING
Serie Completa
Dischi Frizione
Clutch Plates
Complete Set



Frizione
Antisaltemento
Slipper Clutches



Carter Frizione
Clutch Covers

SUZUKI	CC	MY	COD	PAG	COD	PAG	COD	PAG	COD	PAG	COD	PAG	COD	PAG
GN TT	400	80	SU-27	158										
GSF K/NK/Z/VM/VZM/P/NP/VP	400	89	94											
GSF M/N/P BANDIT	400	91	95											
GSF V/V/S/V-V/VZ-V BANDIT	400	96	97											
GSR K6	400	06												
GSX ET/EX/EZ	400	80	82	SU-28	158									
LT Z K3- K4-K5	400	03	05											
PE T/X	400	80	81	SU-58	159									
RM N/T	400	79	80	SU-58	159									
SP T	400	80	SU-58	159										
SV	400	99												
GS ET-EG-EJ	450	80	88	SU-28	158									
LT Z	450	08									SU-96	201	SU-97	204
LT Z K5/K6/K7	450	05	07								SU-93	200	SU-94	204
RM Z	450	08									SU-96	201	SU-97	204
RM Z K5/K6/K7	450	05	07								SU-93	200	SU-94	204
RM Z K5/K6/K7/K8	450	05	07											
RM Z K8	450	08												
RM X/Z	465	81	82	SU-29	158									
GS ET/EV/EW/EX/EY/K1-K4	500	89	03	SU-28	158									
GS FK4/FK5/K5	500	04	05	SU-28	158									
GT A-B	500	76	77											
LT F FW/FX/FY/FK1/FK2 PINZA SIN.	500	98	02	SU-65	160									
LT RJ-RK-RL	500	88	90											
RM D	500	83	SU-29	158										
GS DB-C-EC-N-T-X-Z-LT KATANA	550	78	79	SU-12	157									
GSX ESD-EE-ESE-EFE-ESG-ESH	550	84	88	SU-12	157									
DR DJEBEL	600	88	SU-37	159										
DR DJEBEL-DAKAR	600	89	SU-37	159										
DR SF-RG RAIDER	600	85	87	SU-37	159									
GSF BANDIT	600	95	99	SU-29	158									
GSF BANDIT	600	00	04	SU-29	158									
GSF BANDIT PINZA DESTRA	600	00	04											
GSF BANDIT PINZA SINISTRA	600	00	04											
GSR	600	06												
GSX FJ/FK/FL/FM	600	88	91	SU-29	158									
GSX FN/FP/FR/FS/FT/FV	600	92	97											
GSX FW/FX/FY/FK1-FK3	600	98	04	SU-32	158									
GSX R K1-K5	600	01	05	SU-82	161									
GSX R SRAD	600	04	05											
GSX R SRAD	600	06												
GSX R V/W/X/Y	600	97	00	SU-82	161									
VS GLS/GLT INTRUDER	600	95	97	SU-58	159									
AN 650 BURGMAN	650	03												
AN BURGMAN	650	02												
AN BURGMAN EXECUTIVE	650	04	09											
DL V-STROM LEFT	650	04												
DL V-STROM RIGHT	650	04												
DR SET	650	96	SU-73	161										
GSF BANDIT / S BANDIT RIGHT	650	05												
LS FG/PJ/PV SAVAGE	650	87	99	SU-37	159									
SV K3/SK3 PINZA DESTRA	650	03	05											
SV K3/SK3 PINZA SINISTRA	650	03	05											
SV SK3-SK7 PINZA SX	650	03	07											
SV X/SX/Y/SY/K1/SK1-SK2	650	99	02	SU-58	159									
XF V/W/X/Y FREEWIND	650	97	02	SU-73	161									
XN D TURBO	650	83	SU-70	160										
DR SJ	750	88	SU-73	161										
DR SK	750	89	90	SU-73	161									
GSR R	750	11												

FRENI - BRAKES

VALVOLE - REEDS

COLLETTORI INTAKE MANIFOLDS

FERMACOPERTONI TIRE LOCKS

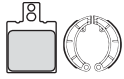

Pastiglie/Ganasce Anteriore
Front Brake Pads/Shoes

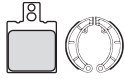

Pastiglie/Ganasce Posteriori
Rear Brake Pads/Shoes



Dischi Freno Anteriore
Front Brake Disk



Dischi Freno Posteriori
Rear Brake Disk



Lamelle
Reeds



Valvole Lamellari
Reed Valve



Valvola Power Reed
Power Reed Valve



Collettori Aspirazione
Intake Manifolds



Fermacopertoni Anteriore
Front Tire Locks



Fermacopertoni Posteriori
Rear Tire Locks

COD	PAG	COD	PAG	COD	PAG	COD	PAG	COD	PAG	COD	PAG	COD	PAG	COD	PAG	COD	PAG	COD	PAG
P.107	224	P.111	225																
		P.111	225																
P.107	224	P.111	225																
P.107	224	P.223	260																
P.076	218																		
P.171	238	P.111	225																
P.190	246	P.205	253																
P.190	246	P.205	253																
P.171	238	P.111	225																
P.171	238	P.111	225																
		P.045	211																
P.086	220																		
P.075	217																		
P.045	211	P.045	211																
P.108	224	P.111	225																
P.171	238																		
P.169	237	P.111	225																
P.107	224	P.223	260																
		P.111	225																
		P.111	225																
P.171	238	P.111	225																
P.215	258	P.218	259																
P.215	258	P.223	260																
P.107	224	P.111	225																
		P.266	280																
P.108	224																		
P.108	224			DF-41	307														
P.169	237	P.134	228																
P.171	238																		
P.190	246	P.114	225																
P.169	237	P.134	228																
P.171	238																		
P.169	237	P.134	228																
P.169	237	P.134	228																
P.169	237	P.111	225																
P.171	238	P.134	228																
P.229	262																		

MARCA - MODELLO MAKE - MODEL



Serie
Dischi Rivestiti
Friction Plate Kit



RACING
Serie
Dischi Rivestiti
Friction Plate Kit



Serie Completa
Dischi Frizione
Clutch Plates
Complete Set



RACING
Serie Completa
Dischi Frizione
Clutch Plates
Complete Set



Frizione
Antisaltemento
Slipper Clutches



Carter Frizione
Clutch Covers

SUZUKI	CC	MY	COD	PAG	COD	PAG	COD	PAG	COD	PAG	COD	PAG	COD	PAG
GSX ESD/EFE/ESG	750	83	86	SU-20	157									
GSX ET/EX	750	80	81	SU-20	157									
GSX R F/G/XH	750	85	87	SU-29	158									
GSX R K1-K2-K3	750	01	03	SU-64	160									
GSX R K4-K5	750	04	05	SU-64	160									
GSX R K6-K10	750	06	10											
GSX R K6-K7	750	06	07	SU-64	160									
GSX R SRAD	750	04	05											
GSX R SRAD	750	06												
GSX R WR/WS	750	94	95											
GSX R Y/K1	750	00	01											
GSX R-WT-W	750	96	99	SU-64	160									
GSX SE KATANA	750	84		SU-20	157									
GSX W/X/Y/K1 PINZA SINISTRA	750	98	03	SU-32	158									
VS GL ALL MODELS	750	85	90	SU-58	159									
DR SL	800	90		SU-73	161									
DR SM	800	91		SU-73	161									
VL K1-K4 INTRUDER VOLUSIA	800	01	04	SU-58	159									
VL K5/K6/K7 INTRUDER	800	05	07	SU-58	159									
VS GLN/GLP/GLR/GLS/GLV	800	92	97	SU-58	159									
VS K5 INTRUDER	800	05		SU-58	159									
VX L/M/N/P/R	800	90	96	SU-58	159									
VZ K5/K6/K7 M INTRUDER	800	05	07	SU-58	159									
VZ V/W/X/Y/K1-K4 MARAUDER	800	97	04	SU-58	159									
GS GN/GT/GX/GZ/GF/GG	850	79	85	SU-20	157									
RF RS/RS2/RT/RV/RW	900	95	99	SU-64	160									
DL K2-K7 V-STORM P. SX	1000	02	07											
GS GT/GX	1000	80	81	SU-33	159									
GS HC-EC-EN-SN-ET	1000	78	80	SU-21	157									
GSX R 1000	1000	03												
GSX R K1-K2	1000	01	02											
GSX R K3	1000	03												
GSX R K4	1000	04												
GSX R K5-K6	1000	05	06											
GSX R K7	1000	07												
GSX SZ KATANA	1000	82		SU-33	159									
SV K3-K8/SK3-SK8	1000	03	08											
TL RK1	1000	01	02											
TL RW/RX/SX/RV/SY	1000	98	00											
TL SK1	1000	01	02											
TL SV/SW	1000	97	98	SU-64	160									
GS GZ KATANA	1100	82		SU-33	159									
GSX EFE-EFG	1100	84	88	SU-33	159									
GSX ET-EX-EZ	1100	80	81	SU-33	159									
GSX SZ	1100	82		SU-33	159									
GS SS	1200	01		SU-64	160									
GSF BANDIT	1200	96	00	SU-64	160									
GSF BANDIT S	1200	01	05	SU-64	160									
GSF SAK6/AK6/GTSAK6	1200	06		SU-64	160									
GSX INAZUMA FSW/FSX	1200	98	99	SU-64	160									
GSF AK7/ASK7 BANDIT	1250	07												
B-KING	1300	07												
GSX 1300 B KING	1300	07												
GSX 1300 B KING	1300	08												
GSX RK2/RZK3/RK4-RK5 /K6/K7	1300	02	07											
GSX RX/RV/RK1 HAYABUSA	1300	99	01											
GSX K1-K7	1400	01	07											
VS INTRUDER	1400	87	03	SU-81	161									
VL K2-K3 INTRUDER LC	1500	02	03	SU-33	159									
VL K5-K6-K7 INTRUDER LC	1500	05	07	SU-33	159									

FRENI - BRAKES

VALVOLE - REEDS

COLLETTORI INTAKE MANIFOLDS

FERMACOPERTONI TIRE LOCKS

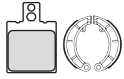

Pastiglie/Ganasce Anteriori
Front Brake Pads/Shoes

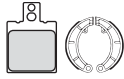

Pastiglie/Ganasce Posteriori
Rear Brake Pads/Shoes



Dischi Freno Anteriore
Front Brake Disk



Dischi Freno Posteriori
Rear Brake Disk



Lamelle
Reeds



Valvole Lamellari
Reed Valve



Valvola Power Reed
Power Reed Valve



Collettori Aspirazione
Intake Manifolds



Fermacopertoni Anteriore
Front Tire Locks



Fermacopertoni Posteriori
Rear Tire Locks

COD	PAG	COD	PAG	COD	PAG	COD	PAG	COD	PAG	COD	PAG	COD	PAG	COD	PAG	COD	PAG	COD	PAG
		P.111	225																
P.107	224	P.111	225																
P.215	258	P.218	259																
P.215	258	P.223	260																
		P.218	259																
P.215	258	P.223	260																
P.161	234	P.111	225																
P.107	224	P.111	225																
P.161	234	P.111	225																
P.169	237	P.111	225																
		P.116	226																
P.171	238																		
P.171	238																		
P.171	238																		
P.169	237																		
P.171	238																		
P.171	238																		
P.095	222	P.111	225																
P.169	237	P.134	228																
P.232	264																		
P.161	234	P.218	259																
		P.218	259																
P.215	258	P.218	259																
P.215	258	P.218	259																
P.215	258	P.223	260																
P.107	224	P.134	228																
P.161	234	P.111	225																
P.107	224	P.111	225																
P.107	224	P.111	225																
P.107	224	P.111	225																
P.161	234	P.218	259																
P.095	222	P.111	225																
P.161	234	P.111	225																
P.107	224	P.134	228																
P.168	236	P.111	225																
P.107	224	P.134	228																
		P.134	228																
P.268	281																		
P.234	265																		
P.161	234	P.111	225																
P.161	234	P.111	225																
P.161	234	P.218	259																
P.169	237																		
P.169	237	P.171	238																

MARCA - MODELLO MAKE - MODEL



Serie
Dischi Rivestiti
Friction Plate Kit



RACING
Serie
Dischi Rivestiti
Friction Plate Kit



Serie Completa
Dischi Frizione
Clutch Plates
Complete Set



RACING
Serie Completa
Dischi Frizione
Clutch Plates
Complete Set



Frizione
Antisaltemento
Slipper Clutches



Carter Frizione
Clutch Covers

SUZUKI	CC	MY	COD	PAG	COD	PAG	COD	PAG	COD	PAG	COD	PAG	COD	PAG
VL W/X/Y/K1 INTRUDER LC	1500	98	01	SU-33	159									
M 1600 INTRUDER	1600	05												
TL S	1600	97	00											
VZ K4 MARAUDER	1600	04												
VZ K5 INTRUDER	1600	05												
VZR INTRUDER	1800	06												
SWM	CC	MY												
XP 350 SAHARA	350	83												
SYM	CC	MY												
FIDDLE	50	99												
JET	50	99												
JUNGLE	50	99												
MUSK L.C.	50	99												
RED DEVIL	50	99												
RS 21 50	50	02												
SUPER FANCY	50	99												
JET	100	99												
SUPER FANCY	100	99												
ATTILA	125	99												
EURO 125 MX	125	03												
HD	125	04												
HD 125	125	05												
HD 125 EVO EURO3	125	10												
HD2 125 EVO	125	14												
HS	125	04												
HUSKY	125	96	98											
JOY RIDE 125 EURO 2	125	05												
JOY RIDE 125 EURO 3	125	07												
JOYRIDE	125	01												
MEGALO	125	02												
RS 125	125	05												
RS 21 125	125	02												
SHARK	125	99												
SHARK 125	125	00												
SUPER DUKE	125	99												
VOYAGER	125	05												
WOLF LEGEND	125	02												
EURO 150 MX	150	03												
JOY RIDE 150	150	01												
JOYRIDE	150	01												
RS 150	150	05												
VOYAGER	150	05												
HD	200	04												
HD 200 EVO EURO 2	200	05												
HD 200 EVO I EURO 3	200	10												
HD2 200 EVO	200	14												
HS	200	04												
JOY RIDE 200	200	01												
JOY RIDE 200 I EURO 3	200	07												
JOY RIDE 200 I EVO	200	10												
JOYRIDE	200	01												
GTS 250	250	07												
RV	250	07												
JOY MAX 300 EVO	300	09												
JOY MAX 300 EVO I	300	10												
MAXSYM 400 I	400	11												
GT	500	04												
SYM ATV	CC	MY												
TRACK RUNNER 180	180	06												
QUAD LANDER 250	250	06												

FRENI - BRAKES

VALVOLE - REEDS

COLLETTORI INTAKE MANIFOLDS

FERMACOPERTONI TIRE LOCKS

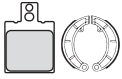

Pastiglie/Ganasce Anteriori
Front Brake Pads/Shoes

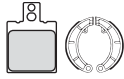

Pastiglie/Ganasce Posteriori
Rear Brake Pads/Shoes



Dischi Freno Anteriore
Front Brake Disk



Dischi Freno Posteriori
Rear Brake Disk



Lamelle
Reeds



Valvole Lamellari
Reed Valve



Valvola Power Reed
Power Reed Valve



Collettori Aspirazione
Intake Manifolds



Fermacopertoni Anteriore
Front Tire Locks



Fermacopertoni Posteriori
Rear Tire Locks

COD	PAG	COD	PAG	COD	PAG	COD	PAG	COD	PAG	COD	PAG	COD	PAG	COD	PAG	COD	PAG	COD	PAG
P.232	264																		
P.107	224	P.111	225																
P.161	234	P.171	238																
		P.171	238																
P.215	258																		
P.245	270																		
01200	288	01200	288																
P.188	245	01200	288																
P.188	245	01200	288																
P.188	245	01200	288																
P.188	245	01200	288																
P.250	273																		
		01200	288																
		01200	288																
		01200	288																
P.188	245	01200	288																
P.250	273																		
P.210	256																		
		P.263	279																
		P.263	279																
		P.263	279																
P.210	256																		
P.075	217																		
		P.263	279																
		P.263	279																
		P.210	256																
P.188	245																		
P.250	273																		
P.250	273																		
P.188	245																		
P.188	245																		
P.188	245	01200	288																
P.195	248																		
P.073	216																		
P.250	273																		
P.250	273																		
		P.210	256																
P.250	273																		
P.195	248																		
P.210	256																		
		P.263	279																
		P.263	279																
		P.263	279																
P.210	256																		
P.250	273																		
		P.263	279																
		P.263	279																
		P.210	256																
		P.263	279																
P.183	242																		
		P.263	279																
		P.263	279																
P.262	279																		
P.183	242																		
		P.263	279																
		P.263	279																

MARCA - MODELLO MAKE - MODEL



Serie
Dischi Rivestiti
Friction Plate Kit



RACING
Serie
Dischi Rivestiti
Friction Plate Kit



Serie Completa
Dischi Frizione
Clutch Plates
Complete Set



RACING
Serie Completa
Dischi Frizione
Clutch Plates
Complete Set



Frizione
Antisaltemento
Slipper Clutches



Carter Frizione
Clutch Covers

TGB	CC	MY	COD	PAG	COD	PAG	COD	PAG	COD	PAG	COD	PAG	COD	PAG
BUNNY	0	97												
DOUBLE X	0	05												
203 50	50	02												
203 50	50	05												
303 R 50	50	99												
AKROS 50	50	99												
AKROS 50 TEC 5	50	99												
APOLLO 50	50	99												
ERGON 50	50	96												
FIRE 50	50	03												
HIWS 50	50	99												
SKY 50	50	03												
TRIGGER 50	50	99												
101 S 90	90	99												
202 S 90	90	99												
AKROS 90	90	99												
APOLLO 90	90	99												
ERGON 90	90	99												
HIWS 90	90	99												
TRIGGER 90	90	99												
101 S 125	125	99												
202 T 125	125	99												
303 R 125	125	99												
309 RACING	309	05												
309 RS	309	00												
507	507	05												
TM	CC	MY												
JUNIOR 80	80	96												
TOMOS	CC	MY												
REVIVAL	50	03												
STREETMATE	50	03	04											
STREETMATE	50	05												
TS	50	03												
TRIUMPH	CC	MY												
DAYTONA	600	03	04	HO-134	147									
SPEED FOUR	600	03		HO-134	147									
TT	600	00	03	HO-134	147									
DAYTONA	650	05		HO-134	147									
DAYTONA 675	675	06												
STREET TRIPLE R 675	675	09												
STREET TRIPLE R 675	675	09												
STREET TRIPLE R 675	675	13												
STREET TRIPLE RX 675	675	15												
BONNEVILLE 750 UK	750	87												
DAYTONA SPORT	750	91												
AMERICA	800	03	06											
BONNEVILLE	800	01	04											
BONNEVILLE AMERICA	800	02												
BONNEVILLE T100 CE	800	02	04											
BONNEVILLE T100 P. SMITH	800	06												
SPEEDMASTER	800	03	06											
AMERICA	900	07												
DAYTONA	900	93												
DAYTONA T 595	900	97												
SCRAMBLER	900	06												
SPEEDMASTER	900	07												
THRUXTON	900	04												
TRIDENT SPRINT	900	95												
DAYTONA	955	99	00	HO-145	147									
DAYTONA	955	01	04	HO-145	147									

MARCA - MODELLO MAKE - MODEL



Serie
Dischi Rivestiti
Friction Plate Kit



RACING
Serie
Dischi Rivestiti
Friction Plate Kit



Serie Completa
Dischi Frizione
Clutch Plates
Complete Set



RACING
Serie Completa
Dischi Frizione
Clutch Plates
Complete Set



Frizione
Antisaltemento
Slipper Clutches



Carter Frizione
Clutch Covers

TRIUMPH	CC	MY	COD	PAG	COD	PAG	COD	PAG	COD	PAG	COD	PAG	COD	PAG
DAYTONA I.E.	955	05	HO-145	147										
SPEED TRIPLE	955	99	HO-145	147										
SPRINT RS	955	00												
SPRINT ST	955	99	04											
TIGER	955	01	04											
TIGER	955	05												
SPEED TRIPLE T 509	995	99	04	HO-145	147									
SPEED TRIPLE	1050	05	07											
SPEED TRIPLE	1050	08												
SPEED TRIPLE 1050	1050	05												
SPRINT ST	1050	05												
TIGER 1050	1050	07												
TIGER SE 1050	1050	09												
TIGER SPORT	1050	15												
DAYTONA SPORT	1100	91												
TROPHY	1200	93	03											
ROCKET III	2300	04												
UVM	CC	MY												
BE THERE 50	50	99												
BE THERE 125	125	99												
BINGO 125	125	99												
PARAGON 125	125	99												
VERTEMATI	CC	MY												
492 ENDURO	500	99												
492 SUPERMOTARD	500	99												
495 CROSS	500	99												
C	500	01												
VESPA	CC	MY												
VESPA	50		63											
VESPA ET2	50	99												
VESPA ET4 (G)	50	01												
VESPA ET4 (H)	50	01												
VESPA LX 2T	50	05												
VESPA LX 4T	50	05												
VESPA PK SPECIAL-XL	50			VE-160	162			VE-346	190	VE-247	190			
VESPA SPECIAL	50			VE-160	162			VE-346	190	VE-247	190			
VESPA PRIMAVERA	90			VE-160	162			VE-346	190	VE-247	190			
VESPA	125	51	62							VE-247	190			
VESPA	125	63	72							VE-247	190			
VESPA ET3	125			VE-160	162			VE-346	190	VE-247	190			
VESPA ET4	125	97	99											
VESPA ET4	125	00												
VESPA GRANTURISMO L (H)	125	03												
VESPA LX	125	05	07											
VESPA PK AUTOMATICA	125	86		VE-160	162			VE-346	190	VE-247	190			
VESPA PK SPECIAL-XL	125			VE-160	162			VE-346	190	VE-247	190			
VESPA PK XL 2	125			VE-160	162			VE-346	190	VE-247	190			
VESPA PRIMAVERA	125	80		VE-160	162			VE-346	190	VE-247	190			
VESPA PX	125	98												
VESPA PX	125			VE-155	162									
VESPA V FL2	125	90												
VESPA	150	51	62											
VESPA	150	63	72											
VESPA ET4	150	99												
VESPA LX	150	05	07											
VESPA LXV	150	05	08											
VESPA PX	150	78		VE-155	162									
VESPA PX	150	98		VE-362	163			VE-364	191					
VESPA PX ARCOBALENO	150	83		VE-155	162									
VESPA SPRINT VELOCE	150			VE-155	162									

FRENI - BRAKES

VALVOLE - REEDS

COLLETTORI INTAKE MANIFOLDS

FERMACOPERTONI TIRE LOCKS

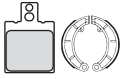

Pastiglie/Ganasce Anteriore
Front Brake Pads/Shoes

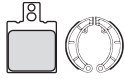

Pastiglie/Ganasce Posteriore
Rear Brake Pads/Shoes



Dischi Freno Anteriore
Front Brake Disk



Dischi Freno Posteriore
Rear Brake Disk



Lamelle
Reeds



Valvole Lamellari
Reed Valve



Valvola Power Reed
Power Reed Valve



Collettori Aspirazione
Intake Manifolds



Fermacopertoni Anteriore
Front Tire Locks



Fermacopertoni Posteriore
Rear Tire Locks

COD	PAG	COD	PAG	COD	PAG	COD	PAG	COD	PAG	COD	PAG	COD	PAG	COD	PAG	COD	PAG	COD	PAG
P.095	222	P.086	220																
P.095	222	P.086	220																
P.095	222																		
P.095	222	P.086	220																
		P.156	232																
		P.116	226																
P.095	222	P.086	220																
P.234	265	P.086	220																
P.211	256																		
P.234	265																		
P.095	222	P.086	220																
P.234	265	P.116	226																
P.234	265																		
P.234	265																		
P.095	222																		
P.095	222	P.086	220																
		P.192	247																
P.260	277																		
P.260	277																		
P.260	277																		
P.260	277																		
P.143	230	P.172	238																
P.067	214	P.172	238																
P.143	230	P.172	238																
P.143	230	P.172	238																
0162	285	0130	284																
P.175	240	01284	289	DF-10	296			83	314					VE-371	329				
P.175	240	01284	289	DF-10	296														
P.204	253	01284	289	DF-10	296														
P.175	240	01284	289																
P.175	240	01284	289																
0162	285	0161	285																
0162	285	0159	284																
0162	285																		
0162	285																		
0162	285	0159	284																
P.175	240	01284	289	DF-10	296														
P.175	240	01284	289	DF-10	296														
P.158	233	P.193	247																
P.175	240	01284	289																
0161	285	0161	285																
0161	285	0161	285																
0161	285	0161	285																
0162	285	0159	284																
P.144	231	0161	285																
0161	285	0161	285																
0161	285	0161	285																
0162	285																		
0162	285																		
P.175	240			DF-10	296														
P.175	240	01284	289																
P.175	240	01284	289																
0161	285	0161	285																
		0161	285	DF-10	296														
024	284	0161	285																

MARCA - MODELLO MAKE - MODEL



Serie
Dischi Rivestiti
Friction Plate Kit



RACING
Serie
Dischi Rivestiti
Friction Plate Kit



Serie Completa
Dischi Frizione
Clutch Plates
Complete Set



RACING
Serie Completa
Dischi Frizione
Clutch Plates
Complete Set



Frizione
Antisaltemento
Slipper Clutches



Carter Frizione
Clutch Covers

VESPA	CC	MY	COD	PAG	COD	PAG	COD	PAG	COD	PAG	COD	PAG	COD	PAG
VESPA SUPER	150		VE-155	162										
VESPA GS	160		VE-121	162										
VESPA SS	180		VE-121	162										
VESPA PE	200	83	VE-121	162										
VESPA PX	200	98	VE-362	163			VE-364	191						
VESPA PX ARCOBALENO	200	83	VE-121	162										
VESPA PX E	200	78	VE-121	162										
VESPA RALLY	200	87	VE-121	162										
VESPA GT60	250	06												
VESPA GTE	250	05												
VESPA GTS	250	05	07											
VESPA GTV	250	07												
GTS SUPER	300	08												
VICTORY	CC	MY												
8-BALL	1500	05												
ARLEN NESS	1500	04												
HAMMER	1500	05												
HAMMER S	1500	07												
KING PIN	1500	04												
KING PIN TOUR	1500	07												
TOURING CRUISER	1500	03												
V92C CRUISER	1500	98	02											
V92C DELUXE	1500	01	02											
V92SC SPORT CRUISER	1500	00	02											
VEGAS	1500	03												
VEGAS JACKPOT	1500	06												
VILLA	CC	MY												
GZ	50	93												
VOR	CC	MY												
MX	350	01												
ENDURO	400	00												
492 ENDURO	500	99												
492 SUPERMOTARD	500	00												
495 CROSS	500	99												
ENDURO	530	01												
VOXAN	CC	MY												
CAFE RACER	1000	01												
ROADSTER	1000	01												
SCRAMBLER	1000	01	03											
VB1 EVO	1000	04												
YAMAHA	CC	MY												
AEROX	50	97												
AXIS	50	94												
BREEZE	50	95												
BW'S	50	91	92											
BW'S BUMP	50	96												
BW'S N.G.	50	96												
BW'S R	50	95												
BW'S SPY	50	96												
C3	50	07												
CRZ	50	92												
CW T ZUMA	50	02	05											
CW T ZUMA	50	89	90											
CW ZUMA	50	02	05											
CW ZUMA II	50	00	01											
CW ZUMA II	50	00	01											
DT MX	50	92	95											
DT R	50	97	01	FB-132	142	FB-132/M	142	FB-140	178	FB-140/C	178			
DT R	50	02	04	FB-132	142	FB-132/M	142	FB-140	178	FB-140/C	178			
DT R	50	04												

FRENI - BRAKES

VALVOLE - REEDS

COLLETTORI INTAKE MANIFOLDS

FERMACOPERTONI TIRE LOCKS

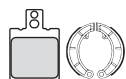

Pastiglie/Ganasce Anteriori
Front Brake Pads/Shoes

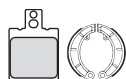

Pastiglie/Ganasce Posteriori
Rear Brake Pads/Shoes



Dischi Freno Anteriori
Front Brake Disk



Dischi Freno Posteriori
Rear Brake Disk



Lamelle
Reeds



Valvole Lamellari
Reed Valve



Valvola Power Reed
Power Reed Valve



Collettori Aspirazione
Intake Manifolds



Fermacopertoni Anteriori
Front Tire Locks



Fermacopertoni Posteriori
Rear Tire Locks

COD	PAG	COD	PAG	COD	PAG	COD	PAG	COD	PAG	COD	PAG	COD	PAG	COD	PAG	COD	PAG	COD	PAG
0162	285																		
024	284	0161	285																
		0161	285																
0161	285	0161	285																
P.144	231	0161	285	DF-10	296														
0161	285	0161	285																
024	284	0161	285																
P.204	253	P.193	247																
P.204	253	P.212	257																
P.204	253	P.193	247																
P.204	253	P.193	247																
P.204	253	P.193	247																
P.168	236	P.192	247																
P.168	236	P.192	247																
P.168	236	P.192	247																
P.168	236	P.192	247																
P.168	236	P.192	247																
P.168	236	P.192	247																
P.168	236	P.192	247																
P.168	236	P.192	247																
P.168	236	P.192	247																
P.168	236	P.192	247																
P.168	236	P.192	247																
		01200	288	DF-12	297														
P.143	230	P.172	238																
P.143	230	P.172	238																
P.143	230	P.172	238																
P.067	214	P.172	238																
P.143	230	P.172	238																
P.143	230	P.172	238																
P.067	214	P.186	244																
P.067	214	P.186	244																
P.108	224																		
P.168	236	P.186	244																
P.173	240	P.176	241	DF-5	293	DF-5	293	98	315	FB-146	319			FB-135	328				
P.141	229	01200	288	DF-12	297			77	314					FB-134	327				
P.139	228			DF-12	297			77	314					FB-134	327				
								77	314					FB-134	327				
P.173	240			DF-7	294			77	314					FB-134	327				
P.139	228							77	314					FB-134	327				
P.173	240							77	314					FB-134	327				
P.139	228			DF-7	294			77	314					FB-134	327				
01205	288	01205	288					98	315	FB-146	319			FB-135	328				
P.141	229	01205	288	DF-12	297			77	314					FB-134	327				
P.141	229							77	314					FB-134	327				
								77	314					FB-134	327				
P.139	228							77	314					FB-134	327				
01205	288	01205	288																
P.098	222	01205	288																
P.098	222	P.065	213																
P.158	233	P.065	213																

MARCA - MODELLO MAKE - MODEL



Serie
Dischi Rivestiti
Friction Plate Kit



RACING
Serie
Dischi Rivestiti
Friction Plate Kit



Serie Completa
Dischi Frizione
Clutch Plates
Complete Set



RACING
Serie Completa
Dischi Frizione
Clutch Plates
Complete Set



Frizione
Antisaltemento
Slipper Clutches



Carter Frizione
Clutch Covers

YAMAHA	CC	MY	COD	PAG	COD	PAG	COD	PAG	COD	PAG	COD	PAG	COD	PAG
DT X SUPERMOTARD	50	04												
JOG	50	88	91											
JOG	50	92												
JOG R	50	94												
NEO'S	50	97												
SLIDER	50	00												
SPY	50	95												
TZR	50	03	04											
TZR THUNDERKID	50	97	00											
WHY	50	98												
ZUMA	50	05	08											
G/H/J/K/L/M/N	80	95	01											
RD	80	82	85											
RD LC	80	82	84											
TZR RR	80	89	97											
YZ	80	97	02											
YZ E/LC/LW/F	80	93	94											
YZ	85	02	07											
TT-R	90	00	07											
AEROX	100	00												
BW'S	100	00												
NEO'S	100	00												
RT E/F/K	100	93	03											
YB	100	82	86											
YB	100	87	92											
CYGNUS R	125	96	02											
CYGNUS X	125	03												
DT 125	125	84												
DT LC TYPE 35A	125	85	87											
DT R	125	88	03	FB-127	141			FB-139	177					
DT RE	125	04		FB-127	141			FB-139	177					
DT RE	125	05	07	FB-127	141			FB-139	177					
DT X	125	05		FB-127	141			FB-139	177					
HW 125 XENTER	125	12												
MAJESTY SP	125	98	00											
MAJESTY SP	125	01												
MAXSTER	125	01												
MT 125	125	14												
NXC 125 CYGNUS	125	10												
R1 125YZF 125 R	125	08												
RD LC (MK1-MK3)	125	82	84											
TDR	125	89	92	FB-127	141			FB-139	177					
TDR R	125	93	03	FB-127	141			FB-139	177					
TEO'S	125	01												
TT-R	125	00	07											
TT-R L	125	00	07											
TZR	125	90	92											
TZR	125	87	89											
TZR	125	93		FB-127	141			FB-139	177					
TZR RR	125	94		FB-127	141			FB-139	177					
VINO	125	04												
X-CITY	125	08												
X-MAX	125	06												
X-MAX	125	10												
XC 125 VITY	125	08												
XT R	125	05	07											
XT X	125	05	07											
XTZ K/E	125	05	06											
XV VIRAGO	125	97	00	YA-110	166									
XVS DRAG STAR	125	00	04	YA-110	166									

FRENI - BRAKES

VALVOLE - REEDS

COLLETTORI INTAKE MANIFOLDS

FERMACOPERTONI TIRE LOCKS

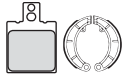

Pastiglie/Ganasce Anteriore
Front Brake Pads/Shoes

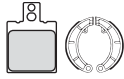

Pastiglie/Ganasce Posteriori
Rear Brake Pads/Shoes



Dischi Freno Anteriore
Front Brake Disk



Dischi Freno Posteriori
Rear Brake Disk



Lamelle
Reeds



Valvole Lamellari
Reed Valve



Valvola Power Reed
Power Reed Valve



Collettori Aspirazione
Intake Manifolds



Fermacopertoni Anteriore
Front Tire Locks



Fermacopertoni Posteriori
Rear Tire Locks

COD	PAG	COD	PAG	COD	PAG	COD	PAG	COD	PAG	COD	PAG	COD	PAG	COD	PAG	COD	PAG	COD	PAG
P.158	233	P.065	213																
								77	314					FB-134	327				
P.173	240	01200	288					77	314					FB-134	327				
P.173	240	01200	288					77	314					FB-134	327				
P.173	240							98	315	FB-146	319			FB-135	328				
P.176	241			DF-5	293			98	315	FB-146	319			FB-135	328				
P.139	228	01205	288	DF-7	294			77	314					FB-134	327				
P.158	233	P.065	213																
P.166	235	P.079	218																
P.139	228							98	315	FB-146	319			FB-135	328				
								98	315	FB-146	319			FB-135	328				
		P.076	218																
								24	312	YA-38	321								
								24	312	YA-38	321								
		P.079	218																
		P.076	218																
		P.076	218																
		P.076	218																
		01205	288																
P.173	240	P.176	241	DF-5	293	DF-5	293	98	315	FB-146	319			FB-135	328				
P.139	228							98	315	FB-146	319			FB-135	328				
P.173	240			DF-1	292			98	315	FB-146	319			FB-135	328				
01205	288	01205	288																
		01205	288																
01205	288	01205	288																
P.079	218	01205	288																
P.116	226	01205	288																
P.260	277																		
								10	310										
P.079	218	P.079	218					10	310										
P.079	218	P.079	218																
P.079	218	P.114	225																
P.192	247	P.114	225																
P.248	272																		
P.143	230			DF-32	304														
P.143	230	P.186	244	DF-32	304														
P.143	230	P.186	244																
P.262	279	P.240	268																
P.254	275																		
		P.240	268																
								10	310										
										FB-128	318								
P.150	232	P.079	218							FB-128	318								
P.139	228																		
01205	288	01205	288																
		01205	288																
P.057	211							38	313										
								38	313										
P.177	241							38	313										
P.067	214	P.012	208																
P.079	218																		
		P.180	242																
P.214	258	P.180	242	DF-35	305														
		P.180	242																
P.253	275																		
P.201	251	P.201	251																
P.158	233	P.201	251																
P.166	235																		
P.165	235																		
P.165	235																		

MARCA - MODELLO MAKE - MODEL



Serie
Dischi Rivestiti
Friction Plate Kit



RACING
Serie
Dischi Rivestiti
Friction Plate Kit



Serie Completa
Dischi Frizione
Clutch Plates
Complete Set



RACING
Serie Completa
Dischi Frizione
Clutch Plates
Complete Set



Frizione
Antisaltemento
Slipper Clutches



Carter Frizione
Clutch Covers

YAMAHA	CC	MY	COD	PAG	COD	PAG	COD	PAG	COD	PAG	COD	PAG	COD	PAG
YBR 125 ED	125	07												
YJ 125 S/T/V/W/X VINO	125	04	08											
YW 125 BWS	125	10												
YZ 125	125	08												
YZ A/B	125	90	92											
YZ B/D/E/F/G/H/J	125	93	97											
YZ K/L	125	83	84											
YZ K/L/M/N/P	125	98	02											
YZ R/S/T/V/W	125	03	07											
YZ U	125	88												
YZ W	125	89												
YZFR 125	125	14												
CRYPTON	135	06												
HW 150 XENTER	150	12												
MAJESTY 4T	150	99												
MAXSTER	150	01												
TEO'S	150	01												
TZR R	150	00	FB-127	141			FB-139	177						
MAJESTY SP	180	03												
WR D/E/F	200	92	94	FB-127	141		FB-139	177						
YFM N	200	86	90											
YFS B/F-H/J-N/P/R-T	200	91	02	FB-127	141		FB-139	177						
YFS R/S/T	200	03	05	FB-127	141		FB-139	177						
XT	225	01	07											
YFM DRN	225	85												
YFM N/S/T/U	225	85	89											
DT	250	75	76	YA-43	164		YA-70	191						
IT G	250	80		YA-30	164									
IT H/J	250	81	82	YA-25	163									
MAJESTY DE-LUXE	250	98	00											
MAJESTY YP	250	01	03											
MAJESTY YP	250	04												
MORPHOUS	250	05												
R1 250 Z	250	90												
RD A-F	250	74	79	YA-43	164		YA-70	191						
RD LC	250	80	82	YA-43	164		YA-70	191						
SR	250	93	98	YA-78	165									
SR SE	250	81	82	YA-78	165									
TDR	250	88	92											
TDR 250	250	88												
TT RH/RL	250	96	99											
TY D/E	250	77	78	YA-43	164		YA-70	191						
TY R	250	91	92											
TY R	250	93	94											
TZ 250	250	85												
TZ 250 COMPETITION	250	88												
TZR	250	87	92											
TZR 250	250	85												
TZR R	250	91												
WR FN/FP/FR/FS/FT	250	00	02											
WR FN/FP/FR/FS/FT/FV/FW	250	03	07											
WR ZB/ZD/ZE	250	91	93											
WR ZF/ZG/ZH/ZJ	250	94	97											
WR ZK	250	98												
X-CITY	250	07												
X-MAX	250	04	09											
X-MAX	250	10												
XS	250	78	80	YA-25	163									
XS SE-C	250	80	81	YA-30	164									
XV S VIRAGO	250	95	00	YA-110	166									

FRENI - BRAKES

VALVOLE - REEDS

COLLETTORI INTAKE MANIFOLDS

FERMACOPERTONI TIRE LOCKS

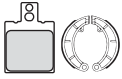

Pastiglie/Ganasce Anteriori
Front Brake Pads/Shoes

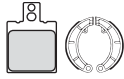

Pastiglie/Ganasce Posteriori
Rear Brake Pads/Shoes



Dischi Freno Anteriore
Front Brake Disk



Dischi Freno Posteriori
Rear Brake Disk



Lamelle
Reeds



Valvole Lamellari
Reed Valve



Valvola Power Reed
Power Reed Valve



Collettori Aspirazione
Intake Manifolds



Fermacopertoni Anteriore
Front Tire Locks



Fermacopertoni Posteriori
Rear Tire Locks

COD	PAG	COD	PAG	COD	PAG	COD	PAG	COD	PAG	COD	PAG	COD	PAG	COD	PAG	COD	PAG	COD	PAG
P.253	275																		
P.079	218																		
P.248	272																		
P.267	281																		
P.086	220	P.114	225																
P.086	220	P.114	225																
P.190	246	P.093	221																
P.190	246	P.205	253																
		P.079	218																
P.086	220	P.076	218																
P.262	279	P.240	268																
P.253	275																		
P.248	272																		
P.143	230	P.186	244	DF-32	304														
P.143	230	P.186	244																
P.139	228																		
P.165	235																		
P.143	230	P.186	244	DF-32	304														
P.086	220	P.114	225																
01205	288																		
01205	288																		
		P.076	218																
P.180	242	01205	288																
01205	288																		
01205	288																		
										13	311								
P.165	235	P.180	242	DF-11	296														
		P.180	242	DF-11	296	DF-33	304												
P.165	235	P.213	257			DF-36	305												
P.150	232	P.213	257																
P.242	269																		
P.087	221																		
P.242	269																		
P.086	220	P.114	225																
P.065	213																		
P.065	213	P.065	213																
P.242	269																		
P.242	269																		
P.177	241																		
P.242	269																		
P.177	241																		
P.190	246	P.093	221																
P.190	246	P.205	253																
P.086	220	P.114	225																
P.086	220	P.114	225																
P.190	246	P.093	221																
		P.180	242																
P.214	258	P.180	242	DF-35	305														
		P.180	242																
P.087	221																		
P.165	235																		

MARCA - MODELLO MAKE - MODEL



Serie
Dischi Rivestiti
Friction Plate Kit



RACING
Serie
Dischi Rivestiti
Friction Plate Kit



Serie Completa
Dischi Frizione
Clutch Plates
Complete Set



RACING
Serie Completa
Dischi Frizione
Clutch Plates
Complete Set



Frizione
Antisaltemento
Slipper Clutches



Carter Frizione
Clutch Covers

YAMAHA	CC	MY	COD	PAG	COD	PAG	COD	PAG	COD	PAG	COD	PAG	COD	PAG
XV VIRAGO	250	89	94	YA-110	166									
XVS DRAG STAR	250	01	04	YA-30	164									
YP R 250 XMAX	250	14												
YZ 250	250	08												
YZ E/F/G/H/J 2T	250	93	97											
YZ F	250	79		YA-30	164									
YZ F 250	250	07												
YZ F 250 EFI	250	14												
YZ FN/FP/FR/FS/FT	250	01	02											
YZ FX 250 EFI	250	15												
YZ H	250	81		YA-25	163									
YZ K/L/M 2T	250	98	03											
YZ R/S/T/V/W	250	03	07											
YZ U	250	88												
YZ W/WRW	250	89	92											
VERSITY	300	03												
RD A/B	350	74	75	YA-43	164			YA-70	191					
RD LC	350	80	82	YA-43	164			YA-70	191					
RD N/F/F2/R	350	85	95	YA-43	164			YA-70	191					
RD YPVS	350	83	84	YA-43	164			YA-70	191					
TT A (3GJ)	350	90	95	YA-43	164			YA-70	191					
XT	350	85	95	YA-43	164			YA-70	191					
YFM FWH/FWJ/FWK BIG BEAR	350	96	98	YA-98	166									
YFM FWT/FWU BIG BEAR	350	87	88	YA-98	166									
YFM FWW/FWA/FWB/FWD/FWE/FWF	350	89	95	YA-98	166									
YFM S/T RAPTOR	350	04	05	YA-98	166									
YFM XD-XS	350	92	04	YA-98	166									
YFZ U/A/B/D-N/P/R-T	350	90	05	YA-43	164			YA-70	191					
DT	400	75	76	YA-43	164			YA-70	191					
DT MX	400	77	79	YA-98	166									
FZR 400 R	400	87												
FZR GENESIS	400	86												
FZR RR (4DX)	400	92												
FZR RSP (2TK-EXUP)	400	87		YA-79	165									
MAJESTY S / T	400	04												
MAJESTY T / V / W	400	05												
RD C/D/E/F	400	76	79	YA-43	164			YA-70	191					
SRX (1JL)	400	87		YA-42	164									
SRX (3VN1/3VN2/3VN5)	400	90	96	YA-25	163									
SRX 400	400	87												
WR FK	400	98												
WR FL/FM/FN	400	99	01											
XJR R	400	95	96	YA-26	163									
XJR R	400	97	00	YA-26	163									
XJR R	400	01												
XS	400	78	79	YA-25	163									
XS SE	400	80		YA-25	163									
XVS	400	96	99											
YFM FPR/FPS BIG BEAR	400	03	04	YA-98	166									
YFM FWE/FWF/FWG/FWH/FWJ/FWK	400	93	00	YA-98	166									
YZ D/E/F	400	77	79	YA-25	163									
YZ FK	400	98												
YZ FL	400	99												
IT G	425	80	82	YA-25	163									
WR FN/FP	426	01	02											
YZ FM	426	00												
YZ FN/FP	426	01	02											
WR FR/FS	450	03	05									YA-121	201	YA-123 205
WR FT	450	06										YA-121	201	YA-123 205
WR FT	450	07	09									YA-122	201	YA-123 205

FRENI - BRAKES

VALVOLE - REEDS

COLLETTORI INTAKE MANIFOLDS

FERMACOPERTONI TIRE LOCKS

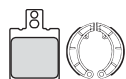

Pastiglie/Ganasce Anteriori
Front Brake Pads/Shoes

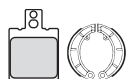

Pastiglie/Ganasce Posteriori
Rear Brake Pads/Shoes



Dischi Freno Anteriore
Front Brake Disk



Dischi Freno Posteriori
Rear Brake Disk



Lamelle
Reeds



Valvole Lamellari
Reed Valve



Valvola Power Reed
Power Reed Valve



Collettori Aspirazione
Intake Manifolds



Fermacopertoni Anteriore
Front Tire Locks



Fermacopertoni Posteriori
Rear Tire Locks

COD	PAG	COD	PAG	COD	PAG	COD	PAG	COD	PAG	COD	PAG	COD	PAG	COD	PAG	COD	PAG	COD	PAG
P.165	235																		
		P.251	274																
P.267	281																		
P.086	220	P.114	225																
P.267	281																		
P.267	281																		
P.190	246	P.205	253																
P.267	281																		
P.190	246	P.093	221																
P.190	246	P.205	253																
		P.079	218																
		P.114	225																
P.143	230	P.143	230																
		P.057	211																
P.079	218																		
P.076	218	P.076	218																
		P.076	218																
		P.076	218																
P.242	269																		
P.057	211																		
P.177	241																		
P.150	232	P.213	257	DF-34	304	DF-36	305												
P.165	235	P.213	257			DF-36	305												
P.087	221																		
P.242	269																		
		P.114	225					38	313										
P.190	246	P.093	221					38	313										
P.165	235	P.057	211																
P.168	236	P.057	211																
P.177	241																		
P.150	232																		
								38	313										
								38	313										
P.190	246	P.114	225																
P.190	246	P.093	221																
P.190	246	P.093	221																
P.190	246	P.093	221																
P.190	246	P.093	221																
P.190	246	P.205	253																
P.190	246	P.205	253																

MARCA - MODELLO MAKE - MODEL



Serie
Dischi Rivestiti
Friction Plate Kit



RACING
Serie
Dischi Rivestiti
Friction Plate Kit



Serie Completa
Dischi Frizione
Clutch Plates
Complete Set



RACING
Serie Completa
Dischi Frizione
Clutch Plates
Complete Set



Frizione
Antisaltemento
Slipper Clutches



Carter Frizione
Clutch Covers

YAMAHA	CC	MY	COD	PAG	COD	PAG	COD	PAG	COD	PAG	COD	PAG	COD	PAG
WR FT	450	07												
WR FT	450	10									YA-122	201	YA-125	205
YZ F 450	450	08												
YZ F 450 EFI	450	14												
YZ FR/FS	450	03	05								YA-121	201	YA-123	205
YZ FT	450	06									YA-121	201	YA-123	205
YZ FT	450	07												
YZ FT	450	07	09								YA-122	201	YA-123	205
YZ FT	450	10									YA-122	201	YA-125	205
IT H/J	465	81	82	YA-25	163									
YZ G	465	80		YA-25	163									
YZ H	465	81		YA-25	163									
RD LC YPVS	500	84	88											
SR	500	78	82											
T MAX	500	01	03											
T MAX	500	04	08											
T MAX	500	09	11											
T MAX BLACK MAX	500	06												
T MAX CUP	500	03												
T MAX SV	500	11												
XS B/C/D	500	77	79	YA-26	163									
XT	500	76	81											
XP T MAX	530	12												
XV S VIRAGO	535	95	03											
XJ	550	81	83	YA-35	164									
XT	550	83		YA-42	164									
FZ	600	87	88	YA-26	163									
FZ 6 FAZER	600	04	05	YA-26	163									
FZR	600	89		YA-79	165									
FZR R	600	90	93	YA-79	165									
FZR R	600	94	95											
FZS FAZER	600	98	03											
FZS FAZER SP	600	00	03											
SRX	600	86	87	YA-42	164									
SRX (1JK)	600	85	89	YA-42	164									
SRX (3SX)	600	90	91	YA-42	164									
SRX 600	600	87												
TT	600	84		YA-42	164									
TT E/R/S	600	93	02	YA-42	164									
TT RES	600	03	04	YA-42	164									
TT W	600	89	92	YA-42	164									
XJ	600	84	91	YA-26	163									
XJ N	600	95	97	YA-26	163									
XJ N	600	98	03	YA-26	163									
XJ S DIVERSION	600	92	97	YA-26	163									
XJ S DIVERSION	600	98	03	YA-26	163									
XT	600	87		YA-42	164									
XT	600	84	86	YA-42	164									
XT E/ZE	600	90	03	YA-42	164									
XT Z	600	84		YA-42	164									
XT Z	600	85	88	YA-42	164									
XT Z	600	89	90	YA-42	164									
YX S/SC/T/TC/UC/U/W/WC/A/AC	600	86	90	YA-26	163									
YZF R THUNDER CAT	600	96	03											
YZF R6	600	99	02	YA-26	163									
YZF R6	600	03	07	YA-26	163									
YZF R6 S	600	07												
LH MIDNIGHT	650	81		YA-26	163									
XJ	650	80	84	YA-26	163									
XJ G/H/J/K MAXIM	650	80	83	YA-26	163									

FRENI - BRAKES

VALVOLE - REEDS

COLLETTORI INTAKE MANIFOLDS

FERMACOPERTONI TIRE LOCKS

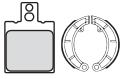

Pastiglie/Ganasce Anteriori
Front Brake Pads/Shoes

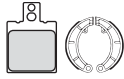

Pastiglie/Ganasce Posteriori
Rear Brake Pads/Shoes



Dischi Freno Anteriore
Front Brake Disk



Dischi Freno Posteriori
Rear Brake Disk



Lamelle
Reeds



Valvole Lamellari
Reed Valve



Valvola Power Reed
Power Reed Valve



Collettori Aspirazione
Intake Manifolds



Fermacopertoni Anteriore
Front Tire Locks



Fermacopertoni Posteriori
Rear Tire Locks

COD	PAG	COD	PAG	COD	PAG	COD	PAG	COD	PAG	COD	PAG	COD	PAG	COD	PAG	COD	PAG	COD	PAG
P.190	246																		
P.267	281																		
P.267	281																		
P.190	246																		
P.190	246	P.205	253																
P.190	246	P.203	252																
P.057	211																		
P.057	211	P.057	211																
P.150	232	P.197	249																
P.165	235	P.213	257																
P.177	241	P.213	257																
P.165	235	P.213	257			DF-42	307												
P.067	214	P.197	249																
P.177	241	P.197	249																
P.057	211																		
P.177	241	P.197	249																
P.150	232																		
P.057	211																		
P.165	235	P.134	228																
P.057	211	P.057	211																
		P.057	211																
		P.057	211																
P.177	241																		
P.177	241																		
P.087	221																		
P.242	269																		
P.143	230	P.114	225																
P.143	230	P.114	225																
P.057	211	P.057	211																
P.150	232																		
P.165	235																		
P.150	232																		
P.165	235																		
		P.079	218																
P.129	227	P.079	218																
		P.079	218																
P.057	211																		
P.177	241	P.057	211																
P.177	241																		
P.177	241																		
P.177	241	P.134	228																

MARCA - MODELLO MAKE - MODEL



Serie
Dischi Rivestiti
Friction Plate Kit



RACING
Serie
Dischi Rivestiti
Friction Plate Kit



Serie Completa
Dischi Frizione
Clutch Plates
Complete Set



RACING
Serie Completa
Dischi Frizione
Clutch Plates
Complete Set



Frizione
Antisaltemento
Slipper Clutches



Carter Frizione
Clutch Covers

YAMAHA	CC	MY	COD	PAG	COD	PAG	COD	PAG	COD	PAG	COD	PAG	COD	PAG
XJ LK SECA	650	83	YA-26	163										
XJ RJ SECA	650	82	YA-26	163										
XJ TURBO	650	82	YA-26	163										
XS	650	75	YA-9	163										
XVS DRAG STAR	650	97	04											
SZR	660	96	YA-42	164										
XT R	660	04	YA-42	164										
XT X SUPERMOTO	660	04	07											
XTZ TENERE	660	91	YA-42	164										
YFM R RAPTOR	660	01	YA-42	164										
FZX S/SC/T/TC FAZER	700	86	YA-26	163										
FZ	750	85	YA-26	163										
FZ	750	89	YA-35	164										
FZ	750	87	YA-35	164										
FZR GENESIS	750	87	YA-60	165										
FZR R OW01	750	89	YA-80	166										
FZX	750	87	YA-35	164										
XJ	750	82	YA-26	163										
XJ RF/RJ/RK SECA	750	81	YA-26	163										
XS	750	77	YA-25	163										
XS SE	750	79	YA-25	163										
XTZ SUPER TENERE P. SX	750	89	YA-26	163										
XV VIRAGO	750	92	97											
YZF 7R OW02	750	99	00											
YZF R/SP	750	93	YA-80	166										
TDM	850	91	YA-26	163										
TDM	850	96	YA-80	166										
TDM 850	850	91												
TRX	850	96	YA-80	166										
TDM 900	900	02												
TDM 900 A	900	05												
TDM AT/AV/AW (ABS)	900	05	YA-80	166										
TDM P/R/S/T/V	900	02	YA-80	166										
XJ	900	83	YA-26	163										
XJ F	900	85	YA-26	163										
XJ S DIVERSION	900	95	YA-26	163										
XVS 950 A MIDNIGHT STAR	950	09												
FZ1	1000	06												
FZR 1000 GENESIS EXUP	1000	86												
FZR EX UP	1000	89	90											
FZR GENESIS	1000	87	YA-60	165										
FZR R	1000	94												
FZS FAZER	1000	01	05											
GTS	1000	93	96											
XV VIRAGO	1000	86												
YZF THUNDER ACE	1000	96	02											
YZF R1	1000	98	YA-9	163										
YZF R1	1000	99	YA-101	166										
YZF R1	1000	02	YA-101	166										
YZF R1	1000	04	06											
YZF R1	1000	07												
BT BULLDOG P/R/S/T	1100	02	05											
FJ	1100	84	YA-75	165										
XV VIRAGO	1100	89	93											
XV VIRAGO	1100	94	98											
XV VIRAGO	1100	99	00											
XVS A DRAG STAR CLASSIC	1100	00	05											
XVS DRAG STAR	1100	99	04											
FJ	1200	86	YA-75	165										
FJ	1200	88	YA-75	165										

FRENI - BRAKES

VALVOLE - REEDS

COLLETTORI INTAKE MANIFOLDS

FERMACOPERTONI TIRE LOCKS

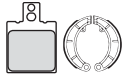

Pastiglie/Ganasce Anteriori
Front Brake Pads/Shoes

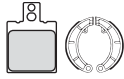

Pastiglie/Ganasce Posteriori
Rear Brake Pads/Shoes



Dischi Freno Anteriore
Front Brake Disk



Dischi Freno Posteriori
Rear Brake Disk



Lamelle
Reeds



Valvole Lamellari
Reed Valve



Valvola Power Reed
Power Reed Valve



Collettori Aspirazione
Intake Manifolds



Fermacopertoni Anteriore
Front Tire Locks



Fermacopertoni Posteriori
Rear Tire Locks

COD	PAG	COD	PAG	COD	PAG	COD	PAG	COD	PAG	COD	PAG	COD	PAG	COD	PAG	COD	PAG	COD	PAG
P.150	232																		
P.067	214	P.012	208																
P.192	247	P.172	238																
P.168	236	P.172	238																
P.129	227	P.079	218																
P.076	218	P.076	218																
P.057	211	P.057	211																
P.057	211	P.057	211																
P.087	221	P.057	211																
P.057	211	P.057	211																
		P.057	211																
		P.057	211																
P.057	211	P.057	211																
P.057	211	P.057	211																
P.086	220	P.116	226																
P.150	232																		
P.177	241																		
		P.057	211																
		P.057	211																
		P.057	211																
P.242	269																		
P.087	221	P.057	211																
		P.243	269																
		P.243	269																
P.177	241	P.197	249																
P.177	241	P.197	249																
P.057	211	P.057	211																
P.057	211	P.057	211																
P.150	232	P.057	211																
		P.243	269																
P.177	241	P.134	228																
P.242	269																		
		P.057	211																
		P.057	211																
		P.057	211																
P.177	241																		
		P.057	211																
P.057	211																		
P.177	241	P.057	211																
P.177	241																		
P.177	241																		
P.177	241																		
P.177	241	P.134	228																
P.225	261	P.134	228																
P.177	241	P.057	211																
P.057	211	P.057	211																
P.057	211																		
P.150	232																		
P.165	235	P.057	211																
P.150	232	P.057	211																
P.165	235	P.057	211																
P.057	211	P.057	211																
P.087	221																		

MARCA - MODELLO MAKE - MODEL



Serie
Dischi Rivestiti
Friction Plate Kit



RACING
Serie
Dischi Rivestiti
Friction Plate Kit



Serie Completa
Dischi Frizione
Clutch Plates
Complete Set



RACING
Serie Completa
Dischi Frizione
Clutch Plates
Complete Set



Frizione
Antisaltemento
Slipper Clutches



Carter Frizione
Clutch Covers

YAMAHA	CC	MY	COD	PAG	COD	PAG	COD	PAG	COD	PAG	COD	PAG	COD	PAG
FJ 1200 W WC	1200	89												
FJ A	1200	91	95	YA-75	165									
V MAX	1200	91	92											
V MAX	1200	93	03											
XJR	1200	95	98	YA-75	165									
XTZ 1200 SUPER TENERE	1200	10												
XTZ 1200 ZE	1200	14												
1300 STRYKER	1300	11												
FJR 1300	1300	01												
FJR 1300 A	1300	03												
FJR 1300 A ABS	1300	06												
FJR 1300 A ABS	1300	11												
FJR 1300 ABS	1300	06												
FJR 1300 AS	1300	06												
FJR N/P	1300	01	02											
FJR R/AR/S/AS/AT	1300	03	05											
XJR	1300	98		YA-75	165									
XJR P/R/S/T	1300	02	05	YA-75	165									
XJR/XJR SP	1300	99	01	YA-75	165									
XV 1300 AH/ATH ROYAL STAR	1300	96												
XVS 1300 A MIDNIGHT STAR	1300	07												
XVZ ROYAL STAR	1300	96	01											
XVZ 1300 TD	1300	88												
XVZ 1300 TF ROYAL STAR VENTURE	1300	99												
XV 1600 ROAD STAR SILVERADO	1600	99												
XV A WILD STAR	1600	99	04											
XV 1670 ROYALS STAR WARRIOR	1670	02												
MT-01	1700	05	06											
MT-01	1700	07												
V MAX 1700	1700	09												
XV 1700 PC ROAD STAR WARRIOR	1700	03												
XV 1700 ROAD STAR WARRIOR	1700	02												
XV 1700 WARRIOR	1700	03												
XV MIDNIGHT STAR	1700	06												
XV PC ROAD STAR WARRIOR	1700	03												
XV PCR ROAD STAR WARRIOR	1700	03	05											
XV ROAD STAR WARRIOR	1700	02												
XV 1900 A MIDNIGHT STAR	1900	07												
XV 1900 MIDNIGHT STAR	1900	06												
YAMAHA ATV	CC	MY												
YXR 660 RHINO 4x4pinza sx	660	04												
YFM 700 RAPTORpinza sx	700	06												
ZUNDAPP	CC	MY												
KS 125	125	82												
KS 175	175	82												

FRENI - BRAKES

VALVOLE - REEDS

COLLETTORI INTAKE MANIFOLDS

FERMACOPERTONI TIRE LOCKS

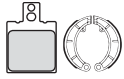

Pastiglie/Ganasce Anteriori
Front Brake Pads/Shoes

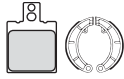

Pastiglie/Ganasce Posteriori
Rear Brake Pads/Shoes



Dischi Freno Anteriore
Front Brake Disk



Dischi Freno Posteriori
Rear Brake Disk



Lamelle
Reeds



Valvole Lamellari
Reed Valve



Valvola Power Reed
Power Reed Valve



Collettori Aspirazione
Intake Manifolds



Fermacopertoni Anteriore
Front Tire Locks



Fermacopertoni Posteriori
Rear Tire Locks

COD	PAG	COD	PAG	COD	PAG	COD	PAG	COD	PAG	COD	PAG	COD	PAG	COD	PAG	COD	PAG	COD	PAG
P.242	269																		
P.057	211	P.057	211																
		P.057	211																
P.087	221	P.057	211																
		P.243	269																
		P.243	269																
		P.243	269																
		P.243	269																
		P.243	269																
		P.243	269																
		P.243	269																
P.177	241	P.197	249																
P.177	241	P.197	249																
P.168	236	P.057	211																
P.177	241																		
P.177	241	P.057	211																
		P.242	269																
		P.243	269																
P.087	221	P.087	221																
P.242	269	P.242	269																
		P.242	269																
		P.242	269																
P.150	232	P.087	221																
		P.243	269																
P.177	241																		
P.225	261																		
		P.243	269																
		P.243	269																
		P.242	269																
		P.243	269																
P.177	241																		
P.177	241																		
P.177	241	P.197	249																
P.177	241	P.087	221																
		P.243	269																
		P.243	269																
		P.247	272																
		P.247	272																
P.245	270																		
P.245	270																		

Dischi Frizione

I kit frizione ADIGE® derivano da una lunga esperienza acquisita in più di 50 anni di collaborazione con le più importanti Case motociclistiche mondiali e con i Team ufficiali che partecipano ai campionati del mondo delle varie discipline e sono il risultato delle ricerche del reparto R&D ADIGE®.

Ogni materiale d'attrito ADIGE® è studiato e verificato per l'applicazione specifica ed è disponibile in kit realizzati per il modello specifico per il quale viene proposto. Tutti i materiali d'attrito sono formulati, sviluppati e prodotti direttamente presso i nostri stabilimenti e vengono controllati in tutte le fasi del processo in accordo a severi standard qualitativi.

La gamma di dischi frizione ADIGE® include i seguenti materiali di attrito:

Friction Plates

The ADIGE® friction plate kits are the result of the experience acquired through more than 50 years of cooperation with the most important motorcycle manufacturers and factory teams competing in the World Championships of various classes combined with the research of the ADIGE® R&D Department.

Each ADIGE® friction material is designed and verified for the application and available in sets realized specifically for the proposed model. All the friction materials are formulated, developed and produced in our plants and are strictly controlled in all phases of the production process.

The range of ADIGE® friction plates include the following friction materials:



BASE CARTA BAGNO D'OLIO:

Prodotti con un materiale a base carta per utilizzo a bagno d'olio, ottenuto utilizzando componenti high-tech selezionatissimi e dall'elevata stabilità termica, chimica e dimensionale, i dischi frizione ADIGE® sono perfetti per l'uso nelle competizioni ed hanno le seguenti caratteristiche:

- Massime prestazioni
- Massima stabilità dimensionale
- Massima stabilità del coefficiente d'attrito
- Ridottissima usura
- Massima modulabilità

BASE GOMMA BAGNO D'OLIO:

Prodotti con un materiale a base gomma per utilizzo a bagno d'olio, ottenuto utilizzando componenti di elevata stabilità termica e chimica, i dischi frizione ADIGE® sono perfetti per l'uso anche nelle condizioni più esasperate ed hanno le seguenti caratteristiche:

- Ottime prestazioni
- Ottima stabilità dimensionale
- Massima stabilità del coefficiente d'attrito
- Limitatissima usura
- Ottima modulabilità

SINTERIZZATO SECCO:

Prodotti con un materiale sinterizzato per utilizzo a secco, ottenuto da polveri metalliche nobili, di composizione e granulometria supercontrollata, i dischi frizione ADIGE® sono perfetti per l'uso nelle competizioni ed hanno le seguenti caratteristiche:

- Elevato coefficiente d'attrito
- Massime prestazioni
- Massima stabilità dimensionale
- Massima stabilità del coefficiente d'attrito
- Ridottissima usura
- Massima modulabilità

BASE GOMMA SECCO:

Prodotti con un materiale a base gomma per utilizzo a secco, ottenuti utilizzando componenti di elevatissima stabilità termica, chimica e dimensionale, i dischi frizione ADIGE® sono perfetti per l'uso anche nelle condizioni più esasperate ed hanno le seguenti caratteristiche:

- Elevato coefficiente d'attrito
- Ottime prestazioni
- Ottima stabilità dimensionale
- Massima stabilità del coefficiente d'attrito
- Limitatissima usura
- Ottima modulabilità

PAPER BASED WET CLUTCH:

Produced with a paper based friction material to be used in a wet clutch, ADIGE® paper based friction plates are produced with selected high-tech components with a very high thermal, chemical and dimensional stability. ADIGE® paper based friction plates are perfect for racing use and have the following features:

- *Maximum performance*
- *Maximum dimensional stability*
- *Maximum friction coefficient stability*
- *Very low wear*



RUBBER BASED WET CLUTCH:

Produced with a rubber based friction material to be used in a wet clutch, ADIGE® rubber based friction plates are produced with components with a really high thermal, chemical and dimensional stability ADIGE® rubber based friction plates are perfect for use even in the most demanding situations and have the following features:

- *Very good performance*
- *Very good dimensional stability*
- *Very good friction coefficient stability*
- *Very low wear*



SINTERED DRY CLUTCH:

Produced with a sintered material to be used in a dry clutch, ADIGE® sintered friction plates are produced with select high-tech metal powders of noble metals and with controlled granulometry. ADIGE® sintered friction plates are perfect for racing use and have the following features:

- *High friction coefficient*
- *Maximum performance*
- *Maximum dimensional stability*
- *Maximum friction coefficient stability*
- *Very low wear*



RUBBER BASED DRY CLUTCH:

Produced with a rubber based friction material to be used in a dry clutch, ADIGE® rubber based friction plates are produced with components with a very high thermal, chemical and dimensional stability. ADIGE® rubber based friction plates are perfect for use even in the most demanding situations and have the following features:

- *High friction coefficient*
- *Very good performance*
- *Very good dimensional stability*
- *Maximum friction coefficient stability*
- *Very low wear*



SERIE DISCHI RIVESTITI E RACING FRICTION PLATE KIT AND RACING

▶ **AP-12**
BASE GOMMA BAGNO D'OLIO
RUBBER BASED WET CLUTCH

APRILIA	CC	MY
DORSODURO	750	08
SHIVER	750	07



▶ **AP-13**
BASE GOMMA BAGNO D'OLIO
RUBBER BASED WET CLUTCH

APRILIA	CC	MY
DORSODURO	1200	10

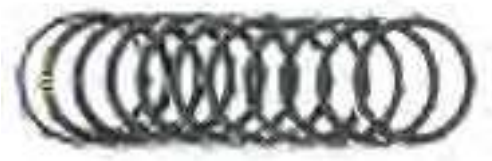

▶ **BR-20**
BASE GOMMA BAGNO D'OLIO
RUBBER BASED WET CLUTCH

APRILIA	CC	MY
TUAREG RALLY	250	85



▶ **BR-36**
BASE GOMMA BAGNO D'OLIO
RUBBER BASED WET CLUTCH

APRILIA	CC	MY
TUAREG WIND	600	89
TUAREG WIND PARIGI DAKAR	600	89



SERIE DISCHI RIVESTITI E RACING FRICTION PLATE KIT AND RACING

BR-46

BASE GOMMA BAGNO D'OLIO
RUBBER BASED WET CLUTCH



APRILIA	CC	MY
AF 1	125	85
AF 1 FUTURA	125	90 92
AF 1 SINTESI	125	88
AF 1 SINTESI REPLICA	125	89 90
CLASSIC	125	95 99
ETX	125	86
EUROPA	125	90 91
MX	125	04 06
PEGASO	125	89 90
PEGASO	125	91 94
PEGASO KAT	125	93
RC	125	89
RED ROSE	125	87 94
RED ROSE AE	125	91
RS	125	96 10
RS	125	92 94
RS	125	95

RX	125	85 88
RX	125	94
RX	125	95 98
RX	125	89 93
RX - SX	125	08 10
SPORT PRO	125	93
TUAREG RALLY	125	85 88
TUAREG RALLY	125	89 90
TUAREG WIND	125	89
TUONO	125	03 04
TX M	125	85
TX	240	86
CLIMBER	250	90
CLIMBER R	250	92
CLIMBER R	280	93
TX M	300	86
TX M	311	85
TXR M	312	88

BR-57

BASE GOMMA BAGNO D'OLIO
RUBBER BASED WET CLUTCH



APRILIA	CC	MY
PEGASO 4 VALVOLE	600	91
PEGASO AE	600	91
TUAREG WIND AE	600	91
PEGASO	650	91 93

BR-64

BASE GOMMA BAGNO D'OLIO
RUBBER BASED WET CLUTCH



APRILIA	CC	MY
BLUE MARLIN	1000	02
ETV-CAPONORD/RAID	1000	01 02
PEGASO	1000	01
RST FUTURA	1000	01 04
RSV FACTORY	1000	04
RSV MILLE	1000	98 00
RSV MILLE	1000	01 05
RSV MILLE NERA	1000	04
RSV MILLE R	1000	00
RSV MILLE R	1000	01 07
RSV MILLE SL FALCO	1000	00
RSV MILLE SP	1000	00
RSV TUONO	1000	02
RSV TUONO RACING	1000	04

BR-66

BASE GOMMA BAGNO D'OLIO
RUBBER BASED WET CLUTCH

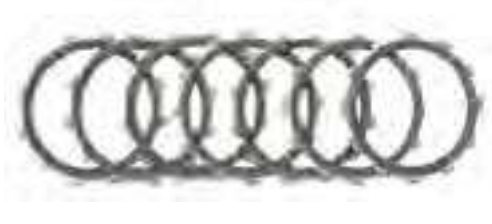

APRILIA	CC	MY
MOTO 6.5	650	95
PEGASO	650	94 95
PEGASO	650	96
PEGASO	650	97 00
PEGASO	650	07
PEGASO	650	06
PEGASO I.E.	650	01 04
PEGASO STRADA	650	05 06

SERIE DISCHI RIVESTITI E RACING FRICTION PLATE KIT AND RACING

BR-76

BASE GOMMA BAGNO D'OLIO
RUBBER BASED WET CLUTCH



BMW	CC	MY
F 650	650	93 00
F 650 CS / SCARVER	650	00 06
F 650 GS	650	93 07
F 650 GS DAKAR	650	93 07
F 650 ST	650	93 00
G 650 XCHALLENGE	650	07
G 650 XCOUNTRY	650	07
G 650 XMOTO	650	07
R 65 R	650	93

BT-55

BASE GOMMA BAGNO D'OLIO
RUBBER BASED WET CLUTCH



BETA	CC	MY
TR 34	125	88
TR 34 R CAMPIONATO	125	89
TR 35	125	91
ZERO	125	92
ALP	240	96
ST	240	92
SYNT	260	92 93
SYNT	260	94
TR 34 R CAMPIONATO	260	88
TR 34 R SUPER TRIAL	260	89
TR 35 REVERSE	260	90
ZERO	260	89 92
ZERO	260	98
ZERO GARA	260	93

BT-68

BASE GOMMA BAGNO D'OLIO
RUBBER BASED WET CLUTCH



BETA	CC	MY
REV 3	250	00 04
REV 3	250	05 07
TECHNO	250	94
REV 3	270	00 04
REV 3	270	05 07

DB-12

BASE GOMMA BAGNO D'OLIO
RUBBER BASED WET CLUTCH

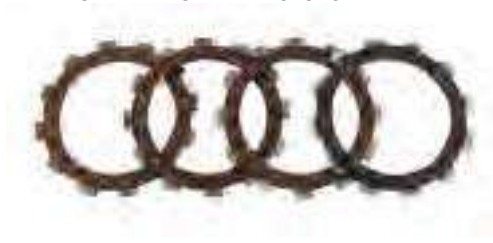

APRILIA	CC	MY
RS	50	07
RX RACING	50	07
DERBI	CC	MY
GPR R	50	97
GPR SPORT	50	96
SENDA	50	93 97
SENDA R DRD	50	02
SENDA SM DRD	50	02
SENDA SM DRD	50	03
SENDA SUPERMOTARD	50	98 01
SENDA X - TREM R	50	03
GPR	80	92

SERIE DISCHI RIVESTITI E RACING FRICTION PLATE KIT AND RACING

DU-45

BASE GOMMA SECCO
RUBBER BASED DRY CLUTCH



CAGIVA	CC	MY
ALAZZURRA GT	650	87
ELEFANT	650	87
PARIGI DAKAR	650	86
TOURING	650	86
DUCATI	CC	MY
F 3	350	87
INDIANA	350	87
DESMO	650	87
INDIANA	650	87
INDIANA	750	88
LAGUNA SECA	750	87
SANTA MONICA	750	88

DU-56

BASE GOMMA SECCO
RUBBER BASED DRY CLUTCH



CAGIVA	CC	MY
CANYON	900	97
ELEFANT	900	91
ELEFANT CATALITICA	900	93
ELEFANT I.E.	900	91
DUCATI	CC	MY
748 BIPOSTO	748	95 97
748 DESMO 4	748	94
748 R	748	00
748 R	748	01
748 SP	748	95 97
748 SPS	748	98
749 BIPOSTO	748	98

900 SUPERLIGHT	900	92	96
M 900 MONSTER	904	93	99
M 900 MONSTER	904	00	
M 900 MONSTER	904	01	
SS 900	904	91	97
SS 900	904	98	00
907 I.E.	907	91	
916 SP	916	94	97
916 STRADA	916	94	98
ST 4	916	99	00
ST 2	944	97	00
996 BIPOSTO	996	98	00

DU-74

SINTERIZZATO SECCO
SINTERED DRY CLUTCH



DUCATI	CC	MY
851 SP	851	91
851 STRADA	851	89
888 CORSA	888	91
888 DESMO 4	888	93 94
888 SPS	888	90 93
888 STRADA	888	94
888 SUPERBIKE	888	94 95
916 SPS	916	98
996 R	996	99 01
996 SPS	996	98 00
998 R	998	02
999 R	999	03

DU-79

BASE GOMMA SECCO
RUBBER BASED DRY CLUTCH



DUCATI	CC	MY
SPORT	350	91
SS JUNIOR	400	91
PASO	750	86
PASO	750	89
PASO	906	89

SERIE DISCHI RIVESTITI E RACING FRICTION PLATE KIT AND RACING

▶ DU-83 BASE GOMMA SECCO RUBBER BASED DRY CLUTCH



CAGIVA	CC	MY
ELEFANT LUCKY EXPLORER	350	87
DAKAR	750	87
ELEFANT	750	87
ELEFANT	750	88 89
ELEFANT BIFARO	750	90 93
LUCKY EXPLORER	750	88
ELEFANT	900	90
ELEFANT	906	89

▶ DU-89 BASE GOMMA BAGNO D'OLIO RUBBER BASED WET CLUTCH



CAGIVA	CC	MY
ELEFANT	750	94

DUCATI	CC	MY
SS 400	400	93
M 600 MONSTER	600	94 97
SS 600	600	94
M 750 MONSTER	750	96 97
SS 750	750	91 97

▶ DU-105 BASE GOMMA BAGNO D'OLIO RUBBER BASED WET CLUTCH



DUCATI	CC	MY
M 600 MONSTER	600	98 99
M 600 MONSTER	600	99 01
MONSTER DARK I.E.	618	03
MONSTER I.E.	618	02
MONSTER S I.E.	618	03
SS	618	03
M 750 MONSTER	750	98 99
M 750 MONSTER	750	99 01
SS 750	750	98 99
SS 750	750	00
SPORT	802	03
M 800 MONSTER DARK	803	03
M 800 MONSTER S I.E.	803	03
SS	803	03

▶ DU-111 BASE GOMMA BAGNO D'OLIO RUBBER BASED WET CLUTCH

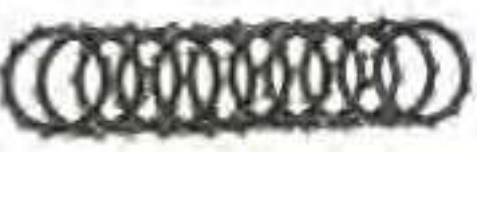

DUCATI	CC	MY
M620	618	05
M620 DARK	618	05
MONSTER S I.E.	618	03
SS	618	04
695 MONSTER	695	06
696 MONSTER	696	08
796 HYPERMOTARD	796	10
796 MONSTER	796	13
M 800 MONSTER DARK	803	03
M 800 MONSTER S I.E.	803	03
S2 R	803	05
S2 R DARK	803	05

SERIE DISCHI RIVESTITI E RACING FRICTION PLATE KIT AND RACING

DU-113

BASE GOMMA SECCO
RUBBER BASED DRY CLUTCH



BIMOTA	CC	MY
DB 5 MILLE	992	05
TESI II D	992	04 06
SB8 K SANTAMONICA	996	06
DUCATI	CC	MY
749	748	03
749 DARK	748	04
749 S	748	03
SS 900	904	01
MONSTER S4	916	01
ST 4	916	01 04
ST 2	944	01
PAUL SMART LIMITED	992	06
S2R	992	06
SPORT CLASSIC	992	06
ST 3	992	05 06
996 BIPOSTO	996	01

996 S	996	99	01
996 SPS	996	01	
S4 R MONSTER	996	05	07
ST 4S	996	01	04
ST 4S-ABS	996	03	04
998	998	02	
998 MATRIX	998	04	
998 S	998	02	
999	999	03	
999 S	999	03	
1000 HF I.E.	1000	03	
1000 MULTISTRADA DS	1000	03	
1000 SS I.E.	1000	03	
MONSTER DARK I.E.	1000	03	
MONSTER S I.E.	1000	03	
S2 R MONSTER	1000	06	

DU-114

BASE GOMMA SECCO
RUBBER BASED DRY CLUTCH



DUCATI	CC	MY
749 R	749	03

DU-116

BASE GOMMA SECCO
RUBBER BASED DRY CLUTCH



BIMOTA	CC	MY
DB 5	1078	06 07
DB 5 R	1078	06 07
DB 6 DELIRIO	1078	07
TESI III D	1078	07
DUCATI	CC	MY
HYPERMOTARD	1078	07 09
HYPERMOTARD	1078	10
HYPERMOTARD S	1078	07 09
HYPERMOTARD S	1078	10
1098	1099	07 08
1098	1099	09

1098 R	1099	07
1098 S	1099	07 08
1098 S	1099	09
1098 TRICOLORE	1099	07
STREETFIGHTER	1099	10
1198 S	1198	09
1198	1199	09

DU-124

BASE GOMMA BAGNO D'OLIO
RUBBER BASED WET CLUTCH

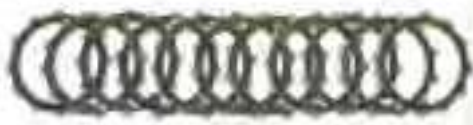

DUCATI	CC	MY
HYPERMOTARD	821	13
HYPERMOTARD SP	821	13
HYPERSTRADA	821	13
MONSTER	821	14
MONSTER DARK	821	14

▶ **DU-126**
BASE GOMMA BAGNO D'OLIO
RUBBER BASED WET CLUTCH

DUCATI	CC	MY
SCRAMBLER	800	14



▶ **DU-128**
BASE GOMMA BAGNO D'OLIO
RUBBER BASED WET CLUTCH

DUCATI	CC	MY
SCRAMBLER	400	14



▶ **FB-22**
BASE GOMMA BAGNO D'OLIO
RUBBER BASED WET CLUTCH

MINARELLI	CC	MY
P 4 SPECIAL	50	88



▶ **FB-70**
BASE GOMMA BAGNO D'OLIO
RUBBER BASED WET CLUTCH

MINARELLI	CC	MY
P 4 SPORT	50	88



SERIE DISCHI RIVESTITI E RACING FRICTION PLATE KIT AND RACING

▶ **FB-104** BASE GOMMA BAGNO D'OLIO RUBBER BASED WET CLUTCH

LAVERDA	CC	MY
OR ATLAS	50	86



▶ **FB-116** BASE GOMMA BAGNO D'OLIO RUBBER BASED WET CLUTCH



APRILIA	CC	MY
AF 1	50	85
AF 1 AE	50	86
ET	50	85
ET AE	50	87
RED ROSE	50	88 91
RX	50	90 91
TUAREG	50	85
TUAREG	50	86
TUAREG	50	87 90
LAVERDA	CC	MY
GAUCHO	50	90
OR ATLAS	50	89
OR ATLAS ADVENTURE	50	88
MALAGUTI	CC	MY
DUNE ES-KS	50	89

MEX	50	86
MRX	50	89
RST	50	90
MINARELLI	CC	MY
C4	50	89
DL 3	50	89
DL 4	50	89
P 4	50	88
P 6	50	88
RV 3 (CILINDRO APRILIA)	50	89
RV 3 (CILINDRO ORIGINALE)	50	89
RV 4 (CILINDRO APRILIA)	50	89
RV 4 (CILINDRO ORIGINALE)	50	89
RV 6 (CILINDRO APRILIA)	50	89

▶ **FB-127** BASE GOMMA BAGNO D'OLIO RUBBER BASED WET CLUTCH

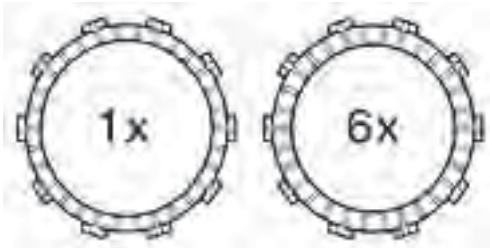

RIEJU	CC	MY
MRX	125	03
SMX	125	03
YAMAHA	CC	MY
DT R	125	88 03
DT RE	125	04
DT RE	125	05 07
DT X	125	05
TDR	125	89 92
TDR R	125	93 03
TZR	125	93
TZR RR	125	94
TZR R	150	00
WR D/E/F	200	92 94
YFS B/F-H/J-N/P/R-T	200	91 02
YFS R/S/T	200	03 05

SERIE DISCHI RIVESTITI E RACING FRICTION PLATE KIT AND RACING

FB-132

BASE GOMMA BAGNO D'OLIO
RUBBER BASED WET CLUTCH



APRILIA	CC	MY
AF 1 FUTURA	50	91
CLASSIC	50	96
EUROPA	50	91
MX SUPERMOTARD	50	02
PEGASO	50	94
RED ROSE	50	92
RS	50	96 99
RS	50	00 06
RS EXTREMA	50	94
RS REPLICA	50	99
RX	50	92 97
RX	50	98
RX C-CD	50	93
RX RACING	50	04 06
SX	50	06
TUAREG	50	91
TUAREG RALLY	50	90
TUAREG WIND	50	90
TUONO	50	04
CLASSIC	80	93
BETA	CC	MY
RK 6 ENDURO	50	97 02
RK 6 T SUPERMOTARD	50	00
RR	50	00 05
RR - T	50	03
RR ENDURO ALU	50	03
RR ENDURO ALU	50	04 07
RR MOTARD ALU	50	03

RR MOTARD ALU	50	04 07
HM	CC	MY
CRE BAJA	50	01 02
CRE BAJA	50	03 06
CRE ENDURO	50	99
DERAPAGE	50	01 02
DERAPAGE	50	03 06
SIX	50	03 06
MALAGUTI	CC	MY
DRAKON	50	06
XSM SUPERMOTARD	50	03
XTM	50	03
MBK	CC	MY
X-LIMIT	50	00
MINARELLI	CC	MY
AM 345	50	91
RIEJU	CC	MY
MRX PRO	50	05
MRX RACING	50	02
NKD	50	05
RACING SPECIAL EDITION	50	01
RS1 CASTROL	50	01
RS2 MATRIX	50	03
SMX	50	02
SPIKE	50	02
SPIKE RACING	50	02
YAMAHA	CC	MY
DT R	50	97 01
DT R	50	02 04

FB-132/M **RACING**

BASE GOMMA BAGNO D'OLIO
RUBBER BASED WET CLUTCH



APRILIA	CC	MY
AF 1 FUTURA	50	91
CLASSIC	50	96
EUROPA	50	91
MX SUPERMOTARD	50	02
PEGASO	50	94
RED ROSE	50	92
RS	50	96 99
RS	50	00 06
RS EXTREMA	50	94
RS REPLICA	50	99
RX	50	92 97
RX	50	98
RX C-CD	50	93
RX RACING	50	04 06
SX	50	06
TUAREG	50	91
TUAREG RALLY	50	90
TUAREG WIND	50	90
TUONO	50	04
CLASSIC	80	93
BETA	CC	MY
RK 6 ENDURO	50	97 02
RK 6 T SUPERMOTARD	50	00
RR	50	00 05
RR - T	50	03
RR ENDURO ALU	50	03
RR ENDURO ALU	50	04 07
RR MOTARD ALU	50	03

RR MOTARD ALU	50	04 07
HM	CC	MY
CRE BAJA	50	01 02
CRE BAJA	50	03 06
CRE ENDURO	50	99
DERAPAGE	50	01 02
DERAPAGE	50	03 06
SIX	50	03 06
MALAGUTI	CC	MY
DRAKON	50	06
XSM SUPERMOTARD	50	03
XTM	50	03
MBK	CC	MY
X-LIMIT	50	00
MINARELLI	CC	MY
AM 345	50	91
RIEJU	CC	MY
MRX PRO	50	05
MRX RACING	50	02
NKD	50	05
RACING SPECIAL EDITION	50	01
RS1 CASTROL	50	01
RS2 MATRIX	50	03
SMX	50	02
SPIKE	50	02
SPIKE RACING	50	02
YAMAHA	CC	MY
DT R	50	97 01
DT R	50	02 04

SERIE DISCHI RIVESTITI E RACING FRICTION PLATE KIT AND RACING

GI-81

BASE GOMMA BAGNO D'OLIO
RUBBER BASED WET CLUTCH



GILERA	CC	MY
AR ARIZONA RALLY	250	86
HX LC	250	83
N R G	250	87
NE	250	83
NX	250	83
RAIDER	250	86
RALLY	250	86
DAKOTA 4 T	350	86
ER	350	87
XRT	350	89

GI-102

BASE GOMMA BAGNO D'OLIO
RUBBER BASED WET CLUTCH



GILERA	CC	MY
A-E ARIZONA RZE	125	87
CCM APTS	125	87
ER	125	87
FAST BIKE	125	87
KZ	125	86
KZ ENDURANCE	125	88
MX 1	125	88
MXR	125	89
R 1	125	88
RC RALLY	125	88
RRT NEBRASKA	125	87
RTX	125	86
RV	125	84

RV ES	125	87
RVE A-E	125	87
RX ARIZONA	125	83
TX 1	125	88
X 1	125	89
XR 1	125	88
XR 2	125	89
ARIZONA	200	83
ER	200	87
FAST BIKE	200	87
RTX	200	86
RV A-E	200	87
RV ES	200	87
RX	200	83

GI-121

BASE GOMMA BAGNO D'OLIO
RUBBER BASED WET CLUTCH



GILERA	CC	MY
NORDWEST	350	94
NORDWEST	600	91
RC	600	88
RC	600	89
RC 4 VALVOLE	600	91
RC R	600	92
RC R-COBRA	600	94
XRT	600	88
XRT	600	89

GI-128

BASE GOMMA BAGNO D'OLIO
RUBBER BASED WET CLUTCH



GILERA	CC	MY
APACHE	125	92
CRONO AE	125	91
CX-AE	125	91
FREESTYLE	125	92
GFR	125	93
RC	125	90
RC TOP RALLY	125	90
SATURNO PIUMA	125	90
SP 01	125	89
SP 02	125	90

▶ GI-130

BASE GOMMA BAGNO D'OLIO
RUBBER BASED WET CLUTCH



GILERA	CC	MY
503	50	92
BULLIT	50	90
RALLY	50	90

▶ GS-4

BASE GOMMA BAGNO D'OLIO
RUBBER BASED WET CLUTCH



GAS GAS	CC	MY
EC 2T	200	07
EC HOBBY 2T	200	07 08
EC 2T	250	07
EC 2T	300	07
EC SIX DAYS 2T	300	09
EC 4T	450	09
FSR 4T	450	07
EC 4T	515	09
FSR 4T	515	08

▶ HO-16

BASE GOMMA BAGNO D'OLIO
RUBBER BASED WET CLUTCH



HONDA	CC	MY
CB-T	500	78
CB-K1	750	69 70
KAWASAKI	CC	MY
KX D1	250	85
KX D2	250	86
KX B1-B2	500	85
KX B1-B2	500	86

▶ HO-59

BASE GOMMA BAGNO D'OLIO
RUBBER BASED WET CLUTCH



HONDA	CC	MY
NS-FG-FH-RK-RL	125	85 93
CB-RSA-RSD	250	81 84
CL-SC	250	82 84
XL-SB-RC	250	81 82
XR RB-RC-RD	250	81 82

SERIE DISCHI RIVESTITI E RACING FRICTION PLATE KIT AND RACING

▶ H0-61

BASE GOMMA BAGNO D'OLIO
RUBBER BASED WET CLUTCH



HONDA	CC	MY
CRM R	125	90 99
NSR-FM-FN	125	88 89
NSR-FM-FN	125	90
NSR-FM-FN	125	91 03
VT-ED-EF EURO SPORT	500	82 88

▶ H0-62

BASE GOMMA BAGNO D'OLIO
RUBBER BASED WET CLUTCH



HONDA	CC	MY
TRX FWJ FOURTRAX	300	88 99
TRX G-H-J-K-L	350	86 92

▶ H0-63

BASE GOMMA BAGNO D'OLIO
RUBBER BASED WET CLUTCH



HONDA	CC	MY
CB-T-N-NA-NB	250	78 82
CB-SG	350	86 88
CB-F-F1-F2	400	79 81
CB-T-N-NA-NC	400	78 83
CB-DX-K	450	89 92
FT-C	500	82 84
XL-SZ-SB-RC	500	80 82

▶ H0-97

BASE GOMMA BAGNO D'OLIO
RUBBER BASED WET CLUTCH

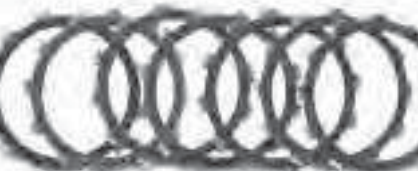

HONDA	CC	MY
CR RD-RK	250	83 86
CR RD-RK	250	87 89
CR RD	480	83
CR RE-RG-RH-RJ-RK	500	84 86
XL-LMF-LMH-RMG	600	85 87
XL-RD-RE-RF-RG	600	83 87
XR RE-RH	600	83 87
XR RE-RH	600	88 90
XR RE-RH	600	91 93
XR RE-RH	600	94 99
FX VIGOR	650	99 03
NX DOMINATOR-T-K-L-M-N	650	87
SLR	650	97 98

SERIE DISCHI RIVESTITI E RACING FRICTION PLATE KIT AND RACING

▶ HO-100 BASE GOMMA BAGNO D'OLIO RUBBER BASED WET CLUTCH



HONDA	CC	MY
CR RH-J-K-L-M-N-P-R-S-T-X	125	94 00
HUSQVARNA	CC	MY
SM S	125	02
WR	125	95 05
WR	125	06
WRE	125	94 00
WRE	125	01
WXE	125	07

▶ HO-106 BASE GOMMA BAGNO D'OLIO RUBBER BASED WET CLUTCH



HONDA	CC	MY
CB-FA-FB-F2C	750	79 82
CB-KZ	750	80
CB-FZ-FA-FB-F2B-F2C-FD	900	81 85
CB-RB2-RC2	1100	80 81

▶ HO-112 BASE GOMMA BAGNO D'OLIO RUBBER BASED WET CLUTCH



HONDA	CC	MY
CBX-FE-FG	750	83 87
VF-CH-CJ	750	87 88
VF-SC	750	82 85

▶ HO-116 BASE GOMMA BAGNO D'OLIO RUBBER BASED WET CLUTCH



HONDA	CC	MY
CR RC	125	82
CR RD-RE-RF-RG	125	83 86
XR RG-H-J-K-L-M-N-P-R-S	250	86 87
XR RT-RX	250	96 02
XR RT-RX	250	03
TRX EX	300	93 05
XR RD-RE	350	83 84
TRX FWS/TN/W/XY	400	95 00
TRX ESW/ESX/ESY	450	98 01

SERIE DISCHI RIVESTITI E RACING FRICTION PLATE KIT AND RACING

H0-117

BASE GOMMA BAGNO D'OLIO
RUBBER BASED WET CLUTCH



HONDA	CC	MY
NSR-RK-RL-RM-RN-RP-RR	125	89
CB SS	400	02
CBR RR	400	90 94
CB R-T	500	94 96
CB V/W/SW/X/SX/Y/SY	500	97 03
CBF 4	500	05
CBF A4/A5	500	04
VT SHADOW-CN-CV	600	91 93
VT SHADOW-CN-CV	600	94 01
XL TRANSALP-VH-VV	600	97 00
SUZUKI	CC	MY
DR R	250	95 00
DR R DEJBEL	250	96 98
DR Z K1-K5	250	01 05

H0-119

BASE GOMMA BAGNO D'OLIO
RUBBER BASED WET CLUTCH

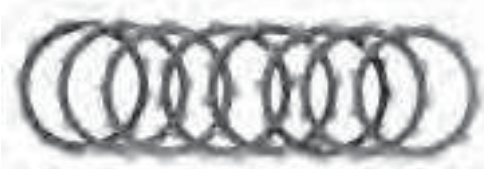

HM	CC	MY
CRE R ENDURO	250	02 07
CRE R SUPERMOTARD	250	02 03
HONDA	CC	MY
CR RL-RM-RN-RP	250	90 93
CR RR-RX	250	94 01
CR RR-RX	250	02
CR RL-RM-RN-RP-RR-RS-RT	500	94 00

H0-134

BASE GOMMA BAGNO D'OLIO
RUBBER BASED WET CLUTCH



HONDA	CC	MY
CB AF7 HORNET ABS	600	07
CB F2Y/Y21/F22 S HORNET	600	00 05
CB F7 HORNET	600	00 06
CB FW/FX HORNET	600	98 99
CB FY/F1-F6 HORNET	600	00 06
CBF N4/NA4/S4/SA4/N5/NA5	600	04
CBR F	600	91 94
CBR F	600	95 98
VF C MAGNA	750	93 99
VFR F	750	85
VFR F	750	86 87
VFR F	750	88 97
VFR-T-V	750	96 97

VFR F	800	98 99
CBR RR	900	92 95
TRIUMPH	CC	MY
DAYTONA	600	03 04
SPEED FOUR	600	03
TT	600	00 03
DAYTONA	650	05

H0-145

BASE GOMMA BAGNO D'OLIO
RUBBER BASED WET CLUTCH



HONDA	CC	MY
CB FR-FT	1000	93 97
CBR F DUAL	1000	93 99
CBR FH-FJ-FK-FL-FV	1000	87 88
VF FE-FF-RE-RFRG	1000	84 86
VT C3 SHADOW	1100	97 00
VT C4 SHADOW SABRE	1100	04
TRIUMPH	CC	MY
DAYTONA	955	99 00
DAYTONA	955	01 04
DAYTONA I.E.	955	05
SPEED TRIPLE	955	99
SPEED TRIPLE T 509	995	99 04

SERIE DISCHI RIVESTITI E RACING FRICTION PLATE KIT AND RACING

▶ HO-148

BASE GOMMA BAGNO D'OLIO
RUBBER BASED WET CLUTCH



HONDA	CC	MY
CBR F4 SPORT	600	02 03
CBR RR	600	03 04
CBR RR	600	05 06
CBR RR	600	07
NTV REVERE-J-K	600	88 89
NTV-L-M-N	600	90 92
NT DEAUVILLE	650	98 01
NT DEAUVILLE	650	02 04
NTV REVERE-P-S-T-V	650	88 90
NTV V	650	02
XL TRANSALP-VH-VV	650	00 05
XRV AFRICA TWIN	650	88 89
VT SHADOW C-C2	750	97 01

VT SHADOW DC	750	02	
VFR A2/A3	800	03	
CB F2/F3/F4/F5 HORNET	900	01	05

▶ HO-149

BASE GOMMA BAGNO D'OLIO
RUBBER BASED WET CLUTCH



HONDA	CC	MY
PC "PACIFIC COAST"	750	89 97
VF-FD-FE	750	83 85
XRV-L V AFRICA TWIN	750	90 93

▶ HO-163

BASE GOMMA BAGNO D'OLIO
RUBBER BASED WET CLUTCH



HONDA	CC	MY
VFR-RJ-RK (RC30) RL	750	88 92

▶ HO-165

BASE GOMMA BAGNO D'OLIO
RUBBER BASED WET CLUTCH



HONDA	CC	MY
NS-RF-RG	400	85 88

SERIE DISCHI RIVESTITI E RACING FRICTION PLATE KIT AND RACING

- ▶ **H0-166**
BASE GOMMA BAGNO D'OLIO
RUBBER BASED WET CLUTCH

HONDA	CC	MY
CBX-RSE	250	84 86



- ▶ **H0-167**
BASE GOMMA BAGNO D'OLIO
RUBBER BASED WET CLUTCH

HONDA	CC	MY
ATC RF-RG-RH	250	85 87
TRX R	250	88 89
TRX RG-RH-RJ-RK	250	86 89
TRX E	400	99 02
XR R	400	96 03
CBR F	600	99 01



- ▶ **H0-171**
BASE GOMMA BAGNO D'OLIO
RUBBER BASED WET CLUTCH

HONDA	CC	MY
GL CV/CW/CX/CY/C1/C2	1500	97 03
GL J-K-L SEN-SEV GOLDWING	1500	88 00



- ▶ **H0-176**
BASE GOMMA BAGNO D'OLIO
RUBBER BASED WET CLUTCH

HONDA	CC	MY
CBR RR	900	96 99



- ▶ **H0-182**
BASE GOMMA BAGNO D'OLIO
RUBBER BASED WET CLUTCH

HM	CC	MY
CR MOTARD	125	04 06
CRE R ENDURO	125	04 07
CRE R SUPERMOTARD	125	02 03
CRE F ENDURO	250	04
CRF MOTARD	250	04 06
HONDA	CC	MY
CR RH-J-K-L-M-N-P-R-S-T-X	125	94 00
CRF R	250	04
KTM	CC	MY
SX-F	250	05 08
XC-F	250	06 08
XC-F-W	250	06 08



SERIE DISCHI RIVESTITI E RACING FRICTION PLATE KIT AND RACING

▶ HO-189 BASE GOMMA BAGNO D'OLIO RUBBER BASED WET CLUTCH



HONDA	CC	MY
VT SHADOW	125	99 05
XL V VARADERO	125	01 05

▶ HO-205 BASE CARTA BAGNO D'OLIO PAPER BASED WET CLUTCH



HONDA	CC	MY
CRF R	450	02
CRF X	450	05

KAWASAKI	CC	MY
KX F	450	06

▶ HU-39 BASE GOMMA BAGNO D'OLIO RUBBER BASED WET CLUTCH



CAGIVA	CC	MY
W 12	350	93
CANYON	500	96 00
RIVER	500	00
CANYON	600	96 99
RIVER	600	00
W 16	600	95

HUSQVARNA	CC	MY
CR	250	92 95
CR	250	96 04
CR	250	05
WR	250	91 92
WR	250	93 05

WR	250	06
WR	260	91
TE	350	95 97
CR	360	92 93
CR	360	94
WR	360	92 93
WR	360	94
TE	410	94 05
TE	410	06
TE E	410	01
TC	610	95
TE	610	95 99
TE E	610	00 03

▶ HU-42 BASE GOMMA BAGNO D'OLIO RUBBER BASED WET CLUTCH



HUSQVARNA	CC	MY
CR	125	92 95
CR	125	96 04
CR	125	05

SERIE DISCHI RIVESTITI E RACING FRICTION PLATE KIT AND RACING

HU-51

BASE GOMMA BAGNO D'OLIO
RUBBER BASED WET CLUTCH



HUSQVARNA	CC	MY
SM R	450	03 06
SM R	450	07
SM RR	450	07
TC	450	05
TE	450	05
SM R	510	01 04
SM R	510	05
TC	510	04
TC	510	05
TE	510	05
TE	510	06
TE LC	510	89
SM R	570	01

SM S	570	01
TC	570	01
TE	570	01 04
LT	610	00
SM R	610	00 05
SM R	610	06
SM S	610	00 05
SM S	610	06
TE E	610	04
SMR	630	06
STR CRC	650	07

KA-3

BASE GOMMA BAGNO D'OLIO
RUBBER BASED WET CLUTCH



KAWASAKI	CC	MY
Z A4-A5	900	76 77
Z A1-A4-H1-H2	1000	77 81

KA-4

BASE GOMMA BAGNO D'OLIO
RUBBER BASED WET CLUTCH



KAWASAKI	CC	MY
Z B1-B3	650	77 81
Z C1-C3	650	77 81
Z D2-D3	650	79 83
Z F1-F4	650	79 83
GPZ A1-A5	750	83 87
GPZ R1	750	82
GT P1-P5	750	82 90
Z E1/H1-H2/L1-L4	750	80 84
Z N1-N2 SPECTRE	750	82 83

KA-19

BASE GOMMA BAGNO D'OLIO
RUBBER BASED WET CLUTCH



KAWASAKI	CC	MY
Z J1-J3	400	80 83
ZR A1-B1	400	83 84
ZR E1-E7	400	94 01
ZR ZEPHYR	400	97 01
ZZ-R	400	90 92
ZZ-R	400	93 99
EN A1-A6	450	85 90
EN A1-A4/B1-B2/C1-C9	500	90 04
ER-5	500	97 00
ER-5	500	01 05
EX A1-A6/D1-D7	500	87 02
GPZ S	500	87 93
GPZ S	500	94 04
KLE A1-A12	500	91 04
Z A1-A3-B1-B2	500	79 81
GPZ	550	81 87

GT G1-G9	550	83 01
Z C1-C2	550	80 81
ZR A1-A2	550	83 88
ZR ZEPHYR	550	91 93
ZR ZEPHYR	550	94 99
GPX R	600	88 96
GPZ R A1-A5	600	85 90
KL A1	600	84
KLR B1-B2-B4-B6-B9	600	85 94
ZL ELIMINATOR	600	95 98
ZZR	600	90 92
ZZR	600	93 05
KL B1 TENGAI-B2-B3	650	89 92
KLR A1-A19	650	87 05
KLX C1-C3	650	93 97
ZXR HI-H2	750	89 90

KA-20

BASE GOMMA BAGNO D'OLIO
RUBBER BASED WET CLUTCH



KAWASAKI	CC	MY
GPZ RX	1000	86 89
GPZ RY	1000	86 89
GTR	1000	86 93
GTR	1000	94 03
Z E1-E2	1000	79 80
Z K1-J1-J3	1000	81 83
Z R2	1000	83
ZL A1-A2	1000	87 88
ZX B1-B2-B3	1000	88 91
GPZ A1-A3	1100	83 88
GPZ B1-B2	1100	81 82
Z A1-A3	1100	81 83

Z R1	1100	84 86
ZR A1-A2-A3-A4-B1	1100	93 95
ZR ZEPHYR A1-A4	1100	92 95
ZR ZEPHYR B1 PINZA SINISTRA	1100	96 98
ZR ZEPHYR B5 PINZA SINISTRA	1100	02
ZRX	1100	97 00

KA-21

BASE GOMMA BAGNO D'OLIO
RUBBER BASED WET CLUTCH



KAWASAKI	CC	MY
KDX A1-A2-B1-B2	125	91 94
KX D1	125	85
KX E1	125	86
KDX C1-C2-C3	200	86 88
KLX D1-D2	250	93 95
KLX F1-F4	250	94 97
KLX G1	250	94 99

KA-23

BASE GOMMA BAGNO D'OLIO
RUBBER BASED WET CLUTCH



KAWASAKI	CC	MY
KX K1	250	94
KX K2-K5/L1-L5	250	95 02
KX M1-M2/R1	250	03
KLR C1-C8	650	94 04
GPX F1-F2-F3	750	87 89
GPZ R G2-G3	750	85 86
VN A2-A3-A4-A5-A10	750	86 95
Z B1-B2	750	77 78
Z D1	750	76
Z Y1 LTD	750	82
ZX 7R	750	96 03
ZX 7RR	750	96 98
ZXR J1-J2/L1-L3/P1-P7	750	91 03
ZXR R	750	91 94

VN A1-A3	800	95 99
VN B1-B10 CLASSIC	800	96 05
VN C1-C2/E1-E3 DRIFTER	800	99 04
GPZ R A1-A6	900	84 89
GPZ R A11	900	98
GPZ R A12-A15	900	99 02
GPZ R A7-A8	900	90 96
ZX 9R B1-B2	900	94 95
ZX 9R B3-B4	900	96 97

KA-24

BASE GOMMA BAGNO D'OLIO
RUBBER BASED WET CLUTCH



KAWASAKI	CC	MY
EL D1-D5	250	90 94
GPX R	250	87 89
ZZ-R	250	90 03
EL	252	97 03

SERIE DISCHI RIVESTITI E RACING FRICTION PLATE KIT AND RACING

▶ KA-27

BASE GOMMA BAGNO D'OLIO
RUBBER BASED WET CLUTCH



KAWASAKI	CC	MY
KX E2/F1	125	87 88
KX G1/H1-H2/J1-J2	125	89 94
KDX E1-E2-E3-E4	200	89 92
KDX E5-E6	200	93 94

▶ KA-34

BASE GOMMA BAGNO D'OLIO
RUBBER BASED WET CLUTCH



KAWASAKI	CC	MY
Z A4-A5	1300	82 83

▶ KA-38

BASE GOMMA BAGNO D'OLIO
RUBBER BASED WET CLUTCH



KAWASAKI	CC	MY
BJ ESTRELLA	250	92 98
BJ ESTRELLA CUSTOM	250	96 99
BJ ESTRELLA RS	250	99 02
BJ F1-F2	250	02 03
ZR A1-A5 BALIUS	250	91 95
ZR B6 BALIUS II	250	02
ZXR	250	89 90
ZXR	250	91 95
ZXR R	250	91
KLF A1-A2 BAYOU	300	86 87
KLF B1-B17 BAYOU	300	88 04
KLF C1-C9 BAYOU LEFT	300	89 99
KLF C1-C9 BAYOU RIGHT	300	89 99

▶ KA-39

BASE GOMMA BAGNO D'OLIO
RUBBER BASED WET CLUTCH



KAWASAKI	CC	MY
KDX B1	250	81
KLF B1-B7 BAYOU LEFT	400	93 99
KLF B1-B7 BAYOU RIGHT	400	93 99

SERIE DISCHI RIVESTITI E RACING FRICTION PLATE KIT AND RACING

▶ **KA-40**
BASE GOMMA BAGNO D'OLIO
RUBBER BASED WET CLUTCH

KAWASAKI	CC	MY
KDX H1-H5	200	95 99
KDX R A1-A12	220	97 05

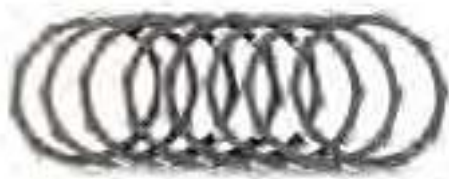

▶ **KA-44**
BASE GOMMA BAGNO D'OLIO
RUBBER BASED WET CLUTCH

KAWASAKI	CC	MY
KR B2	250	89 90
KR C2-C3	250	90 92



▶ **KT-49**
BASE GOMMA BAGNO D'OLIO
RUBBER BASED WET CLUTCH

KTM	CC	MY
GS	250	89 90
MX	250	89



▶ **KT-56**
BASE GOMMA BAGNO D'OLIO
RUBBER BASED WET CLUTCH

KTM	CC	MY
ENDURO	250	92
ENDURO	250	93
EXC	250	03
EXC SIX DAYS	250	10
EXC-EGS- SX	250	93 95
EXC-EGS-SX	250	96 11
GS	250	91 92
GS	250	93
GS	250	94
MX	250	90 02
SX-EGS-EXC	250	93 95
SX-EGS-EXC	250	96 02



ENDURO	300	92
ENDURO	300	93
EXC	300	03
GS	300	91
SX-EGS-EXC	300	93
LC 4 EXC	350	94
MX	350	92

SERIE DISCHI RIVESTITI E RACING FRICTION PLATE KIT AND RACING

MA-66

BASE GOMMA BAGNO D'OLIO
RUBBER BASED WET CLUTCH



CAGIVA	CC	MY
ALETTA ORO S 2	125	86
CRUISER	125	87 88
FRECCIA	125	87
FRECCIA C 9	125	88
WMX	125	85
WMX GP	250	82

MA-78

BASE GOMMA BAGNO D'OLIO
RUBBER BASED WET CLUTCH



CAGIVA	CC	MY
BLUES	125	88
BLUES	125	93
ELEFANT	125	81 84
ELEFANT	125	85 87
ELEFANT 3	125	88
WSTX ALETTA ROSSA	125	83
ALETTA ELECTRA	200	83

MA-146

BASE GOMMA BAGNO D'OLIO
RUBBER BASED WET CLUTCH



CAGIVA	CC	MY
WMX	500	86

MA-162

BASE GOMMA BAGNO D'OLIO
RUBBER BASED WET CLUTCH



CAGIVA	CC	MY
COCIS	50	88
K 3	50	92
LUCKY EXPLORER	50	88
PRIMA	50	92 94
STRADA PRIMA	50	92
SUPER CITY	50	92
W 4	50	92 95

SERIE DISCHI RIVESTITI E RACING FRICTION PLATE KIT AND RACING

MA-174

BASE GOMMA BAGNO D'OLIO
RUBBER BASED WET CLUTCH



CAGIVA	CC	MY
FRECCIA C 10	125	88
FRECCIA C 10 ANNIVERSARY	125	89
FRECCIA C 12 R	125	89
K 7	125	91
MITO	125	90 92
MITO EDDY	125	93
MITO SPORT PRODUCTION	125	91
N 90	125	91
PLANET	125	98 03
RAPTOR	125	03
ROADSTER	125	98 99
SUPER CITY	125	93 00

TAMANACO	125	89
W 8	125	92 98
W 8 PRO ACTION	125	91
WMX	125	88
WMX	125	90
ELEFANT	200	88
ELEFANT	200	89
LAVERDA	CC	MY
NAVARRO	125	90
TOLEDO	125	90

MR-65

BASE GOMMA BAGNO D'OLIO
RUBBER BASED WET CLUTCH



MORINI	CC	MY
COUNTRY	250	88
DART	350	88
EXCALIBUR	350	86
KANGURO	350	88
NEW YORK	350	88
DART	400	89
S	400	95
CAMEL	501	88
COGUARO	501	88
COGUARO	501	89
EXCALIBUR	501	86
EXCALIBUR	501	88

EXCALIBUR	501	89
IXE	501	88
NEW YORK	501	88
NEW YORK	501	89

PG-1

BASE GOMMA BAGNO D'OLIO
RUBBER BASED WET CLUTCH



PEUGEOT	CC	MY
103-104 ALL MODELS	48	

PU-1

BASE GOMMA BAGNO D'OLIO
RUBBER BASED WET CLUTCH



PUCH	CC	MY
COBRA M 82	50	85
CONDOR	50	85
MONZA LUJO	50	85
X 10	50	86
X 20	50	86

SERIE DISCHI RIVESTITI E RACING FRICTION PLATE KIT AND RACING

▶ SU-12

BASE GOMMA BAGNO D'OLIO
RUBBER BASED WET CLUTCH

SUZUKI	CC	MY
GS DB-C-EC-N-T-X-Z-LT KATANA	550	78 79
GSX ESD-EE-ESE-EFE-ESG-ESH	550	84 88



▶ SU-20

BASE GOMMA BAGNO D'OLIO
RUBBER BASED WET CLUTCH

SUZUKI	CC	MY
GSX ESD/EFE/ESG	750	83 86
GSX ET/EX	750	80 81
GSX SE KATANA	750	84
GS GN/GT/GX/GZ/GF/GG	850	79 85



▶ SU-21

BASE GOMMA BAGNO D'OLIO
RUBBER BASED WET CLUTCH

SUZUKI	CC	MY
GS HC-EC-EN-SN-ET	1000	78 80



▶ SU-26

BASE GOMMA BAGNO D'OLIO
RUBBER BASED WET CLUTCH

SUZUKI	CC	MY
PE T/X/Z	250	80 82
RM F	250	85
RM N/T/X/Z/D	250	79 85



SERIE DISCHI RIVESTITI E RACING FRICTION PLATE KIT AND RACING

▶ SU-27 BASE GOMMA BAGNO D'OLIO RUBBER BASED WET CLUTCH

SUZUKI	CC	MY
DR ST-SX	400	80 83
GN TT	400	80



▶ SU-28 BASE GOMMA BAGNO D'OLIO RUBBER BASED WET CLUTCH

SUZUKI	CC	MY
DR SL-ST-SES-SEX	350	90 99
GSX ET/EX/EZ	400	80 82
GS ET-EG-EJ	450	80 88
GS ET/EV/EW/EX/EY/K1-K4	500	89 03
GS FK4/FK5/K5	500	04 05



▶ SU-29 BASE GOMMA BAGNO D'OLIO RUBBER BASED WET CLUTCH

APRILIA	CC	MY
RS	250	95 97
RS	250	98
SUZUKI	CC	MY
RGV J	250	88
RGV K/L	250	89 90
RGV M/N/P/R/S	250	91 95
RGV T	250	96
TV J/K/RK/L	250	88 90
RM X/Z	465	81 82
RM D	500	83
GSF BANDIT	600	95 99

GSF BANDIT	600	00 04
GSX FJ/FK/FL/FM	600	88 91
GSX R F/G/XH	750	85 87



▶ SU-32 BASE GOMMA BAGNO D'OLIO RUBBER BASED WET CLUTCH

SUZUKI	CC	MY
GSX FW/FX/FY/FK1-FK3	600	98 04
GSX W/X/Y/K1 PINZA SINISTRA	750	98 03



SERIE DISCHI RIVESTITI E RACING FRICTION PLATE KIT AND RACING

SU-33

BASE GOMMA BAGNO D'OLIO
RUBBER BASED WET CLUTCH



SUZUKI	CC	MY
GS GT/GX	1000	80 81
GSX SZ KATANA	1000	82
GS GZ KATANA	1100	82
GSX EFE-EFG	1100	84 88
GSX ET-EX-EZ	1100	80 81
GSX SZ	1100	82
VL K2-K3 INTRUDER LC	1500	02 03
VL K5-K6-K7 INTRUDER LC	1500	05 07
VL W/X/Y/K1 INTRUDER LC	1500	98 01

SU-37

BASE GOMMA BAGNO D'OLIO
RUBBER BASED WET CLUTCH



SUZUKI	CC	MY
DR DJEBEL	600	88
DR DJEBEL-DAKAR	600	89
DR SF-RG RAIDER	600	85 87
LS FG/PJ/PV SAVAGE	650	87 99

SU-58

BASE GOMMA BAGNO D'OLIO
RUBBER BASED WET CLUTCH



SUZUKI	CC	MY
PE T/X	400	80 81
RM N/T	400	79 80
SP T	400	80
VS GLS/GLT INTRUDER	600	95 97
SV X/SX/Y/SY/K1/SK1-SK2	650	99 02
VS GL ALL MODELS	750	85 90
VL K1-K4 INTRUDER VOLUSIA	800	01 04
VL K5/K6/K7 INTRUDER	800	05 07
VS GLN/GLP/GLR/GLS/GLV	800	92 97
VS K5 INTRUDER	800	05
VX L/M/N/P/R	800	90 96
VZ K5/K6/K7 M INTRUDER	800	05 07
VZ V/W/X/Y/K1-K4 MARAUDER	800	97 04

SU-63

BASE GOMMA BAGNO D'OLIO
RUBBER BASED WET CLUTCH



HONDA	CC	MY
CBR RR	929	00 01
CBR RR	954	02 03

SU-64

BASE GOMMA BAGNO D'OLIO
RUBBER BASED WET CLUTCH



SUZUKI	CC	MY
GSX R K1-K2-K3	750	01 03
GSX R K4-K5	750	04 05
GSX R K6-K7	750	06 07
GSX R-WT-W	750	96 99
RF RS/RS2/RT/RV/RW	900	95 99
TL SV/SW	1000	97 98
GS SS	1200	01
GSF BANDIT	1200	96 00
GSF BANDIT S	1200	01 05
GSF SAK6/AK6/GTSAK6	1200	06
GSX INAZUMA FSW/FSX	1200	98 99

SU-65

BASE GOMMA BAGNO D'OLIO
RUBBER BASED WET CLUTCH



SUZUKI	CC	MY
LT F FW/FX/FY/FK1/FK2 PINZA SIN.	500	98 02

SU-70

BASE GOMMA BAGNO D'OLIO
RUBBER BASED WET CLUTCH



SUZUKI	CC	MY
XN D TURBO	650	83

SU-71

BASE GOMMA BAGNO D'OLIO
RUBBER BASED WET CLUTCH



SUZUKI	CC	MY
RM B-C	100	77 78
RM A/B/C	125	76 78
RM F	125	85
RM X/Z/D	125	81 83
TS RK/RL/RM/RN/RP/RR	125	91 96
GS TT/TX	250	80 81
GSX ET/EX/EZ	250	80 82

SERIE DISCHI RIVESTITI E RACING FRICTION PLATE KIT AND RACING

SU-73

BASE GOMMA BAGNO D'OLIO
RUBBER BASED WET CLUTCH



SUZUKI	CC	MY
DR SET	650	96
XF V/W/X/Y FREEWIND	650	97 02
DR SJ	750	88
DR SK	750	89 90
DR SL	800	90
DR SM	800	91

SU-78

BASE GOMMA BAGNO D'OLIO
RUBBER BASED WET CLUTCH



SUZUKI	CC	MY
GN F/J/M/N/R/T	250	87 98
TU GY/GBK1	250	00 01
TU S/T/XS/XT/X-ST/XSV	250	92 97
TU XTX/XXTY	250	99 00
TU XV/XW	250	97 00
VL Y/K1-K5 INTRUDER	250	01 05

SU-81

BASE GOMMA BAGNO D'OLIO
RUBBER BASED WET CLUTCH



SUZUKI	CC	MY
VS INTRUDER	1400	87 03

SU-82

BASE GOMMA BAGNO D'OLIO
RUBBER BASED WET CLUTCH



SUZUKI	CC	MY
GSX R K1-K5	600	01 05
GSX R V/W/X/Y	600	97 00

SERIE DISCHI RIVESTITI E RACING FRICTION PLATE KIT AND RACING

▶ **SU-86**
BASE GOMMA BAGNO D'OLIO
RUBBER BASED WET CLUTCH



SUZUKI	CC	MY
RM T/V/W/X/Y/K1-K2	250	96 02

▶ **VE-121**
BASE GOMMA BAGNO D'OLIO
RUBBER BASED WET CLUTCH



PIAGGIO	CC	MY
COSA	200	89
VESPA	CC	MY
VESPA GS	160	
VESPA SS	180	
VESPA PE	200	83
VESPA PX ARCOBALENO	200	83
VESPA PX E	200	78
VESPA RALLY	200	87

▶ **VE-155**
BASE GOMMA BAGNO D'OLIO
RUBBER BASED WET CLUTCH



PIAGGIO	CC	MY
COSA	125	89
COSA	150	89
VESPA	CC	MY
VESPA PX	125	
VESPA PX	150	78
VESPA PX ARCOBALENO	150	83
VESPA SPRINT VELOCE	150	
VESPA SUPER	150	

▶ **VE-160**
BASE GOMMA BAGNO D'OLIO
RUBBER BASED WET CLUTCH



PIAGGIO	CC	MY
APE TL 1 SERIE	50	
APE TL 2 SERIE	50	
VESPA	CC	MY
VESPA PK SPECIAL-XL	50	
VESPA SPECIAL	50	
VESPA PRIMAVERA	90	
VESPA ET3	125	
VESPA PK AUTOMATICA	125	86
VESPA PK SPECIAL-XL	125	
VESPA PK XL 2	125	
VESPA PRIMAVERA	125	80

SERIE DISCHI RIVESTITI E RACING FRICTION PLATE KIT AND RACING

▶ VE-362

BASE GOMMA BAGNO D'OLIO
RUBBER BASED WET CLUTCH



PIAGGIO	CC	MY
COSA II	125	92
COSA II	150	92
COSA II	200	92
VESPA	CC	MY
VESPA PX	150	98
VESPA PX	200	98

▶ YA-9

BASE GOMMA BAGNO D'OLIO
RUBBER BASED WET CLUTCH



YAMAHA	CC	MY
XS	650	75 79
YZF R1	1000	98

▶ YA-25

BASE GOMMA BAGNO D'OLIO
RUBBER BASED WET CLUTCH



YAMAHA	CC	MY
IT H/J	250	81 82
XS	250	78 80
YZ H	250	81
SRX (3VN1/3VN2/3VN5)	400	90 96
XS	400	78 79
XS SE	400	80
YZ D/E/F	400	77 79
IT G	425	80 82
IT H/J	465	81 82
YZ G	465	80
YZ H	465	81
XS	750	77 79
XS SE	750	79 80

▶ YA-26

BASE GOMMA BAGNO D'OLIO
RUBBER BASED WET CLUTCH



YAMAHA	CC	MY
XJR R	400	95 96
XJR R	400	97 00
XS B/C/D	500	77 79
FZ	600	87 88
FZ 6 FAZER	600	04 05
XJ	600	84 91
XJ N	600	95 97
XJ N	600	98 03
XJ S DIVERSION	600	92 97
XJ S DIVERSION	600	98 03
YX S/SC/T/TC/UC/U/W/WC/A/AC	600	86 90
YZF R6	600	99 02
YZF R6	600	03 07
LH MIDNIGHT	650	81

XJ	650	80 84
XJ G/H/J/K MAXIM	650	80 83
XJ LK SECA	650	83
XJ RJ SECA	650	82
XJ TURBO	650	82
FZX S/SC/T/TC FAZER	700	86 87
FZ	750	85 86
XJ	750	82 83
XJ RF/RJ/RK SECA	750	81 83
XTZ SUPER TENERE P. SX	750	89 95
TDM	850	91 95
XJ	900	83 90
XJ F	900	85 92
XJ S DIVERSION	900	95 03

SERIE DISCHI RIVESTITI E RACING FRICTION PLATE KIT AND RACING

▶ YA-30 BASE GOMMA BAGNO D'OLIO RUBBER BASED WET CLUTCH



YAMAHA	CC	MY
IT G	250	80
XS SE-C	250	80 81
XVS DRAG STAR	250	01 04
YZ F	250	79

▶ YA-35 BASE GOMMA BAGNO D'OLIO RUBBER BASED WET CLUTCH



YAMAHA	CC	MY
XJ	550	81 83
FZ	750	89 91
FZ	750	87 88
FZX	750	87

▶ YA-42 BASE GOMMA BAGNO D'OLIO RUBBER BASED WET CLUTCH



YAMAHA	CC	MY
SRX (1JL)	400	87
XT	550	83
SRX	600	86 87
SRX (1JK)	600	85 89
SRX (3SX)	600	90 91
TT	600	84
TT E/R/S	600	93 02
TT RES	600	03 04
TT W	600	89 92
XT	600	87
XT	600	84 86
XT E/ZE	600	90 03
XT Z	600	84

XT Z	600	85 88
XT Z	600	89 90
SZR	660	96 97
XT R	660	04 05
XTZ TENERE	660	91 98
YFM R RAPTOR	660	01 05

▶ YA-43 BASE GOMMA BAGNO D'OLIO RUBBER BASED WET CLUTCH



YAMAHA	CC	MY
DT	250	75 76
RD A-F	250	74 79
RD LC	250	80 82
TY D/E	250	77 78
RD A/B	350	74 75
RD LC	350	80 82
RD N/F/F2/R	350	85 95
RD YPVS	350	83 84
TT A (3GJ)	350	90 95
XT	350	85 95
YFZ U/A/B/D-N/P/R-T	350	90 05
DT	400	75 76
RD C/D/E/F	400	76 79

SERIE DISCHI RIVESTITI E RACING FRICTION PLATE KIT AND RACING

▶ YA-60

BASE GOMMA BAGNO D'OLIO
RUBBER BASED WET CLUTCH

YAMAHA	CC	MY
FZR GENESIS	750	87
FZR GENESIS	1000	87 88



▶ YA-75

BASE GOMMA BAGNO D'OLIO
RUBBER BASED WET CLUTCH

YAMAHA	CC	MY
FJ	1100	84 85
FJ	1200	86 87
FJ	1200	88 95
FJ A	1200	91 95
XJR	1200	95 98
XJR	1300	98
XJR P/R/S/T	1300	02 05
XJR/XJR SP	1300	99 01



▶ YA-78

BASE GOMMA BAGNO D'OLIO
RUBBER BASED WET CLUTCH

YAMAHA	CC	MY
SR	250	93 98
SR SE	250	81 82



▶ YA-79

BASE GOMMA BAGNO D'OLIO
RUBBER BASED WET CLUTCH

YAMAHA	CC	MY
FZR RSP (2TK-EXUP)	400	87
FZR	600	89
FZR R	600	90 93



SERIE DISCHI RIVESTITI E RACING FRICTION PLATE KIT AND RACING

▶ YA-80

BASE GOMMA BAGNO D'OLIO
RUBBER BASED WET CLUTCH



YAMAHA	CC	MY
FZR R 0W01	750	89 90
YZF R/SP	750	93 97
TDM	850	96 01
TRX	850	96 98
TDM AT/AV/AW (ABS)	900	05 07
TDM P/R/S/T/V	900	02 06

▶ YA-98

BASE GOMMA BAGNO D'OLIO
RUBBER BASED WET CLUTCH



YAMAHA	CC	MY
YFM FWH/FWJ/FWK BIG BEAR	350	96 98
YFM FWT/FWU BIG BEAR	350	87 88
YFM FWW/FWA/FWB/FWD/FWE/FWF	350	89 95
YFM S/T RAPTOR	350	04 05
YFM XD-XS	350	92 04
DT MX	400	77 79
YFM FPR/FPS BIG BEAR	400	03 04
YFM FWE/FWF/FWG/FWH/FWJ/FWK	400	93 00

▶ YA-101

BASE GOMMA BAGNO D'OLIO
RUBBER BASED WET CLUTCH



YAMAHA	CC	MY
YZF R1	1000	99 01
YZF R1	1000	02 03

▶ YA-110

BASE GOMMA BAGNO D'OLIO
RUBBER BASED WET CLUTCH



YAMAHA	CC	MY
XV VIRAGO	125	97 00
XVS DRAG STAR	125	00 04
XV S VIRAGO	250	95 00
XV VIRAGO	250	89 94

SERIE COMPLETA DISCHI FRIZIONE E RACING CLUTCH PLATES COMPLETE SET AND RACING

▶ AP-11 BASE GOMMA BAGNO D'OLIO RUBBER BASED WET CLUTCH

APRILIA	CC	MY
DORSODURO	750	08
SHIVER	750	07



RICAMBI - SPARE PARTS

AP-12 DISCHI FRIZIONE

▶ AP-14 BASE GOMMA BAGNO D'OLIO RUBBER BASED WET CLUTCH

APRILIA	CC	MY
DORSODURO	1200	10



RICAMBI - SPARE PARTS

AP-13 DISCHI FRIZIONE

▶ BR-50 BASE GOMMA BAGNO D'OLIO RUBBER BASED WET CLUTCH

APRILIA	CC	MY
AF 1	125	85
AF 1 FUTURA	125	90 92
AF 1 SINTESI	125	88
AF 1 SINTESI REPLICA	125	89 90
CLASSIC	125	95 99
ETX	125	86
EUROPA	125	90 91
PEGASO	125	89 90
PEGASO	125	91 94
PEGASO KAT	125	93
RC	125	89
RED ROSE	125	87 94
RED ROSE AE	125	91
RS	125	92 94
RX	125	85 88
RX	125	94
RX	125	89 93
SPORT PRO	125	93
TUAREG RALLY	125	85 88
TUAREG RALLY	125	89 90

TUAREG WIND	125	89
TX M	125	85
TX	240	86
CLIMBER	250	90
CLIMBER R	250	92
CLIMBER R	280	93
TX M	300	86
TX M	311	85
TXR M	312	88



RICAMBI - SPARE PARTS

BR-46 DISCHI FRIZIONE

SERIE COMPLETA DISCHI FRIZIONE E RACING CLUTCH PLATES COMPLETE SET AND RACING

BR-58

BASE GOMMA BAGNO D'OLIO
RUBBER BASED WET CLUTCH



RICAMBI - SPARE PARTS

BR-57 DISCHI FRIZIONE

APRILIA	CC	MY
PEGASO 4 VALVOLE	600	91
PEGASO AE	600	91
TUAREG WIND AE	600	91
PEGASO	650	91 93

BR-63

BASE GOMMA BAGNO D'OLIO
RUBBER BASED WET CLUTCH



RICAMBI - SPARE PARTS

BR-66 DISCHI FRIZIONE

APRILIA	CC	MY
MOTO 6.5	650	95
PEGASO	650	94 95
PEGASO	650	96
PEGASO	650	97 00
PEGASO	650	07
PEGASO	650	06
PEGASO I.E.	650	01 04
PEGASO STRADA	650	05 06

BR-65

BASE GOMMA BAGNO D'OLIO
RUBBER BASED WET CLUTCH



RICAMBI - SPARE PARTS

BR-64 DISCHI FRIZIONE

APRILIA	CC	MY
BLUE MARLIN	1000	02
ETV-CAPONORD/RAID	1000	01 02
PEGASO	1000	01
RST FUTURA	1000	01 04
RSV FACTORY	1000	04
RSV MILLE	1000	98 00
RSV MILLE	1000	01 05
RSV MILLE NERA	1000	04
RSV MILLE R	1000	00
RSV MILLE R	1000	01 07
RSV MILLE SL FALCO	1000	00
RSV MILLE SP	1000	00
RSV TUONO	1000	02
RSV TUONO RACING	1000	04

SERIE COMPLETA DISCHI FRIZIONE E RACING CLUTCH PLATES COMPLETE SET AND RACING

▶ **BR-74**

BASE GOMMA BAGNO D'OLIO
RUBBER BASED WET CLUTCH



APRILIA	CC	MY
MX	125	04 06
RS	125	96 10
RS	125	95
RX	125	95 98
RX - SX	125	08 10
TUONO	125	03 04

RICAMBI - SPARE PARTS

BR-46

DISCHI FRIZIONE

▶ **BR-77**

BASE GOMMA BAGNO D'OLIO
RUBBER BASED WET CLUTCH



BMW	CC	MY
F 650	650	93 00
F 650 CS / SCARVER	650	00 06
F 650 GS	650	93 07
F 650 GS DAKAR	650	93 07
F 650 ST	650	93 00
G 650 XCHALLENGE	650	07
G 650 XCOUNTRY	650	07
G 650 XMOTO	650	07
R 65 R	650	93

RICAMBI - SPARE PARTS

BR-76

DISCHI FRIZIONE

SERIE COMPLETA DISCHI FRIZIONE E RACING CLUTCH PLATES COMPLETE SET AND RACING

▶ BT-40

BASE GOMMA BAGNO D'OLIO
RUBBER BASED WET CLUTCH

MALAGUTI	CC	MY
DRIBBLING	50	85
DRIBBLING PEDALI	50	85
GRIZZLY	50	87

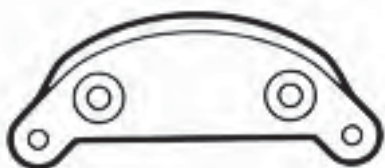

▶ BT-62

BASE GOMMA BAGNO D'OLIO
RUBBER BASED WET CLUTCH

BETA	CC	MY
REV 3	250	00 04
REV 3	250	05 07
TECHNO	250	94
REV 3	270	00 04
REV 3	270	05 07



RICAMBI - SPARE PARTS

BT-68 DISCHI FRIZIONE

▶ DB-12/M

BASE GOMMA BAGNO D'OLIO
RUBBER BASED WET CLUTCH

APRILIA	CC	MY
RS	50	07
RX RACING	50	07
DERBI	CC	MY
GPR R	50	97
GPR SPORT	50	96
SENDA	50	93 97
SENDA R DRD	50	02
SENDA SM DRD	50	02
SENDA SM DRD	50	03
SENDA SUPERMOTARD	50	98 01
SENDA X - TREM R	50	03
GPR	80	92



RICAMBI - SPARE PARTS

DB-12 DISCHI FRIZIONE

SERIE COMPLETA DISCHI FRIZIONE E RACING CLUTCH PLATES COMPLETE SET AND RACING

DU-50

BASE GOMMA SECCO
RUBBER BASED DRY CLUTCH



CAGIVA	CC	MY
ALAZZURRA GT	650	87
ELEFANT	650	87
PARIGI DAKAR	650	86
TOURING	650	86
DUCATI	CC	MY
F 3	350	87
INDIANA	350	87
DESMO	650	87
INDIANA	650	87
INDIANA	750	88
LAGUNA SECA	750	87
SANTA MONICA	750	88

RICAMBI - SPARE PARTS

DU-45

DISCHI FRIZIONE

DU-81

BASE GOMMA SECCO
RUBBER BASED DRY CLUTCH



DUCATI	CC	MY
SPORT	350	91
SS JUNIOR	400	91
PASO	750	86
PASO	750	89
PASO	906	89

RICAMBI - SPARE PARTS

DU-79

DISCHI FRIZIONE

DU-85

BASE GOMMA SECCO
RUBBER BASED DRY CLUTCH



CAGIVA	CC	MY
ELEFANT LUCKY EXPLORER	350	87
DAKAR	750	87
ELEFANT	750	87
ELEFANT	750	88 89
ELEFANT BIFARO	750	90 93
LUCKY EXPLORER	750	88
ELEFANT	900	90
ELEFANT	906	89

RICAMBI - SPARE PARTS

DU-83

DISCHI FRIZIONE

SERIE COMPLETA DISCHI FRIZIONE E RACING CLUTCH PLATES COMPLETE SET AND RACING

DU-90

BASE GOMMA BAGNO D'OLIO
RUBBER BASED WET CLUTCH



RICAMBI - SPARE PARTS

DU-89 DISCHI FRIZIONE

CAGIVA	CC	MY
ELEFANT	750	94
DUCATI	CC	MY
SS 400	400	93
M 600 MONSTER	600	94 97
SS 600	600	94
M 750 MONSTER	750	96 97
SS 750	750	91 97

DU-96

BASE GOMMA SECCO
RUBBER BASED DRY CLUTCH

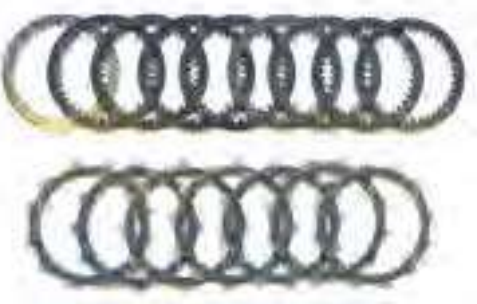

RICAMBI - SPARE PARTS

DU-56 DISCHI FRIZIONE

CAGIVA	CC	MY
CANYON	900	97
ELEFANT	900	91
ELEFANT CATALITICA	900	93
ELEFANT I.E.	900	91
DUCATI	CC	MY
748 BIPOSTO	748	95 97
748 DESMO 4	748	94
748 SP	748	95 97
748 SPS	748	98
749 BIPOSTO	748	98
900 SUPERLIGHT	900	92 96
M 900 MONSTER	904	93 99
M 900 MONSTER	904	00
M 900 MONSTER	904	01
SS 900	904	91 97
SS 900	904	98 00
907 I.E.	907	91
916 SP	916	94 97

916 STRADA	916	94 98
ST 4	916	99 00
ST 2	944	97 00
996 BIPOSTO	996	98 00

DU-97

SINTERIZZATO SECCO
SINTERED DRY CLUTCH



RICAMBI - SPARE PARTS

DU-74 DISCHI FRIZIONE

DUCATI	CC	MY
851 SP	851	91
851 STRADA	851	89
888 CORSA	888	91
888 DESMO 4	888	93 94
888 SPS	888	90 93
888 STRADA	888	94
888 SUPERBIKE	888	94 95
916 SPS	916	98
996 R	996	99 01
996 SPS	996	98 00
998 R	998	02
999 R	999	03

SERIE COMPLETA DISCHI FRIZIONE E RACING CLUTCH PLATES COMPLETE SET AND RACING

DU-104

BASE GOMMA BAGNO D'OLIO
RUBBER BASED WET CLUTCH



DUCATI	CC	MY
M 600 MONSTER	600	98 99
M 600 MONSTER	600	99 01
MONSTER DARK I.E.	618	03
MONSTER I.E.	618	02
MONSTER S I.E.	618	03
SS	618	03
M 750 MONSTER	750	98 99
M 750 MONSTER	750	99 01
SS 750	750	98 99
SS 750	750	00
SPORT	802	03
M 800 MONSTER DARK	803	03
M 800 MONSTER S I.E.	803	03
SS	803	03

RICAMBI - SPARE PARTS

DU-105

DISCHI FRIZIONE

DU-106

BASE GOMMA SECCO
RUBBER BASED DRY CLUTCH



DUCATI	CC	MY
748 R	748	00
748 R	748	01

RICAMBI - SPARE PARTS

DU-56

DISCHI FRIZIONE

DU-107

BASE GOMMA SECCO
RUBBER BASED DRY CLUTCH



BIMOTA	CC	MY
DB 5 MILLE	992	05
TESI II D	992	04 06
SB8 K SANTAMONICA	996	06
DUCATI	CC	MY
749	748	03
749 DARK	748	04
749 S	748	03
SS 900	904	01
MONSTER S4	916	01
ST 4	916	01 04
ST 2	944	01
PAUL SMART LIMITED	992	06
S2R	992	06
SPORT CLASSIC	992	06
ST 3	992	05 06
996 BIPOSTO	996	01
996 S	996	99 01
996 SPS	996	01
S4 R MONSTER	996	05 07
ST 4S	996	01 04
ST 4S-ABS	996	03 04

998	998	02
998 MATRIX	998	04
998 S	998	02
999	999	03
999 S	999	03
1000 HF I.E.	1000	03
1000 MULTISTRADA DS	1000	03
1000 SS I.E.	1000	03
MONSTER DARK I.E.	1000	03
MONSTER S I.E.	1000	03
S2 R MONSTER	1000	06

RICAMBI - SPARE PARTS

DU-113

DISCHI FRIZIONE

SERIE COMPLETA DISCHI FRIZIONE E RACING CLUTCH PLATES COMPLETE SET AND RACING

▶ DU-110 BASE GOMMA SECCO RUBBER BASED DRY CLUTCH

DUCATI	CC	MY
749 R	749	03



RICAMBI - SPARE PARTS

DU-114 DISCHI FRIZIONE

▶ DU-112 BASE GOMMA BAGNO D'OLIO RUBBER BASED WET CLUTCH

DUCATI	CC	MY
M620	618	05
M620 DARK	618	05
MONSTER S I.E.	618	03
SS	618	04
695 MONSTER	695	06
696 MONSTER	696	08
796 HYPERMOTARD	796	10
796 MONSTER	796	13
M 800 MONSTER DARK	803	03
M 800 MONSTER S I.E.	803	03
S2 R	803	05
S2 R DARK	803	05



RICAMBI - SPARE PARTS

DU-111 DISCHI FRIZIONE

▶ DU-117 BASE GOMMA SECCO RUBBER BASED DRY CLUTCH

BIMOTA	CC	MY
DB 5	1078	06 07
DB 6 DELIRIO	1078	07

DUCATI	CC	MY
HYPERMOTARD	1078	07 09
1098	1099	07 08
1098 S	1099	07 08
1098 TRICOLORE	1099	07

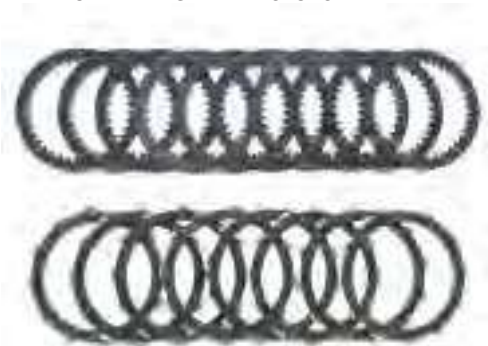

RICAMBI - SPARE PARTS

DU-116 DISCHI FRIZIONE

SERIE COMPLETA DISCHI FRIZIONE E RACING CLUTCH PLATES COMPLETE SET AND RACING

DU-118

BASE GOMMA SECCO
RUBBER BASED DRY CLUTCH

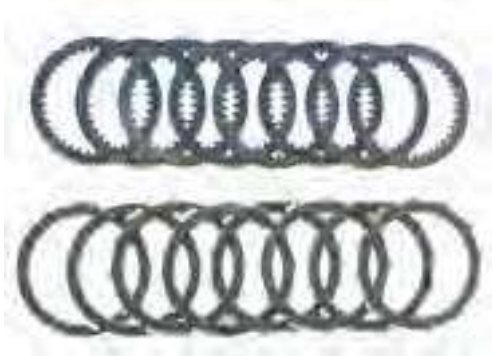

BIMOTA	CC	MY
DB 5 R	1078	06 07
TESI III D	1078	07
DUCATI	CC	MY
HYPERMOTARD S	1078	07 09
1098 R	1099	07

RICAMBI - SPARE PARTS

DU-116 DISCHI FRIZIONE

DU-119

BASE GOMMA SECCO
RUBBER BASED DRY CLUTCH

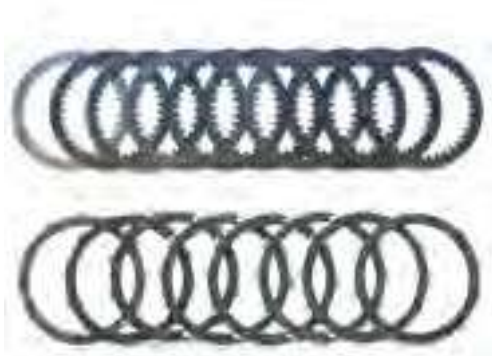

DUCATI	CC	MY
HYPERMOTARD	1078	10
HYPERMOTARD S	1078	10
1098	1099	09
1098 S	1099	09
STREETFIGHTER	1099	10
1198 S	1198	09
1198	1199	09

RICAMBI - SPARE PARTS

DU-116 DISCHI FRIZIONE

DU-125

BASE GOMMA BAGNO D'OLIO
RUBBER BASED WET CLUTCH

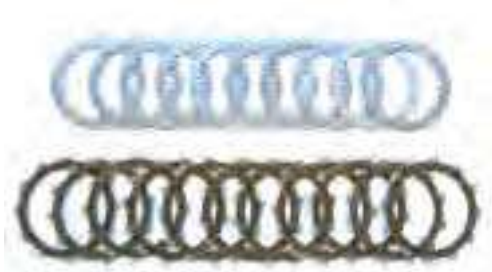

DUCATI	CC	MY
HYPERMOTARD	821	13
HYPERMOTARD SP	821	13
HYPERSTRADA	821	13
MONSTER	821	14
MONSTER DARK	821	14

RICAMBI - SPARE PARTS

DU-124 DISCHI FRIZIONE

SERIE COMPLETA DISCHI FRIZIONE E RACING CLUTCH PLATES COMPLETE SET AND RACING

▶ DU-127

BASE GOMMA BAGNO D'OLIO
RUBBER BASED WET CLUTCH

DUCATI	CC	MY
SCRAMBLER	800	14



RICAMBI - SPARE PARTS

DU-126 DISCHI FRIZIONE

▶ DU-129

BASE GOMMA BAGNO D'OLIO
RUBBER BASED WET CLUTCH

DUCATI	CC	MY
SCRAMBLER	400	14



RICAMBI - SPARE PARTS

DU-128 DISCHI FRIZIONE

▶ FB-14

BASE GOMMA BAGNO D'OLIO
RUBBER BASED WET CLUTCH

MINARELLI	CC	MY
EZ V1	50	89

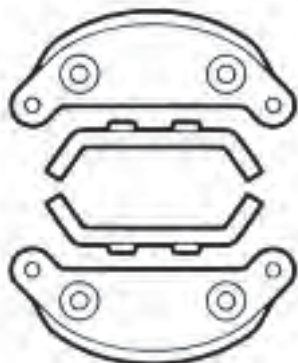

SERIE COMPLETA DISCHI FRIZIONE E RACING CLUTCH PLATES COMPLETE SET AND RACING

FB-107

BASE GOMMA BAGNO D'OLIO
RUBBER BASED WET CLUTCH

MINARELLI	CC	MY
P 4 (MOD. ADIGE)	50	88



FB-123/C

BASE GOMMA BAGNO D'OLIO
RUBBER BASED WET CLUTCH



APRILIA	CC	MY
AF 1	50	85
AF 1 AE	50	86
ET	50	85
ET AE	50	87
RED ROSE	50	88 91
RX	50	90 91
TUAREG	50	85
TUAREG	50	86
TUAREG	50	87 90
LAVERDA	CC	MY
GAUCHO	50	90
OR ATLAS	50	89
OR ATLAS ADVENTURE	50	88
MALAGUTI	CC	MY
DUNE ES-KS	50	89
MEX	50	86
MRX	50	89

RST	50	90
MINARELLI	CC	MY
C4	50	89
DL 3	50	89
DL 4	50	89
P 4	50	88
P 6	50	88
RV 3 (CILINDRO APRILIA)	50	89
RV 3 (CILINDRO ORIGINALE)	50	89
RV 4 (CILINDRO APRILIA)	50	89
RV 4 (CILINDRO ORIGINALE)	50	89
RV 6 (CILINDRO APRILIA)	50	89

FB-139

BASE GOMMA BAGNO D'OLIO
RUBBER BASED WET CLUTCH

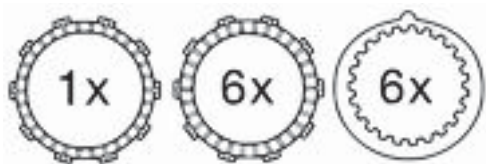

RICAMBI - SPARE PARTS

FB-127

DISCHI FRIZIONE

KTM	CC	MY
LC 2	125	98 00
RIEJU	CC	MY
MRX	125	03
SMX	125	03
YAMAHA	CC	MY
DT R	125	88 03
DT RE	125	04
DT RE	125	05 07
DT X	125	05
TDR	125	89 92
TDR R	125	93 03
TZR	125	93

TZR RR	125	94
TZR R	150	00
WR D/E/F	200	92 94
YFS B/F-H/J-N/P/R-T	200	91 02
YFS R/S/T	200	03 05

SERIE COMPLETA DISCHI FRIZIONE E RACING CLUTCH PLATES COMPLETE SET AND RACING

FB-140/C

BASE GOMMA BAGNO D'OLIO
RUBBER BASED WET CLUTCH



RICAMBI - SPARE PARTS

FB-132/M

DISCHI FRIZIONE

APRILIA	CC	MY
AF 1 FUTURA	50	91
CLASSIC	50	96
EUROPA	50	91
MX SUPERMOTARD	50	02
PEGASO	50	94
RED ROSE	50	92
RS	50	96 99
RS	50	00 06
RS EXTREMA	50	94
RS REPLICA	50	99
RX	50	92 97
RX	50	98
RX C-CD	50	93
RX RACING	50	04 06
RX RACING	50	07
SX	50	06
TUAREG	50	91
TUAREG RALLY	50	90
TUAREG WIND	50	90
TUONO	50	04
CLASSIC	80	93
BETA	CC	MY
RK 6 ENDURO	50	97 02
RK 6 T SUPERMOTARD	50	00
RR	50	00 05
RR - T	50	03
RR ENDURO ALU	50	03
RR ENDURO ALU	50	04 07
RR MOTARD ALU	50	03

RR MOTARD ALU	50	04 07
HM	CC	MY
CRE BAJA	50	01 02
CRE BAJA	50	03 06
CRE ENDURO	50	99
DERAPAGE	50	01 02
DERAPAGE	50	03 06
SIX	50	03 06
MALAGUTI	CC	MY
DRAKON	50	06
XSM SUPERMOTARD	50	03
XTM	50	03
MBK	CC	MY
X-LIMIT	50	00
MINARELLI	CC	MY
AM 345	50	91
RIEJU	CC	MY
MRX PRO	50	05
MRX RACING	50	02
NKD	50	05
RACING SPECIAL EDITION	50	01
RS1 CASTROL	50	01
RS2 MATRIX	50	03
SMX	50	02
SPIKE	50	02
SPIKE RACING	50	02
YAMAHA	CC	MY
DT R	50	97 01
DT R	50	02 04

FB-140

BASE GOMMA BAGNO D'OLIO
RUBBER BASED WET CLUTCH



RICAMBI - SPARE PARTS

FB-132

DISCHI FRIZIONE

APRILIA	CC	MY
AF 1 FUTURA	50	91
CLASSIC	50	96
EUROPA	50	91
MX SUPERMOTARD	50	02
PEGASO	50	94
RED ROSE	50	92
RS	50	96 99
RS	50	00 06
RS EXTREMA	50	94
RS REPLICA	50	99
RX	50	92 97
RX	50	98
RX C-CD	50	93
RX RACING	50	04 06
RX RACING	50	06
TUAREG	50	91
TUAREG RALLY	50	90
TUAREG WIND	50	90
TUONO	50	04
CLASSIC	80	93
BETA	CC	MY
RK 6 ENDURO	50	97 02
RK 6 T SUPERMOTARD	50	00
RR	50	00 05
RR - T	50	03
RR ENDURO ALU	50	03
RR ENDURO ALU	50	04 07
RR MOTARD ALU	50	03

RR MOTARD ALU	50	04 07
HM	CC	MY
CRE BAJA	50	01 02
CRE BAJA	50	03 06
CRE ENDURO	50	99
DERAPAGE	50	01 02
DERAPAGE	50	03 06
SIX	50	03 06
MALAGUTI	CC	MY
DRAKON	50	06
XSM SUPERMOTARD	50	03
XTM	50	03
MBK	CC	MY
X-LIMIT	50	00
MINARELLI	CC	MY
AM 345	50	91
RIEJU	CC	MY
MRX PRO	50	05
MRX RACING	50	02
NKD	50	05
RACING SPECIAL EDITION	50	01
RS1 CASTROL	50	01
RS2 MATRIX	50	03
SMX	50	02
SPIKE	50	02
SPIKE RACING	50	02
YAMAHA	CC	MY
DT R	50	97 01
DT R	50	02 04

SERIE COMPLETA DISCHI FRIZIONE E RACING CLUTCH PLATES COMPLETE SET AND RACING

FM-54/C

BASE GOMMA BAGNO D'OLIO
RUBBER BASED WET CLUTCH



FANTIC	CC	MY
TRIAL 125.5	125	89
TRIAL 125.7	125	90
TRIAL 125.9	125	90
TRIAL	247	90
TRIAL	305	89
TRIAL	307	90
K ROO	309	91

GA-70

BASE GOMMA BAGNO D'OLIO
RUBBER BASED WET CLUTCH



GARELLI	CC	MY
CICLONE LC	50	86
SUPER CICLONE LC	50	91
TIGER XLE	50	86
URKA AC-LC	50	89
SAHEL	80	89

GI-105

BASE GOMMA BAGNO D'OLIO
RUBBER BASED WET CLUTCH



RICAMBI - SPARE PARTS

GI-102 DISCHI FRIZIONE

GILERA	CC	MY
A-E ARIZONA RZE	125	87
CCM APTS	125	87
ER	125	87
FAST BIKE	125	87
KZ	125	86
KZ ENDURANCE	125	88
MX 1	125	88
MXR	125	89
R 1	125	88
RC RALLY	125	88
RRT NEBRASKA	125	87
RTX	125	86
RV	125	84
RV ES	125	87
RVE A-E	125	87
RX ARIZONA	125	83
TX 1	125	88
X 1	125	89
XR 1	125	88
XR 2	125	89

ARIZONA	200	83
ER	200	87
FAST BIKE	200	87
RTX	200	86
RV A-E	200	87
RV ES	200	87
RX	200	83

SERIE COMPLETA DISCHI FRIZIONE E RACING CLUTCH PLATES COMPLETE SET AND RACING

GI-108

BASE GOMMA BAGNO D'OLIO
RUBBER BASED WET CLUTCH

GILERA	CC	MY
DAKOTA 4 T	350	86
ER	350	87
XRT	350	89



RICAMBI - SPARE PARTS

GI-81 DISCHI FRIZIONE

GI-123

BASE GOMMA BAGNO D'OLIO
RUBBER BASED WET CLUTCH

GILERA	CC	MY
NORDWEST	350	94
NORDWEST	600	91
RC	600	88
RC	600	89
RC 4 VALVOLE	600	91
RC R	600	92
RC R-COBRA	600	94
XRT	600	88
XRT	600	89



RICAMBI - SPARE PARTS

GI-121 DISCHI FRIZIONE

GI-129

BASE GOMMA BAGNO D'OLIO
RUBBER BASED WET CLUTCH

GILERA	CC	MY
APACHE	125	92
CRONO AE	125	91
CX-AE	125	91
FREESTYLE	125	92
GFR	125	93
RC	125	90
RC TOP RALLY	125	90
SATURNO PIUMA	125	90
SP 01	125	89
SP 02	125	90



RICAMBI - SPARE PARTS

GI-128 DISCHI FRIZIONE

SERIE COMPLETA DISCHI FRIZIONE E RACING CLUTCH PLATES COMPLETE SET AND RACING

▶ GS-1 BASE GOMMA BAGNO D'OLIO RUBBER BASED WET CLUTCH



GAS GAS	CC	MY
TXT PRO	125	02
TXT PRO	200	02
TXT PRO	250	02
TXT PRO	280	02
TXT PRO	300	02

▶ GS-5 BASE GOMMA BAGNO D'OLIO RUBBER BASED WET CLUTCH



GAS GAS	CC	MY
EC 2T	200	07
EC HOBBY 2T	200	07 08
EC 2T	250	07
EC 2T	300	07
EC SIX DAYS 2T	300	09
EC 4T	450	09
FSR 4T	450	07
EC 4T	515	09
FSR 4T	515	08

RICAMBI - SPARE PARTS

GS-4 DISCHI FRIZIONE

▶ HO-85 BASE GOMMA BAGNO D'OLIO RUBBER BASED WET CLUTCH



HONDA	CC	MY
NS-FG-FH-RK-RL	125	85 93
CB-RSA-RSD	250	81 84
CL-SC	250	82 84
XL-SB-RC	250	81 82
XR RB-RC-RD	250	81 82

RICAMBI - SPARE PARTS

HO-59 DISCHI FRIZIONE

SERIE COMPLETA DISCHI FRIZIONE E RACING CLUTCH PLATES COMPLETE SET AND RACING

▶ HO-87 BASE GOMMA BAGNO D'OLIO RUBBER BASED WET CLUTCH



HONDA	CC	MY
CRM R	125	90 99
NSR-FM-FN	125	88 89
NSR-FM-FN	125	90
NSR-FM-FN	125	91 03
VT-ED-EF EURO SPORT	500	82 88

RICAMBI - SPARE PARTS

HO-61 DISCHI FRIZIONE

▶ HO-99 BASE GOMMA BAGNO D'OLIO RUBBER BASED WET CLUTCH



HONDA	CC	MY
CR RD-RK	250	83 86
CR RD-RK	250	87 89
CR RD	480	83
CR RE-RG-RH-RJ-RK	500	84 86
XL-LMF-LMH-RMG	600	85 87
XL-RD-RE-RF-RG	600	83 87
XR RE-RH	600	83 87
XR RE-RH	600	88 90
XR RE-RH	600	91 93
XR RE-RH	600	94 99
FX VIGOR	650	99 03
NX DOMINATOR-T-K-L-M-N	650	87
SLR	650	97 98

RICAMBI - SPARE PARTS

HO-97 DISCHI FRIZIONE

▶ HO-101 BASE GOMMA BAGNO D'OLIO RUBBER BASED WET CLUTCH



HONDA	CC	MY
CR RH-J-K-L-M-N-P-R-S-T-X	125	94 00

HUSQVARNA	CC	MY
SM S	125	02
WR	125	95 05
WR	125	06
WRE	125	94 00
WRE	125	01
WXE	125	07

RICAMBI - SPARE PARTS

HO-100 DISCHI FRIZIONE

SERIE COMPLETA DISCHI FRIZIONE E RACING CLUTCH PLATES COMPLETE SET AND RACING

HO-101/C

BASE GOMMA BAGNO D'OLIO
RUBBER BASED WET CLUTCH



HONDA	CC	MY
CR RH-J-K-L-M-N-P-R-S-T-X	125	94 00
HUSQVARNA	CC	MY
SM S	125	02
WR	125	95 05
WR	125	06
WRE	125	94 00
WRE	125	01
WXE	125	07

HO-121

BASE GOMMA BAGNO D'OLIO
RUBBER BASED WET CLUTCH



HM	CC	MY
CRE R ENDURO	250	02 07
CRE R SUPERMOTARD	250	02 03
HONDA	CC	MY
CR RL-RM-RN-RP	250	90 93
CR RR-RX	250	94 01
CR RR-RX	250	02
CR RL-RM-RN-RP-RR-RS-RT	500	94 00

RICAMBI - SPARE PARTS

HO-119

DISCHI FRIZIONE

HO-183

BASE GOMMA BAGNO D'OLIO
RUBBER BASED WET CLUTCH



HM	CC	MY
CR MOTARD	125	04 06
CRE R ENDURO	125	04 07
CRE R SUPERMOTARD	125	02 03
CRE F ENDURO	250	04
CRF MOTARD	250	04 06
HONDA	CC	MY
CR RH-J-K-L-M-N-P-R-S-T-X	125	94 00
CRF R	250	04
KTM	CC	MY
SX-F	250	05 08
XC-F	250	06 08
XC-F-W	250	06 08

RICAMBI - SPARE PARTS

HO-182

DISCHI FRIZIONE

▶ HO-183/C

BASE GOMMA BAGNO D'OLIO
RUBBER BASED WET CLUTCH



HM	CC	MY
CR MOTARD	125	04 06
CRE R ENDURO	125	04 07
CRE R SUPERMOTARD	125	02 03
CRE F ENDURO	250	04
CRF MOTARD	250	04 06
HONDA	CC	MY
CR RH-J-K-L-M-N-P-R-S-T-X	125	94 00
CRF R	250	04
KTM	CC	MY
SX-F	250	05 08
XC-F	250	06 08
XC-F-W	250	06 08

▶ HU-37/C

BASE GOMMA BAGNO D'OLIO
RUBBER BASED WET CLUTCH



HUSQVARNA	CC	MY
TE LC	510	89

▶ HU-38

BASE GOMMA BAGNO D'OLIO
RUBBER BASED WET CLUTCH



HUSQVARNA	CC	MY
CR	250	92 95
WR	250	91 92
WR	260	91

RICAMBI - SPARE PARTS

HU-39 DISCHI FRIZIONE

SERIE COMPLETA DISCHI FRIZIONE E RACING CLUTCH PLATES COMPLETE SET AND RACING

HU-41

BASE GOMMA BAGNO D'OLIO
RUBBER BASED WET CLUTCH



RICAMBI - SPARE PARTS

HU-42

DISCHI FRIZIONE

HUSQVARNA	CC	MY
CR	125	92 95
CR	125	96 04
CR	125	05

HU-44

BASE GOMMA BAGNO D'OLIO
RUBBER BASED WET CLUTCH



HUSQVARNA	CC	MY
TE	610	92 94

HU-50

BASE GOMMA BAGNO D'OLIO
RUBBER BASED WET CLUTCH



RICAMBI - SPARE PARTS

HU-39

DISCHI FRIZIONE

CAGIVA	CC	MY
W 12	350	93
CANYON	500	96 00
RIVER	500	00
CANYON	600	96 99
RIVER	600	00
W 16	600	95
HUSQVARNA	CC	MY
CR	250	96 04
CR	250	05
WR	250	93 05
WR	250	06
TE	350	95 97
CR	360	92 93
CR	360	94
WR	360	92 93
WR	360	94
TE	410	94 05
TE	410	06
TC	610	95
TE	610	95 99
TE E	610	00 03

SERIE COMPLETA DISCHI FRIZIONE E RACING CLUTCH PLATES COMPLETE SET AND RACING

▶ HU-50/C

BASE GOMMA BAGNO D'OLIO
RUBBER BASED WET CLUTCH

CAGIVA	CC	MY
W 12	350	93
CANYON	500	96 00
RIVER	500	00
CANYON	600	96 99
RIVER	600	00
W 16	600	95
HUSQVARNA	CC	MY
CR	250	96 04
CR	250	05
WR	250	93 05
WR	250	06
TE	350	95 97
CR	360	92 93
CR	360	94
WR	360	92 93
WR	360	94
TE	410	94 05
TE	410	06

TC	610	95	
TE	610	95	99
TE E	610	00	03

▶ KT-36/C

BASE GOMMA BAGNO D'OLIO
RUBBER BASED WET CLUTCH



KTM	CC	MY
EXC-EGS-SX	125	95 97
GS	125	89 90
GS	125	91 92
GS	125	93
GS	125	94 97
MX	125	86 87
MX	125	88
MX	125	89 91
MX	125	92
RS	125	89
SX	125	93
SX	125	94 97

VC	125	87	
WMX	125	88	
XC	125	86	

▶ KT-63

BASE GOMMA BAGNO D'OLIO
RUBBER BASED WET CLUTCH



KTM	CC	MY
DUKE	620	95 98
DUKE II	620	99 02
LC 4 EXC-EGS-SX	620	94 02
LC4 SXC SUPERMOTO	620	98 02
SC	620	99
EXC	625	03
LC4 SUPERCOMPETITION	625	02
DUKE	640	99
LC 4 ADVENTURE R	640	98
LC 4 ENDURO	640	99
LC 4 SUPERMOTO	640	99 02
LC 4 SUPERMOTO	640	03
LC 4 SMC SUPERMOTO	660	03

SERIE COMPLETA DISCHI FRIZIONE E RACING CLUTCH PLATES COMPLETE SET AND RACING

▶ KT-64

BASE GOMMA BAGNO D'OLIO
RUBBER BASED WET CLUTCH

KTM	CC	MY
LC 4 EGS	400	94
MX	500	92
SX	500	93



▶ KT-66

BASE GOMMA BAGNO D'OLIO
RUBBER BASED WET CLUTCH

KTM	CC	MY
EXC	125	03
EXC	125	04 06
EXC-EGS-SX	125	98 03
EXE	125	00
SX	125	04
SX	125	98 03
EGS	200	99 02
EXC	200	98 02
EXC	200	03
EXC	200	04 06
SX	200	03
SX	200	04



▶ LV-35

BASE GOMMA BAGNO D'OLIO
RUBBER BASED WET CLUTCH

LAVERDA	CC	MY
668	650	92
HIDALGO	668	90
EL CID	700	90
BLACK STRIKE	750	00
FORMULA	750	00
SUPER SPORT	750	00



SERIE COMPLETA DISCHI FRIZIONE E RACING CLUTCH PLATES COMPLETE SET AND RACING

MA-84

BASE GOMMA BAGNO D'OLIO
RUBBER BASED WET CLUTCH



CAGIVA	CC	MY
ALETTA ORO S 2	125	86
CRUISER	125	87 88
FRECCIA	125	87
FRECCIA C 9	125	88
WMX	125	85
WMX GP	250	82

RICAMBI - SPARE PARTS

MA-66 DISCHI FRIZIONE

MA-85

BASE GOMMA BAGNO D'OLIO
RUBBER BASED WET CLUTCH



CAGIVA	CC	MY
BLUES	125	88
BLUES	125	93
ELEFANT	125	81 84
ELEFANT	125	85 87
ELEFANT 3	125	88
WSTX ALETTA ROSSA	125	83
ALETTA ELECTRA	200	83

RICAMBI - SPARE PARTS

MA-78 DISCHI FRIZIONE

MA-147

BASE GOMMA BAGNO D'OLIO
RUBBER BASED WET CLUTCH



CAGIVA	CC	MY
WMX	500	86

RICAMBI - SPARE PARTS

MA-146 DISCHI FRIZIONE

SERIE COMPLETA DISCHI FRIZIONE E RACING CLUTCH PLATES COMPLETE SET AND RACING

▶ MA-175/C

BASE GOMMA BAGNO D'OLIO
RUBBER BASED WET CLUTCH



CAGIVA	CC	MY
FRECCIA C 10	125	88
FRECCIA C 10 ANNIVERSARY	125	89
FRECCIA C 12 R	125	89
K 7	125	91
MITO	125	90 92
MITO EDDY	125	93
MITO SPORT PRODUCTION	125	91
N 90	125	91
PLANET	125	98 03
RAPTOR	125	03
ROADSTER	125	98 99
SUPER CITY	125	93 00
TAMANACO	125	89
W 8	125	92 98
W 8 PRO ACTION	125	91
WMX	125	88
WMX	125	90
ELEFANT	200	88

ELEFANT	200	89
LAVERDA	CC	MY
NAVARRO	125	90
TOLEDO	125	90

▶ MA-175

BASE GOMMA BAGNO D'OLIO
RUBBER BASED WET CLUTCH



RICAMBI - SPARE PARTS

MA-174

DISCHI FRIZIONE

CAGIVA	CC	MY
FRECCIA C 10	125	88
FRECCIA C 10 ANNIVERSARY	125	89
FRECCIA C 12 R	125	89
K 7	125	91
MITO	125	90 92
MITO EDDY	125	93
MITO SPORT PRODUCTION	125	91
N 90	125	91
PLANET	125	98 03
RAPTOR	125	03
ROADSTER	125	98 99
SUPER CITY	125	93 00
TAMANACO	125	89
W 8	125	92 98
W 8 PRO ACTION	125	91
WMX	125	88
WMX	125	90
ELEFANT	200	88
ELEFANT	200	89
LAVERDA	CC	MY
NAVARRO	125	90
TOLEDO	125	90

▶ MF-25/C

BASE GOMMA BAGNO D'OLIO
RUBBER BASED WET CLUTCH



MALAGUTI	CC	MY
FIFTY	50	89
FIFTY FULL CX	50	86
FIFTY TOP	50	89

SERIE COMPLETA DISCHI FRIZIONE E RACING CLUTCH PLATES COMPLETE SET AND RACING

▶ VE-247 BASE GOMMA BAGNO D'OLIO RUBBER BASED WET CLUTCH



PIAGGIO	CC	MY
APE TL 1 SERIE	50	
APE TL 2 SERIE	50	
VESPA	CC	MY
VESPA PK SPECIAL-XL	50	
VESPA SPECIAL	50	
VESPA PRIMAVERA	90	
VESPA	125	51 62
VESPA	125	63 72
VESPA ET3	125	
VESPA PK AUTOMATICA	125	86
VESPA PK SPECIAL-XL	125	
VESPA PK XL 2	125	
VESPA PRIMAVERA	125	80

▶ VE-346 BASE GOMMA BAGNO D'OLIO RUBBER BASED WET CLUTCH

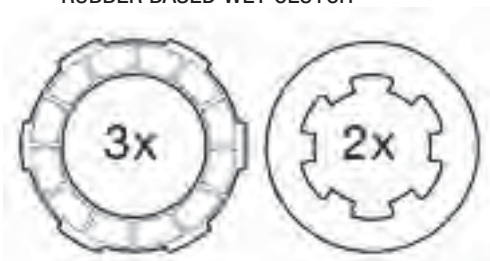

PIAGGIO	CC	MY
APE TL 1 SERIE	50	
APE TL 2 SERIE	50	
VESPA	CC	MY
VESPA PK SPECIAL-XL	50	
VESPA SPECIAL	50	
VESPA PRIMAVERA	90	
VESPA ET3	125	
VESPA PK AUTOMATICA	125	86
VESPA PK SPECIAL-XL	125	
VESPA PK XL 2	125	
VESPA PRIMAVERA	125	80

RICAMBI - SPARE PARTS

VE-160 DISCHI FRIZIONE

SERIE COMPLETA DISCHI FRIZIONE E RACING CLUTCH PLATES COMPLETE SET AND RACING

VE-364

BASE GOMMA BAGNO D'OLIO
RUBBER BASED WET CLUTCH

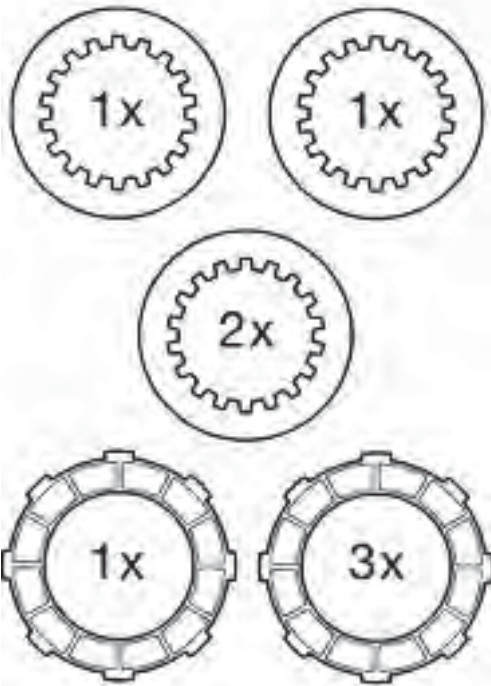

RICAMBI - SPARE PARTS

VE-362

DISCHI FRIZIONE

PIAGGIO	CC	MY
COSA II	125	92
COSA II	150	92
COSA II	200	92
VESPA	CC	MY
VESPA PX	150	98
VESPA PX	200	98

YA-70

BASE GOMMA BAGNO D'OLIO
RUBBER BASED WET CLUTCH



RICAMBI - SPARE PARTS

YA-43

DISCHI FRIZIONE

YAMAHA	CC	MY
DT	250	75 76
RD A-F	250	74 79
RD LC	250	80 82
TY D/E	250	77 78
RD A/B	350	74 75
RD LC	350	80 82
RD N/F/F2/R	350	85 95
RD YPVS	350	83 84
TT A (3GJ)	350	90 95
XT	350	85 95
YFZ U/A/B/D-N/P/R-T	350	90 05
DT	400	75 76
RD C/D/E/F	400	76 79

Frizioni Antisaltellamento APTC™

APTC™ è la frizione rivoluzionaria ed unica sul mercato ideata e brevettata da ADLER®. L'asservimento in coppia dell'APTC™ garantisce, oltre all'antisaltellamento in scalata, anche il massimo grip della ruota posteriore in fase di accelerazione, aiutando il pilota a mantenere il migliore assetto della moto e permettendo quindi una più rapida apertura del gas in uscita di curva.

Il mozzo dell'APTC™ realizzato in due parti connesse da un profilo elicoidale garantisce una leva frizione morbidissima (-50% del carico delle molle!) e nessuna pulsazione della leva in staccata. Il semplice set-up del pre-carico delle molle spingidisco con i distanziali in dotazione permette, inoltre, ad ogni pilota di trovare il setting personalizzato al proprio stile di guida, alle condizioni climatiche ed alle caratteristiche del tracciato.

Slippery Clutch APTC™

Revolutionary in design, unique to the market, the APTC™ slipper clutch is designed and patented by ADLER®. The power torque of the APTC™ slipper clutch assures the rider of both maximum rear-wheel grip during acceleration and anti-hopping during downshifting. By maximizing rider control, the APTC™ slipper clutch allows for greater speeds going into and coming out of turns.

The unique hub of the APTC™ consists of two parts connected by an helix profile. This design makes it much easier to pull the clutch lever (~50% less pressure is required!) and eliminates clutch lever vibration.

The simple set-up of the clutch springs pre-load with the three different types of included shims allows for greater customization possibilities by the rider.



VANTAGGI APTC™ RISPETTO ALLE NORMALI ANTISALTELLAMENTO:

- **ASSERVIMENTO IN COPPIA:**
la APTC™ agisce non solo in fase di frenata, ma anche in uscita di curva, in fase di accelerazione, permettendo una più rapida apertura del gas e garantendo maggiore trazione.
- **LEVA FRIZIONE MORBIDISSIMA:**
-50% del carico delle molle spingidisco rispetto alle frizioni standard di primo equipaggiamento
- **NESSUNA PULSAZIONE SULLA LEVA FRIZIONE:**
il funzionamento dell'APTC™ non viene percepito dal pilota sul manubrio.
- **FRIZIONE FORNITA DI DISCHI ED ASSEMBLATA:**
il tempo di montaggio della frizione sulla moto si riduce notevolmente.
- **DISTANZIALI DI SET UP FORNITI NEL KIT:**
l'APTC™ può essere regolata in base allo stile di guida del pilota o alle caratteristiche del tracciato semplicemente pre-caricando o scaricando le molle spingidisco con i distanziali in dotazione.

Per maggiori informazioni scarica il filmato su adigestore.com

Carter Frizione

Caratteristiche dei nuovi carter frizione ADIGE®:

- Realizzati con precisa lavorazione di macchina CNC da lega di alluminio T-6 anticorrosivo con alta resistenza agli agenti chimici
- Più resistenti degli originali, trattati con anodizzazione dura per una performance che duri a lungo nel tempo
- O-Ring in Viton per resistere anche alle più alte temperature
- "Channel Retainers" per una perfetta adesione dell'O-Ring al carter in modo da mantenere la frizione libera da sporco ed umidità
- Canali olio realizzati di lavorazione di macchina con imbuto direzionale per convogliare l'olio direttamente dove serve nella frizione ed aumentare la dissipazione del calore, preservando i dischi dall'usura precoce
- Loghi ADIGE® ed APTC™ realizzati di lavorazione di macchina

ADVANTAGES OF APTC™ COMPARED TO THE STANDARD SLIPPER CLUTCH:

- **POWER TORQUE:**
the APTC™ works: while downshifting, exiting a turn, during acceleration. This form of traction control allows for a far more rapid ascent to top speed.
- **SOFT-PULL CLUTCH LEVER:**
-50% less than standard clutch spring load.
- **NO CLUTCH LEVER VIBRATION:**
the rider will not be able to tell the APTC™ is working when he/she disengages the clutch.
- **CLUTCH IS FULLY ASSEMBLED WITH FRICTION PLATES:**
the only "assembly" required is the attaching of the clutch to the engine.
- **SETUP SHIMS ARE SUPPLIED:**
The rider can adjust the APTC to fit his/her riding style using the provided shims.

For more information download the video on adigestore.com

Clutch Covers

ADIGE® Clutch Cover features:

- Precision machined from T-6 billet anticorrosive aluminum with high resistance to chemical agents
- Stronger than stock, hard anodized for longer lasting performance
- Heat resistant Viton O-Ring with channel retainers for perfect seal to keep out dirt and moisture
- Special machined channels with extra-long directional funnel to direct oil back into clutch for better heat dissipation
- Precision machined ADIGE® & APTC™ logos

Le Frizioni Antisaltellamento APTC™ e i Carter Frizione sono ad uso agonistico sportivo per utilizzo esclusivo su pista. Slippery Clutch APTC™ and Clutch Covers are for racetrack use only; not for use on public road.

FRIZIONE ANTISALTELLAMENTO APTC SLIPPER CLUTCHES APTC

▶ AP-7

APRILIA	CC	MY
RXV ENDURO	450	06
SXV SUPERMOTARD	450	06
RXV ENDURO	550	06
SXV SUPERMOTARD	550	06

RICAMBI - SPARE PARTS

HO-200	DISCHI FRIZIONE
HO-191/4	KIT MOLLE + RONDELLE
HO-191/6	SISTEMA ANTI-JUDDERING

▶ DU-108



RICAMBI - SPARE PARTS

DU-108/1	DISCHI FRIZIONE
-----------------	-----------------

DUCATI	CC	MY
748 BIPOSTO	748	95 97
748 DESMO 4	748	94
748 R	748	00
748 R	748	01
748 SP	748	95 97
748 SPS	748	98
749 BIPOSTO	748	98
851 SP	851	91
851 STRADA	851	89
888 CORSA	888	91
888 DESMO 4	888	93 94
888 SPS	888	90 93
888 STRADA	888	94
888 SUPERBIKE	888	94 95
900 SUPERLIGHT	900	92 96
M 900 MONSTER	904	93 99
M 900 MONSTER	904	00
M 900 MONSTER	904	01
SS 900	904	91 97
SS 900	904	98 00
PASO	906	89
907 I.E.	907	91

916 SP	916	94	97
916 SPS	916	98	
916 STRADA	916	94	98
ST 4	916	99	00
ST 2	944	97	00
996 BIPOSTO	996	98	00
996 R	996	99	01
996 SPS	996	98	00
S4 R	996	05	
998 R	998	02	
999 R	999	03	

FRIZIONE ANTISALTELLAMENTO APTC SLIPPER CLUTCHES APTC

▶ DU-109



RICAMBI - SPARE PARTS

DU-109/1 DISCHI FRIZIONE

DUCATI	CC	MY
749	748	03
749 DARK	748	04
749 S	748	03
749 R	749	03
SS 900	904	01
MONSTER S4	916	01
ST 4	916	01
ST 2	944	01
GT 1000 SPORT	992	06
PAUL SMART LIMITED	992	06
SPORT CLASSIC	992	06
ST 3	992	05
996 BIPOSTO	996	01
996 S	996	99 01
996 SPS	996	01
ST 4S	996	01
ST 4S-ABS	996	03
998	998	02
998 MATRIX	998	04

998 S	998	02
999	999	03
999 S	999	03
1000 HF I.E.	1000	03
1000 MULTISTRADA DS	1000	03
1000 SS I.E.	1000	03
MONSTER DARK I.E.	1000	03
MONSTER S I.E.	1000	03
HYPERMOTARD	1078	07 09
HYPERMOTARD S	1078	07 09
MULTISTRADA	1078	07
MULTISTRADA S	1078	07

▶ DU-115



RICAMBI - SPARE PARTS

DU-109/1 DISCHI FRIZIONE

DUCATI	CC	MY
1098	1099	07 08
1098 TRICOLORE	1099	07

▶ DU-120



RICAMBI - SPARE PARTS

DU-120/1 DISCHI FRIZIONE

DUCATI	CC	MY
HYPERMOTARD	1078	10
HYPERMOTARD S	1078	10
1098	1099	09
1098 S	1099	09
1098 TRICOLORE	1099	07
1198	1198	09
1198 S	1198	09

▶ GS-2

GAS GAS	CC	MY
FSE	450	05 06
FSR	450	07
FSR	515	08



RICAMBI - SPARE PARTS

GS-3 DISCHI FRIZIONE

▶ HO-192

HM	CC	MY
CRF MOTARD	450	04
CRM F R SUPERMOTO	450	07
CRM F X SUPERMOTO	450	07
CRM F X SUPERMOTO	490	07
HONDA	CC	MY
CRF R	450	02 08

RICAMBI - SPARE PARTS

HO-200 DISCHI FRIZIONE
HO-191/4 KIT MOLLE + RONDELLE
HO-191/6 SISTEMA ANTI-JUDDERING

FRIZIONE ANTISALTELLAMENTO APTC SLIPPER CLUTCHES APTC

▶ HO-193



HONDA	CC	MY
CRF R	250	04
CRF X	250	04

RICAMBI - SPARE PARTS

HO-204	DISCHI FRIZIONE
HO-193/4	KIT MOLLE + RONDELLE
HO-193/6	SISTEMA ANTI-JUDDERING

▶ HO-197



HONDA	CC	MY
TRX R	450	05

RICAMBI - SPARE PARTS

HO-196	DISCHI FRIZIONE
HO-191/4	KIT MOLLE + RONDELLE
HO-191/6	SISTEMA ANTI-JUDDERING

FRIZIONE ANTISALTELLAMENTO APTC SLIPPER CLUTCHES APTC

▶ HO-201



HM	CC	MY
CRE F ENDURO	450	02
CRE F X	490	07
HONDA	CC	MY
CRF X	450	05

RICAMBI - SPARE PARTS

HO-200	DISCHI FRIZIONE
HO-191/4	KIT MOLLE + RONDELLE
HO-191/6	SISTEMA ANTI-JUDDERING

▶ HO-207



HONDA	CC	MY
CRF R	450	09 12

RICAMBI - SPARE PARTS

HO-209	DISCHI FRIZIONE
HO-209/4	KIT MOLLE + RONDELLE
HO-209/6	SISTEMA ANTI-JUDDERING

FRIZIONE ANTISALTELLAMENTO APTC SLIPPER CLUTCHES APTC

▶ HO-212



HONDA	CC	MY
CRF R	450	13 16

RICAMBI - SPARE PARTS

HO-209	DISCHI FRIZIONE
HO-209/4	KIT MOLLE + RONDELLE
HO-209/6	SISTEMA ANTI-JUDDERING

▶ HU-52



HUSQVARNA	CC	MY
SM R	450	05 07
SM RR	450	07
TC	450	05 07
TE	450	05 07
SM R	510	05 07
TC	510	05 07
TE	510	05 07

RICAMBI - SPARE PARTS

HO-200	DISCHI FRIZIONE
HO-191/4	KIT MOLLE + RONDELLE
HO-191/6	SISTEMA ANTI-JUDDERING

FRIZIONE ANTISALTELLAMENTO APTC SLIPPER CLUTCHES APTC

▶ HU-53



HUSQVARNA	CC	MY
SM R	450	08 10
SM RR	450	08 10
TC	450	08 10
TE	450	08 10
SM R	510	08 10
TC	510	08 10
TE	510	08 10

▶ KA-48



KAWASAKI	CC	MY
KLX	450	06
KX F	450	06

RICAMBI - SPARE PARTS

HO-200	DISCHI FRIZIONE
HO-191/4	KIT MOLLE + RONDELLE
HO-191/6	SISTEMA ANTI-JUDDERING

▶ SU-93



SUZUKI	CC	MY
LT Z K5/K6/K7	450	05 07
RM Z K5/K6/K7	450	05 07

RICAMBI - SPARE PARTS

SU-93/4	KIT MOLLE + RONDELLE
SU-93/6	SISTEMA ANTI-JUDDERING

FRIZIONE ANTISALTELLAMENTO APTC SLIPPER CLUTCHES APTC

► SU-96



SUZUKI	CC	MY
LT Z	450	08
RM Z	450	08

RICAMBI - SPARE PARTS

SU-93/4 KIT MOLLE + RONDELLE

SU-93/6 SISTEMA ANTI-JUDDERING

► YA-121



YAMAHA	CC	MY
WR FR/FS	450	03 05
WR FT	450	06
YZ FR/FS	450	03 05
YZ FT	450	06

RICAMBI - SPARE PARTS

YA-121/4 KIT MOLLE + RONDELLE

YA-121/6 SISTEMA ANTI-JUDDERING

► YA-122



YAMAHA	CC	MY
WR FT	450	07 09
WR FT	450	10
YZ FT	450	07 09
YZ FT	450	10

RICAMBI - SPARE PARTS

YA-121/4 KIT MOLLE + RONDELLE

YA-121/6 SISTEMA ANTI-JUDDERING

▶ AP-8



APRILIA	CC	MY
RXV ENDURO	450	06
SXV SUPERMOTARD	450	06
RXV ENDURO	550	06
SXV SUPERMOTARD	550	06

▶ HO-198



HONDA	CC	MY
CRF R	250	04
CRF X	250	04

▶ HO-199

HM	CC	MY
CRF MOTARD	450	04
CRM F R SUPERMOTO	450	07
CRM F X SUPERMOTO	450	07
CRM F X SUPERMOTO	490	07

HONDA	CC	MY
CRF R	450	02 08
TRX R	450	05

▶ HO-203



HM	CC	MY
CRE F ENDURO	450	02
CRE F X	490	07

HONDA	CC	MY
CRF X	450	05

▶ HO-208



HONDA	CC	MY
CRF R	450	09 12
CRF R	450	13 16

▶ KT-74



KTM	CC	MY
SMR	450	08
SX-F	450	08
SX-F	500	08
SMR	560	08

▶ KT-76



KTM	CC	MY
EXC R	450	08
EXC R	530	08

▶ SU-94



SUZUKI	CC	MY
LT Z K5/K6/K7	450	05 07
RM Z K5/K6/K7	450	05 07

▶ SU-97



SUZUKI	CC	MY
LT Z	450	08
RM Z	450	08

▶ SU-98



SUZUKI	CC	MY
RM Z	250	09

▶ YA-123

YAMAHA	CC	MY
WR FR/FS	450	03 05
WR FT	450	06
WR FT	450	07 09
YZ FR/FS	450	03 05
YZ FT	450	06
YZ FT	450	07 09

▶ YA-125

YAMAHA	CC	MY
WR FT	450	10
YZ FT	450	10



Pastiglie Freno

L'esperienza nel campo delle competizioni ha permesso ad ADIGE® di produrre pastiglie freno capaci di soddisfare le aspettative anche dei piloti più esigenti.

Pronte, potenti ed affidabili, le pastiglie freno ADIGE® sono disponibili in cinque mescole studiate per diversi impieghi, tutte accomunate da alto livello qualitativo e grande affidabilità. Tutte le pastiglie ADIGE® sono prive di amianto.

Brake Pads

The experience in the racing field allows ADIGE® to produce brake pads that satisfy the expectations even of the most demanding riders.

Prompt, powerful and reliable the ADIGE® brake pads are available in five different compounds, designed for different utilization but all with the same high quality level and reliability. All ADIGE® brake pads are asbestos free.



ACX (ORO) SINTERIZZATA:

Prodotte con una miscela sinterizzata adatta sia all'utilizzo in pista sia all'uso stradale, le pastiglie ADIGE®ACX si distinguono per una maggiore durata e resistenza alle alte temperature, garantendo una frenata potente e modulabile.

Caratteristiche:

- Miscela sinterizzata ad alto coefficiente d'attrito
- Frenata potente, costante e progressiva
- Senza effetto Fade
- Bassa rumorosità
- Alta efficienza sia sull'asciutto che sul bagnato
- Alte prestazioni sia alle alte che alle basse temperature
- Grande efficienza frenante su tutti i tipi di circuito
- Non aggressiva sul disco freno

Consigliate per:

Moto stradali di grossa cilindrata, SBK, cross e supermoto.

Disco Freno Consigliato: Acciaio

ACX (GOLD) SINTERED:

Produced with a sintered compound suitable both for the racing use and for the street use, the ADIGE®ACX brake pads stand out for a longer life and resistance to high temperatures, assuring a powerful braking that can be perfectly modulated.

Features:

- *Sintered compound with high friction coefficient*
- *Powerful, unchanging and graduated braking*
- *Without Fade effect*
- *Low noise*
- *High efficiency both on dry and wet surfaces*
- *High performance at both high and low temperatures*
- *High braking efficiency on all kind of racetracks*
- *Low wear of the brake disc*

Suggested for:

big displacement motorcycles, SBK, motocross and supermoto bikes.

Suggested brake disc: steel brake discs.



ASX (NERA) ORGANICA STRADALE:

Tutte le pastiglie ADIGE della gamma scooter ASX sono prive di amianto e certificate KBA e ISO 9001:2000. Prodotte con una miscela semi-metallica, le pastiglie ADIGE®ASX hanno le seguenti caratteristiche:

- Componenti semi-metallici
- Frenata progressiva e modulabile
- Senza effetto Fade
- Bassa rumorosità
- Minima perdita di efficacia sul bagnato
- Non aggressiva sul disco freno

Consigliate per: Scooter, Moto stradali di piccola cilindrata e ATV

Disco Freno Consigliato: Acciaio e Ghisa

ASX (BLACK) ROAD ORGANIC:

All ADIGE ASX scooter brake pads are asbestos free and certified KBA e ISO 9001:2000. Produced with a organic compound, the ADIGE®ASX brake pads have the following features:

- *Organic compound*
- *Unchanging and graduated braking*
- *Without Fade effect*
- *Low noise*
- *Very low loss of effectiveness on wet terrains*
- *Low wear of the brake disc*

Suggested for: Scooter, small displacement motorcycles and ATV

Suggested Brake Disc: Steel and cast-iron brake discs



ATX (ROSSA) ORGANICA TRIAL:

Prodotte con una miscela semi-metallica e studiate specificatamente per l'utilizzo nel trial, le pastiglie ADIGE®ATX hanno le seguenti caratteristiche:

- Componenti semi-metallici
- Frenata progressiva e modulabile
- Senza effetto Fade
- Bassa rumorosità
- Non aggressiva sul disco

Consigliate per: Moto da Trial

Disco Freno Consigliato: Acciaio e Ghisa

ATX TRIAL SEMI-METALLIC:

Produced with a semi-metallic compound and specifically designed for the trial use, the ADIGE®ATX brake pads have the following features:

- *Semi-metallic compound*
- *Unchanging and graduated braking*
- *Without Fade effect*
- *Low noise*
- *Low wear of the brake disc*

Suggested for: Trial motorcycles

Suggested Brake Disc: Steel and cast-iron brake discs



PASTIGLIE FRENO BRAKE PADS

► P.003



ORGANICA STRADALE
ROAD ORGANIC
P.003ASX

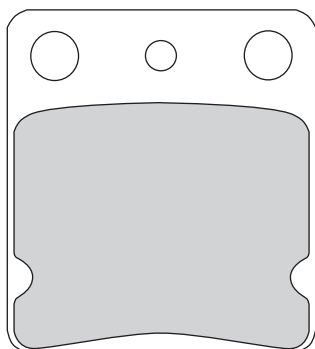

DAELIM	CC	MY	A	P
E-FIVE	50	03	•	
HISTORY-S-FIVE	50	01	•	•
TAPO	50	99	•	
VIVO	50	99	•	
DELFINO	100	99	01	•
FELLOW	125	97	•	
HISTORY	125	01	•	•

OTELLO DLX	125	00	02	•	•
HONDA	CC	MY	A	P	
MB SA-SB	50	80	82	•	
CR RE-F-2F-G-2G-H-T	80	84	89	•	
MBX FWD	80	83	86	•	
HUSQVARNA	CC	MY	A	P	
TE	610	92	94	•	

KAWASAKI	CC	MY	A	P
BN ELIMINATOR A1-A2	125	98	99	•
SUZUKI	CC	MY	A	P
RM K2-K3-K4	85	02	04	•
DR	200	93	98	•
DR G/H/J	200	86	89	•

► P.012



ORGANICA STRADALE
ROAD ORGANIC
P.012ASX

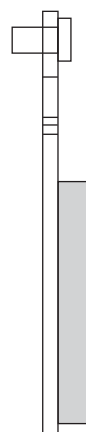
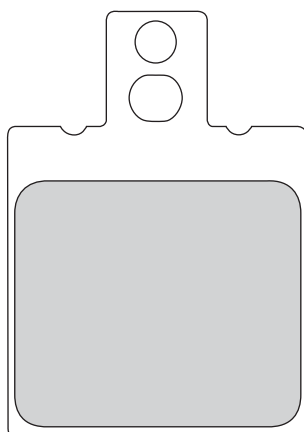

ALFER	CC	MY	A	P
MC	80	88	•	•
MC CROSS	80	89	•	•
MC	125	88		•
GR ENDURO	250	85	•	
MC	250	85	•	
GR ENDURO	300	85	88	•
TX	300	90		•
APRILIA	CC	MY	A	P
ET	50	85	•	•
SR R FACTORY	50	05	06	•
TUAREG	50	85	•	
TUAREG	50	87	90	•
AF 1 FUTURA	125	90		•
AF 1 REPLICA	125	89		•
AF 1 SINTESI	125	89		•
ETX	125	85	•	
EUROPA	125	91		•
PEGASO KAT	125	93		•
RED ROSE AE	125	91		•

RS	125	93	97	•	
RS	125	98	05	•	
RX	125	85		•	
SPORT PRO	125	93		•	
TUAREG WIND	125	89		•	
TUONO	125	04		•	
MX	250	83		•	
RX	250	83		•	
TUAREG RALLY	250	85		•	
ETX	350	85		•	
ETX AE	350	87		•	
TUAREG	350	85		•	
TUAREG WIND	350	87		•	
ETX AE	600	85		•	
BENELLI	CC	MY	A	P	
TORNADO	900	02		•	
BETA	CC	MY	A	P	
KR	50	86		•	
KR TWIN	50	88		•	
EIKON	125	00	05	•	

KR	125	86		•	
ALP	240	96		•	
AFRICA	250	86		•	
CR	250	83		•	
KR	250	86		•	
KR RALLY	250	87		•	
BIMOTA	CC	MY	A	P	
V DUE	500	98		•	
V DUE EVOLUTION	500	00		•	
BELLARIA	600	90		•	
YB9 SUPERSPORT	600	93		•	
DBI RS	750	87		•	
SB 6	750	94		•	
YB 4	750	87		•	
TESI ID	851	91		•	
DB 4	900	99		•	
MANTRA	900	95		•	
DB 2 H.F.-SR-INIEZIONE	904	93		•	
TESI I D SR-ES-EF	904	93		•	
TESI II D	992	04	06	•	

► P.012

BIMOTA	CC	MY	A	P
SB 8 R SPECIAL	996	99		•
SB8 K SANTAMONICA	996	06		•
DIECI BIPOSTO	1000	92		•
YB 6	1000	87		•
YB 8	1000	90		•
YB 8 EVOLUTION	1000	93		•
YB 8 EX UP	1000	91		•
YB 8 FURANO	1000	92		•
SB 6	1100	96		•
SB 7	1100	94		•
TUATARA	1100	90		•
YB 5	1200	87		•
CAGIVA	CC	MY	A	P
COCIS	50	88		•
K 3	50	92		•
LUCKY EXPLORER	50	88		•
SUPER CITY	50	92		•
W 4	50	92	95	•
PRIMA	75	92		•
LR	80	83		•
SUPER CITY	80	92		•
BLUES	125	88		•
FRECCIA	125	87		•
FRECCIA C 10	125	88		•
FRECCIA C 9	125	88		•
MITO	125	90	92	•
MITO EDDY	125	93		•
MITO SPORT PRODUCTION	125	91		•
PLANET	125	98	03	•
RAPTOR	125	03		•
SUPER CITY	125	93	00	•
WMX	125	85		•
ELEFANT	200	88		•
ALA BLU	250	83		•
MXR	250	82		•
SST ALA VERDE	250	81		•
VRX	250	83		•
WMX GP	250	82		•
ALA BLU	350	83		•
ALA ROSSA SXT	350	82		•
ALA VERDE SST	350	83		•
ALAZZURRA	350	84		•
ALAZZURRA GT	350	87		•
SX	350	83		•
W 12	350	93		•
ENDURO	500	86		•
MITO	500	07		•
RIVER	500	00		•
WMX	500	86		•
WMX	500	87		•
ALAZZURRA GT	650	87		•
ELEFANT	650	87		•
PARIGI DAKAR	650	86		•
TOURING	650	86		•
DAKAR	750	87		•
ELEFANT	750	87		•
LUCKY EXPLORER	750	88		•
DUCATI	CC	MY	A	P
F 3	350	87		•
INDIANA	350	87		•
SPORT	350	91		•
DESMO F 3	400	87		•
SS 400	400	93		•

SS JUNIOR	400	91		•
GTV	500	77		•
PANTAH	500	85		•
M 600 MONSTER	600	98	99	•
M 600 MONSTER	600	99	01	•
SS 600	600	94		•
SUPERMONO DESMO 4	600	93		•
DESMO	650	87		•
695 MONSTER	695	07		•
748 BIPOSTO	748	95	97	•
748 DESMO 4	748	94		•
748 R	748	00		•
748 SP	748	95	97	•
749 BIPOSTO	749	98		•
INDIANA	750	88		•
M 750 MONSTER	750	96	97	•
M 750 MONSTER	750	98	99	•
M 750 MONSTER	750	99	01	•
SS 750 SUPERSPORT	750	00		•
SPORT	802	03		•
SS	803	03		•
851 SP	851	91		•
851 STRADA	851	89		•
888 CORSA	888	91		•
888 DESMO 4	888	93	94	•
888 SPS	888	90	93	•
900 SUPERLIGHT	900	92	96	•
MH 900 (V3)	900	00		•
SL 900	900	92		•
M 900 MONSTER	904	93	99	•
SS 900	904	91	97	•
907 I.E.	907	91		•
916 SP	916	94	97	•
916 STRADA	916	94	98	•
996 BIPOSTO	996	01		•
996 R	996	01		•
996 S	996	99	01	•
996 SPS	996	98	00	•
996 SPS	996	01		•
998	998	02		•
998 R	998	02		•
998 S	998	02	06	•
MONSTER DARK I.E.	1000	03		•
FANTIC	CC	MY	A	P
CABALLERO RC-RS	50	92		•
GARELLI	CC	MY	A	P
TIGER XLE	50	86		•
TIGER XR-XRD	125	86		•
GILERA	CC	MY	A	P
RALLY	50	90		•
CCM APTS	125	87		•
CRONO AE	125	91		•
CX-AE	125	91		•
FAST BIKE	125	87		•
FREESTYLE	125	92		•
GFR	125	93		•
HX LC	125	83		•
KZ	125	86		•
KZ ENDURANCE	125	88		•
MX 1	125	88		•
MXR	125	89		•
R 1	125	88		•
RC	125	90		•
RV	125	84		•
RX ARIZONA	125	83		•
SP 01	125	89		•

SP 02	125	90		•
XR 1	125	88		•
XR 2	125	89		•
ARIZONA	200	83		•
FAST BIKE	200	87		•
RTX	200	86		•
RV A-E	200	87		•
RV ES	200	87		•
RX	200	83		•
AR ARIZONA RALLY	250	86		•
HX LC	250	83		•
N R G	250	87		•
NE	250	83		•
NX	250	83		•
RALLY	250	86		•
NORDWEST	350	94		•
XRT	350	89		•
SATURNO	500	89		•
NORDWEST	600	91		•
RC	600	88		•
RC R-COBRA	600	94		•
XRT	600	89		•
HONDA	CC	MY	A	P
NSR-FM-FN	125	88	89	•
NSR-RK-RL-RM-RN-RP-RR	125	89		•
HUSQVARNA	CC	MY	A	P
WR	250	84	90	•
KTM	CC	MY	A	P
MX	50	85		•
MX	80	92	01	•
PL-WATERCOOLED-MX	80	86		•
RLW-MX	80	80		•
MX	125	86	87	•
XC	125	86		•
GS-XC	300	86		•
GS 4-K 4-XC-MC	350	83		•
XC-MC	390	83		•
XC-MC	420	83		•
MX	500	86		•
XC-MC	500	83		•
XC	550	86		•
4T-GS-A-E	600	87		•
DUKE	640	99	02	•
LAVERDA	CC	MY	A	P
GAUCHO	50	90		•
OR ATLAS	50	86		•
OR ATLAS	50	89		•
OR ATLAS ADVENTURE	50	88		•
GS LESMO	350	86		•
RS-RF-ALPINO	350	77		•
RS-RF-ALPINO-MONTJUICH	500	77		•
668	650	92		•
BLACK STRIKE	750	00		•
FORMULA	750	00		•
SUPER SPORT	750	00		•
MALAGUTI	CC	MY	A	P
MDX	50	86		•
MALANCA	CC	MY	A	P
E 2C	80	82		•
E 2C-5 N-6 N	125	82		•
GT I	125	83		•
MARK	125	85		•
SPORT	125	83		•
MONTESA	CC	MY	A	P
COTA	309	89		•
COTA R	315	99	00	•

P.012

MONTESA	CC	MY	A	P
ENDURO H7	360	87	•	
MORINI	CC	MY	A	P
COUNTRY	250	88	•	
DART	350	88		•
KANGURO	350	88		•
NEW YORK	350	88		•
DART	400	89		•
S	400	95	•	•
CAMEL	501	88		•
COGUARO	501	89		•
EXCALIBUR	501	88		•
EXCALIBUR	501	89		•
IXE	501	88		•
NEW YORK	501	88	•	•
NEW YORK	501	89		•
MOTO GUZZI	CC	MY	A	P
BX	125	92	•	•
C	125	92	•	
TT-C	125	85	•	

TS	250	75	•	
FALCO	350	88	•	•
IMOLA	350	78	•	•
NEVADA	350	92	•	•
V 35 FLORIDIA III	350	92	•	•
V 35 I-II-III-C-TT	350	78	•	•
GTS	400	79	•	•
MONZA	500	78	•	•
V 50 I-II-III-MONZA CHOPER	500	80	•	•
V 50 POLIZIA MILITARE	500	80	•	•
GT SESSANTACINQUE	650	89	•	•
NTX	650	88	•	•
V 65 BAJA	650	86	•	•
V 65 C	650	85	•	•
V 65 FLORIDIA	650	86	•	•
V 65 LARIO	650	82	•	•
V 65 SP-TT-CHOPER-POLIZIA	650	76	•	•
V 65 TT	650	85	•	•
VT TT BAJA	650	86		•
BREVA I.E.	750	03		•
NEVADA CLUB	750	98 02	•	•
NTX	750	89	•	•

SP	750	92	•	•
STR V I.E.	750	03		•
TARGA	750	89	•	•
V 75	750	76	•	•
DAYTONA	1000	92		•
GRISO	1000	03		•
MILLE GT	1000	92		•
SPORT	1100	95		•
V 10 CENTAURO SPORT	1100	99		•
V 11 LE MANS	1100	03		•
V 11 SCURA	1100	03		•
V 11 SPORT	1100	00		•
MOTO TM	CC	MY	A	P
GS-MC	80	86 89		•
MUZ	CC	MY	A	P
SKORPION	500	94		•
PUCH	CC	MY	A	P
MAXI	80	88		•
YAMAHA	CC	MY	A	P
TZR RR	125	94		•
SZR	660	96 97		•

P.030

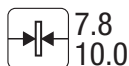

ORGANICA STRADALE
ROAD ORGANIC
P.030ASX

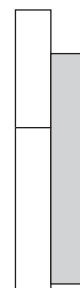
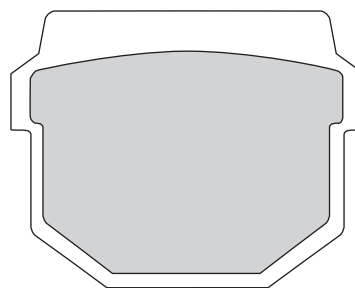
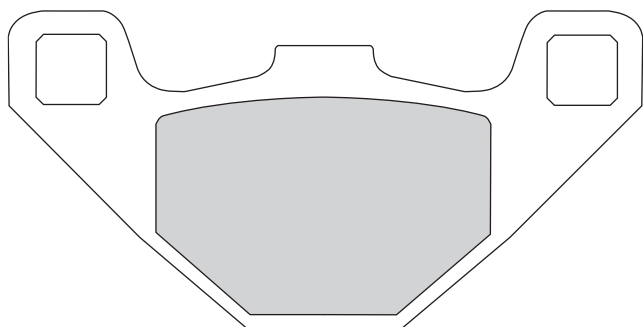

ADLY	CC	MY	A	P
NOBLE/THUNDERBIKE	50	07	•	
PANTHER	50	07	•	
THUNDERBIKE	150	07	•	•
HYOSUNG	CC	MY	A	P
SB M	50	06	•	
SD SENSE	50	06	•	
SF PRIMA	50	06	•	
KAWASAKI	CC	MY	A	P
AR A1-C1-C10	50	81 97	•	
AR A1-C1-C8	80	81 92	•	
KX E2	80	84 86	•	
KX E3-G1-G2-J1-J2	80	85 87	•	
KX L1-L2-L3/R1-R7	80	88 97	•	
KX A1-A2/B1-B7	100	89 97	•	

KDX A1-A2-B1-B2	125	91 94	•	
KMX A1-A2	125	86 87	•	
KMX A3-A4-A5	125	88 89	•	
KMX B1-B2	125	86 87	•	
KMX B2-B9	125	88 98	•	
KX B1	125	82	•	
KX B1	250	82	•	
KEEWAY	CC	MY	A	P
HURRICANE	50	06	•	
PEUGEOT	CC	MY	A	P
SPEEDFIGHT	50	96	•	
TREKKER OFF ROAD	50	97	•	
TREKKER ROAD	50	97	•	
SPEEDFIGHT	80	96	•	

PGO	CC	MY	A	P
COMET	50	91 95	•	
GALAXY	50	92	•	
PIAGGIO	CC	MY	A	P
TYPHOON	50	07 08	•	
TYPHOON SE	50	06	•	
SUZUKI	CC	MY	A	P
ADRESS	50	92	•	
SEPIA AU ZZ	50	96	•	
TUNE 50	50	93	•	
RM K/L	80	89 95	•	•
RM M/N/P/R/S/T/V/W/X/Y/K1	80	96 01	•	•
RM XG/XH/XJ	80	86 88	•	

PASTIGLIE FRENO BRAKE PADS

► P.045



ORGANICA STRADALE
ROAD ORGANIC
P.045ASX

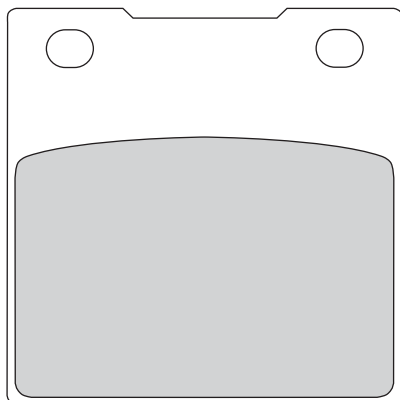

BIMOTA	CC	MY	A	P
YB 5 FS	1200	87		•
HONDA	CC	MY	A	P
CM-TA-TB CUSTOM	200	79	85	•
CB-RSA-RSD	250	81	84	•

CB-T-N-NA-NB	250	78	82	•	
CM-TB CUSTOM	250	82	84	•	
CM A/T	400	79		•	
CB	650	79	85	•	
CB-KZ	750	80		•	

SUZUKI	CC	MY	A	P
RG WD-WE GAMMA	250	83		•
GT A-B	500	76	77	•
GSX ESD-EE-ESE-EFE-ESG-ESH550	84	88		•

► P.057



ORGANICA STRADALE
ROAD ORGANIC
P.057ASX

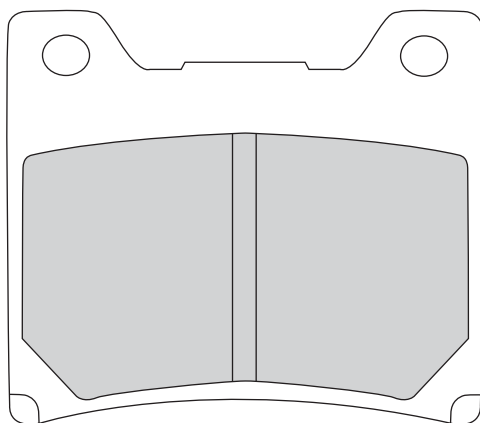

YAMAHA	CC	MY	A	P
TZR	125	90	92	•
RD YPVS	350	83	84	•
FZR GENESIS	400	86		•
XJR R	400	95	96	•
XJR R	400	97	00	•
RD LC YPVS	500	84	88	•
SR	500	78	82	•
XT	500	76	81	•
FZ	600	87	88	•
FZR	600	89		•
FZR R	600	90	93	•
FZR R	600	94	95	•
XJ	600	84	91	•
YX S/SC/T/TC/UC/UW/WC/A/AC	600	86	90	•
YZF R THUNDER CAT	600	96	03	•
FZX S/SC/T/TC FAZER	700	86	87	•

FZ	750	85	86	•	•
FZ	750	89	91	•	•
FZ	750	87	88	•	•
FZR GENESIS	750	87		•	•
FZR R OW01	750	89	90	•	•
FZX	750	87		•	•
XJ	750	82	83	•	•
YZF R/SP	750	93	97	•	•
TDM	850	91	95	•	•
TDM	850	96	01	•	•
TRX	850	96	98	•	•
XJ	900	83	90	•	•
XJ F	900	85	92	•	•
XJ S DIVERSION	900	95	03	•	•
FZR EX UP	1000	89	90	•	•
FZR GENESIS	1000	87	88	•	•
FZR R	1000	94		•	•

GTS	1000	93	96	•	•
XV VIRAGO	1000	86		•	•
YZF THUNDER ACE	1000	96	02	•	•
BT BULLDOG P/R/S/T	1100	02	05	•	•
FJ	1100	84	85	•	•
XV VIRAGO	1100	89	93	•	•
XV VIRAGO	1100	99	00	•	•
XVS A DRAG STAR CLASSIC	1100	00	05	•	•
XVS DRAG STAR	1100	99	04	•	•
FJ	1200	86	87	•	•
V MAX	1200	91	92	•	•
V MAX	1200	93	03	•	•
XJR	1200	95	98	•	•
XJR	1300	98		•	•
XJR/XJR SP	1300	99	01	•	•

PASTIGLIE FRENO BRAKE PADS

► P.062

	110.7		51.0		10.0
	70.0		43.5		10.0

ORGANICA STRADALE
ROAD ORGANIC
P.062ASX

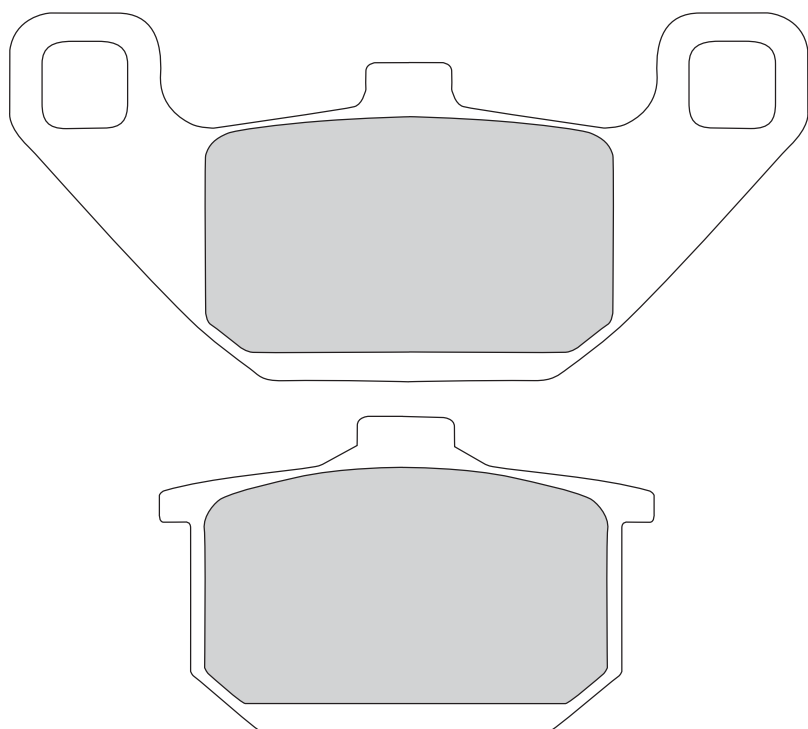

KAWASAKI	CC	MY	A	P
EL D1-D5	250	90 94	•	
ER B1-B2-B3 SCORPION	250	83 88	•	
EN A1-A6	450	85 90	•	
EN A1-A4/B1-B2/C1-C9	500	90 04	•	
GPZ R A1-A5	600	85 90	•	•
GPZ A1-A5	750	83 87	•	•
GPZ R1	750	82	•	•

VN A2-A13 VULCAN	750	86 06	•	
VN A1-A3	800	95 99	•	
GPZ R A1-A6	900	84 89	•	•
GPZ RX	1000	86 89	•	•
GPZ RY	1000	86 89	•	•
GTR	1000	86 93	•	•
GTR	1000	94 03		•
ZL A1-A2	1000	87 88	•	•

GPZ A1-A3	1100	83 88	•	•
ZG	1200	86 90	•	•
VN 15 SE	1500	93	•	•
VN CLASSIC	1500	96		•
VN SUMO	1500	94 96	•	•
VN VULCAN A1	1500	87	•	•
VN SUMO CLASSIC P.SX	1600	03		•

► P.063

	81.8		42.3		8.2
--	------	--	------	--	-----

SINTERIZZATA
SINTERED
P.063ACX

ORGANICA STRADALE
ROAD ORGANIC
P.063ASX

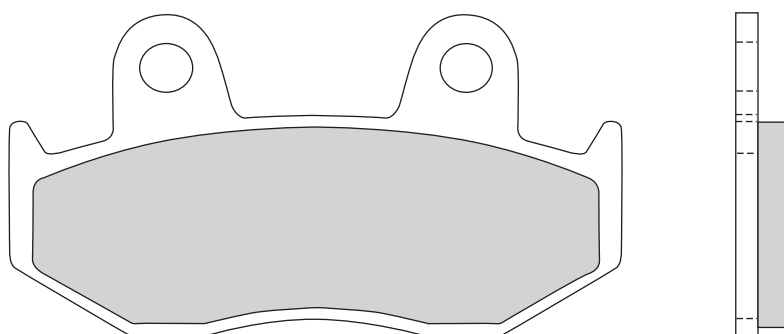

HONDA	CC	MY	A	P
CR RD-RE-RF-RG	125	83 86	•	
MTX RWF-RWH-RWL	125	83 87	•	
ATC RF-RG-RH	250	85 87	•	
CR RD-RK	250	83 86	•	
XL-RE RH PROLINK	250	84 88	•	
XL-SB-RC	250	81 82	•	
XR RE-RF	250	84 85	•	
XR RG-H-J-K-L-M-N-P-R-S	250	86 87	•	
CR RE-RG-RH-RJ-RK	500	84 86	•	
XL-RD-RE-RF-RG	600	83 87	•	
XR RE-RH	600	83 87	•	

SUZUKI	CC	MY	A	P
AN BURGMAN	250	98 03		•
AN BURGMAN	400	98 03		•

PASTIGLIE FRENO BRAKE PADS

► P.065



SINTERIZZATA
SINTERED
P.065ACX

ORGANICA STRADALE
ROAD ORGANIC
P.065ASX

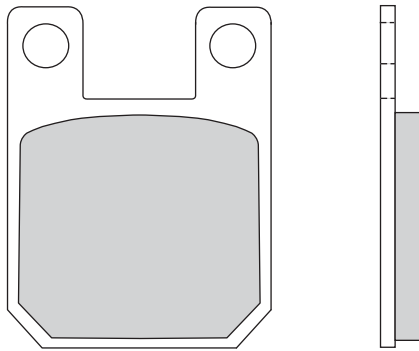

ALFER	CC	MY	A	P
TX	300	90	•	•
APRILIA	CC	MY	A	P
RS	50	07	•	•
SX	50	06	•	•
TX M	125	85	•	•
TX	240	86	•	•
CLIMBER	250	89	•	•
CLIMBER	250	90	•	•
CLIMBER R	250	92	•	•
REPLICA	250	92	•	•
CLIMBER R	280	93	•	•
TX M	300	86	•	•
TX M	311	85	•	•
TXR M	312	88	•	•
BETA	CC	MY	A	P
ALP	50	89 91	•	•
ALP	50	92 93	•	•
ALP	50	94	•	•
EIKON	50	99 06	•	•
KR	50	89	•	•
MX ENDURO	50	92	•	•
PRO RACE	50	05	•	•
REV	50	00 07	•	•
RK 6 ENDURO	50	97 02	•	•
RK 6 T SUPERMOTARD	50	00	•	•
RR	50	00 05	•	•
RR - T	50	03	•	•
RR ENDURO ALU	50	04 07	•	•
RR MOTARD ALU	50	04 07	•	•
SR 34	50	89	•	•
ST	50	94	•	•
SYNT	50	92	•	•
TR 34 CAMPIONATO	50	89	•	•
TR 35	50	89	•	•
ZERO	50	94	•	•
REV	80	00 07	•	•
ALP	125	00 04	•	•
SYNT	125	94	•	•
TR 34 R CAMPIONATO	125	89	•	•
TR 35	125	91	•	•
ZERO	125	92	•	•
ALP	200	00 04	•	•
ALP	200	00	•	•
ALP	240	96	•	•
ST	240	92	•	•
TR 35 REVERSE	240	89	•	•
ALP	250	97	•	•
TECHNO	250	94	•	•
SYNT	260	92 93	•	•

SYNT	260	94	•	•
TR 34 R CAMPIONATO	260	88	•	•
TR 34 R SUPER TRIAL	260	89	•	•
TR 35 REVERSE	260	90	•	•
ZERO	260	89 92	•	•
ZERO	260	98	•	•
ZERO GARA	260	93	•	•
EVO	290	09	•	•
DERBI	CC	MY	A	P
ATLANTIS	50	99	•	•
BLACK DEVIL	50	04	•	•
COPPA FDX	50	87	•	•
GP 1 L.C.	50	01 04	•	•
GP 1 L.C.	50	05	•	•
GPR R	50	97	•	•
PADDOCK	50	96	•	•
PREDATOR	50	99	•	•
PREDATOR 0.2	50	00	•	•
RECORD	50	98	•	•
SENDA	50	93 97	•	•
SENDA R DRD	50	02	•	•
SENDA SM DRD	50	02	•	•
SENDA SM DRD	50	03	•	•
SENDA SUPERMOTARD	50	98 01	•	•
SENDA X - TREM R	50	03	•	•
VARIANT SPORT R	50	94	•	•
ATLANTIS 0.2	100	00	•	•
GPR	125	05	•	•
GPR NUDE	125	05	•	•
SENDA 4T	125	04	•	•
SENDA X - TREM SM	125	04	•	•
FANTIC	CC	MY	A	P
CLUBMAN	50	95	•	•
K ROO	50	92	•	•
KET ROO	50	93	•	•
K ROO	80	92	•	•
TRIAL	80	92	•	•
K ROO	125	92	•	•
TRIAL 125.5	125	89	•	•
TRIAL 125.7	125	90	•	•
TRIAL 125.9	125	90	•	•
TRIAL	247	90	•	•
SECTION	249	95	•	•
TRIAL COACH	249	89	•	•
COACH	250	92 94	•	•
COACH	250	95	•	•
TRIAL	305	89	•	•
TRIAL	307	90	•	•
K ROO	309	91	•	•

GARELLI	CC	MY	A	P
SAHEL	80	89	•	•
TRIAL SECTION	125	95	•	•
TRIAL SECTION	249	95	•	•
TRIAL	323	86	•	•
GAS GAS	CC	MY	A	P
EC BOY	50	05	•	•
TXT BOY	50	04	•	•
MC	65	05	•	•
PAMPERA	125	96 02	•	•
JTX	200	95 98	•	•
CONTACT T 25	250	93	•	•
JT 25	250	91	•	•
JT CONTACT	250	94	•	•
JTR CONTACT	250	96	•	•
PAMPERA	250	03	•	•
JTX	270	95 98	•	•
TX	270	98	•	•
TXT	270	98	•	•
JT 32	320	91	•	•
PAMPERA	320	98 99	•	•
TRIAL	327	89	•	•
JTR CONTACT	370	96	•	•
GILERA	CC	MY	A	P
GP	50	03	•	•
GSM	50	00	•	•
SATURNO PIUMA	125	90	•	•
TRIAL	323	86	•	•
SATURNO PIUMA	500	90	•	•
HM	CC	MY	A	P
CRE BAJA	50	01 02	•	•
DERAPAGE	50	01 02	•	•
HUSQVARNA	CC	MY	A	P
SM	50	02	•	•
WR	50	02	•	•
WRS	50	98 00	•	•
ITALJET	CC	MY	A	P
DRAGSTER	50	98	•	•
TORPEDO 2T	50	00	•	•
TORPEDO NEW 4T	50	01	•	•
DRAGSTER L.C.	125	99	•	•
DRAGSTER L.C.	125	00 03	•	•
FORMULA	125	97	•	•
TORPEDO 4T	125	99 02	•	•
DRAGSTER L.C.	180	99	•	•
DRAGSTER L.C.	180	00 03	•	•
KTM	CC	MY	A	P
EXC	50	99	•	•
SX	60	99	•	•
SX	65	00 01	•	•

P.065

MALAGUTI				
CC	MY	A	P	
XSM SUPERMOTARD	50 03			•
MONTESA				
CC	MY	A	P	
COTA	304 86			•
COTA	307 87			•
COTA	309 89			•
COTA R	315 99 00			•
COTA	330 87			•
COTA	335 87			•
COTA TRIAL-EXCURSION	335 89			•
ENDURO H7	360 85			•
MOTORHISPANIA				
CC	MY	A	P	
MX FURIA	50 00			•
RX RACING	50 00 03			•
RYZ CROSS	50 04 05			•
RYZ ENDURO	50 05			•
RYZ SUPERMOTARD	50 04 05			•
PEUGEOT				
CC	MY	A	P	
ELISEO	50 98 02			•
ELISEO	50 03			•
ELISTAR	50 02 03			•
ELISTAR AVANTAGE 2	50 04			•
FOX	50 95			•
JET FORCE	50 03			•
LOOXOR	50 01			•
LUDIX BULLET	50 04			•
LUDIX ELEGANCE	50 04			•
LUDIX SNAKE	50 04			•
LUDIX TREND	50 04			•
SPEEDFIGHT ARIA	50 97			•

SPEEDFIGHT H2O	50 97			•
SQUAB	50 95			•
VIVACITY	50 99			•
XP S6 ENDURO	50 04			•
XP S6 SUPERMOTARD	50 04			•
XR 6	50 05			•
ZENITH	50 96			•
ELISEO	100 98 02			•
ELISEO	100 03			•
LOOXOR	100 02			•
SPEEDFIGHT	100 97			•
TREKKER ROAD	100 98			•
VIVACITY	100 99			•
LOOXOR	125 03			•
SATELIS K15	125 06			•
LOOXOR	150 03			•
PIAGGIO				
CC	MY	A	P	
DIESIS	50 02			•
DIESIS	100 01 03			•
PUCH				
CC	MY	A	P	
COBRA M 82	50 85			•
CONDOR	50 85			•
MONZA LUJO	50 85			•
MAXI	80 88			•
RIEJU				
CC	MY	A	P	
MRX PRO	50 05			•
MRX RACING	50 02			•
NKD	50 05			•
RACING SPECIAL EDITION	50 01			•
RS1 CASTROL	50 01			•
RS2 MATRIX	50 03			•
SMX	50 02			•

SPIKE	50 02			•
SPIKE RACING	50 02			•
MRX	125 03			•
SMX	125 03			•
SACHS				
CC	MY	A	P	
MAD ASS	50 05			•
SCORPA				
CC	MY	A	P	
TY-S F	125 06			•
TY-S F	175 06			•
2S5 WORKS	250 95			•
EASY RACE	280 99			•
SHERCO				
CC	MY	A	P	
125	125 99			•
2.0	200 99			•
2.5	250 99 01			•
2.9	290 99			•
SUZUKI				
CC	MY	A	P	
KATANA DD	50 99			•
ZILLION	50 99			•
TOMOS				
CC	MY	A	P	
STREETMATE	50 03 04			•
YAMAHA				
CC	MY	A	P	
DT R	50 02 04			•
DT R	50 04			•
DT X SUPERMOTARD	50 04			•
TZR	50 03 04			•
TY R	250 91 92			•
TY R	250 93 94			•

P.067



ORGANICA STRADALE
ROAD ORGANIC
P.067ASX

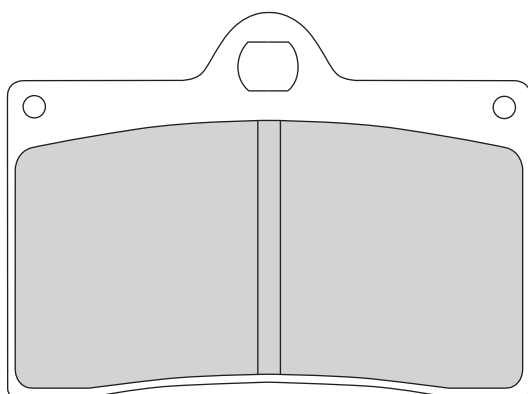

APRILIA				
CC	MY	A	P	
REPLICA	250 92			•
RS	250 95 97			•
BETA				
CC	MY	A	P	
JONATHAN	125 00 01			•
JONATHAN	125 02			•
EURO	350 03 06			•
JONATHAN	350 03 06			•
BIMOTA				
CC	MY	A	P	
V DUE	500 98			•
BELLARIA	600 90			•
YB9 SUPERSPORT	600 93			•
BBI SUPERMONO	650 95			•
DBI RS	750 87			•

SB 6	750 94			•
YB 4	750 87			•
TESI ID	851 91			•
MANTRA	900 95			•
DB 2 H.F. -SR-INIEZIONE	904 93			•
TESI I D SR-ES-EF	904 93			•
TESI II D	992 04 06			•
DIECI	1000 91			•
DIECI BIPOSTO	1000 92			•
YB 6	1000 87			•
YB 8	1000 90			•
YB 8 EVOLUTION	1000 93			•
YB 8 EX UP	1000 91			•
YB 8 FURANO	1000 92			•

SB 6	1100 96			•
CAGIVA				
CC	MY	A	P	
MITO EDDY	125 93			•
PLANET	125 98 03			•
RAPTOR	125 03			•
MITO	500 07			•
RIVER	500 00			•
RIVER	600 00			•
DUCATI				
CC	MY	A	P	
SPORT	350 91			•
SS 400	400 93			•
M 600 MONSTER	600 94 97			•
M 600 MONSTER	600 98 99			•
SS 600	600 94			•

PASTIGLIE FRENO BRAKE PADS

P.067

DUCATI	CC	MY	A	P
SUPERMONO DESMO 4	600	93	•	
748 BIPOSTO	748	95 97	•	
748 DESMO 4	748	94	•	
748 SP	748	95 97	•	
LAGUNA SECA	750	87	•	
M 750 MONSTER	750	96 97	•	
M 750 MONSTER	750	98 99	•	
SS 750 SUPERSPORT	750	00	•	
851 SP	851	91	•	
888 CORSA	888	91	•	
888 DESMO 4	888	93 94	•	
888 STRADA	888	94	•	
900 SUPERLIGHT	900	92 96	•	
SL 900	900	92	•	
SSR	900	92	•	
M 900 MONSTER	904	93 99	•	
SS 900	904	91 97	•	
907 I.E.	907	91	•	
916 SP	916	94 97	•	
916 STRADA	916	94 98	•	
ST 2	944	97 00	•	
GAS GAS	CC	MY	A	P
SM	125	02	•	
SM FSE	400	01 02	•	
FSR	450	07	•	

SM	450	03 06	•	
FSR	515	08	•	
GILERA	CC	MY	A	P
SATURNO PIUMA	125	90	•	
SATURNO	500	89	•	
HUSQVARNA	CC	MY	A	P
SM R	400	02	•	
SM R	450	03 06	•	
SM R	510	01 04	•	
SM R	570	01	•	
SM S	570	01	•	
SM R	610	00 05	•	
SMR	630	06	•	
ITALJET	CC	MY	A	P
GRIFON	900	00	•	
KTM	CC	MY	A	P
DUKE	600	93 95	•	
DUKE	620	95 98	•	
DUKE	640	99 02	•	
LAVERDA	CC	MY	A	P
668	650	92	•	
BLACK STRIKE	750	00	•	
FORMULA	750	00	•	
SUPER SPORT	750	00	•	
MOTO GUZZI	CC	MY	A	P
DAYTONA	1000	92	•	
CALIFORNIA I	1100	94	•	
CALIFORNIA JACKAL	1100	99	•	

CALIFORNIA SPECIAL	1100	99	•	
SPORT	1100	95	•	
V 10 CENTAURO SPORT	1100	99	•	
MOTO TM	CC	MY	A	P
SMR F ES	450	05	•	
SMR F ES	530	05	•	
SACHS	CC	MY	A	P
MAD ASS	125	05	•	
X ROAD	125	05	•	
XTC	125	99	•	
XTC N	125	99	•	
MAD ASS	500	05	•	
ROADSTER V 1.6	650	01	•	
ROADSTER V 2.0	800	00	•	
VERTEMATI	CC	MY	A	P
492 SUPERMOTARD	500	99	•	
VOR	CC	MY	A	P
492 SUPERMOTARD	500	00	•	
VOXAN	CC	MY	A	P
CAFE'RACER	1000	01	•	
ROADSTER	1000	01	•	
YAMAHA	CC	MY	A	P
TZR RR	125	94	•	
T MAX CUP	500	03	•	
SZR	660	96 97	•	

P.071



31.6



52.1



5.5

ORGANICA STRADALE
ROAD ORGANIC
P.071ASX

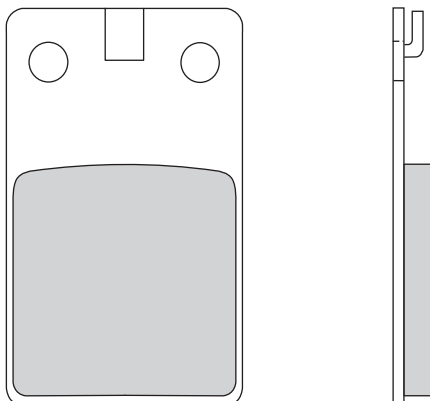

APRILIA	CC	MY	A	P
AF 1	50	85	•	
PEGASO	50	94		•
TUAREG RALLY	50	90	•	
TUAREG WIND	50	90	•	
BETA	CC	MY	A	P
RV	50	88	•	
TR 33	50	86	•	
TR 34	50	88	•	
TREKKING	50	88	•	
VRS	50	86	•	
TR 32	125	86	•	
TR 34	125	88	•	
TR 33	240	86	•	
TR 33 TREKKING	240	88	•	
TR 34	260	88	•	

FANTIC	CC	MY	A	P
CICLONE	50	94	•	
TRIAL H20	50	87	•	
PROFESSIONAL (FM 361)	125	87	•	•
TRIAL 125.1-125.2	125	87	•	
TRIAL	201	86	•	
TRIAL (FM 363)	243	87	•	•
TRIAL 301.1	301	86	•	
TRIAL (FM 364)	303	87	•	•
TRIAL 303.2	303	87	•	
GARELLI	CC	MY	A	P
FORMUNO RAID	50	89	•	
SUPER CICLONE LC	50	91	•	
URKA AC-LC	50	89	•	
GAS GAS	CC	MY	A	P
HALLEY PCX	325	87	•	•

GILERA	CC	MY	A	P
503	50	92	•	•
BULLIT	50	90	•	
MALAGUTI	CC	MY	A	P
CROSSER	50	99	•	
DUNE ES-KS	50	89		•
F 12 PHANTHOM	50	94	•	
FIFTY	50	89	•	
FIFTY FULL CX	50	86	•	
FIFTY TOP	50	89	•	
MGX	50	87	•	
MONTESA	CC	MY	A	P
ENDURO H7	360	86	•	
MOTRON	CC	MY	A	P
STING	50	95	•	

PASTIGLIE FRENO BRAKE PADS

► P.073



ORGANICA STRADALE
ROAD ORGANIC
P.073ASX

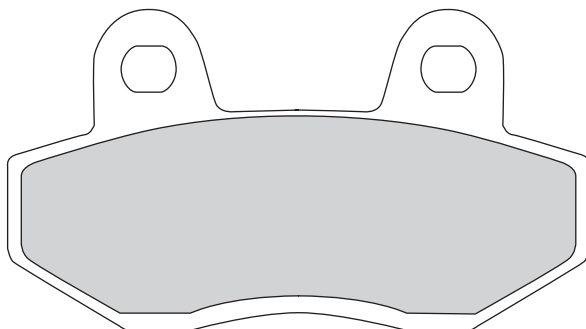

HONDA	CC	MY	A	P
NSR	75	90	•	
XL R	350	84 85	•	
HYOSUNG	CC	MY	A	P
MS3	125	06 07	•	•

GV	250	02	•	
MS3	250	06 07	•	•
GV AGUILA	650	04 05	•	
SACHS	CC	MY	A	P
MAD ASS	50	05	•	

SYM	CC	MY	A	P
WOLF LEGEND	125	02	•	

► P.074



ORGANICA STRADALE
ROAD ORGANIC
P.074ASX

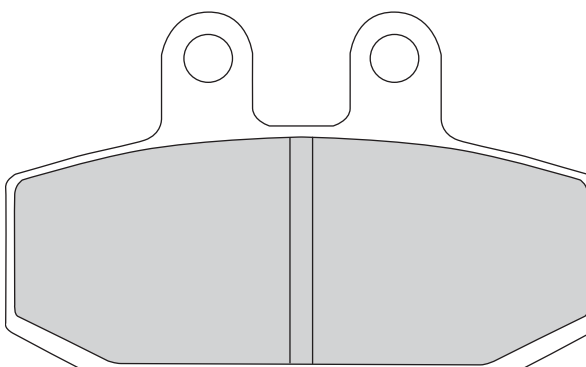

APRILIA	CC	MY	A	P
RX RACING	50	07	•	
SX	50	06	•	
CLASSIC	125	96 01	•	
ETX	125	86	•	
ETX PV	125	85	•	
RED ROSE	125	89	•	
RX	125	86 89	•	
SCARABEO	125	98 03	•	
SPORTCITY	125	05	•	
TUAREG RALLY	125	85 88	•	
SCARABEO	150	98 03	•	
SCARABEO	200	01 02	•	
SCARABEO GT	200	03 06	•	
SPORTCITY	200	05 06	•	
LEONARDO	250	99 00	•	
LEONARDO	250	01 04	•	
TUAREG RALLY	250	85	•	
ETX	350	85	•	
TUAREG WIND	350	87	•	
SCARABEO I.E.	400	07	•	
ATLANTIC	500	02 04	•	
SCARABEO ABS	500	03 06	•	
SCARABEO CLASS	500	10	•	
SCARABEO I.E.	500	07	•	
ETX AE	600	85	•	
MANA GT	850	09		•

CAGIVA	CC	MY	A	P
BLUES	125	88	•	
BLUES	125	93	•	
ALAZZURRA GT	650	87	•	
PARIGI DAKAR	650	86	•	
FANTIC	CC	MY	A	P
CABALLERO RC	80	94	•	
CABALLERO RC	125	94	•	
RAIDER (FM 259)	250	85	•	
GARELLI	CC	MY	A	P
HAWR	125	86	•	
TIGER XLE	125	87	•	
HAWR	200	86	•	
GILERA	CC	MY	A	P
A-E ARIZONA RZE	125	87	•	
CCM APTS	125	87	•	
ER	125	87	•	
FAST BIKE	125	87	•	
KZ	125	86	•	
KZ ENDURANCE	125	88	•	
R 1	125	88	•	
RC RALLY	125	88	•	
RRT NEBRASKA	125	87	•	
RTX	125	86	•	
RVE A-E	125	87	•	
TX 1	125	88	•	
X 1	125	89	•	

XR 1	125	88	•	
ER	200	87	•	
FAST BIKE	200	87	•	
RTX	200	86	•	
RV A-E	200	87	•	
RV ES	200	87	•	
RAIDER	250	86	•	
DAKOTA 4 T	350	86	•	
ER	350	87	•	
XRT	350	89	•	
DAKOTA	500	87	•	
ER	500	87	•	
RC	600	88	•	
XRT	600	88	•	
HONDA	CC	MY	A	P
BALI	50	93	•	
BALI	100	99	•	
CA S-T REBEL	125	99	•	
CRM R	125	90 99	•	
MTX RWF-RWH-RWL	125	88 94	•	
NS-FG-FH-RK-RL	125	85 93	•	
NSR-FM-FN	125	88 89	•	
NSR-FM-FN	125	91 03	•	
NSR-RK-RL-RM-RN-RP-RR	125	89	•	
KTM	CC	MY	A	P
ENDURO	125	88 91	•	•
GS	125	89 90	•	•

PASTIGLIE FRENO BRAKE PADS

P.074

KTM	CC	MY	A	P
MX	125	88		• •
ENDURO	250	88	91	• •
GS	250	88		• •
GS	250	89	90	• •
ENDURO	350	88		• •
MX	500	88		• •

ENDURO LC 4-INCAS	600	88		• •
MALAGUTI	CC	MY	A	P
MADISON R	125	06		• •
SPIDERMAX GT	500	04		• •
MORINI	CC	MY	A	P
EXCALIBUR	350	86		• •
KANGURO	350	88		• •
CAMEL	501	88		• •
EXCALIBUR	501	86		• •

EXCALIBUR	501	88		• •
MUZ	CC	MY	A	P
MASTIFF	660	00		• •
SACHS	CC	MY	A	P
ZX	125	99		• •
ZZ	125	99		• •

P.075

	85.0		42.1		37.2		8.0		10.0
	55.8								

ORGANICA STRADALE
ROAD ORGANIC
P.075ASX

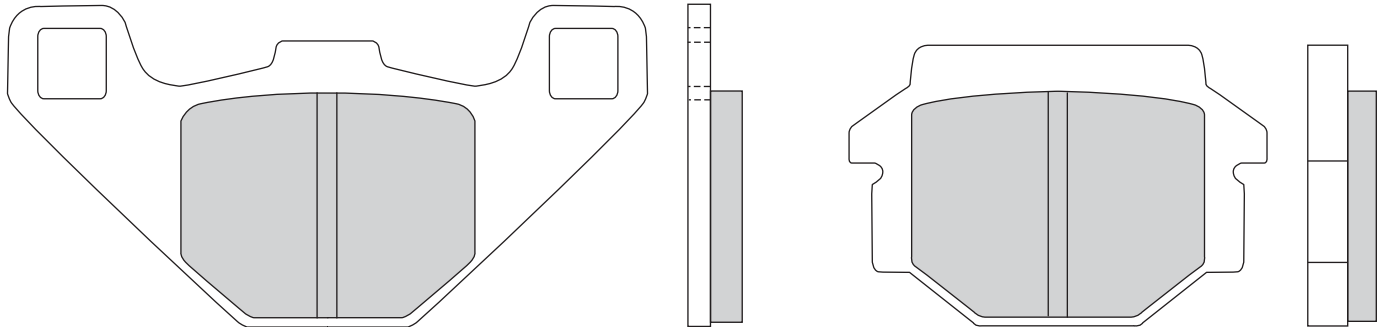

ALFER	CC	MY	A	P
AR	250	92		• •
AR	250	93		• •
VR	250	94		• •
APRILIA	CC	MY	A	P
PEGASO	125	89		• •
RX	125	90		• •
RX	125	92	93	• •
TUAREG WIND	350	89		• •
PEGASO 4 VALVOLE	600	91		• •
TUAREG WIND	600	89		• •
TUAREG WIND PARIGI DAKAR	600	89		• •
PEGASO	650	97	00	• •
CAGIVA	CC	MY	A	P
K 7	125	91		• •
WMX	125	90		• •
WMX	250	88		• •
WMX	250	91		• •
W 16	600	95		• •
FANTIC	CC	MY	A	P
TRIAL	50	92		• •
GAS GAS	CC	MY	A	P
CROSS	250	95		• •
HM	CC	MY	A	P
CRE ENDURO	50	99		• •
HUSABERG	CC	MY	A	P
MC	350	91	93	• •
CROSS	500	93		• •
MC	500	91		• •
MC	501	89	93	• •
MC ENDURO	501	91		• •
HUSQVARNA	CC	MY	A	P
WR	250	91	92	• •
WR	260	91		• •
CR	360	92	93	• •
TE LC	510	89		• •
ITALJET	CC	MY	A	P
MILLENNIUM 4T	125	00	01	• •
MILLENNIUM 4T	150	00	01	• •

KAWASAKI	CC	MY	A	P
KH G4	100	83		• •
KH G5/G8	100	84	87	• •
AR A1-A8-B1-B8	125	83	94	• •
KH K2-K10	125	83	98	• •
KH L1	125	83	86	• •
KMX A1-A2	125	86	87	• •
KMX A3-A4-A5	125	88	89	• •
KMX B1-B2	125	86	87	• •
KMX B10-B12	125	99	03	• •
KMX B2-B9	125	88	98	• •
KX B2/C1	125	83	84	• •
KX D1	125	85		• •
KX E1	125	86		• •
KX E2/F1	125	87	88	• •
KDX C1-C2-C3	200	86	88	• •
KDX E1-E2-E3-E4	200	89	92	• •
BJ ESTRELLA	250	92	98	• •
BJ ESTRELLA RS	250	99	02	• •
EX HI-H2	250	90		• •
KL SUPER SHERPA	250	97		• •
KR A1-A2	250	84	86	• •
KX C1	250	83	85	• •
KX D1	250	85		• •
KX D2	250	86		• •
KX E1-F1	250	87	88	• •
ZR A1-A5 BALIUS	250	91	95	• •
ZR B6 BALIUS II	250	02		• •
ZXR	250	91	95	• •
ZXR R	250	91		• •
ZZ-R	250	90	03	• •
KLF BI-B17 BAYOU	300	88	04	• •
ZR A1-B1	400	83	84	• •
GPZ S	500	94	04	• •
KLE A1-A12	500	91	04	• •
KX A1-A2	500	83	84	• •
KX B1-B2	500	85		• •
KX C1/D1	500	87	88	• •
GT G1-G9	550	83	01	• •

KLR B1-B2-B4-B6-B9	600	85	94	• •
KL B1 TENGAI-B2-B3	650	89	92	• •
KLR A1-A19	650	87	05	• •
KLR C1-C8	650	94	04	• •
KTM	CC	MY	A	P
ENDURO	125	92		• •
ENDURO	125	93		• •
GS	125	91	92	• •
GS	125	93		• •
MX	125	89	91	• •
MX	125	92		• •
SX	125	93		• •
ENDURO	250	92		• •
ENDURO	250	93		• •
EXC-EGS-SX	250	93	95	• •
GS	250	91	92	• •
GS	250	93		• •
MX	250	88		• •
MX	250	89		• •
SX-EGS-EXC	250	93	95	• •
ENDURO	300	92		• •
ENDURO	300	93		• •
GS	300	91		• •
SX-EGS-EXC	300	93		• •
MX	350	89	91	• •
MX	350	92		• •
MX	500	89	91	• •
MX	500	92		• •
SX	500	93		• •
4T GARA	600	91		• •
4T GS	600	93		• •
MC LC 4	600	90		• •
LAVERDA	CC	MY	A	P
HIDALGO	668	90		• •
EL CID	700	90		• •
MALAGUTI	CC	MY	A	P
MEX	50	86		• •
MFX	50	86		• •

P.075

MOTO TM	CC	MY	A	P
GS-MC	80	90 92		•
GS-MC	125	90 92		•
MUZ	CC	MY	A	P
BAGHIRA	660	00		•

MASTIFF	660	00		•
SUZUKI	CC	MY	A	P
OR ET	50	80		•
ZR SKX/SKE/SKH	50	83 87		•
ZR SLKX	50	81		•
GS ESR/ESX	125	95 00		•
GS ESZ	125	82		•

LT RJ-RK-RL	500	88 90		•
SYM	CC	MY	A	P
HUSKY	125	96 98		•

P.076



SINTERIZZATA
SINTERED
P.076ACX

ORGANICA STRADALE
ROAD ORGANIC
P.076ASX

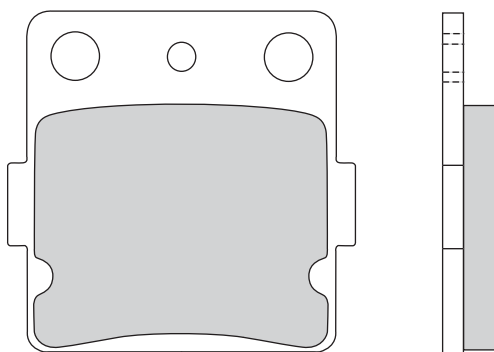

HONDA	CC	MY	A	P
CR RE-F-2F-G-2G-H-T	80	84 89		•
CR R	85	03		•
TRX EX	300	93 05		•
TRX E	400	99 02		•
HUSQVARNA	CC	MY	A	P
CR	125	92 95		•
CR	250	92 95		•
WR	360	92 93		•
KAWASAKI	CC	MY	A	P
KX	65	00		•
KX L1-L2-L3/R1-R7	80	88 97		•

KX W1-W2-W3	80	98 00		•
KX A1-A5/B1-B5	85	01 05		•
KX A1-A2/B1-B7	100	89 97		•
KX C1/C2/C3	100	98 01		•
SUZUKI	CC	MY	A	P
RM J	125	88		•
LT Z K4-K5-K6-K7	250	04 07		•
RM H	250	87		•
RM J/K/L/M	250	88		•
LT Z K3- K4-K5	400	03 05		•
YAMAHA	CC	MY	A	P
G/H/J/K/L/M/N	80	95 01		•

YZ	80	97 02		•
YZ E/LC/LW/F	80	93 94		•
YZ	85	02 07		•
YZ W	125	89		•
YFS R/S/T	200	03 05		•
YFM S/T RAPTOR	350	04 05		•
YFM XD-XS	350	92 04		•
YFZ U/A/B/D-N/P/R-T	350	90 05		•
YFM R RAPTOR	660	01 05		•

P.079



ORGANICA STRADALE
ROAD ORGANIC
P.079ASX

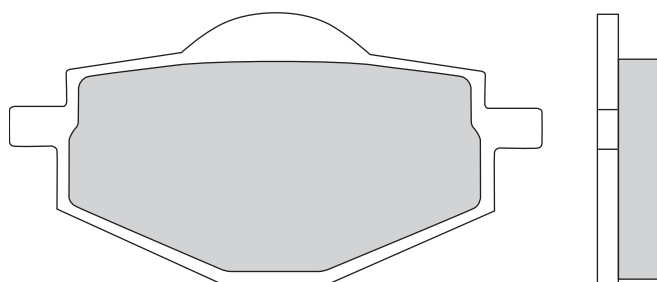

APRILIA	CC	MY	A	P
RC	125	89		•
BETA	CC	MY	A	P
EURO	350	03 06		•
JONATHAN	350	03 06		•
GILERA	CC	MY	A	P
APACHE	125	92		•
RC TOP RALLY	125	90		•
RC	600	89		•
RC 4 VALVOLE	600	91		•
RC R	600	92		•

MALAGUTI	CC	MY	A	P
CENTRO IE SL	125	09 10		•
CENTRO IE SL	160	09 10		•
MBK	CC	MY	A	P
FLAME	125	96 99		•
FLAME	125	00		•
VERTEX	150	97		•
YAMAHA	CC	MY	A	P
TZR THUNDERKID	50	97 00		•
TZR RR	80	89 97		•
CYGNUS R	125	96 02		•

DT R	125	88 03		•
DT RE	125	04		•
DT RE	125	05 07		•
TDR R	125	93 03		•
VINO	125	04		•
YJ 125 S/T/V/W/X VINO	125	04 08		•
YZ U	125	88		•
YZ U	250	88		•
XT	350	85 95		•
XT	600	87		•
XT E/ZE	600	90 03		•

PASTIGLIE FRENO BRAKE PADS

► P.079

YAMAHA	CC	MY	A	P
XT Z	600	89 90		•
XTZ TENERE	660	91 98		•

► P.082



SINTERIZZATA
SINTERED
P.082ACX

ORGANICA STRADALE
ROAD ORGANIC
P.082ASX

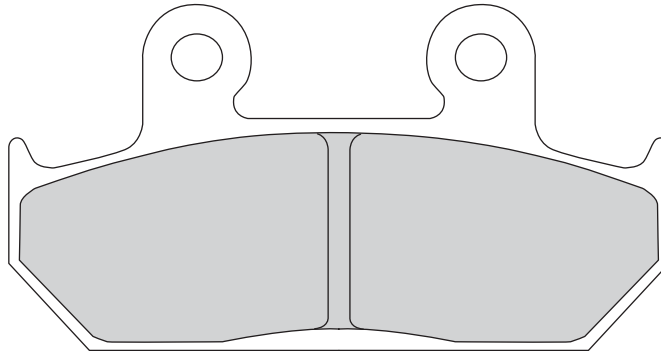

CAGIVA	CC	MY	A	P
CANYON	500	96 00	•	
CANYON	600	96 99	•	
ELEFANT	750	94	•	
ELEFANT	900	90	•	
ELEFANT	900	91	•	
ELEFANT I.E.	900	91	•	

ELEFANT	CC	MY	A	P
ELEFANT	906	89	•	
HONDA	CC	MY	A	P
CD-UJ-UK	250	88 93	•	
VT SHADOW-CN-CV	600	91 93	•	
XL TRANSALP-VH-VV	600	97 00	•	
NX DOMINATOR-T-K-L-M-N	650	87	•	
XRV AFRICA TWIN	650	88 89	•	

VFR F-F2	700	86 87	•	
VFR F	750	86 87	•	
CBR FH-FJ-FK-FL-FV	1000	87 88	•	
GL J-K-L SEN-SEV GOLDWING 1500	88	00	•	
KTM	CC	MY	A	P
RS	125	89	•	

► P.085



ORGANICA STRADALE
ROAD ORGANIC
P.085ASX

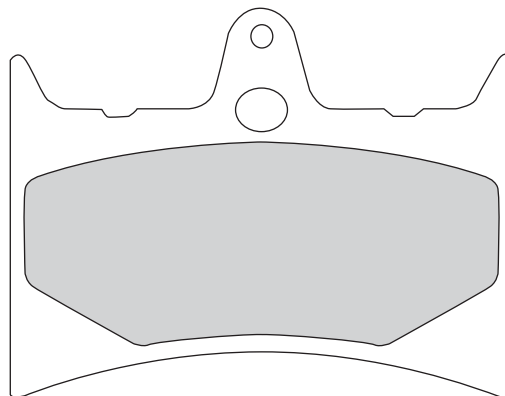

ALFER	CC	MY	A	P
MC	125	88	•	
GR ENDURO	300	89	•	
APRILIA	CC	MY	A	P
AF 1 SINTESI	125	89	•	
EUROPA	125	91	•	
PEGASO KAT	125	93	•	
RS	125	93 97	•	
RS	125	98 05	•	
SPORT PRO	125	93	•	
TUONO	125	04	•	
BETA	CC	MY	A	P
EURO	350	00 01	•	
EURO	350	02	•	
BIMOTA	CC	MY	A	P
YB 7	400	89	•	
YB 4	750	89	•	

YB 6	1000	89	•	
DUCATI	CC	MY	A	P
851 STRADA	851	89	•	
GILERA	CC	MY	A	P
CRONO AE	125	91	•	
CX-AE	125	91	•	
FREESTYLE	125	92	•	
GFR	125	93	•	
MX 1	125	88	•	
MXR	125	89	•	
SP 01	125	89	•	
SP 02	125	90	•	
NORDWEST	600	91	•	
KTM	CC	MY	A	P
WMX	125	88	•	•
WMX	250	88	•	•
MX	350	87 88	•	•

WMX	350	88	•	•
MX	500	87	•	•
WMX	500	88	•	•
BAJA	600	87	•	•
ER LCH	600	88	•	•

PASTIGLIE FRENO BRAKE PADS

► P.086

77.4
98.8

42.3
42.3

7.7
7.5

ORGANICA STRADALE
ROAD ORGANIC
P.086ASX

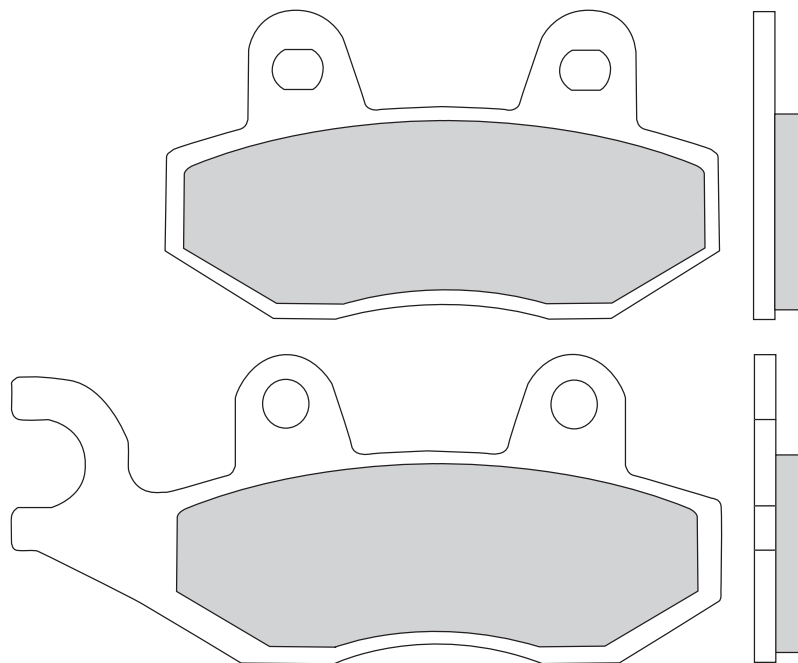

HUSQVARNA	CC	MY	A	P
CR	125	92 95	•	
CR	250	92 95	•	
WR	360	92 93	•	
TE	610	92 94	•	
KAWASAKI	CC	MY	A	P
KX G1/H1-H2/J1-J2	125	89 94	•	
KDX E5-E6	200	93 94	•	
KDX D1	250	91 93	•	
KLF C1-C9 BAYOU LEFT	300	89 99	•	
KX E1-E5	500	89 93	•	
KYMC0	CC	MY	A	P
YUP	50	01	•	
MOVIE	125	97	•	
VIVIO	125	01	•	
MOVIE	150	97	•	
VIVIO	150	99	•	
SUZUKI	CC	MY	A	P
RM H	125	87	•	
RM J	125	88	•	
RM K/L/M	125	89 91	•	
TS RK/RL/RM/RN/RP/RR	125	91 96	•	

UH BURGMAN	125	07		•
RM H	250	87		•
RM J/K/L/M	250	89 91		•
RM N/P	250	92 93		•
RM R/S	250	94 95		•
RMX K/L/M	250	89 91		•
RMX N/P	250	92 93		•
RMX R/S	250	94 95		•
DR SL-ST-SES-SEX	350	90 99		•
AN BURGMAN LEFT	400	07		•
LT F FW/FX/FY/FK1/FK2 P.SX	500	98 02		•
TRIUMPH	CC	MY	A	P
DAYTONA 675	675	06		•
AMERICA	800	03 06		•
BONNEVILLE	800	01 04		•
BONNEVILLE AMERICA	800	02		•
BONNEVILLE T100 CE	800	02 04		•
BONNEVILLE T100 P. SMITH	800	06		•
SPEEDMASTER	800	03 06		•
AMERICA	900	07		•
SCRAMBLER	900	06		•
SPEEDMASTER	900	07		•

THRUXTON	900	04		•
DAYTONA	955	99 00		•
DAYTONA I.E.	955	05		•
SPEED TRIPLE	955	99		•
SPRINT ST	955	99 04		•
SPEED TRIPLE T 509	995	99 04		•
SPEED TRIPLE	1050	05 07		•
SPRINT ST	1050	05		•
TROPHY	1200	93 03		•
YAMAHA	CC	MY	A	P
YZ A/B	125	90 92	•	
YZ B/D/E/F/G/H/J	125	93 97	•	
YZ W	125	89	•	
WR D/E/F	200	92 94	•	
TT RH/RL	250	96 99	•	
WR ZB/ZD/ZE	250	91 93	•	
WR ZF/ZG/ZH/ZJ	250	94 97	•	
YZ E/F/G/H/J 2T	250	93 97	•	
XTZ SUPER TENERE P. SX	750	89 95	•	

PASTIGLIE FRENO BRAKE PADS

► **P.087**



74.8



54.3



8.2

SINTERIZZATA
SINTERED
P.087ACX

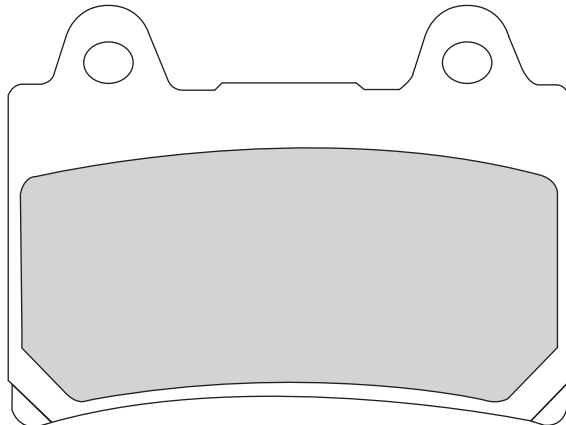

YAMAHA	CC	MY	A	P
TDR	250	88 92	•	
XS SE-C	250	80 81	•	
SRX (1JL)	400	87	•	

SRX (3SX)	600	90 91	•	
FZ	750	89 91	•	
TRX	850	96 98	•	
FJ	1200	88 95	•	

XJR	1200	95 98	•	
XVZ ROYAL STAR	1300	96 01	•	•
XV A WILD STAR	1600	99 04	•	
XV ROAD STAR WARRIOR	1700	02		

► **P.093**



75.0



36.0



10.0

ORGANICA STRADALE
ROAD ORGANIC
P.093ASX

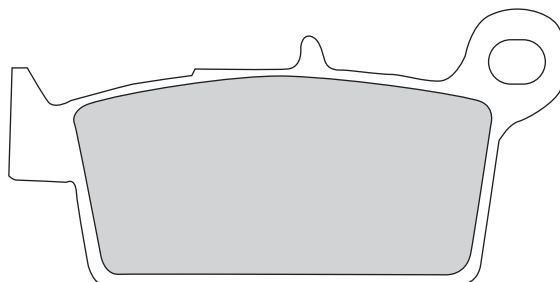

GAS GAS	CC	MY	A	P
EC (NISSIN)	125	00 07		•
MC	125	05		•
MX	125	01 04		•
PAMPERA	125	05		•
SM	125	02		•
EC (NISSIN)	200	00 07		•
EC (NISSIN)	250	00 07		•
MC	250	00		•
MX	250	01 04		•
SM	250	01		•
EC (NISSIN)	300	00 07		•
EC FSE	400	01		•
PAMPERA	400	06		•
SM FSE	400	01 02		•
FSE	450	05 06		•
FSR	450	07		•
FSE	500	05 06		•
FSR	515	08		•
HM	CC	MY	A	P
CRE	250	97 01		•
HONDA	CC	MY	A	P
CR RE-F-2F-G-2G-H-T	80	84 89		•
CR R	85	03		•
CR RH-J-K-L-M-N-P-R-S-T-X	125	94 00		•
CR RD-RK	250	87 89		•

CR RL-RM-RN-RP	250	90 93		•
CR RR-RX	250	94 01		•
XR RG-H-J-K-L-M-N-P-R-S	250	86 87		•
XR RT-RX	250	96 02		•
NX 4 FALCON	400	03		•
XR R	400	96 03		•
CR RE-RG-RH-RJ-RK	500	84 86		•
CR RL-RM-RN-RP-RR-RS-RT	500	94 00		•
XR RE-RH	600	91 93		•
XR RE-RH	600	94 99		•
XR RY/R1-R7	650	00 07		•
HUSQVARNA	CC	MY	A	P
WXE	125	07		•
KAWASAKI	CC	MY	A	P
KX K1-K5/L1-L4	125	95 03		•
KX M1-M2-M3	125	04		•
KLX H6	250	05		•
KLX J1-J6	250	98 03		•
KX K2-K5/L1-L5	250	95 02		•
KX M1-M2/R1	250	03		•
KX E8-E16	500	96 04		•
KYMGCO	CC	MY	A	P
COBRA CROSS	50	05		•
EASY	50	01		•
FEVER ZX	50	97		•
SCOUT	50	99		•

ZX	50	05		•
SUPER-9 L.C.	125	00		•
PEUGEOT	CC	MY	A	P
SV GEO	50	93		•
SV GEO	125	95		•
SUZUKI	CC	MY	A	P
RM K2/K3/K4/K5/K6/K7	125	02 07		•
RM T/V/W	125	96 98		•
RM X/Y/K1	125	99 01		•
RM T/V/W/X/Y/K1-K2	250	96 02		•
RMX ST/SV/SW/SX	250	96 99		•
SBK2	250	02		•
DR Z	400	00 07		•
DR Z SMK5/SMK6/SMK7	400	05 07		•
YAMAHA	CC	MY	A	P
YZ K/L/M/N/P	125	98 02		•
WR FN/FP/FR/FS/FT	250	00 02		•
WR ZK	250	98		•
YZ K/L/M 2T	250	98 03		•
WR FL/FM/FN	400	99 01		•
YZ FL	400	99		•
WR FN/FP	426	01 02		•
YZ FM	426	00		•
YZ FN/FP	426	01 02		•

PASTIGLIE FRENO BRAKE PADS

► P.095



69.9



54.4



8.5

SINTERIZZATA
SINTERED
P.095ACX

ORGANICA STRADALE
ROAD ORGANIC
P.095ASX

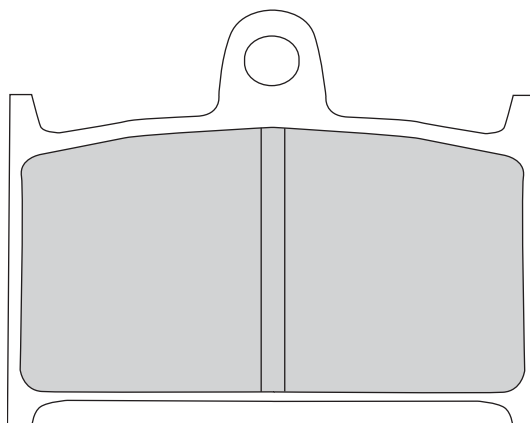

SUZUKI	CC	MY	A	P
RF RS/RS2/RT/RV/RW	900	95 99	•	
GSF BANDIT	1200	96 00	•	
TRIUMPH	CC	MY	A	P
DAYTONA	600	03 04	•	
SPEED FOUR	600	03	•	
TT	600	00 03	•	
DAYTONA	650	05	•	

DAYTONA SPORT	750	91	•	
DAYTONA	900	93	•	
DAYTONA T 595	900	97	•	
TRIDENT SPRINT	900	95	•	
DAYTONA	955	99 00	•	
DAYTONA	955	01 04	•	
DAYTONA I.E.	955	05	•	
SPEED TRIPLE	955	99	•	

SPRINT RS	955	00	•	
SPRINT ST	955	99 04	•	
SPEED TRIPLE T 509	995	99 04	•	
SPRINT ST	1050	05	•	
DAYTONA SPORT	1100	91	•	
TROPHY	1200	93 03	•	

► P.098



31.6



57.0



5.5

ORGANICA STRADALE
ROAD ORGANIC
P.098ASX

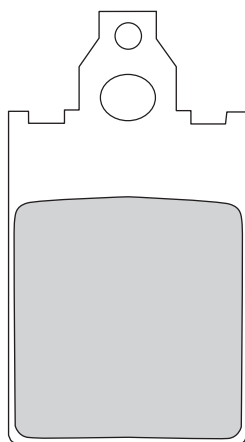

APRILIA	CC	MY	A	P
AF 1 AE	50	86	•	
AF 1 FUTURA	50	91	•	
ET AE	50	87	•	
EUROPA	50	91	•	
PEGASO	50	94	•	
RED ROSE	50	88 91	•	
RX	50	90 91	•	
TUAREG	50	86	•	
TUAREG	50	87 90	•	
TUAREG	50	91	•	
CLASSIC	80	93	•	
BETA	CC	MY	A	P
ALP	50	92 93	•	
CHRONO	50	94	•	

KR	50	87 88	•	
KR ADVENTURE	50	87	•	
MX	50	92	•	
RK 6	50	94 96	•	
TEMPO 13	50	94 97	•	
TR 34	125	88	•	
DERBI	CC	MY	A	P
GPR SPORT	50	96	•	
GPR	80	92	•	
FANTIC	CC	MY	A	P
OASIS RALLY	50	86	•	
GARELLI	CC	MY	A	P
SAHEL	80	89	•	
MALAGUTI	CC	MY	A	P
CENTRO SL	50	94	•	

F 12 PHANTHOM	50	98	•	
F 12 PHANTHOM	50	99	•	
F 15 FIREFOX L.C.	50	99	•	
PIAGGIO	CC	MY	A	P
FREE	50	96 00	•	
FREE	50	01	•	
TOMOS	CC	MY	A	P
REVIVAL	50	03	•	
STREETMATE	50	05	•	
TS	50	03	•	
YAMAHA	CC	MY	A	P
DT R	50	97 01	•	
DT R	50	02 04	•	

PASTIGLIE FRENO BRAKE PADS

► P.099



ORGANICA STRADALE
ROAD ORGANIC
P.099ASX

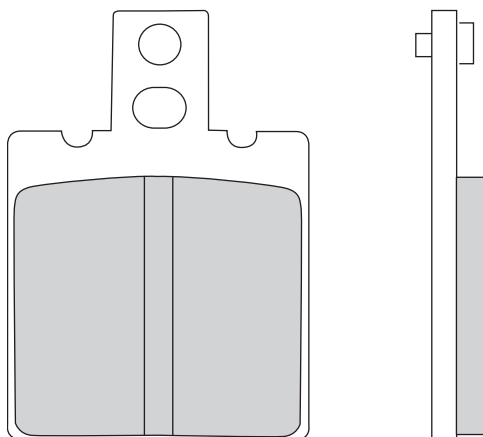

HONDA	CC	MY	A	P
CRM R	125	90 99		•
NSR-FM-FN	125	90		•

NSR-FM-FN	125	91	03	•
-----------	-----	----	----	---

► P.103

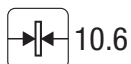

SINTERIZZATA
SINTERED
P.103ACX

ORGANICA STRADALE
ROAD ORGANIC
P.103ASX

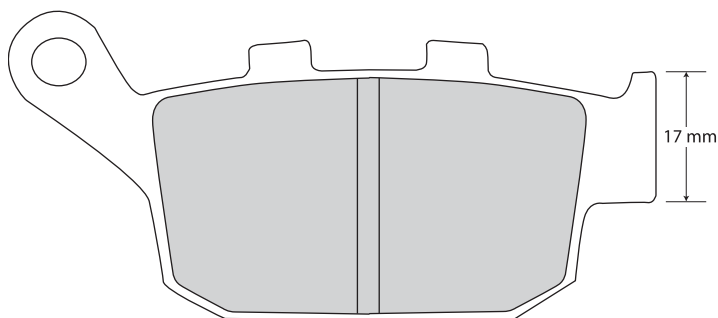

BUELL	CC	MY	A	P
BLAST	500	01		•
XB9R FIREBOLT	984	02		•
XB9S LIGHTNING	984	03		•
XB9SX CITY X	984	05		•
M2 CYCLONE	1200	98 02		•
S1 LIGHTNING	1200	98 02		•
S1 WHITELIGHTNING	1200	98 02		•
S3 THUNDERBOLD	1200	98 02		•
X1 LIGHTNING	1200	01 02		•
XB12R FIREBOLT	1200	04		•
XB12S LIGHTNING	1200	04		•
XB12SS LIGHTNING LONG	1200	06		•
XB12STT SUPER TT	1200	07		•

XB12X ULYSSES	1200	06		•
HONDA	CC	MY	A	P
PANTHEON	125	03		•
CB FT/FV/FX/FY "HORNET"	250	96 01		•
FORESIGHT	250	01		•
JAZZ	250	01		•
CB FOUR	400	97 00		•
CB SF "SUPERFOUR"	400	92 95		•
CBR R	400	87 89		•
CBR RR	400	90 94		•
CBR F	600	89 90		•
NTV REVERE-J-K	600	88 89		•
NTV-L-M-N	600	90 92		•
XL TRANSALP-VH-VV	600	97 00		•

NT DEAUVILLE	650	98 01		•
NTV REVERE-P-S-T-V	650	88 90		•
NX DOMINATOR-T-K-L-M-N	650	87		•
XL TRANSALP-VH-VV	650	00 05		•
XRV AFRICA TWIN	650	88 89		•
XRV-L V AFRICA TWIN	750	90 93		•
TRIUMPH	CC	MY	A	P
DAYTONA	600	03 04		•
SPEED FOUR	600	03		•
TT	600	00 03		•
DAYTONA	955	01 04		•

PASTIGLIE FRENO BRAKE PADS

► P.107



SINTERIZZATA
SINTERED
P.107ACX

ORGANICA STRADALE
ROAD ORGANIC
P.107ASX

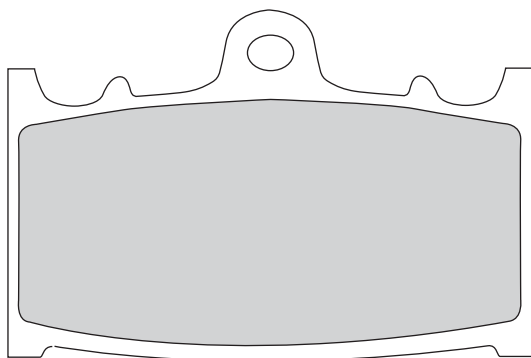

GAS GAS	CC	MY	A	P
SM	250	01	•	
KAWASAKI	CC	MY	A	P
KR C2-C3	250	90 92	•	
ZXR H1-H2	400	89	•	
ZXR R J1-J2	400	89 94	•	
ZZ-R	400	90 92	•	
ZZ-R	400	93 99	•	
ZX 6R	600	95 97	•	
ZZR	600	90 92	•	
ZZR	600	93 05	•	
ZXR HI-H2	750	89 90	•	
ZXR J1-J2/L1-L3/P1-P7	750	91 03	•	
ZXR R	750	91 94	•	
GPZ R A11	900	98	•	
GPZ R A7-A8	900	90 96	•	

ZX 9R B1-B2	900	94 95	•	
ZR A1-A2-A3-A4-B1	1100	93 95	•	
ZR ZEPHYR A1-A4	1100	92 95	•	
ZX D1-D5 ZX-11	1100	93 07	•	
ZZR	1100	90 92	•	
ZZR	1100	93 01	•	
ZZR C1H-C2H	1200	02 04	•	
VN A VULCAN	2000	04	•	
SUZUKI	CC	MY	A	P
RG FUN-FUP-FUR-FN GAMMA	125	92 96	•	
GSXR RK	250	89	•	
RGV J	250	88	•	
RGV K/L	250	89 90	•	
RGV M/N/P/R/S	250	91 95	•	
TV J/K/RK/L	250	88 90	•	
GSF K/NK/Z/NM/VZM/P/NP/VP	400	89 94	•	

GSF V/VS/V-V/VZ-V BANDIT	400	96 97	•	
GSR K6	400	06	•	
GSR	600	06	•	
GSX R V/W/X/Y	600	97 00	•	
GSX R K1-K2-K3	750	01 03	•	
GSX R Y/K1	750	00 01	•	
SV K3-K8/SK3-SK8	1000	03 08	•	
TL RW/RX/SX/RV/SY	1000	98 00	•	
TL SK1	1000	01 02	•	
TL SV/SW	1000	97 98	•	
GSF SAK6/AK6/GTSAK6	1200	06	•	
GSF AK7/ASK7 BANDIT	1250	07	•	
TL S	1600	97 00	•	

► P.108



SINTERIZZATA
SINTERED
P.108ACX

ORGANICA STRADALE
ROAD ORGANIC
P.108ASX

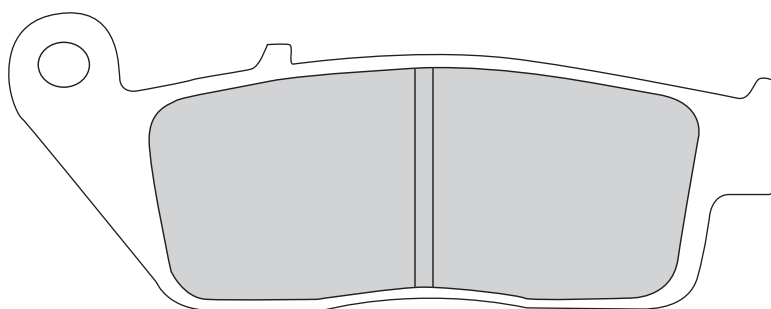

BUELL	CC	MY	A	P
BLAST	500	01	•	
CAGIVA	CC	MY	A	P
ELEFANT CATALITICA	900	93	•	
GRAN CANYON	900	99	•	
DAELIM	CC	MY	A	P
ROCKET	125	99	•	
S2	125	08	•	
S2	250	08	•	
HONDA	CC	MY	A	P
CB FOUR	400	97 00	•	
CB SF "SUPERFOUR"	400	92 95	•	
CBR R	400	87 89	•	
CBR RR	400	90 94	•	
VT SHADOW	400	97 01	•	
VT SHADOW SLASHER	400	02	•	

CB F HORNET	600	07 09	•	
CB F2Y/Y21/F22 S HORNET	600	00 05	•	
CB F7 HORNET	600	00 06	•	
CB FW/FX HORNET	600	98 99	•	
CB FY/F1-F6 HORNET	600	00 06	•	
CBF N4/NA4/S4/SA4/N5/NA5	600	04	•	
CBR F	600	95 98	•	
VT SHADOW-CN-CV	600	94 01	•	
NTV REVERE-P-S-T-V	650	88 90	•	
CB NIGHTHAWK	750	91 03	•	
CB SEVEN FIFTY	750	92 02	•	
PC "PACIFIC COAST"	750	89 97	•	
VF C MAGNA	750	93 99	•	
VFR F	750	88 97	•	
VFR-T-V	750	96 97	•	
VT SHADOW AERO C4	750	04	•	

VT SHADOW SPIRIT C2	750	07	•	
CBR FH-FJ-FK-FL-FV	1000	87 88	•	
ST L R-AN V PAN EUROPEAN	1100	90 95	•	
VT MAGNA	1200	95 99	•	
GL CV/CW/CX/CY/C1/C2	1500	97 03	•	
KAWASAKI	CC	MY	A	P
GPZ S	1100	95	•	
KYMCO	CC	MY	A	P
XCITING 250	250	05	•	
XCITING 500	500	05	•	
SUZUKI	CC	MY	A	P
GSF BANDIT	600	95 99	•	
AN BURGMAN	650	02	•	
AN BURGMAN EXECUTIVE	650	04 09	•	
VOXAN	CC	MY	A	P
SCRAMBLER	1000	01 03	•	

PASTIGLIE FRENO BRAKE PADS

► P.111



53.0



53.0



8.6

ORGANICA STRADALE
ROAD ORGANIC
P.111ASX

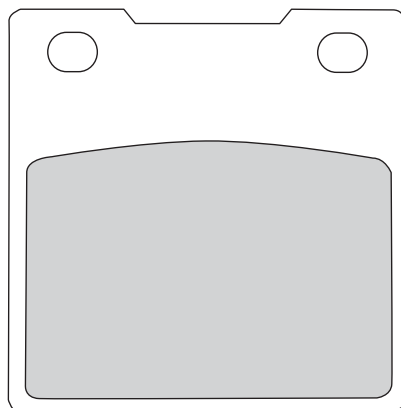

HYOSUNG	CC	MY	A	P
GT COMET	250	02		•
KAWASAKI	CC	MY	A	P
Z A3	250	81		•
GPZ S	1100	95		•
ZRX	1100	97	00	•
ZX D1-D5 ZX-11	1100	93	07	•
ZZR	1100	93	01	•
ZRX	1200	01	05	•
ZX 12R	1200	00	03	•
ZX 12R	1200	04	05	•
ZXR R	1200	01	05	•
ZZR C1H-C2H	1200	02	04	•
SUZUKI	CC	MY	A	P
GSF N/ZM/P/NP/ZP/R/NR	250	92	96	•
GSF VS/S BANDIT	250	97		•
GSX SSM KATANA	250	91		•
GSXR CJ/CK	250	88		•

GSXR RK	250	89		•
RGV J	250	88		•
TV J/K/RK/L	250	88	90	•
GSF K/NK/Z/VM/VZM/P/NP/VP	400	89	94	•
GSF M/N/P BANDIT	400	91	95	•
GSF V/V/S/V-V/VZ-V BANDIT	400	96	97	•
SV	400	99		•
GS ET/EV/EW/EX/EY/K1-K4	500	89	03	•
GS FK4/FK5/K5	500	04	05	•
GSF BANDIT	600	95	99	•
GSF BANDIT P.SX	600	00	04	•
GSX FJ/FK/FL/FM	600	88	91	•
GSX FN/FP/FR/FS/FT/FV	600	92	97	•
GSX FW/FX/FY/FK1-FK3	600	98	04	•
GSX R V/W/X/Y	600	97	00	•
SV X/SX/Y/SY/K1/SK1-SK2	650	99	02	•
GSX R F/G/XH	750	85	87	•
GSX R K1-K2-K3	750	01	03	•

GSX R WR/WS	750	94	95	•
GSX R Y/K1	750	00	01	•
GSX R-WT-W	750	96	99	•
GSX W/X/Y/K1 P.SX	750	98	03	•
RF RS/RS2/RT/RV/RW	900	95	99	•
TL RK1	1000	01	02	•
TL RW/RX/SX/RV/SY	1000	98	00	•
TL SK1	1000	01	02	•
TL SV/SW	1000	97	98	•
GSF BANDIT	1200	96	00	•
GSF BANDIT S	1200	01	05	•
GSX INAZUMA FSW/FSX	1200	98	99	•
GSX RK2/RZK3/RK4-RK5 /K6/K7	1300	02	07	•
GSX RX/RV/RK1 HAYABUSA	1300	99	01	•
TL S	1600	97	00	•

► P.114



62.0



40.6



9.5

ORGANICA STRADALE
ROAD ORGANIC
P.114ASX

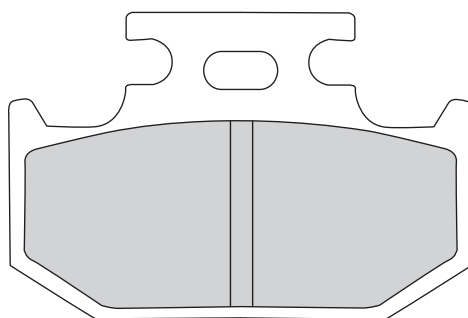

KAWASAKI	CC	MY	A	P
KDX A1-A2-B1-B2	125	91	94	•
KX G1/H1-H2/J1-J2	125	89	94	•
KDX E1-E2-E3-E4	200	89	92	•
KDX E5-E6	200	93	94	•
KDX H1-H5	200	95	99	•
KDX R A1-A12	220	97	05	•
KDX D1	250	91	93	•
KLX D1-D2	250	93	95	•
KLX G1	250	94	99	•
KX K1	250	94		•
KX E1-E5	500	89	93	•

KX E6-E7	500	94	95	•
KLX C1-C3	650	93	97	•
SUZUKI	CC	MY	A	P
RM K/L/M	125	89	91	•
DR R	250	95	00	•
DR R DEJBEL	250	96	98	•
DR Z K1-K5	250	01	05	•
RM J/K/L/M	250	89	91	•
RM N/P	250	92	93	•
RM R/S	250	94	95	•
RMX K/L/M	250	89	91	•
RMX N/P	250	92	93	•

RMX R/S	250	94	95	•
RMX T/V/W	250	96	98	•
DR SL-ST-SES-SEX	350	90	99	•
DR SET	650	96		•
YAMAHA	CC	MY	A	P
DT RE	125	05	07	•
DT X	125	05		•
YZ A/B	125	90	92	•
YZ B/D/E/F/G/H/J	125	93	97	•
WR D/E/F	200	92	94	•
TT RH/RL	250	96	99	•
WR ZB/ZD/ZE	250	91	93	•

PASTIGLIE FRENO BRAKE PADS

► P.114

YAMAHA	CC	MY	A	P
WR ZF/ZG/ZH/ZJ	250	94 97		•

YZ E/F/G/H/J 2T	250	93 97		•
YZ W/WRW	250	89 92		•
WR FK	400	98		•
YZ FK	400	98		•

TT E/R/S	600	93 02		•
TT RES	600	03 04		•

► P.116



77.4
98.8



42.3
42.4

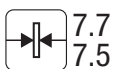

7.7
7.5

SINTERIZZATA
SINTERED
P.116ACX

ORGANICA STRADALE
ROAD ORGANIC
P.116ASX

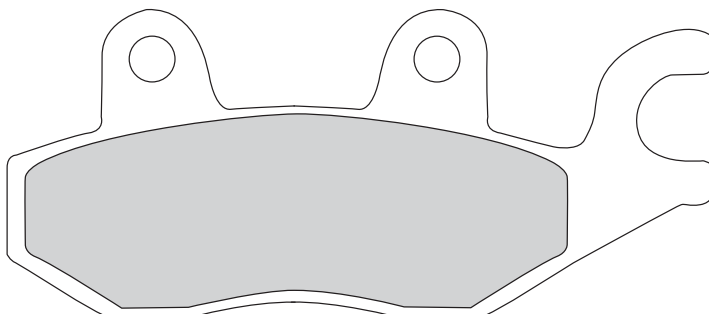
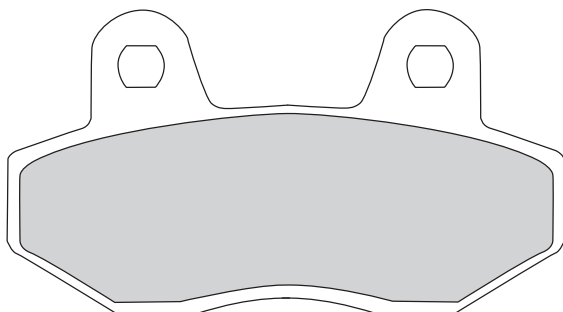

CAGIVA	CC	MY	A	P
CANYON	500	96 00		•
CANYON	600	96 99		•
CANYON	900	97		•
ELEFANT	900	90		•
ELEFANT I.E.	900	91		•
GRAN CANYON	900	99		•
ELEFANT	906	89		•

NAVIGATOR	1000	00 05		•
KAWASAKI	CC	MY	A	P
BN ELIMINATOR A3	125	00		•
KLF C1-C9 BAYOU RIGHT	300	89 99		•
KLF B1-B7 BAYOU RIGHT	400	93 99		•
SUZUKI	CC	MY	A	P
LT F FW/FX/FY/FK1/FK2 P.SX	500	98 02		•
DR SM	800	91		•

TRIUMPH	CC	MY	A	P
DAYTONA SPORT	750	91		•
TIGER	955	05		•
TIGER 1050	1050	07		•
YAMAHA	CC	MY	A	P
CYGNUS X	125	03		•
XTZ SUPER TENERE P. SX	750	89 95		•

PASTIGLIE FRENO BRAKE PADS

► P.129



SINTERIZZATA
SINTERED
P.129ACX

ORGANICA STRADALE
ROAD ORGANIC
P.129ASX

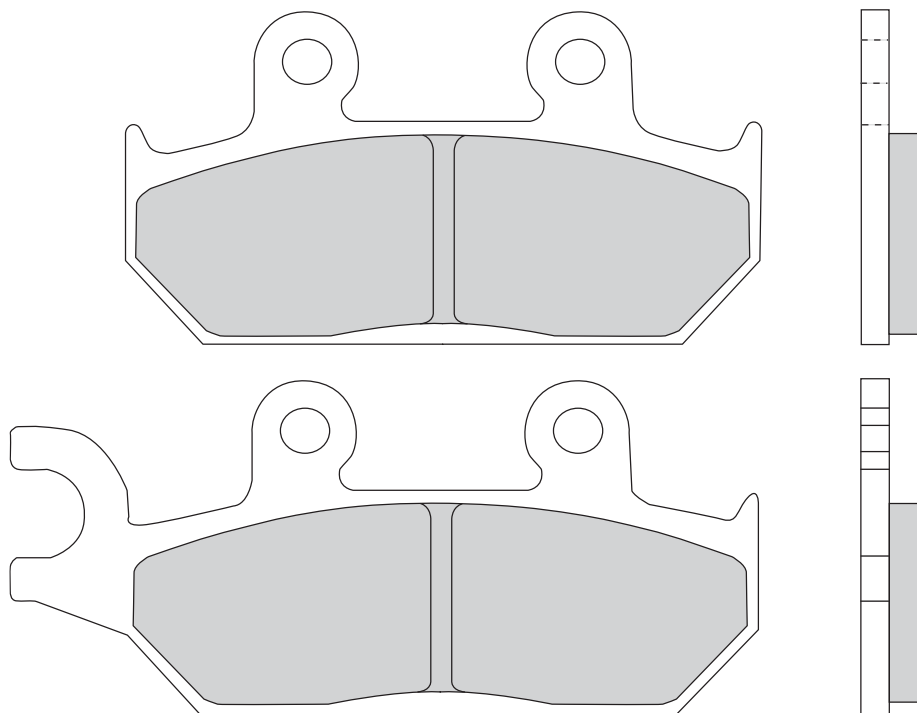

YAMAHA	CC	MY	A	P
XT E/ZE	600	90 03	•	
XTZ TENERE	660	91 98	•	

► P.133



ORGANICA STRADALE
ROAD ORGANIC
P.133ASX

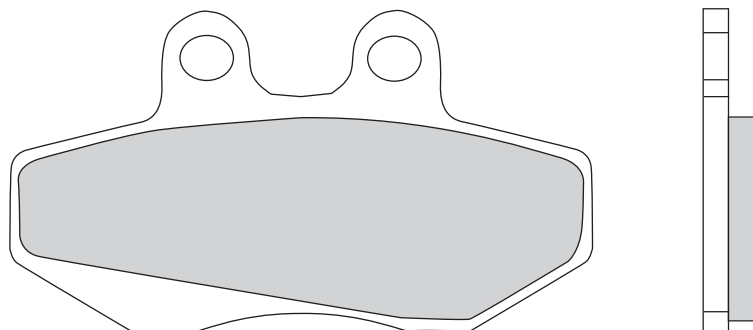

APRILIA	CC	MY	A	P
RX	50	92 97	•	
PEGASO	125	91	•	
RED ROSE AE	125	91	•	
RX	125	92 93	•	
TUAREG RALLY	125	91	•	
PEGASO AE	600	91	•	
BETA	CC	MY	A	P
RK 6	50	94 96	•	
RK 6 ENDURO	50	97 02	•	
RR ENDURO ALU	50	04 07	•	
RR MOTARD ALU	50	04 07	•	
CAGIVA	CC	MY	A	P
ELEFANT BIFARO	750	90 93		•
ELEFANT	900	91		•
DERBI	CC	MY	A	P
GPR R	50	97	•	

SENDA R DRD	50	02	•	
ATMOSPHERE	125	99	•	
PREDATOR	125	99	•	
PREDATOR	180	99	•	
GAS GAS	CC	MY	A	P
EC ROOKIE	50	01 04	•	
SM ROOKIE	50	01 04	•	
GILERA	CC	MY	A	P
GPR POGGIALI REPLICA	50	03	•	
RUNNER FX	200	97 98	•	
HUSQVARNA	CC	MY	A	P
SM	50	02	•	
WR	50	02	•	
WXE	125	07	•	
HYOSUNG	CC	MY	A	P
GT COMET	250	03	•	•
GT R	250	07	•	•

GT	650	04	•	•
GT CUSTOM TRENDKILLER	650	07	•	•
GT R	650	05	•	•
GT S	650	05	•	•
GT TTC	650	07	•	•
GT X	650	07	•	•
GV AGUILA	650	06	•	•
ITALJET	CC	MY	A	P
BAZOOKA	650	06	•	•
GRIFON	650	06	•	•
KTM	CC	MY	A	P
EXC	50	99	•	
MOTORHISPANIA	CC	MY	A	P
RX RACING	50	00 03	•	
RYZ SUPERMOTARD	50	04 05	•	
PEUGEOT	CC	MY	A	P
XR 6	50	05	•	

P.133

RIEJU	CC	MY	A	P
MRX PRO	50	05	•	

RACING SPECIAL EDITION	50	01	•	
SMX	50	02	•	
SPIKE RACING	50	02	•	
MRX	125	03	•	

SMX	125	03	•	
-----	-----	----	---	--

P.134



86.0



36.7



9.0

SINTERIZZATA
SINTERED
P.134ACX

ORGANICA STRADALE
ROAD ORGANIC
P.134ASX

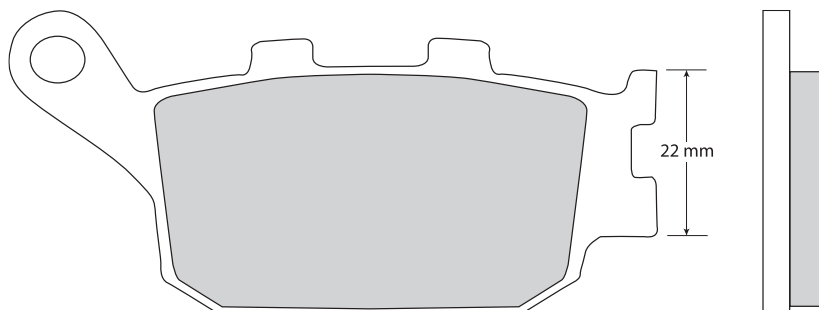

HONDA	CC	MY	A	P
PANTHEON	150	03		•
VTR	250	98		•
CB SBS	400	05		•
CBF 4	500	05		•
CBF A4/A5	500	04		•
CBF A4/A5/A6 ABS	500	04		•
CB AF7 HORNET ABS	600	07		•
CB F2Y/Y21/F22 S HORNET	600	00	05	•
CB FW/FX HORNET	600	98	99	•
CB FY/F1-F6 HORNET	600	00	06	•
CBF N4/NA4/S4/SA4/N5/NA5	600	04		•
CBR F	600	91	94	•
CBR F	600	95	98	•
CBR F	600	99	01	•
CBR F4 SPORT	600	02	03	•
CBR RR	600	03	04	•
CBR RR	600	05	06	•
CB NIGHTHAWK	750	91	03	•
CB SEVEN FIFTY	750	92	02	•

CB F2/F3/F4/F5 HORNET	900	01	05	•
CBR RR	900	92	95	•
CBR RR	900	98	99	•
CBR RR	900	96	97	•
CBR RR	929	00	01	•
CBR RR	954	02	03	•
CB FR-FT	1000	93	97	•
CBR RR	1000	04	05	•
VTR F FIRESTORM	1000	97	05	•
VTR SP 1	1000	00	01	•
VTR SP 2	1000	02	05	•
VT C4 SHADOW SABRE	1100	04		•
CB A5	1300	04		•
CB F3/F13	1300	03		•
CB SS	1300	04		•
VTX	1300	03		•
KAWASAKI	CC	MY	A	P
Z R	750	11		•
PEUGEOT	CC	MY	A	P
SV	250	03		•

SUZUKI	CC	MY	A	P
DL V-STROM LEFT	650	04		•
GSF BANDIT / S BANDIT RIGHT	650	05		•
SV K3/SK3 P.SX	650	03	05	•
SV SK3-SK7 PINZA SX	650	03	07	•
XF V/W/X/Y FREEWIND	650	97	02	•
DL K2-K7 V-STORM P. SX	1000	02	07	•
SV K3-K8/SK3-SK8	1000	03	08	•
GSF SAK6/AK6/GTSAK6	1200	06		•
GSF AK7/ASK7 BANDIT	1250	07		•
B-KING	1300	07		•
YAMAHA	CC	MY	A	P
FZ 6 FAZER	600	04	05	•
YZF R6 S	600	07		•
FZ1	1000	06		•
YZF R1	1000	04	06	•
YZF R1	1000	07		•

P.139



39.7



49.5



6.5

SINTERIZZATA
SINTERED
P.139ACX

ORGANICA STRADALE
ROAD ORGANIC
P.139ASX

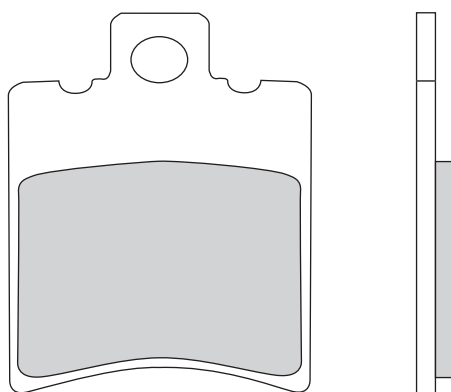

APRILIA	CC	MY	A	P
AMICO SPORT LX	50	92		•
AREA 51	50	98	99	•
AREA 51 SBK	50	00	02	•

GULLIVER	50	95	00	•
GULLIVER L.C.	50	96	00	•
HABANA	50	98	05	•
MOJITO	50	99	05	•

RALLY	50	94	00	•
RALLY L.C.	50	97		•
SCARABEO	50	96	97	•
SCARABEO	50	98	02	•

PASTIGLIE FRENO BRAKE PADS

► P.139

APRILIA	CC	MY	A	P
SCARABEO D-TECH	50	02 06	•	•
SCARABEO DE LUXE	50	98 01	•	•
SCARABEO STREET	50	07	•	•
SONIC-SONIC G.P.	50	98	•	•
SR D-TECH	50	01	•	•
SR R	50	05	•	•
SR STEALTH L.C.	50	97	•	•
SR STREET	50	07	•	•
SR WWW	50	97	•	•
SCARABEO	100	03 07	•	•
LEONARDO	125	96 98	•	•
LEONARDO 4T	150	98	•	•
SR	150	00	•	•
RS	250	95 97	•	•
RS	250	98	•	•
BENELLI	CC	MY	A	P
491 GT	50	98	•	•
491 NAKED	50	98	•	•
491 SPORT	50	98	•	•
491 SUPERBIKE-491 R	50	98	•	•
K 2	50	98	•	•
K 2 LIQUIDO	50	98	•	•
K 2 NAMUR	50	98	•	•
PEPE	50	99	•	•
K 2	100	99	•	•
ADIVA	125	00	•	•
ADIVA	125	01 04	•	•
VELVET	125	99 07	•	•
ADIVA	150	00	•	•
VELVET	150	99 07	•	•
BETA	CC	MY	A	P
ARK	50	96	•	•
ARK L.C.	50	97	•	•
QUADRA	50	97 01	•	•
TEMPO	50	98 02	•	•
CAGIVA	CC	MY	A	P
MANTIS	50	99	•	•
NUVOLA	50	00	•	•

CPI	CC	MY	A	P
GTR	50	03	•	•
GTR/GTS	125	02	•	•
GTR/GTS	200	02	•	•
GILERA	CC	MY	A	P
EASY MOVING	50	96	•	•
ICE	50	01	•	•
NRG	50	93	•	•
NRG	50	96	•	•
NRG-MC2	50	99 00	•	•
NRG-MC3	50	01	•	•
NTT	50	94	•	•
NTT	50	96	•	•
RUNNER DD	50	97	•	•
STALKER DD	50	99	•	•
STALKER DT	50	99	•	•
STORM	50	94	•	•
RUNNER SP	125	01	•	•
TYPHOON	125	96	•	•
HONDA	CC	MY	A	P
SFX	50	95	•	•
SH FIFTY	50	00	•	•
SH SCOOPY	50	96	•	•
SKY	50	97	•	•
X 8 R	50	98	•	•
ITALJET	CC	MY	A	P
FORMULA	50	94 99	•	•
FORMULA L.C.	50	00	•	•
MALAGUTI	CC	MY	A	P
CIAK	50	99	•	•
F 10	50	96	•	•
F 12 PHANTHOM	50	99	•	•
YESTERDAY	50	98	•	•
CIAK	100	00	•	•
F 12 PHANTHOM	100	00	•	•
CIAK	125	03	•	•
CIAK	150	03	•	•
MBK	CC	MY	A	P
FLIPPER	50	99	•	•
STUNT	50	00	•	•
BOOSTER	100	99	•	•

OVETTO	100	00	•	•
MOTRON	CC	MY	A	P
SPIKE	50	98	•	•
SYNCRO	50	98	•	•
THUNDER SC	50	95	•	•
PEUGEOT	CC	MY	A	P
BUXY RS	50	94	•	•
SPEEDAKE	50	95	•	•
ZENITH LUXE	80	96	•	•
PIAGGIO	CC	MY	A	P
FREE	50	02	•	•
NRG EXTREME ACQUA	50	96 00	•	•
NRG EXTREME ARIA	50	96 00	•	•
NRG=MC2	50	99	•	•
NTT	50	95	•	•
TYPHOON	50	94 97	•	•
TYPHOON	50	01 03	•	•
TYPHOON X	50	98 00	•	•
ZIP FAST RIDER	50	93	•	•
FREE	100	02	•	•
HEXAGON	125	94 97	•	•
TYPHOON	125	96 98	•	•
TYPHOON X	125	99 03	•	•
SUZUKI	CC	MY	A	P
ADRESS	50	95	•	•
KATANA	50	97	•	•
KATANA DD	50	99	•	•
UF ESTILETE	50	00	•	•
YAMAHA	CC	MY	A	P
BREEZE	50	95	•	•
BW'S N.G.	50	96	•	•
BW'S SPY	50	96	•	•
CW ZUMA II	50	00 01	•	•
SPY	50	95	•	•
WHY	50	98	•	•
BW'S	100	00	•	•
TEO'S	125	01	•	•
TEO'S	150	01	•	•

► P.141



ORGANICA STRADALE
ROAD ORGANIC
P.141ASX

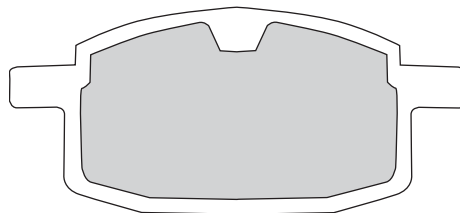

ADLY	CC	MY	A	P
CAT	50	01	•	•
COSY	50	01	•	•
FOX	50	07	•	•
FOX PLUS	50	01	•	•
JET	50	96	•	•
FANTIC	CC	MY	A	P
BIG WHEELS	50	91	•	•
GRINTA	50	97	•	•
PONY SR	50	92	•	•
QUEENIE	50	95	•	•

ITALJET	CC	MY	A	P
BAZOOKA 2	50	92 97	•	•
CRUISE	50	95	•	•
PISTA	50	92	•	•
YANKEE 8	50	94	•	•
MBK	CC	MY	A	P
TARGET	50	92 94	•	•
BOOSTER	100	00	•	•
PGO	CC	MY	A	P
BIG MAX	50	95	•	•
HOT	50	98	•	•

MEGA FIFTY	50	99	•	•
PMX	50	99	•	•
TORNADO	50	96	•	•
BIG MAX	80	95	•	•
TORNADO	125	96	•	•
YAMAHA	CC	MY	A	P
AXIS	50	94	•	•
CRZ	50	92	•	•
CW T ZUMA	50	02 05	•	•

PASTIGLIE FRENO BRAKE PADS

► P.143



SINTERIZZATA
SINTERED
P.143ACX

ORGANICA STRADALE
ROAD ORGANIC
P.143ASX

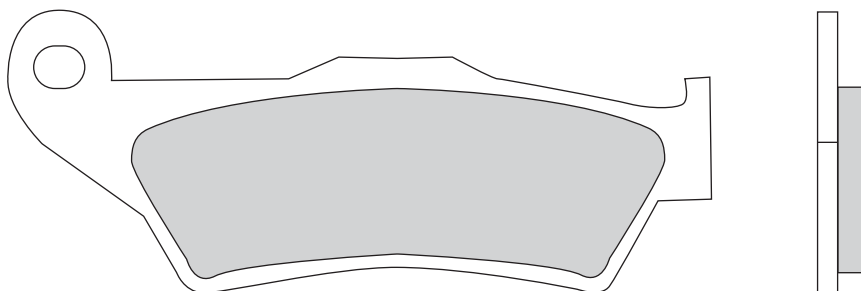

ALFER	CC	MY	A	P
VRE 4-STROKE	125	00	•	
AR	250	93	•	
NO LIMITS	250	95	•	
VR	250	94	•	
VR ENDURO	250	95	•	
VR MOTOCROSS	250	95	•	
VR SUPERMOTARD	250	99	•	
APRILIA	CC	MY	A	P
MX	125	04	•	
RX	125	00 01	•	
PEGASO	650	96	•	
RST FUTURA	1000	01 04	•	
BENELLI	CC	MY	A	P
BX	450	07	•	
BMW	CC	MY	A	P
G 450 ENDURO	450	08	•	
CAGIVA	CC	MY	A	P
ELEFANT	750	94	•	
DUCATI	CC	MY	A	P
M620	618	05	•	
M620 DARK	618	05	•	
DIAVEL	1200	11	•	
GAS GAS	CC	MY	A	P
EC (BREMBO)	125	97 99	•	
EC (BREMBO)	200	97 99	•	
CROSS	250	95	•	
EC (BREMBO)	250	97 99	•	
FSE 4T	250	99	•	
MC	250	99	•	
TT	250	95	•	
EC (BREMBO)	300	97 99	•	
FSE 4T	400	99	•	
PAMPERA	400	06	•	
GILERA	CC	MY	A	P
NEXUS	500	04	•	
GP	800	07	•	
HM	CC	MY	A	P
CRE BAJA	50	01 02	•	
DERAPAGE	50	01 02	•	
HUSABERG	CC	MY	A	P
SM S	125	00	•	
FC	350	95	•	
FE	350	95	•	
FC	400	99 02	•	
FE	400	00	•	
FC	450	98 03	•	
FE E	450	04 08	•	
FX	450	03 09	•	
FC	470	01	•	
FX E	470	01	•	
CROSS	500	93	•	

FC	501	95	•	
FE	501	95	•	
FC	550	01	•	
FE E	550	04	•	
FC	600	95	•	
FE	600	95	•	
FE E	650	01	•	
FS	650	01	•	
FX E	650	01	•	
HUSQVARNA	CC	MY	A	P
CR	125	96 04	•	
CR	125	05	•	
SM S	125	02	•	
WR	125	95 05	•	
WR	125	06	•	
WRE	125	94 00	•	
WRE	125	01	•	
CR	250	96 04	•	
CR	250	05	•	
TC	250	02 03	•	
TC	250	04	•	
TE	250	02 05	•	
TE	250	06	•	
WR	250	93 05	•	
WR	250	06	•	
TE	350	95 97	•	
CR	360	94	•	
WR	360	94	•	
TE	400	02	•	
TE	410	94 05	•	
TE	410	06	•	
TE E	410	01	•	
TC	450	03 04	•	
TC	450	05	•	
TE	450	03 04	•	
TE	450	05	•	
TC	510	04	•	
TC	510	05	•	
TE	510	04	•	
TE	510	05	•	
TE	510	06	•	
TC	570	01	•	
TE	570	01 04	•	
TC	610	95	•	
TE	610	95 99	•	
TE E	610	00 03	•	
TE E	610	04	•	
KTM	CC	MY	A	P
ENDURO	125	93	•	
EXC	125	03	•	
EXC	125	04 06	•	
EXC	125	07	•	

EXC-EGS-SX	125	95 97	•	
EXC-EGS-SX	125	98 03	•	
EXE	125	00	•	
GS	125	93	•	
GS	125	94 97	•	
LC 2	125	98 00	•	
MX	125	92	•	
MX SUPERMOTO	125	00	•	
SX	125	93	•	
SX	125	94 97	•	
SX	125	04	•	
SX	125	98 03	•	
EGS	200	99 02	•	
EXC	200	98 02	•	
EXC	200	03	•	
EXC	200	04 06	•	
EXC	200	07	•	
SX	200	03	•	
SX	200	04	•	
ENDURO	250	93	•	
EXC	250	03	•	
EXC-EGS-SX	250	93 95	•	
EXC-EGS-SX	250	96 02	•	
GS	250	93	•	
GS	250	94	•	
MX	250	89	•	
MX	250	90 02	•	
MX	250	03	•	
SX	250	03	•	
SX-EGS-EXC	250	93 95	•	
SX-EGS-EXC	250	96 02	•	
SX-F	250	05 08	•	
XC-F	250	06 08	•	
XC-F-W	250	06 08	•	
ENDURO	300	93	•	
EXC	300	03	•	
SX-EGS-EXC	300	93	•	
LC 4 EXC	350	94	•	
MX	350	92	•	
EXC RACING	400	04 05	•	
EXC RACING	400	06	•	
LC 4 EGS	400	94	•	
EXC RACING	450	03	•	
EXC RACING	450	04 05	•	
EXC RACING	450	06	•	
SX	450	94 02	•	
SX RACING	450	03	•	
SX RACING	450	04 05	•	
SX RACING	450	06	•	
MX	500	92	•	
SX	500	93	•	
EXC RACING	525	03	•	

► P.143

KTM	CC	MY	A	P
EXC RACING	525	04 05	•	
EXC RACING	525	06	•	
SX RACING	525	03	•	
SX RACING	525	04 05	•	
SX RACING	525	06	•	
SXC	540	99	•	
MG-SX	550	94	•	
4T GS	600	93	•	
4T GS	600	94	•	
DUKE II	620	99 02	•	
LC 4 EXC-EGS-SX	620	94 02	•	
LC4 SXC SUPERMOTO	620	98 02	•	
SC	620	99	•	
EXC	625	03	•	
LC4 SUPERCOMPETITION	625	02	•	
LC 4 ADVENTURE R	640	98	•	
LC 4 ENDURO	640	99	•	
LC 4 SUPERMOTO	640	99 02	•	
LC 4 SMC SUPERMOTO	660	03	•	
ADVENTURE S	950	03	•	
ADVENTURE S	950	04 06	•	
SM	950	05 07	•	
SM R	950	05 07	•	
SMC	950	05	•	
ADVENTURE S	990	06	•	
MAICO	CC	MY	A	P
ENDURO	250	99	•	
MOTOCROSS	250	99	•	
ENDURO	500	99	•	

MOTOCROSS	500	99	•	
SUPERMOTARD	500	99	•	
MBK	CC	MY	A	P
SKYLINER	125	99	•	
SKYLINER	125	02	•	
THUNDER	125	02	•	
DOODO	150	00	•	
SKYLINER	150	00	•	
THUNDER	150	01	•	
SKYLINER	180	03	•	
KILIBRE	300	03	•	•
MOTO GUZZI	CC	MY	A	P
CALIFORNIA EV	1100	99	•	
CALIFORNIA JACKAL	1100	99	•	
CALIFORNIA SPECIAL	1100	99	•	
MOTO TM	CC	MY	A	P
GS-MC	80	93	•	
MX	85	05	•	
CROSS	125	00	•	
ENDURO	125	00 03	•	
ENDURO	125	04	•	
GS-MC	125	93	•	
MX	125	05	•	
ENDURO 4T	250	00 03	•	
ENDURO 4T	250	04	•	
CROSS 4T	400	00	•	
EN F ES	450	05	•	
MX F	450	05	•	
EN F ES	530	05	•	
MX F	530	05	•	
PIAGGIO	CC	MY	A	P
BEVERLY I.E.	400	07	•	

X 9 EVOLUTION ABS	500	03 06	•	
X 9 I.E.	500	07	•	
SHERCO	CC	MY	A	P
4.5 ENDURO/SUPERMOTARD	450	04 05	•	
5.1 ENDURO	510	06	•	
SUZUKI	CC	MY	A	P
UH BURGMAN	125	02 06	•	
UH BURGMAN	150	03	•	
VERTEMATI	CC	MY	A	P
492 ENDURO	500	99	•	
495 CROSS	500	99	•	
C	500	01	•	
VOR	CC	MY	A	P
MX	350	01	•	
ENDURO	400	00	•	
492 ENDURO	500	99	•	
495 CROSS	500	99	•	
ENDURO	530	01	•	
YAMAHA	CC	MY	A	P
MAJESTY SP	125	98 00	•	
MAJESTY SP	125	01	•	
MAXSTER	125	01	•	
MAJESTY 4T	150	99	•	
MAXSTER	150	01	•	
MAJESTY SP	180	03	•	
VERSITY	300	03	•	•
TT E/R/S	600	93 02	•	
TT RES	600	03 04	•	

► P.144



31.8



51.2



5.5

ORGANICA STRADALE
ROAD ORGANIC
P.144ASX

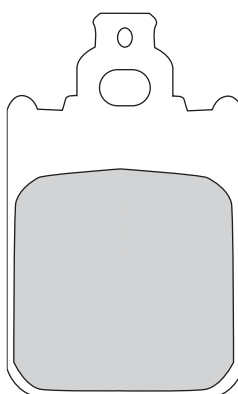

CAGIVA	CC	MY	A	P
PRIMA	50	92 94	•	
MALAGUTI	CC	MY	A	P
F 15 FIREFOX L.C.	50	99	•	
PIAGGIO	CC	MY	A	P
QUARTZ	50	91 95	•	
SKIPPER	125	93	•	
VESPA	CC	MY	A	P
VESPA PX	125	98	•	
VESPA PX	200	98	•	

PASTIGLIE FRENO BRAKE PADS

► P.150



SINTERIZZATA
SINTERED
P.150ACX

ORGANICA STRADALE
ROAD ORGANIC
P.150ASX

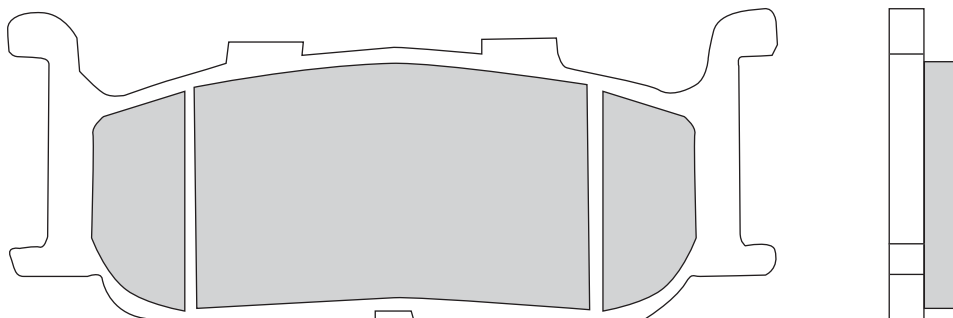

MBK	CC	MY	A	P
SKYLINER	400	04	•	
YAMAHA	CC	MY	A	P
TDR R	125	93 03	•	
MORPHOUS	250	05	•	
MAJESTY S / T	400	04	•	

XVS	400	96 99	•	
T MAX	500	01 03	•	
XV S VIRAGO	535	95 03	•	
XJ N	600	95 97	•	
XJ S DIVERSION	600	92 97	•	
XVS DRAG STAR	650	97 04	•	

XV VIRAGO	750	92 97	•	
XJ S DIVERSION	900	95 03	•	
XV VIRAGO	1100	94 98	•	
XVS A DRAG STAR CLASSIC	1100	00 05	•	
XV A WILD STAR	1600	99 04	•	

► P.156



SINTERIZZATA
SINTERED
P.156ACX

ORGANICA STRADALE
ROAD ORGANIC
P.156ASX

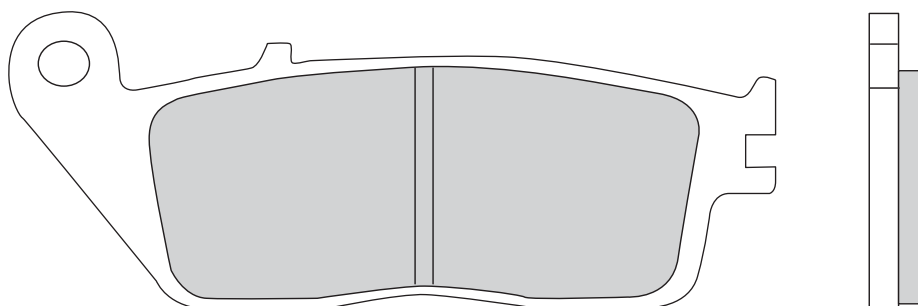

CAGIVA	CC	MY	A	P
NAVIGATOR	1000	00 05	•	
HONDA	CC	MY	A	P
CB-N-T	250	92 99	•	
VTR	250	98	•	

NTV REVERE-P-S-T-V	650	88 90	•	
VT MAGNA	1200	95 99	•	
KYMC0	CC	MY	A	P
XCITING	300	08	•	•

TRIUMPH	CC	MY	A	P
THRUXTON	900	04	•	
TIGER	955	01 04	•	

PASTIGLIE FRENO BRAKE PADS

► P.158

94.5
76.8

42.0
41.8

7.5
7.5

SINTERIZZATA
SINTERED
P.158ACX

ORGANICA STRADALE
ROAD ORGANIC
P.158ASX

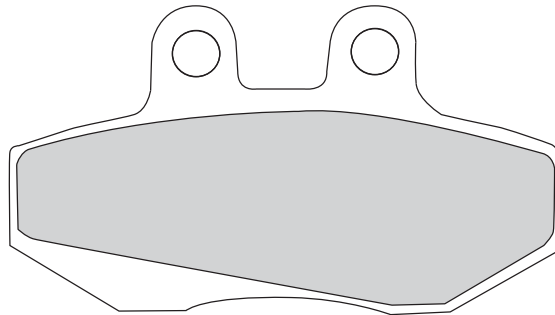
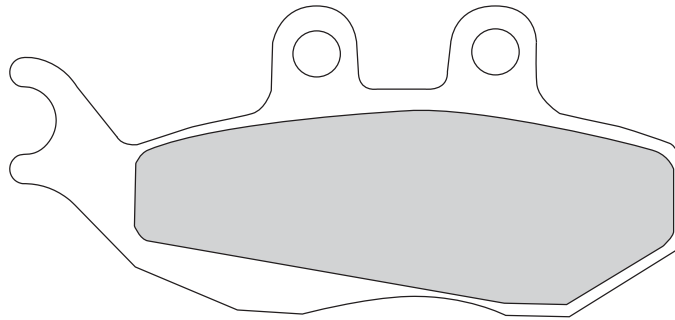

APRILIA	CC	MY	A	P
CLASSIC	50	96	•	
MX SUPERMOTARD	50	02	•	
RS	50	00 06	•	
RS REPLICCA	50	99	•	
RX	50	98	•	
RX C-CD	50	93	•	
RX RACING	50	04 06	•	
TUONO	50	04	•	
RX	125	94 99	•	
BENELLI	CC	MY	A	P
VELVET	250	98 00	•	
VELVET	250	01 07	•	
VELVET DUSK	400	03	•	
BETA	CC	MY	A	P
ALP	125	05	•	
RR	125	06	•	
ALP	200	05	•	
ALP 4.0	400	04	•	
CPI	CC	MY	A	P
GTR/GTS	125	02	•	
OLIVER SPORT	150	08	•	
GTR/GTS	180	08	•	
GTR/GTS	200	02	•	
DERBI	CC	MY	A	P
BLACK DEVIL	50	04	•	
SENDA SM DRD	50	02	•	
SENDA SM DRD	50	03	•	
SENDA 4T	125	04	•	
SENDA X - TREM SM	125	04	•	
FANTIC	CC	MY	A	P
CABALLERO RC	50	94	•	
GAS GAS	CC	MY	A	P
SM	50	05	•	
PAMPERA	125	03 04	•	

PAMPERA	125	05	•	
PAMPERA	250	03	•	
PAMPERA	280	04	•	
GILERA	CC	MY	A	P
DNA L.C. (G)	50	00 02	•	
DNA 4T (G)	125	01 02	•	
RUNNER FX (G)	125	97 99	•	
RUNNER FX (G)	125	00	•	
RUNNER SP	125	98 00	•	
RUNNER SP	125	01	•	
RUNNER VX (G)	125	01	•	
DNA 4T (G)	180	01	•	
RUNNER FXR (G)	180	00	•	
RUNNER FXR SP (G)	180	99	•	
RUNNER FXR SP (H)	180	99	•	
RUNNER VXR 4T (G)	180	01	•	
RUNNER VXR 4T (H)	180	01	•	
RUNNER SP	200	99	•	
HM	CC	MY	A	P
CRE BAJA	50	03 09	•	
CRE ENDURO	50	99	•	
DERAPAGE	50	03 06	•	
SIX	50	03 06	•	
MALAGUTI	CC	MY	A	P
XSM SUPERMOTARD	50	03	•	
F 12 PHANTHOM MAX	125	04	•	
MADISON	125	99	•	
MADISON	150	99	•	
MADISON	180	01	•	
MADISON S	200	04	•	
PASSWORD	250	05	•	
PEUGEOT	CC	MY	A	P
XP S6 SUPERMOTARD	50	04	•	
ELISEO	125	98 01	•	
ELISEO	125	03	•	

ELISTAR	125	02 03	•	
JET FORCE	125	03	•	
SATELIS K15	125	06	•	
ELISEO	150	98 01	•	
ELISEO	150	03	•	
ELISTAR	150	02 03	•	
PGO	CC	MY	A	P
RODOSHOW	50	01	•	
PIAGGIO	CC	MY	A	P
BEVERLY B 4T (G)	125	02 06	•	•
HEXAGON GTX (G)	125	00	•	
HEXAGON LX (G)	125	98 99	•	
SKIPPER LX	125	96 97	•	
SKIPPER LX 2T (G)	125	98 99	•	
SKIPPER ST 4T (G)	125	00	•	
SUPERHEXAGON GTX (H)	125	01	•	
SKIPPER LXT 2T	150	98	•	
HEXAGON	180	00	•	
HEXAGON LXT (G)	180	98 99	•	
BV (G)	200	02 06	•	•
HEXAGON GT 4T (G)	250	98 99	•	
HEXAGON GTX (G)	250	00	•	
SUPERHEXAGON GTX	250	01	•	
RIEJU	CC	MY	A	P
RS1 CASTROL	50	01	•	
VESPA	CC	MY	A	P
VESPA GRANTURISMO L (H)	125	03	•	
YAMAHA	CC	MY	A	P
DT R	50	04	•	
DT X SUPERMOTARD	50	04	•	
TZR	50	03 04	•	
XT X	125	05 07	•	

PASTIGLIE FRENO BRAKE PADS

► P.161



SINTERIZZATA
SINTERED
P.161ACX

ORGANICA STRADALE
ROAD ORGANIC
P.161ASX

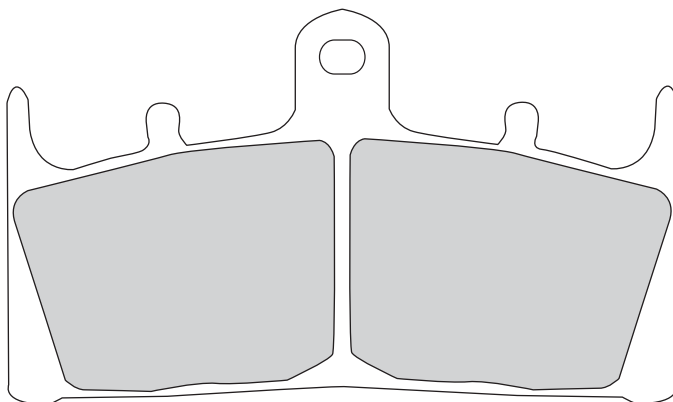

KAWASAKI	CC	MY	A	P
ZRX	400	98	•	
ZX 6R	600	98 01	•	
ZX-6R	636	02 03	•	
ZX 7R	750	96 03	•	
GPZ R A12-A15	900	99 02	•	
ZX 9R B3-B4	900	96 97	•	
ZX 9R C1-C2/E1-E2	900	98 01	•	
ZRX	1100	97 00	•	

ZRX	1200	01 05	•	
ZX 12R	1200	00 03	•	
ZXR R	1200	01 05	•	
ZXR S	1200	01 04	•	
VN MEAN STREAK	1500	01 03	•	
VN MEAN STREAK	1600	04	•	
SUZUKI	CC	MY	A	P
GSX R WR/WS	750	94 95	•	
GSX R-WT-W	750	96 99	•	

GSX R K1-K2	1000	01 02	•	
TL RK1	1000	01 02	•	
GS SS	1200	01	•	
GSF BANDIT S	1200	01 05	•	
GSX RK2/RZK3/RK4-RK5 /K6/K7	1300	02 07	•	
GSX RX/RV/RK1 HAYABUSA	1300	99 01	•	
GSX K1-K7	1400	01 07	•	
VZ K4 MARAUDER	1600	04	•	

► P.164



SINTERIZZATA
SINTERED
P.164ACX

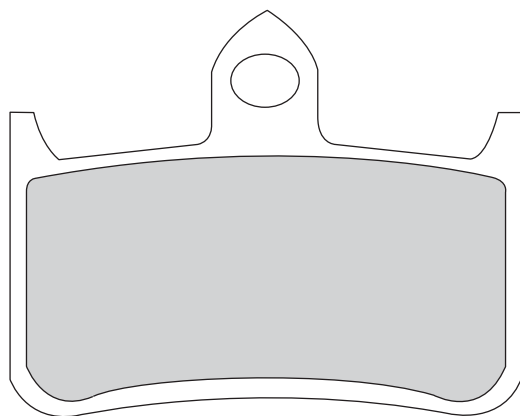

HONDA	CC	MY	A	P
NTV-L-M-N	600	90 92	•	

PASTIGLIE FRENO BRAKE PADS

► P.165

94.2

41.0

10.0

SINTERIZZATA
SINTERED
P.165ACX

ORGANICA STRADALE
ROAD ORGANIC
P.165ASX

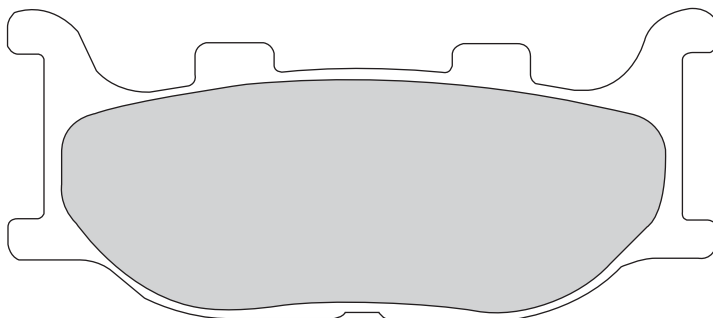

ITALJET	CC	MY	A	P
JUPITER	125	02	•	
JUPITER	150	02	•	
JUPITER	250	02	•	
MBK	CC	MY	A	P
SKYLINER	250	00	•	
SKYLINER	250	01	•	
YAMAHA	CC	MY	A	P
XV VIRAGO	125	97	00	•

XVS DRAG STAR	125	00	04	•	
TZR R	150	00		•	
MAJESTY DE-LUXE	250	98	00	•	
MAJESTY YP	250	04		•	
XV S VIRAGO	250	95	00	•	
XVS DRAG STAR	250	01	04	•	
MAJESTY T / V / W	400	05		•	
XJR R	400	95	96	•	
T MAX	500	04	08	•	

T MAX BLACK MAX	500	06		•	
FZ 6 FAZER	600	04	05	•	
XJ N	600	98	03	•	
XJ S DIVERSION	600	98	03	•	
XV VIRAGO	1100	99	00	•	
XVS A DRAG STAR CLASSIC	1100	00	05	•	
XVS DRAG STAR	1100	99	04	•	

► P.166

 77.4
98.8

 42.3
42.3

 8.3
8.3

SINTERIZZATA
SINTERED
P.166ACX

ORGANICA STRADALE
ROAD ORGANIC
P.166ASX

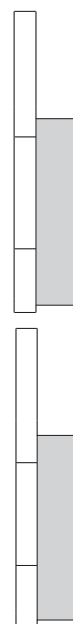
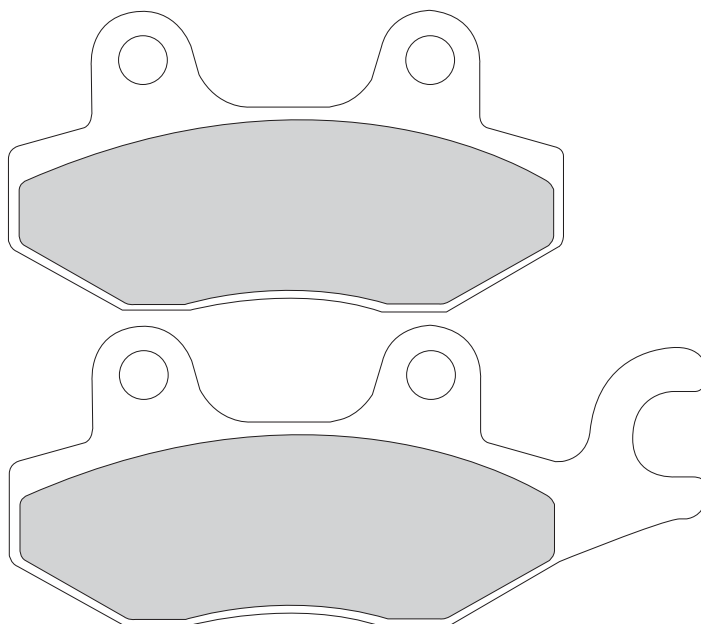

DAELIM	CC	MY	A	P
ROADWIN	125	04		•
S2	125	08		•
S2	250	08		•
HONDA	CC	MY	A	P
TRX ASTREA SUPRA NF	100	99	•	
CA S-T REBEL	125	95	98	•
VT SHADOW	125	99	05	•
XL V VARADERO	125	01	05	•
CMX-CT-V	250	95	98	•
KYMCO	CC	MY	A	P
BET & WIN	50	01		• •
JAGER	50	01		•
YAGER	50	07		•

BET & WIN 4T	125	00		• •
DINK	125	97		• •
DINK LX	125	99		• •
GRAND DINK	125	02		• •
JOYRIDE	125	01		•
MOVIE XL	125	01		•
QUANNON	125	07		• •
STRYKER	125	99		•
YAGER GT	125	07		• •
DINK	150	97		• •
GRAND DINK	150	02		• •
JOYRIDE	150	01		•
MOVIE XL	150	99		•
BET & WIN 4T	250	00		• •

DINK	250	00		• •
GRANDVISTA	250	08		• •
PEOPLE 4T	250	02	05	•
PEOPLE 4T	250	06		•
YUP	250	02		•
SUZUKI	CC	MY	A	P
AN BURGMAN RIGHT	400	07		•
YAMAHA	CC	MY	A	P
TZR THUNDERKID	50	97	00	•
XTZ K/E	125	05	06	•

PASTIGLIE FRENO BRAKE PADS

► P.168



SINTERIZZATA
SINTERED
P.168ACX

ORGANICA STRADALE
ROAD ORGANIC
P.168ASX

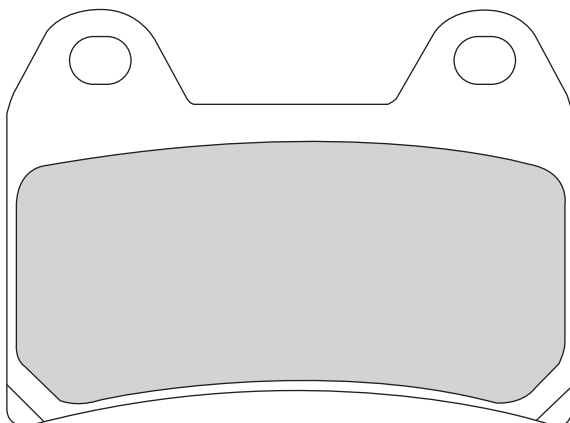

APRILIA	CC	MY	A	P
RS	250	98	•	
PEGASO	650	07	•	
PEGASO STRADA	650	05 06	•	
DORSODURO	750	08	•	
BLUE MARLIN	1000	02	•	
RST FUTURA	1000	01 04	•	
RSV MILLE	1000	98 00	•	
RSV MILLE R	1000	00	•	
RSV MILLE SL FALCO	1000	00	•	
RSV MILLE SP	1000	00	•	
RSV TUONO	1000	02	•	
DORSODURO	1200	11	•	
BENELLI	CC	MY	A	P
TRE-K	899	07	•	
TORNADO	900	02	•	
TNT	1130	05	•	
TNT TITANIUM	1130	05	•	
TNT TORNADO NAKED 3	1130	07	•	
TRE-K	1130	06	•	
TRE-K AMAZONAS	1130	07	•	
BIMOTA	CC	MY	A	P
V DUE EVOLUTION	500	00	•	
DB 4	900	99	•	
SB 8 R SPECIAL	996	99	•	
BMW	CC	MY	A	P
G 650 XMOTO	650	07 09	•	
CAGIVA	CC	MY	A	P
RAPTOR	650	01	•	
V-RAPTOR	650	01	•	
EXTRA-RAPTOR	1000	00 05	•	
RAPTOR	1000	00 05	•	
V-RAPTOR	1000	00 05	•	
DUCATI	CC	MY	A	P
M 600 MONSTER	600	99 01	•	
MONSTER DARK I.E.	618	03	•	
MONSTER I.E.	618	02	•	
MONSTER S I.E.	618	03	•	
SS	618	03	•	
SS	618	04	•	
MULTISTRADA DARK	620	05	•	
696 MONSTER	696	08	•	
748 R	748	00	•	
748 SPS	748	98	•	
749 BIPOSTO	749	98	•	
M 750 MONSTER	750	99 01	•	

SPORT	750	00	•	
SS 750 SUPERSPORT	750	00	•	
796 HYPERMOTARD	796	10	•	
796 MONSTER	796	13	•	
SPORT	802	03	•	
M 800 MONSTER DARK	803	03	•	
M 800 MONSTER S I.E.	803	03	•	
SS	803	03	•	
848	848	08 10	•	
MH 900 (V3)	900	00	•	
M 900 MONSTER	904	00	•	
M 900 MONSTER	904	01	•	
SS 900	904	98 00	•	
SS 900	904	01	•	
916 SPS	916	98	•	
MONSTER S4	916	01	•	
ST 4	916	99 00	•	
ST 4	916	01	•	
ST 2	944	01	•	
ST 3	992	05	•	
996 BIPOSTO	996	98 00	•	
996 BIPOSTO	996	01	•	
996 S	996	99 01	•	
996 SPS	996	98 00	•	
996 SPS	996	01	•	
ST 4S	996	01	•	
ST 4S-ABS	996	03	•	
998	998	02	•	
1000 HF I.E.	1000	03	•	
1000 MULTISTRADA DS	1000	03	•	
1000 SS I.E.	1000	03	•	
MONSTER DARK I.E.	1000	03	•	
MONSTER S I.E.	1000	03	•	
MONSTER S2R	1000	06	•	
MONSTER	1100	09	•	
MONSTER EVO	1100	11	•	
MONSTER S	1100	09	•	
MULTISTRADA	1100	07 09	•	
MULTISTRADA S	1100	07 09	•	
MULTISTRADA	1200	10	•	
HONDA	CC	MY	A	P
CB SF "SUPERFOUR"	400	92 95	•	
HUSQVARNA	CC	MY	A	P
LT	610	00	•	
SM S	610	00 05	•	

KTM	CC	MY	A	P
DUKE	640	03 06	•	
MORINI	CC	MY	A	P
CORSARO	1200	05	•	
MOTO GUZZI	CC	MY	A	P
BREVA I.E.	750	03	•	
NEVADA CLASSIC I.E.	750	03	•	
NEVADA CLUB	750	03 04	•	
STR V I.E.	750	03	•	
BREVA	850	06	•	
GRISO	850	06	•	
EV STONE	1000	02	•	
V 11 SPORT BALLABIO	1000	03	•	
BREVA V	1100	05	•	
GRISO	1100	05	•	
V 11 LE MANS	1100	03	•	
V 11 SCURA	1100	03	•	
V 11 SPORT	1100	00	•	
NORGE	1200	06	•	
NORGE 1200 GT 8V	1200	11	•	
SPORT	1200	07	•	
MUZ	CC	MY	A	P
S	1000	01	•	
SUZUKI	CC	MY	A	P
GSX INAZUMA FSW/FSX	1200	98 99	•	
VICTORY	CC	MY	A	P
8-BALL	1500	05	•	
ARLEN NESS	1500	04	•	
HAMMER	1500	05	•	
HAMMER S	1500	07	•	
KING PIN	1500	04	•	
KING PIN TOUR	1500	07	•	
TOURING CRUISER	1500	03	•	
V92C CRUISER	1500	98 02	•	
V92C DELUXE	1500	01 02	•	
V92SC SPORT CRUISER	1500	00 02	•	
VEGAS	1500	03	•	
VEGAS JACKPOT	1500	06	•	
VOXAN	CC	MY	A	P
VB1 EVO	1000	04	•	
YAMAHA	CC	MY	A	P
XJR R	400	97 00	•	
XT X SUPERMOTO	660	04 07	•	
XJR	1300	98	•	

PASTIGLIE FRENO BRAKE PADS

► P.169



131.9
109.0



37.2
44.0



8.4
8.5

SINTERIZZATA
SINTERED
P.169ACX

ORGANICA STRADALE
ROAD ORGANIC
P.169ASX

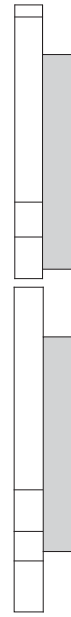
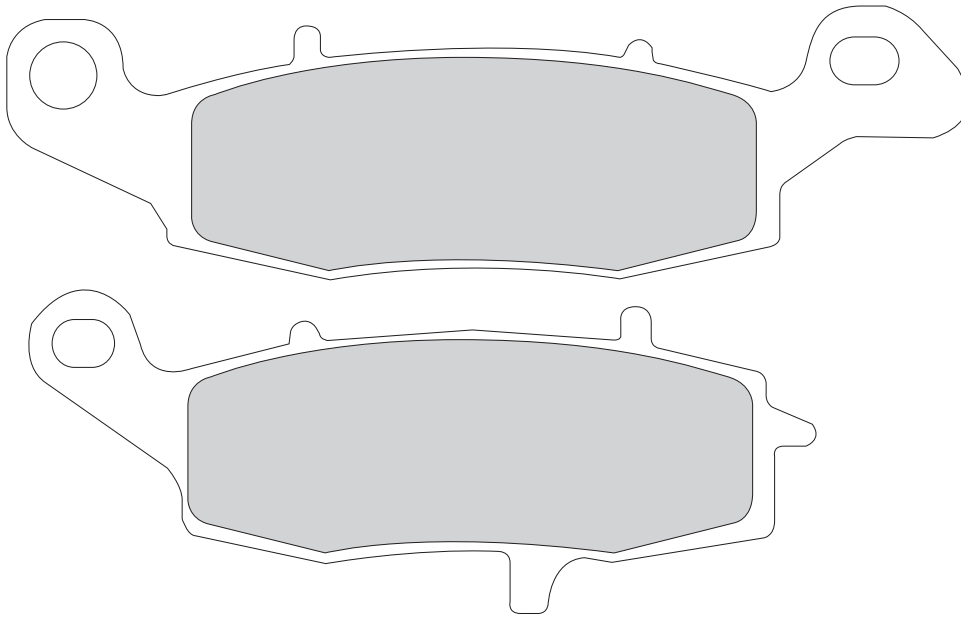

KAWASAKI	CC	MY	A	P
ER-5	500	01 05	•	
KLR C1-C8	650	94 04	•	
Z S P.SX	750	05	•	
ZR 7S P.SX	750	01 04	•	
VN B1-B10 CLASSIC	800	96 05	•	
VN C1-C2/E1-E3 DRIFTER	800	99 04	•	
VN CUSTOM	900	07	•	
VN VULCAN CLASSIC	900	06	•	
ZR ZEPHYR B1 P.SX	1100	96 98	•	
ZR ZEPHYR B5 P.SX	1100	02	•	

VN CLASSIC	1500	96	•	
VN CLASSIC TOURER P.SX	1500	98 02	•	
VN DRIFTER	1500	02	•	
VN TOURER P.SX	1500	03	•	
VN SUMO CLASSIC P.SX	1600	03	•	
SUZUKI	CC	MY	A	P
GSF VS/S BANDIT	250	97	•	
TU GY/GBK1	250	00 01	•	
GSF BANDIT P.SX	600	00 04	•	
GSX FW/FX/FY/FK1-FK3	600	98 04	•	
DL V-STROM LEFT	650	04	•	

GSF BANDIT / S BANDIT RIGHT	650	05	•	
SV K3/SK3 P.SX	650	03 05	•	
SV SK3-SK7 PINZA SX	650	03 07	•	
SV X/SX/Y/SY/K1/SK1-SK2	650	99 02	•	
GSX W/X/Y/K1 P.SX	750	98 03	•	
VX L/M/N/P/R	800	90 96	•	
DL K2-K7 V-STORM P. SX	1000	02 07	•	
VL K2-K3 INTRUDER LC	1500	02 03	•	
VL K5-K6-K7 INTRUDER LC	1500	05 07	•	

PASTIGLIE FRENO BRAKE PADS

► **P.171**



131.9
109.0



37.2
44.0



8.4
8.5

SINTERIZZATA
SINTERED
P.171ACX

ORGANICA STRADALE
ROAD ORGANIC
P.171ASX

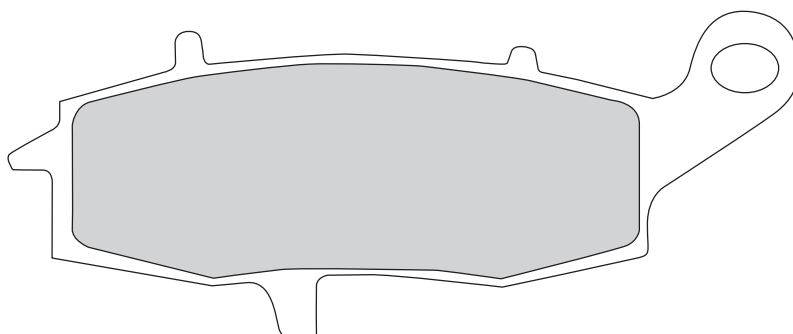
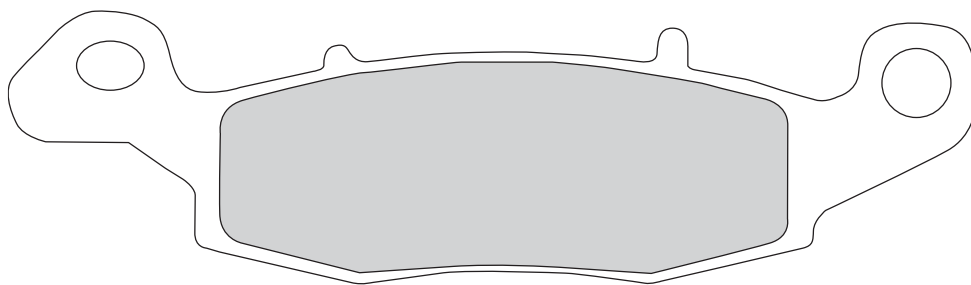

KAWASAKI	CC	MY	A	P
BJ F1-F2	250	02 03	•	
ZR B6 BALIUS II	250	02	•	
Z S P.DX	750	05	•	
ZR 7S P.DX	750	01 04	•	
ZR 7S P.SX	750	01 04		•
VN C1-C2/E1-E3 DRIFTER	800	99 04		•
VN CUSTOM	900	07		•
VN VULCAN CLASSIC	900	06		•
ZR ZEPHYR B1 P.SX	1100	96 98	•	
ZR ZEPHYR B5 P.SX	1100	02	•	
VN CLASSIC TOURER P.SX	1500	98 02	•	
VN DRIFTER	1500	02		•
VN MEAN STREAK	1500	01 03		•
VN TOURER P.DX	1500	03		•
VN TOURER P.SX	1500	03		•

VN MEAN STREAK	1600	04			•
VN SUMO CLASSIC P.SX	1600	03			•
VN A VULCAN	2000	04			•
SUZUKI	CC	MY	A	P	
RV K2/K3/K4 VAN-VAN	125	02 05	•		
RV K2/K3	200	02 03	•		
GSX FXK2	250	02	•		
TU XTX/XXTY	250	99 00		•	
SV	400	99		•	
GS ET/EV/EW/EX/EY/K1-K4	500	89 03	•		
GS FK4/FK5/K5	500	04 05	•		
GSF BANDIT P.DX	600	00 04	•		
GSX FW/FX/FY/FK1-FK3	600	98 04	•		
DL V-STROM RIGHT	650	04		•	
GSF BANDIT / S BANDIT RIGHT	650	05		•	
SV K3/SK3 P.DX	650	03 05		•	

SV SK3-SK7 PINZA SX	650	03 07	•	
SV X/SX/Y/SY/K1/SK1-SK2	650	99 02	•	
XF V/W/X/Y FREEWIND	650	97 02	•	
GSX W/X/Y/K1 P.SX	750	98 03	•	
VL K1-K4 INTRUDER VOLUSIA	800	01 04	•	
VL K5/K6/K7 INTRUDER	800	05 07	•	
VS K5 INTRUDER	800	05		•
VZ K5/K6/K7 M INTRUDER	800	05 07	•	
VZ V/W/X/Y/K1-K4 MARAUDER800	97	04	•	
DL K2-K7 V-STORM P. SX	1000	02 07	•	
VL K2-K3 INTRUDER LC	1500	02 03	•	
VL K5-K6-K7 INTRUDER LC	1500	05 07		•
VZ K4 MARAUDER	1600	04		•
VZ K5 INTRUDER	1600	05		•

► **P.172**



78.0



40.8



9.0

SINTERIZZATA
SINTERED
P.172ACX

ORGANICA STRADALE
ROAD ORGANIC
P.172ASX

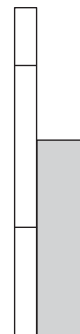
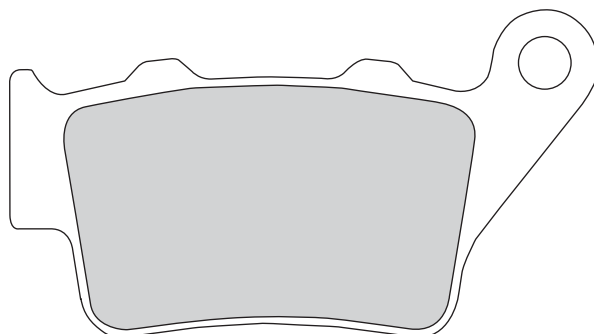

ALFER	CC	MY	A	P
VRE 4-STROKE	125	00		•
NO LIMITS	250	95		•
VR ENDURO	250	95		•

VR MOTOCROSS	250	95		•
VR SUPERMOTARD	250	99		•
APRILIA	CC	MY	A	P
PEGASO	650	07		•

PEGASO	650	06		•
PEGASO I.E.	650	01 04		•
PEGASO STRADA	650	05 06		•
DORSODURO	750	08		•

► P.172

APRILIA	CC	MY	A	P
DORSODURO	750	09		•
SHIVER	750	07		•
MANA	850	07		•
PEGASO	1000	01		•
DORSODURO	1200	11		•
BENELLI	CC	MY	A	P
BX	450	07		•
BETA	CC	MY	A	P
JONATHAN	125	00	01	•
EURO	350	00	01	•
BMW	CC	MY	A	P
C1	125	99	03	•
C1	200	01	03	•
F 650	650	93	00	•
F 650 CS / SCARVER	650	00	06	•
F 650 GS	650	93	07	•
F 650 GS	650	08	09	•
F 650 GS	650	10		•
F 650 GS DAKAR	650	93	07	•
F 650 ST	650	93	00	•
G 650 XCHALLENGE	650	07		•
G 650 XCOUNTRY	650	07	09	•
G 650 XMOTO	650	07	09	•
F 800 R	800	09		•
S 1000 RR	1000	10		•
DUCATI	CC	MY	A	P
GT 1000 SPORT	992	06		•
PAUL SMART LIMITED	992	06		•
SPORT CLASSIC	992	06		•
SPORT	1000	06		•
GAS GAS	CC	MY	A	P
EC (BREMBO)	125	97	99	•
EC (BREMBO)	200	97	99	•
EC (BREMBO)	250	97	99	•
FSE 4T	250	99		•
MC	250	99		•
TT	250	95		•
EC (BREMBO)	300	97	99	•
FSE 4T	400	99		•
HONDA	CC	MY	A	P
CB V/W/SW/X/SX/Y/SY	500	97	03	•
FX VIGOR	650	99	03	•
NX DOMINATOR-T-K-L-M-N	650	87		•
SLR	650	97	98	•
HUSABERG	CC	MY	A	P
SM S	125	00		•
FC	350	95		•
FE	350	95		•
MC	350	94		•
FC	400	99	02	•
FE	400	00		•
FC	450	98	03	•
FE E	450	04	08	•
FX	450	03	09	•
FC	470	01		•
FX E	470	01		•
FC	501	95		•
FE	501	95		•

MC	501	94		•
FC	550	01		•
FE E	550	04		•
FC	600	95		•
FE	600	95		•
FE E	650	01		•
FS	650	01		•
FX E	650	01		•
HUSQVARNA	CC	MY	A	P
CR	125	96	04	•
SM S	125	02		•
WR	125	95	05	•
WRE	125	94	00	•
WRE	125	01		•
CR	250	96	04	•
TC	250	02	03	•
TE	250	02	05	•
WR	250	93	05	•
TE	350	95	97	•
CR	360	94		•
WR	360	94		•
SM R	400	02		•
TE	400	02		•
TE	410	94	05	•
TE E	410	01		•
SM R	450	03	06	•
TC	450	03	04	•
TE	450	03	04	•
SM R	510	01	04	•
SM R	510	05		•
TC	510	04		•
TE	510	04		•
TE	510	05		•
SM R	570	01		•
SM S	570	01		•
TC	570	01		•
TE	570	01	04	•
LT	610	00		•
SM R	610	00	05	•
SM R	610	06		•
SM S	610	00	05	•
SM S	610	06		•
TC	610	95		•
TE	610	95	99	•
TE E	610	00	03	•
TE E	610	04		•
SMR	630	06		•
STR CRC	650	07		•
KTM	CC	MY	A	P
EXC-EGS-SX	125	95	97	•
EXC-EGS-SX	125	98	03	•
EXE	125	00		•
GS	125	94	97	•
LC 2	125	98	00	•
MX SUPERMOTO	125	00		•
SX	125	94	97	•
SX	125	98	03	•
EGS	200	99	02	•
EXC	200	98	02	•
EXC-EGS-SX	250	96	02	•
GS	250	94		•

SX-EGS-EXC	250	96	02	•
LC 4 EXC	350	94		•
LC 4 EGS	400	94		•
EXC RACING	450	03		•
SX	450	94	02	•
SX RACING	450	03		•
EXC RACING	525	03		•
SX RACING	525	03		•
SXC	540	99		•
MG-SX	550	94		•
4T GS	600	94		•
DUKE	620	95	98	•
DUKE II	620	99	02	•
LC 4 EXC-EGS-SX	620	94	02	•
LC4 SXC SUPERMOTO	620	98	02	•
SC	620	99		•
LC4 SUPERCOMPETITION	625	02		•
DUKE	640	03	06	•
LC 4 ADVENTURE R	640	98		•
LC 4 ENDURO	640	99		•
LC 4 SUPERMOTO	640	99	02	•
LC 4 SUPERMOTO	640	03		•
LC 4 SMC SUPERMOTO	660	03		•
DUKE	690	08		•
DUKE R	690	10		•
SM	690	07		•
DUKE	950	03		•
DUKE	990	04		•
SUPERDUKE	990	05		•
SUPERDUKE R	990	09	10	•
MAICO	CC	MY	A	P
ENDURO	250	99		•
MOTOCROSS	250	99		•
ENDURO	500	99		•
MOTOCROSS	500	99		•
SUPERMOTARD	500	99		•
MOTO TM	CC	MY	A	P
GS-MC	80	93		•
CROSS	125	00		•
ENDURO	125	00	03	•
GS-MC	125	93		•
ENDURO 4T	250	00	03	•
CROSS 4T	400	00		•
VERTEMATI	CC	MY	A	P
492 ENDURO	500	99		•
492 SUPERMOTARD	500	99		•
495 CROSS	500	99		•
C	500	01		•
VOR	CC	MY	A	P
MX	350	01		•
ENDURO	400	00		•
492 ENDURO	500	99		•
492 SUPERMOTARD	500	00		•
495 CROSS	500	99		•
ENDURO	530	01		•
YAMAHA	CC	MY	A	P
XT R	660	04	05	•
XT X SUPERMOTO	660	04	07	•

► P.173



ORGANICA STRADALE
ROAD ORGANIC
P.173ASX

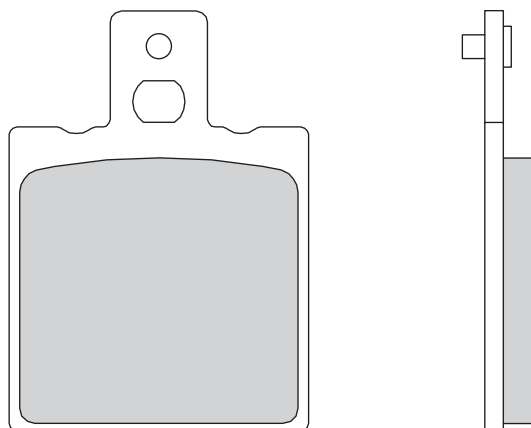

APRILIA	CC	MY	A	P
RS EXTREMA	50	94	•	
SR	50	93 00	•	
SR EUROPA	50	94	•	
SR RACING KAT.	50	00	•	
SR REPLICA	50	93	•	
SR URBAN	50	94	•	
PEGASO	650	94 95		•
CAGIVA	CC	MY	A	P
CUCCILOLO	125	99	•	
MALAGUTI	CC	MY	A	P
CIAK	125	01 02	•	
F 18 WARRIOR	125	00 03	•	
CIAK	150	01 02	•	

F 18 WARRIOR	150	00	03	•	
MBK	CC	MY	A	P	
BOOSTER N.G.	50	95 98	•		
BOOSTER N.G.	50	99	•		
BOOSTER R	50	93 95	•		
BOOSTER SPIRIT	50	95 98	•		
BOOSTER SPIRIT	50	99	•		
BOOSTER TRACK	50	96	•		
FORTE	50	94	•		
NITRO	50	97	•		
OVETTO	50	98	•		
NITRO	100	00	•		
DOODO	125	99	•		
DOODO	150	99	•		

PIAGGIO	CC	MY	A	P
SFERA	50	96	•	
YAMAHA	CC	MY	A	P
AEROX	50	97	•	
BW'S BUMP	50	96	•	
BW'S R	50	95	•	
JOG	50	92	•	
JOG R	50	94	•	
NEO'S	50	97	•	
AEROX	100	00	•	
NEO'S	100	00	•	

► P.175



SINTERIZZATA
SINTERED
P.175ACX

ORGANICA STRADALE
ROAD ORGANIC
P.175ASX

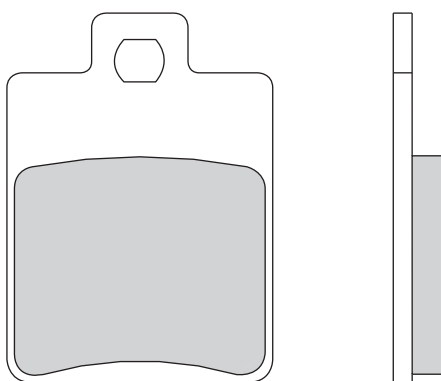

CPI	CC	MY	A	P
OLIVER SPORT	150	08		•
GTR/GTS	180	08		•
GILERA	CC	MY	A	P
NRG-MC2	50	99 00	•	
NRG-MC3	50	01	•	
RUNNER	50	97	•	
RUNNER DD	50	97	•	
RUNNER SP	50	01 04	•	•
RUNNER SP	50	05	•	
STALKER DD	50	99	•	
STALKER DT	50	99	•	
TYPHOON	50	96 00	•	
TYPHOON X	50	01	•	

RUNNER SP	125	98 00	•	
RUNNER FXR (G)	180	00	•	
RUNNER FXR (H)	180	00	•	
RUNNER FXR SP (G)	180	99	•	
RUNNER FXR SP (H)	180	99	•	
RUNNER SP	200	99	•	
FUOCO I.E.	500	07	•	
PEUGEOT	CC	MY	A	P
SATELIS CITY	250	06	•	
PIAGGIO	CC	MY	A	P
FLY (U.S.)	50	05	•	
LIBERTY	50	97 07	•	
LIBERTY 4T	50	00 07	•	
LIBERTY S	50	08	•	

LIBERTY S 4T	50	08	•	
NRG EXTREME	50	01	•	•
NRG EXTREME ACQUA	50	96 00	•	
NRG POWER DD	50	05	•	
NRG=MC2	50	99	•	
SFERA ET2	50	97	•	
ZIP 4T KAT.	50	00	•	
ZIP FAST RIDER	50	93	•	
ZIP FAST RIDER	50	00	•	
ZIP II	50	01	•	
ZIP RST	50	96 99	•	
ZIP RST	50	00	•	
ZIP SP L.C.	50	96 99	•	
ZIP SP L.C.	50	00	•	

PASTIGLIE FRENO BRAKE PADS

► P.175

PIAGGIO	CC	MY	A	P
TYPHOON	80	96	•	
ZIP	100	07	•	
LIBERTY 4T	125	97 99	•	
LIBERTY 4T	125	00 07	•	
LIBERTY S 4T	125	07	•	
SFERA 4T	125	96	•	

ZIP 4T KAT.	125	00	•	
HEXAGON	150	94 99	•	
LIBERTY 4T	150	00	•	
HEXAGON	180	00	•	
VESPA	CC	MY	A	P
VESPA ET2	50	99	•	
VESPA ET4 (G)	50	01	•	
VESPA LX 2T	50	05	•	
VESPA LX 4T	50	05	•	

VESPA ET4	125	97 99	•	
VESPA ET4	125	00	•	
VESPA LX	125	05 07	•	
VESPA ET4	150	99	•	
VESPA LX	150	05 07	•	
VESPA LXV	150	05 08	•	

► P.176



ORGANICA STRADALE
ROAD ORGANIC
P.176ASX

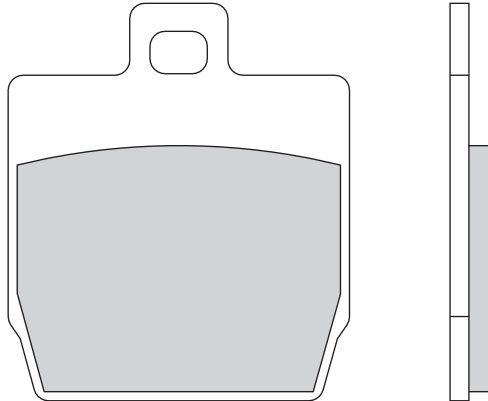

MBK	CC	MY	A	P
NITRO	50	97	•	
YAMAHA	CC	MY	A	P
AEROX	50	97	•	

SLIDER	50	00	•	
AEROX	100	00	•	

► P.177



SINTERIZZATA
SINTERED
P.177ACX

ORGANICA STRADALE
ROAD ORGANIC
P.177ASX

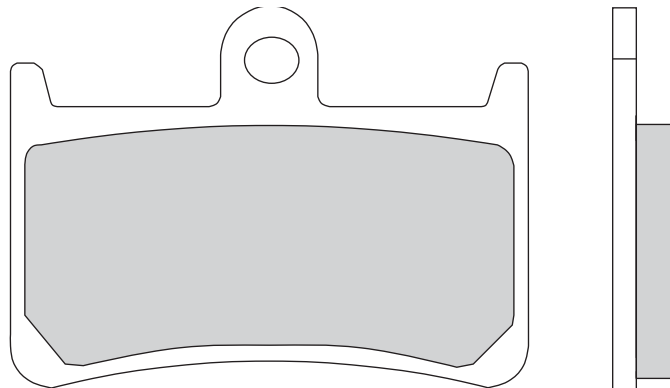

YAMAHA	CC	MY	A	P
TZR	125	93	•	
TZR	250	87 92	•	
TZR R	250	91	•	
FZR RR (4DX)	400	92	•	
XJR R	400	01	•	
T MAX	500	09 11	•	
T MAX SV	500	11	•	
XP T MAX	530	12	•	
FZS FAZER	600	98 03	•	
FZS FAZER SP	600	00 03	•	
YZF R THUNDER CAT	600	96 03	•	

YZF R6	600	99 02	•	
YZF R6	600	03 07	•	
YZF R6 S	600	07	•	
YZF 7R OW02	750	99 00	•	
TDM AT/AV/AW (ABS)	900	05 07	•	
TDM P/R/S/T/V	900	02 06	•	
FZ1	1000	06	•	
FZS FAZER	1000	01 05	•	
YZF THUNDER ACE	1000	96 02	•	
YZF R1	1000	98	•	
YZF R1	1000	99 01	•	
YZF R1	1000	02 03	•	

YZF R1	1000	04 06	•	
BT BULLDOG P/R/S/T	1100	02 05	•	
FJR N/P	1300	01 02	•	
FJR R/AR/S/AS/AT	1300	03 05	•	
XJR P/R/S/T	1300	02 05	•	
XJR/XJR SP	1300	99 01	•	
MT-01	1700	05 06	•	
XV MIDNIGHT STAR	1700	06	•	
XV PC ROAD STAR WARRIOR	1700	03	•	
XV PCR ROAD STAR WARRIOR	1700	03 05	•	
XV ROAD STAR WARRIOR	1700	02	•	

PASTIGLIE FRENO BRAKE PADS

▶ P.180



SINTERIZZATA
SINTERED
P.180ACX

ORGANICA STRADALE
ROAD ORGANIC
P.180ASX

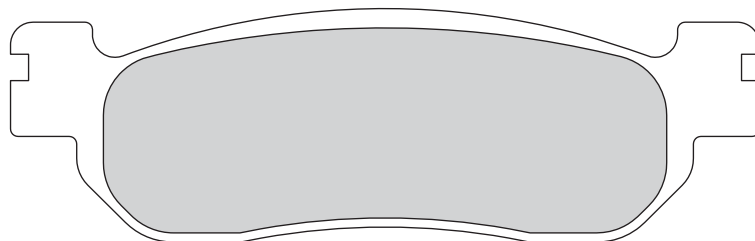

ITALJET	CC	MY	A	P
JUPITER	125	02		•
JUPITER	150	02		•
MBK	CC	MY	A	P
SKYLINER	250	01		•

YAMAHA	CC	MY	A	P
X-CITY	125	08		•
X-MAX	125	06		•
X-MAX	125	10		•
XT	225	01	07	•
MAJESTY DE-LUXE	250	98	00	•

MAJESTY YP	250	01	03	•
X-CITY	250	07		•
X-MAX	250	04	09	•
X-MAX	250	10		•

▶ P.182



SINTERIZZATA
SINTERED
P.182ACX

ORGANICA STRADALE
ROAD ORGANIC
P.182ASX

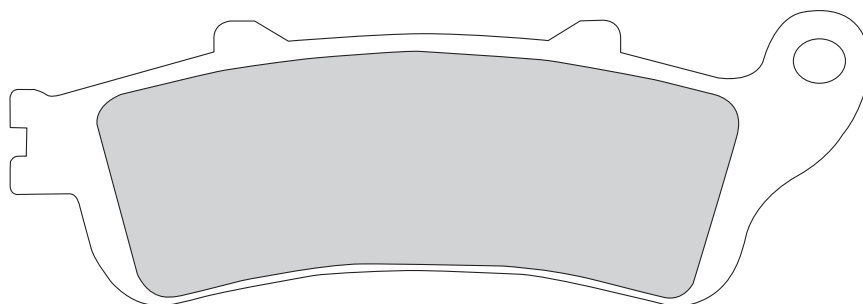

HONDA	CC	MY	A	P
NT DEAUVILLE	650	02	04	•
NTV V	650	02		•
NTV V DEAUVILLE	700	06		•
VFR A6/A7	800	06	07	•
VFR F	800	98	99	•

VFR F	800	00	02	•
VARADERO	1000	99	00	•
XL VA4-VA5-VA6-VA7 VARADERO	1000	04	07	•
XL VX/XY/V1-V5 VARADERO	1000	99	05	•
CBR XXV/XXW BLACKBIRD	1100	97	98	•
CBR XXX/XXY BLACKBIRD	1100	99	05	•

ST L R-AN V PAN EUROPEAN	1100	90	95	•
ST PAN EUROPEAN	1300	02		•
GL GOLDWING	1800	01	05	•
VTX C2/C3/C4	1800	02	04	•

▶ P.183



SINTERIZZATA
SINTERED
P.183ACX

ORGANICA STRADALE
ROAD ORGANIC
P.183ASX

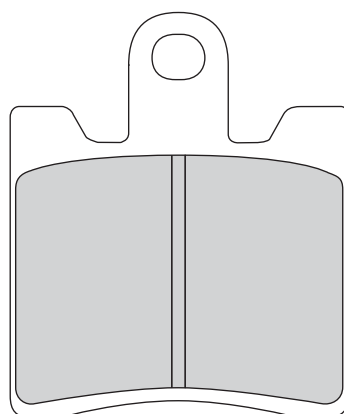

SUZUKI	CC	MY	A	P
AN BURGMAN	250	98	03	•
AN BURGMAN	250	07		•

AN BURGMAN BUSINESS	250	01	02	•
AN BURGMAN	400	98	03	•

SYM	CC	MY	A	P
RV	250	07		•
GT	500	04		•

PASTIGLIE FRENO BRAKE PADS

► P.184



SINTERIZZATA
SINTERED
P.184ACX

ORGANICA STRADALE
ROAD ORGANIC
P.184ASX

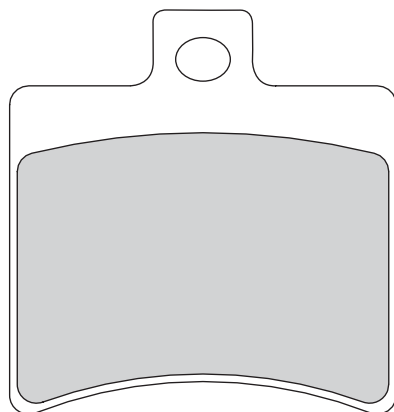

APRILIA	CC	MY	A	P
SR R FACTORY	50	05 06		•
SR RACING KAT.	50	00		•
SR STREET	50	07		•
ATLANTIC	125	03 06		•
RS 125	125	06		•
SCARABEO	125	07		•
SCARABEO	125	98 03		•
SCARABEO GT	125	04 06		•
SPORTCITY	125	05		•
LEONARDO 4T	150	99 04		•
SCARABEO	150	98 03		•
SCARABEO GT	150	04 06		•
ATLANTIC	200	03 04		•
ATLANTIC	200	05		•
SCARABEO	200	07		•
SCARABEO	200	01 02		•
SCARABEO GT	200	03 06		•
SPORTCITY	200	05 06		•
ATLANTIC	250	03 04		•

ATLANTIC	250	05 06		•
LEONARDO	250	99 00		•
LEONARDO	250	01 04		•
SCARABEO	250	04 05		•
SCARABEO	250	06		•
SCARABEO I.E.	250	07		•
SPORTCITY I.E.	250	07		•
LEONARDO	300	05		•
SCARABEO S	300	09		•
ATLANTIC SPRINT	400	07		•
SCARABEO I.E.	400	07		•
ATLANTIC	500	02 04		•
ATLANTIC SPRINT	500	05 07		•
SCARABEO ABS	500	03 06		•
SCARABEO CLASS	500	10		•
SCARABEO I.E.	500	07		•
BENELLI	CC	MY	A	P
VELVET	250	98 00		•
VELVET	250	01 07		•
VELVET DUSK	400	03		•

BETA	CC	MY	A	P
EIKON	125	00 05		•
EIKON	150	00 05		•
MALAGUTI	CC	MY	A	P
F 12 PHANTHOM MAX	125	04		•
F 18 WARRIOR	125	00 03		•
MADISON	125	99		•
MADISON R	125	06		•
F 18 WARRIOR	150	00 03		•
MADISON	150	99		•
MADISON	180	01		•
MADISON S	200	04		•
MADISON	250	99 00		•
MADISON	250	01 04		•
MADISON RS	250	05		•
PASSWORD	250	05		•
MADISON	400	02 04		•
MADISON K	400	05		•
SPIDERMAX GT	500	04		•

► P.185



SINTERIZZATA
SINTERED
P.185ACX

ORGANICA STRADALE
ROAD ORGANIC
P.185ASX

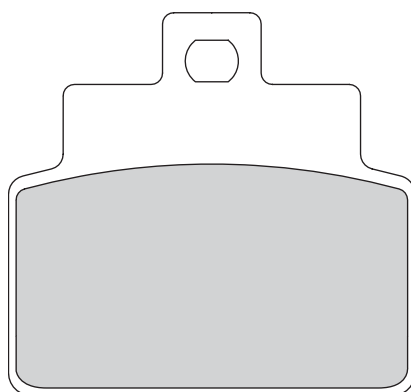

APRILIA	CC	MY	A	P
SCARABEO	50	03		•
SCARABEO	100	00 02		•
HABANA	125	00		•
LEONARDO	125	99 06		•
SR	125	99		•
LEONARDO 4T	150	99 04		•
MOJITO	150	99 05		•

PASTIGLIE FRENO BRAKE PADS

► P.186



SINTERIZZATA
SINTERED
P.186ACX

ORGANICA STRADALE
ROAD ORGANIC
P.186ASX

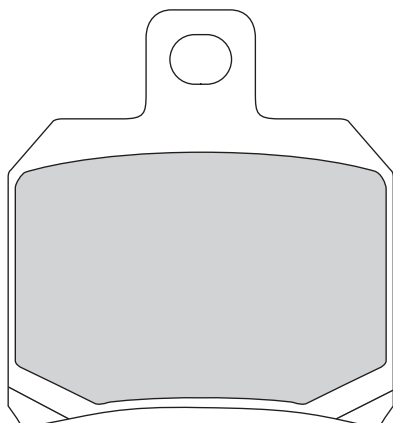

APRILIA	CC	MY	A	P
RS	50	07	•	
BLUE MARLIN	1000	02		•
ETV-CAPONORD/RAID	1000	01 02		•
RSV FACTORY	1000	04		•
RSV MILLE	1000	98 00		•
RSV MILLE	1000	01 05		•
RSV MILLE NERA	1000	04		•
RSV MILLE R	1000	00		•
RSV MILLE R	1000	01 07		•
RSV MILLE SL FALCO	1000	00		•
RSV MILLE SP	1000	00		•
RSV TUONO	1000	02		•
RSV TUONO RACING	1000	04		•
RSV4 FACTORY	1000	09		•
RSV4 R	1000	10		•
RSVR	1000	09		•
BENELLI	CC	MY	A	P
TRE-K	899	07		•
TORNADO 3	900	03 05		•
TNT	1130	06		•
TNT	1130	05		•
TNT SPORT	1130	04 07		•
TNT TITANIUM	1130	05		•
TNT TITANIUM	1130	06		•
TNT TORNADO NAKED 3	1130	07		•
TORNADO 3	1130	06		•
TRE-K	1130	06		•
TRE-K AMAZONAS	1130	07		•
BIMOTA	CC	MY	A	P
DB 5 MILLE	992	05		•
DB 5	1078	06 07		•
DB 5 R	1078	06 07		•
DB 6 DELIRIO	1078	07		•
TESI III D	1078	07		•
CAGIVA	CC	MY	A	P
RAPTOR	650	01		•
V-RAPTOR	650	01		•
EXTRA-RAPTOR	1000	00 05		•
RAPTOR	1000	00 05		•
V-RAPTOR	1000	00 05		•
X3-RAPTOR	1000	03 04		•
DERBI	CC	MY	A	P
GP 1	125	06		•
GP 1	250	05		•
DUCATI	CC	MY	A	P
M620	618	05		•
M620 DARK	618	05		•

MONSTER DARK I.E.	618	03		•
MONSTER I.E.	618	02		•
MONSTER S I.E.	618	03		•
SS	618	03		•
SS	618	04		•
MULTISTRADA	620	05		•
MULTISTRADA DARK	620	05		•
696 MONSTER	696	08		•
748 R	748	01 02		•
749	749	03 06		•
749 DARK	749	04 06		•
749 R	749	03 06		•
749 S	749	03 06		•
SPORT	750	00		•
SS 750 SUPERSPORT	750	00		•
796 HYPERMOTARD	796	10		•
796 MONSTER	796	13		•
M 800 MONSTER DARK	803	03		•
M 800 MONSTER S I.E.	803	03		•
S2 R	803	05		•
S2 R DARK	803	05		•
HYPERMOTARD	821	13		•
HYPERMOTARD SP	821	13		•
HYPERSTRADA	821	13		•
848	848	08 10		•
848 EVO	848	11		•
M 900 MONSTER	904	00		•
M 900 MONSTER	904	01		•
SS 900	904	98 00		•
SS 900	904	01		•
916 SPS	916	98		•
MONSTER S4	916	01		•
ST 4	916	99 00		•
ST 4	916	01		•
ST 2	944	97 00		•
ST 2	944	01		•
DESMOSEDICI (DD16RR)	990	08		•
ST 3	992	05		•
ST 4S	996	01		•
ST 4S-ABS	996	03		•
998 MATRIX	998	04		•
S4 RS MONSTER	998	05		•
999	999	03 06		•
999 R	999	03 06		•
999 S	999	03 04		•
1000 HF I.E.	1000	03		•
1000 MULTISTRADA DS	1000	03		•
1000 SS I.E.	1000	03		•

MONSTER S2R	1000	06		•
1098	1099	07 08		•
1098 R	1099	08 09		•
1098 S	1099	07 08		•
1098 TRICOLORE	1099	07		•
STREETFIGHTER	1099	09		•
STREETFIGHTER S	1099	09		•
1198	1100	09		•
1198 S	1100	09		•
HYPERMOTARD	1100	07 09		•
HYPERMOTARD EVO	1100	10		•
HYPERMOTARD S	1100	07 09		•
HYPERMOTARD EVO SP	1100	10		•
MONSTER	1100	09		•
MONSTER EVO	1100	11		•
MONSTER S	1100	09		•
MULTISTRADA	1100	07 09		•
MULTISTRADA S	1100	07 09		•
PANIGALE	1199	12		•
PANIGALE S	1199	12		•
MULTISTRADA	1200	10		•
GILERA	CC	MY	A	P
NEXUS	500	04		•
SUPERSPORT	600	02		•
KTM	CC	MY	A	P
R RC8 R	1190	09		•
R RC8 R TRACK	1190	09		•
RC8	1190	08		•
LAVERDA	CC	MY	A	P
SFC	1000	03		•
MBK	CC	MY	A	P
SKYLINER	125	02		•
THUNDER	125	02		•
SKYLINER	150	00		•
THUNDER	150	01		•
SKYLINER	180	03		•
MONDIAL	CC	MY	A	P
EVO	1000	04		•
PIEGA	1000	03		•
RZ NUDA	1000	04		•
STARFIGHTER	1000	04		•
MORINI	CC	MY	A	P
CORSARO	1200	05		•
MOTO GUZZI	CC	MY	A	P
NEVADA CLASSIC I.E.	750	03		•
NEVADA CLUB	750	03 04		•
BREVA	850	06		•
GRISO	850	06		•

PASTIGLIE FRENO BRAKE PADS

► P.186

MOTO GUZZI	CC	MY	A	P
EV STONE	1000	02		•
V 11 SPORT BALLABIO	1000	03		•
FIONDA	1100	05		•
MUZ	CC	MY	A	P
S	1000	01		•
PEUGEOT	CC	MY	A	P
SATELIS CITY	250	06	•	
SATELIS	500	06	•	•
PIAGGIO	CC	MY	A	P
X 8 4T	125	04	05	•
X 9	125	00	02	•
X 9 EVOLUTION	125	03	05	•

X 9 EVOLUTION	125	06		•	
X 9 AMALFI	180	00	03	•	•
X 8 4T	200	04	05	•	
X 9 AMALFI	200	01	02	•	•
X 9 EVOLUTION	200	03	04	•	•
X 9	250	00	04	•	•
BEVERLY I.E.	400	07		•	
BEVERLY	500	06		•	
BEVERLY B 4T	500	02	05	•	•
BEVERLY I.E.	500	07		•	•
BV	500	06	08	•	•
X 9	500	00	02	•	•
X 9 EVOLUTION ABS	500	03	06	•	•
X 9 I.E.	500	07		•	•

SUZUKI	CC	MY	A	P
UH BURGMAN	125	02	06	•
UH BURGMAN	150	03		•
VOXAN	CC	MY	A	P
CAFE'RACER	1000	01		•
ROADSTER	1000	01		•
VB1 EVO	1000	04		•
YAMAHA	CC	MY	A	P
MAJESTY SP	125	01		•
MAXSTER	125	01		•
MAJESTY 4T	150	99		•
MAXSTER	150	01		•
MAJESTY SP	180	03		•

► P.187



75.0



55.3



8.3

SINTERIZZATA
SINTERED
P.187ACX

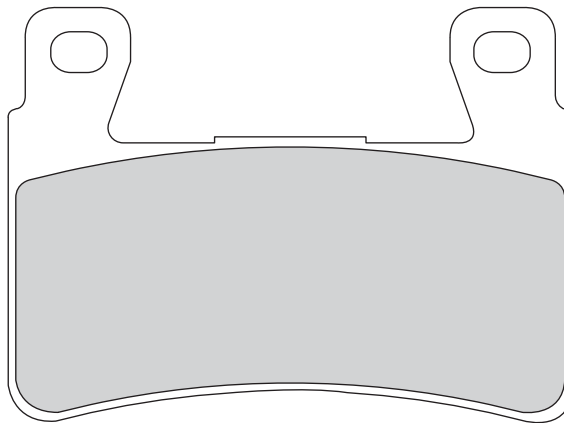

HONDA	CC	MY	A	P
CB SBS	400	05		•
CB SFX/SFY "SUPERFOUR"	400	99	03	•
CB SS	400	02		•
CBR F	600	99	01	•
CBR F4 SPORT	600	02	03	•

CBR RR	600	03	04	•	
CBR RR	900	98	99	•	•
CBR RR	929	00	01	•	•
CBR RR	954	02	03	•	•
VTR SP 1	1000	00	01	•	•
VTR SP 2	1000	02	05	•	•

CB A5	1300	04		•	
CB F1	1300	01	02	•	•
CB F3/F13	1300	03		•	•
CB SS	1300	04		•	•

► P.188



85.1



44.3



8.0

ORGANICA STRADALE
ROAD ORGANIC
P.188ASX

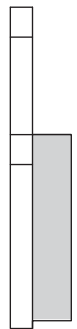
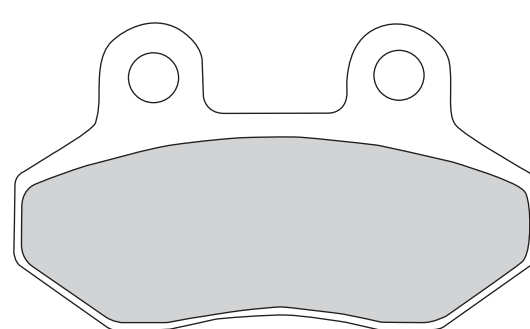
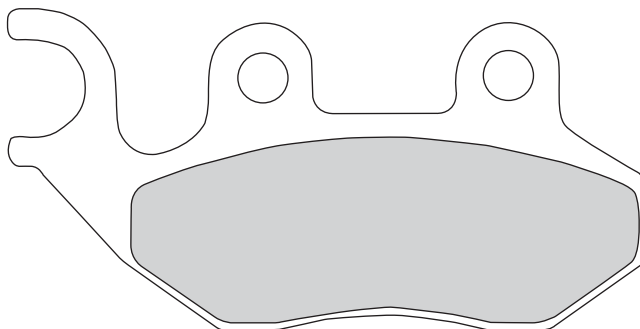

CAGIVA	CC	MY	A	P
PASSING	50	95		•
STELLA	50	97		•
PASSING	125	94		•
PGO	CC	MY	A	P
PMS	50	99		•

T REX	50	99		•	
MY BUBU	100	02		•	
PMS	110	99		•	
T REX	110	99		•	
CHARGE	125	02		•	
MY BUBU	125	02		•	

T REX 2T	125	99		•	
T REX 4T	150	00		•	
TR 3	150	02		•	
SYM	CC	MY	A	P	
JET	50	99		•	
JUNGLE	50	99		•	

PASTIGLIE FRENO BRAKE PADS

P.188

SYM	CC	MY	A	P
MUSK L.C.	50	99	•	

RED DEVIL	50	99	•	
ATTILA	125	99	•	
MEGALO	125	02	•	
SHARK	125	99	•	

SHARK 125	125	00	•	
SUPER DUKE	125	99	•	

P.190



94.2



33.7



7.5

SINTERIZZATA
SINTERED
P.190ACX

ORGANICA STRADALE
ROAD ORGANIC
P.190ASX

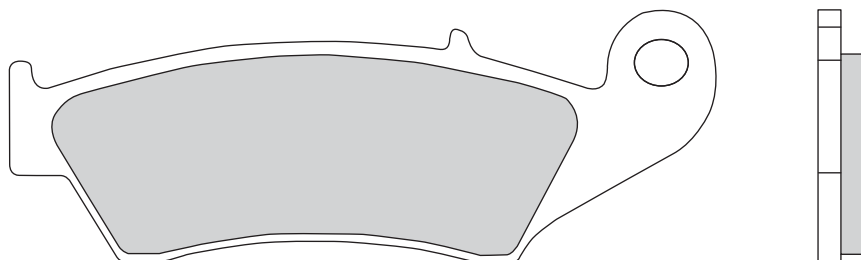

APRILIA	CC	MY	A	P
RXV ENDURO	450	06	•	
RXV ENDURO	550	06	•	
BETA	CC	MY	A	P
RR ENDURO	250	05	07	•
RR ENDURO	400	05	07	•
RR ENDURO	450	05	07	•
RR ENDURO	525	05	07	•
GAS GAS	CC	MY	A	P
EC (NISSIN)	125	00	07	•
MC	125	05		•
MX	125	01	04	•
EC (NISSIN)	200	00	07	•
EC (NISSIN)	250	00	07	•
MC	250	00		•
MX	250	01	04	•
EC (NISSIN)	300	00	07	•
EC FSE	400	01		•
FSE	450	05	06	•
FSE	500	05	06	•
HM	CC	MY	A	P
CR MOTARD	125	04	06	•
CRE R ENDURO	125	02	03	•
CRE R ENDURO	125	04	07	•
CRE R SUPERMOTARD	125	02	03	•
CRE	250	97	01	•
CRE	250	02		•
CRE F ENDURO	250	04		•
CRE R ENDURO	250	02	07	•
CRE R SUPERMOTARD	250	02	03	•
CRF MOTARD	250	04	06	•
CRE F ENDURO	450	02		•
CRF MOTARD	450	04		•
CRE F X	490	07		•
HONDA	CC	MY	A	P
CR RH-J-K-L-M-N-P-R-S-T-X	125	94	00	•
XLR RW	125	98	01	•
XR L3/L4/L5	125	03		•
CR RR-RX	250	94	01	•

CR RR-RX	250	02	07	•	
CRF R	250	04		•	
CRF X	250	04	09	•	
XR RG-H-J-K-L-M-N-P-R-S	250	86	87	•	
XR RT-RX	250	96	02	•	
XR RT-RX	250	03		•	
NX 4 FALCON	400	03		•	
XR R	400	96	03	•	
CRF R	450	02		•	
CRF X	450	05	09	•	
CR RL-RM-RN-RP-RR-RS-RT	500	94	00	•	
XL TRANSALP-VH-VV	600	97	00	•	
XR RE-RH	600	94	99	•	
XL TRANSALP-VH-VV	650	00	05	•	
XR RY/R1-R7	650	00	07	•	
XRV-L V AFRICA TWIN	750	90	93	•	

KAWASAKI	CC	MY	A	P
KX K1-K5/L1-L4	125	95	03	•
KX M1-M2-M3	125	04		•
KDX H1-H5	200	95	99	•
KDX R A1-A12	220	97	05	•
KLX D1-D2	250	93	95	•
KLX F1-F4	250	94	97	•
KLX G1	250	94	99	•
KLX H6	250	05		•
KLX J1-J6	250	98	03	•
KX F	250	04	07	•
KX K1	250	94		•
KX K2-K5/L1-L5	250	95	02	•
KX M1-M2/R1	250	03		•
KLF B1-B7 BAYOU LEFT	400	93	99	•
KX F	450	06		•
KX E6-E7	500	94	95	•
KX E8-E16	500	96	04	•
KLX C1-C3	650	93	97	•

SUZUKI	CC	MY	A	P
RM K2/K3/K4/K5/K6/K7	125	02	07	•
RM T/V/W	125	96	98	•
RM X/Y/K1	125	99	01	•

DR R	250	95	00	•	
DR R DEJBEL	250	96	98	•	
DR Z K1-K5	250	01	05	•	
RM T/V/W/X/Y/K1-K2	250	96	02	•	
RM Z K4-K5	250	04		•	
RM-Z K3-K4-K5-K6-K7	250	03	07	•	
RMX ST/SV/SW/SX	250	96	99	•	
RMX T/V/W	250	96	98	•	
SBK2	250	02		•	
DR Z	400	00	07	•	
DR Z SMK5/SMK6/SMK7	400	05	07	•	
RM Z K5/K6/K7/K8	450	05	07	•	
RM Z K8	450	08		•	
DR SET	650	96		•	

YAMAHA	CC	MY	A	P
YZ K/L/M/N/P	125	98	02	•
YZ R/S/T/V/W	125	03	07	•
WR FN/FP/FR/FS/FT	250	00	02	•
WR FN/FP/FR/FS/FT/FV/FW	250	03	07	•
WR ZK	250	98		•
YZ FN/FP/FR/FS/FT	250	01	02	•
YZ K/L/M 2T	250	98	03	•
YZ R/S/T/V/W	250	03	07	•
WR FL/FM/FN	400	99	01	•
YZ FK	400	98		•
YZ FL	400	99		•
WR FN/FP	426	01	02	•
YZ FM	426	00		•
YZ FN/FP	426	01	02	•
WR FR/FS	450	03	05	•
WR FT	450	06		•
WR FT	450	07		•
YZ FR/FS	450	03	05	•
YZ FT	450	06		•
YZ FT	450	07		•

PASTIGLIE FRENO BRAKE PADS

► **P.192**



SINTERIZZATA
SINTERED
P.192ACX

ORGANICA STRADALE
ROAD ORGANIC
P.192ASX

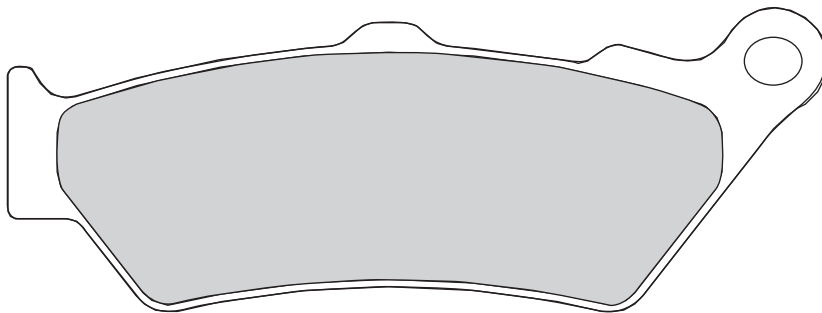

APRILIA	CC	MY	A	P
MOTO 6.5	650	95	•	
PEGASO	650	97 00	•	
PEGASO	650	06	•	
PEGASO I.E.	650	01 04	•	
CAPONORD RAID	1000	03	•	
ETV-CAPONORD/RAID	1000	01 02	•	
PEGASO	1000	01	•	
BMW	CC	MY	A	P
C1	125	99 03	•	
C1	200	01 03	•	
F 650	650	93 00	•	
F 650 CS / SCARVER	650	00 06	•	
F 650 GS	650	93 07	•	
F 650 GS DAKAR	650	93 07	•	
F 650 ST	650	93 00	•	
G 650 XCHALLENGE	650	07	•	
G 650 XCOUNTRY	650	07 09	•	
H2 ENDURO	1150	05	•	
HS SM	1150	06	•	
CAGIVA	CC	MY	A	P
CANYON	900	97	•	

DUCATI	CC	MY	A	P
MULTISTRADA	620	05	•	
695 MONSTER	695	07	•	
S2 R	803	05	•	
S2 R DARK	803	05	•	
GT 1000 SPORT	992	06	•	
PAUL SMART LIMITED	992	06	•	
SPORT CLASSIC	992	06	•	
SPORT	1000	06	•	
HONDA	CC	MY	A	P
CB V/W/SW/X/SX/Y/SY	500	97 03	•	
FX VIGOR	650	99 03	•	
NT DEAUVILLE	650	98 01	•	
NX DOMINATOR-T-K-L-M-N	650	87	•	
SLR	650	97 98	•	
KTM	CC	MY	A	P
ADVENTURE S	950	04 06	•	
ADVENTURE S	990	06	•	
MOTO GUZZI	CC	MY	A	P
BREVA V	1100	05	•	
GRISO	1100	05	•	
SPORT	1200	07	•	

TRIUMPH	CC	MY	A	P
ROCKET III	2300	04	•	
VICTORY	CC	MY	A	P
8-BALL	1500	05	•	
ARLEN NESS	1500	04	•	
HAMMER	1500	05	•	
HAMMER S	1500	07	•	
KING PIN	1500	04	•	
KING PIN TOUR	1500	07	•	
TOURING CRUISER	1500	03	•	
V92C CRUISER	1500	98 02	•	
V92C DELUXE	1500	01 02	•	
V92SC SPORT CRUISER	1500	00 02	•	
VEGAS	1500	03	•	
VEGAS JACKPOT	1500	06	•	
YAMAHA	CC	MY	A	P
DT X	125	05	•	
XT R	660	04 05	•	

► **P.193**



SINTERIZZATA
SINTERED
P.193ACX

ORGANICA STRADALE
ROAD ORGANIC
P.193ASX

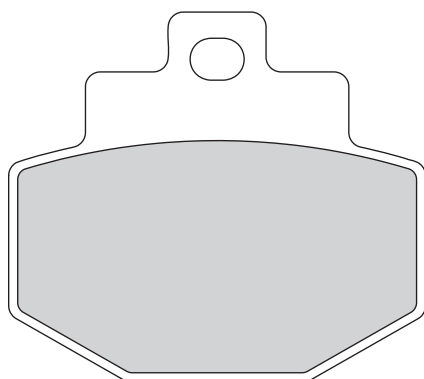

BENELLI	CC	MY	A	P
ADIVA	125	01 04	•	
ADIVA	150	00	•	
GILERA	CC	MY	A	P
DNA L.C. (G)	50	00 02	•	
DNA L.C. (H)	50	00	•	
DNA 4T (G)	125	01 02	•	
DNA 4T (H)	125	01 03	•	
RUNNER VX (G)	125	01	•	

RUNNER VX (H)	125	01	•	
DNA 4T (G)	180	01	•	
DNA 4T (H)	180	01	•	
RUNNER VXR 4T (G)	180	01	•	
RUNNER VXR 4T (H)	180	01	•	
PIAGGIO	CC	MY	A	P
HEXAGON GTX (G)	125	00	•	
HEXAGON GTX (H)	125	00	•	
SUPERHEXAGON GTX (H)	125	01	•	

HEXAGON GTX (G)	250	00	•	
VESPA	CC	MY	A	P
VESPA GRANTURISMO L (H)	125	03	•	
VESPA GT60	250	06	•	
VESPA GTS	250	05 07	•	
VESPA GTV	250	07	•	
GTS SUPER	300	08	•	

PASTIGLIE FRENO BRAKE PADS

► P.194



SINTERIZZATA
SINTERED
P.194ACX

ORGANICA STRADALE
ROAD ORGANIC
P.194ASX

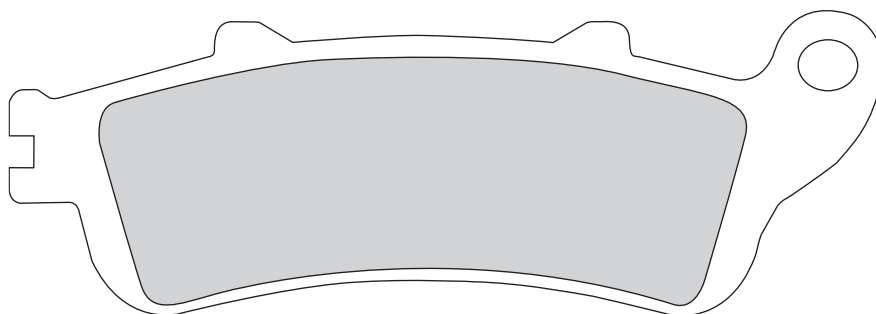

HONDA	CC	MY	A	P
PANTHEON	125	98 99	•	
PANTHEON	125	00 02	•	
PANTHEON	125	03	•	
PANTHEON	150	98 02	•	
PANTHEON	150	03	•	
FORESIGHT	250	97 00	•	

FORESIGHT	250	01	•	
JAZZ	250	01	•	
REFLEX	250	01 04	•	
SILVER WING	600	01	•	
SILVER WING ABS	600	01	•	
NTV V	650	02		•
VFR A2/A3	800	03	•	•

VARADERO	1000	99 00		•
PEUGEOT	CC	MY	A	P
LOOXOR	125	03	•	
SV	250	03	•	
SV	250	01 02	•	

► P.195



ORGANICA STRADALE
ROAD ORGANIC
P.195ASX

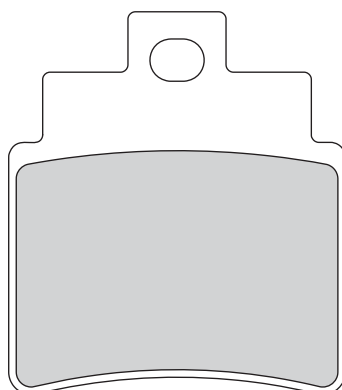

KYMCO	CC	MY	A	P
GRAND DINK	250	02	•	
SYM	CC	MY	A	P
VOYAGER	125	05	•	

VOYAGER	150	05	•	
---------	-----	----	---	--

PASTIGLIE FRENO BRAKE PADS

► P.196



ORGANICA STRADALE
ROAD ORGANIC
P.196ASX

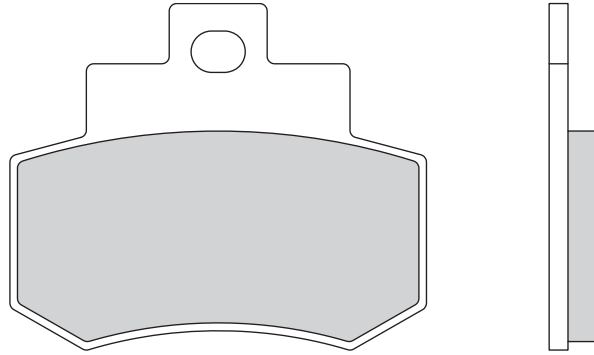

KYMCO	CC	MY	A	P
GRAND DINK	250	02		•

► P.197



SINTERIZZATA
SINTERED
P.197ACX

ORGANICA STRADALE
ROAD ORGANIC
P.197ASX

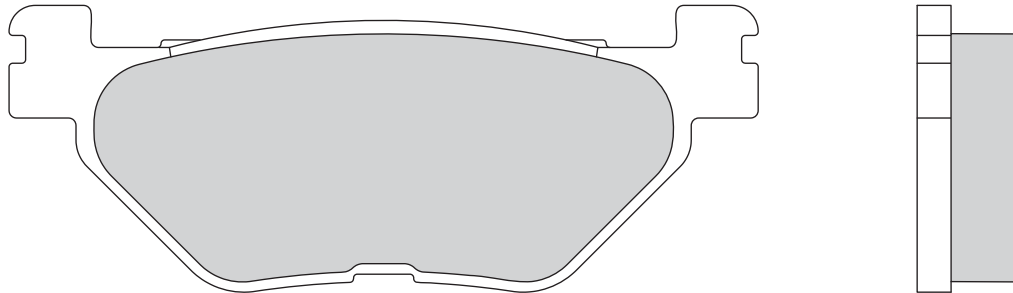

YAMAHA	CC	MY	A	P
T MAX	500	01 03		•
T MAX CUP	500	03		•
T MAX SV	500	11		•

XP T MAX	530	12		•
TDM AT/AV/AW (ABS)	900	05 07		•
TDM P/R/S/T/V	900	02 06		•
FJR N/P	1300	01 02		•

FJR R/AR/S/AS/AT	1300	03 05		•
XV PCR ROAD STAR WARRIOR 1700		03 05		•

► P.198



ORGANICA TRIAL
TRIAL SEMI-METALLIC
P.198ATX

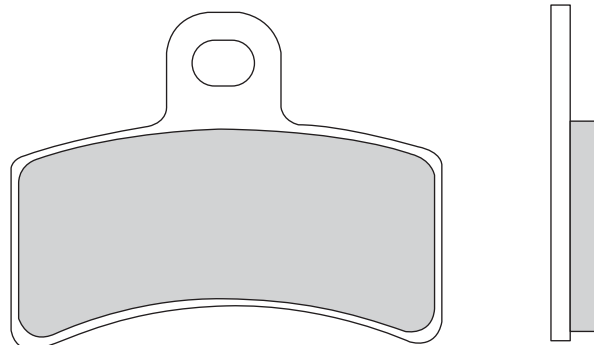

BETA	CC	MY	A	P
RR ENDURO ALU	50	03		•
RR MOTARD ALU	50	03		•
GAS GAS	CC	MY	A	P
CROSS MC	50	06		•
EC BOY	50	01 04		•
EC ROOKIE	50	01 04		•
SM	50	05		•

SM ROOKIE	50	01 04		•
TXT BOY	50	01 03		•
TXT ROOKIE	50	03		•
PAMPERA	125	03 04		•
TXT	125	00 03		•
TXT	200	00 03		•
TXT	250	00 03		•
TXT	270	99 00		•

PAMPERA	280	04		•
TXT	280	00 03		•
TXT BOY	280	01		•
TXT	321	00 03		•

PASTIGLIE FRENO BRAKE PADS

► P.199



50.0



43.8



6.0

ORGANICA TRIAL
TRIAL SEMI-METALLIC
P.199ATX

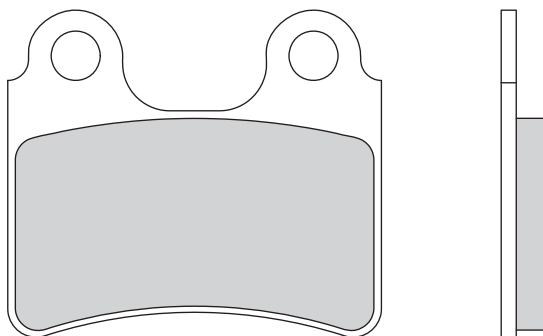

BETA	CC	MY	A	P
RR ENDURO ALU	50	03	•	
RR MOTARD ALU	50	03	•	
EVO	80	09	•	
EVO	125	09	•	
REV 3	200	00 05	•	•
REV 3	200	06	•	
EVO	250	09	•	
REV 3	250	00 04	•	•
REV 3	250	05 07	•	
REV 3	270	00 04	•	•

REV 3	270	05 07	•	
EVO	300	09	•	
GAS GAS	CC	MY	A	P
EC BOY L.C.	50	05	•	
TXT ROOKIE	80	04 05	•	
TXT PRO	125	04	•	
TXT PRO	200	04	•	
TXT PRO	250	04	•	
TXT PRO	280	04	•	
TXT PRO	300	04	•	

MONTESA	CC	MY	A	P
COTA R	315	01	•	
SCORPA	CC	MY	A	P
SY F TRIAL	125	03 06	•	
SY	250	00 06	•	
SY F	250	06	•	
SY LONG RIDE	250	04 05	•	
SHERCO	CC	MY	A	P
2.5	250	02	•	
3.2	320	05	•	

► P.200



36.0



39.0



6.0

ORGANICA TRIAL
TRIAL SEMI-METALLIC
P.200ATX

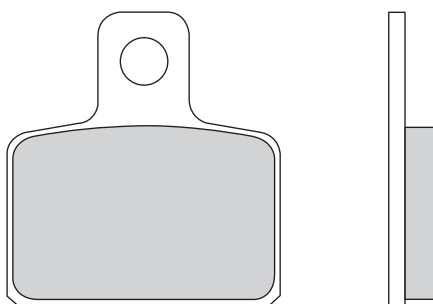

BETA	CC	MY	A	P
PRO RACE	50	05	•	
GAS GAS	CC	MY	A	P
CROSS MC	50	06	•	
EC BOY	50	05	•	
EC BOY L.C.	50	05	•	
MC	65	05	•	
TXT ROOKIE	80	04 05	•	
TXT PRO	125	04	•	
TXT PRO	200	04	•	

TXT PRO	250	04	•	
TXT PRO	280	04	•	
TXT PRO	300	04	•	
HUSQVARNA	CC	MY	A	P
TE	100	05	•	
MONTESA	CC	MY	A	P
COTA R	315	01	•	
SCORPA	CC	MY	A	P
SY F TRIAL	125	03 06	•	
TY-S F	125	06	•	

TY-S F	175	06	•	
SY	250	00 06	•	
SY F	250	06	•	
SY LONG RIDE	250	04 05	•	
SHERCO	CC	MY	A	P
2.5	250	02	•	
3.2	320	05	•	

PASTIGLIE FRENO BRAKE PADS

► P.201



ORGANICA STRADALE
ROAD ORGANIC
P.201ASX

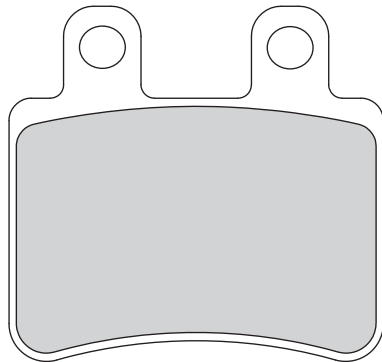

DERBI	CC	MY	A	P
BOULERVARD 4T	125	03	•	
BOULERVARD 4T	150	03 05	•	
BOULERVARD 4T	200	05	•	
HM	CC	MY	A	P
CRE BAJA	50	03 09		•
DERAPAGE	50	03 06		•
SIX	50	03 06		•
ITALJET	CC	MY	A	P
JET-SET	50	03	•	

MILLENNIUM 2T	100	02		•	
JET-SET	125	02		•	
JET-SET	150	02		•	
MILLENNIUM 4T	150	02		•	
PEUGEOT	CC	MY	A	P	
ELISTAR	50	02 03		•	
ELISTAR AVANTAGE 2	50	04		•	
ELISEO	125	03		•	
ELISTAR	125	02 03		•	
JET FORCE	125	03		•	

ELISEO	150	03			•
SCORPA	CC	MY	A	P	
T-RIDE F	250	09			•
YAMAHA	CC	MY	A	P	
XT R	125	05 07		•	•
XT X	125	05 07			•

► P.202



SINTERIZZATA
SINTERED
P.202ACX

ORGANICA STRADALE
ROAD ORGANIC
P.202ASX

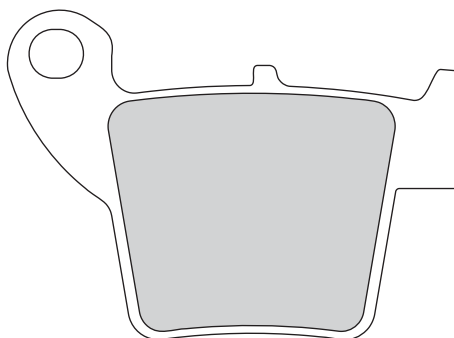

HM	CC	MY	A	P
CR MOTARD	125	04 06		•
CRE R ENDURO	125	02 03		•
CRE R ENDURO	125	04 07		•
CRE R SUPERMOTARD	125	02 03		•
CRE	250	02		•
CRE F ENDURO	250	04		•
CRE R ENDURO	250	02 07		•
CRE R SUPERMOTARD	250	02 03		•

CRF MOTARD	250	04 06		•
CRE F ENDURO	450	02		•
CRF MOTARD	450	04		•
CRM F R SUPERMOTO	450	07		•
CRM F X SUPERMOTO	450	07		•
CRE F X	490	07		•
CRM F X SUPERMOTO	490	07		•
HONDA	CC	MY	A	P
CR RH-J-K-L-M-N-P-R-S-T-X	125	94 00		•

CRF R	150	07 09		•
CR RR-RX	250	02 07		•
CRF R	250	04		•
CRF X	250	04 09		•
XR RT-RX	250	03		•
CRF R	450	02		•
CRF X	450	05 09		•

PASTIGLIE FRENO BRAKE PADS

► P.203



63.9



42.0



9.5

SINTERIZZATA
SINTERED
P.203ACX

ORGANICA STRADALE
ROAD ORGANIC
P.203ASX

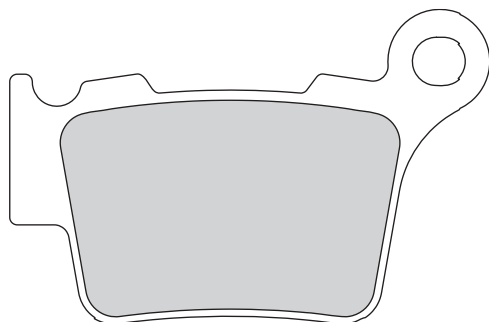

BMW	CC	MY	A	P
G 450 ENDURO	450	08		•
G 450 SMR	450	09		•
G 450 X	450	09		•
HUSABERG	CC	MY	A	P
FE	390	10		•
FE E	450	09		•
FX	450	10		•
FE E	570	09		•
FS	570	10		•
HUSQVARNA	CC	MY	A	P
CR	125	05		•
WR	125	06		•
CR	250	05		•
TC	250	04		•
TE	250	06		•
TXC CROSS COUNTRY	250	08		•
WR	250	06		•
WR	300	09		•
XC-W	300	10		•
TE	310	09		•

XC-W	400	10		•
TE	410	06		•
SM R	450	07		•
SM RR	450	07		•
TC	450	05		•
TE	450	05		•
TC	510	05		•
TE	510	06		•
KTM	CC	MY	A	P
EXC	125	03		•
EXC	125	04	06	•
EXC	125	07		•
SX	125	04		•
EXC	200	03		•
EXC	200	04	06	•
EXC	200	07		•
SX	200	03		•
SX	200	04		•
EXC	250	03		•
MX	250	03		•
SX	250	03		•

SX-F	250	05	08	•
XC-F	250	06	08	•
XC-F-W	250	06	08	•
EXC	300	03		•
EXC RACING	400	04	05	•
EXC RACING	400	06		•
EXC RACING	450	04	05	•
EXC RACING	450	06		•
SX RACING	450	04	05	•
SX RACING	450	06		•
EXC RACING	525	04	05	•
EXC RACING	525	06		•
SMR	525	05		•
SX RACING	525	06		•
SMR	560	06		•
EXC	625	03		•
YAMAHA	CC	MY	A	P
YZ FT	450	07		•

PASTIGLIE FRENO BRAKE PADS

► P.204



96.9
76.8



41.2
41.2



9.0
9.0

SINTERIZZATA
SINTERED
P.204ACX

ORGANICA STRADALE
ROAD ORGANIC
P.204ASX

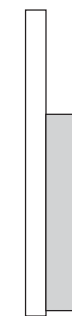
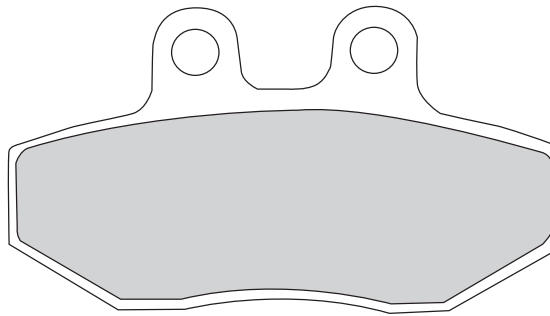
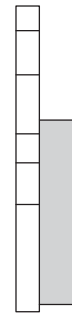
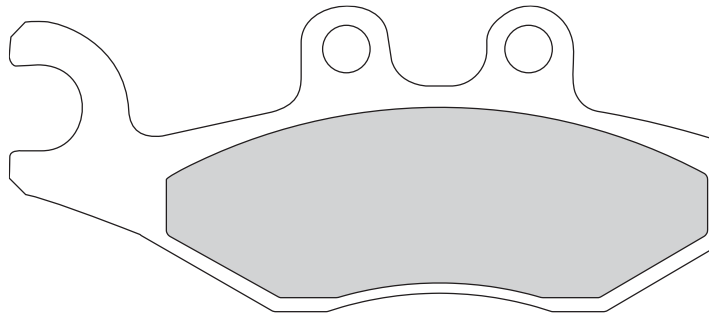

GILERA	CC	MY	A	P
DNA L.C. (H)	50	00	•	
DNA 4T (H)	125	01 03	•	
NEXUS	125	07	•	•
RUNNER FX (H)	125	97 99	•	
RUNNER FX (H)	125	00	•	
RUNNER VX (H)	125	01	•	
DNA 4T (H)	180	01	•	
RUNNER FXR (H)	180	00	•	
RUNNER VXR 4T (H)	180	01	•	
NEXUS I.E.	250	06	•	•
NEXUS I.E.	500	06	•	•
MALAGUTI	CC	MY	A	P
CENTRO IE SL	125	09 10	•	
CENTRO IE SL	160	09 10	•	
PEUGEOT	CC	MY	A	P
GEOPOLIS	125	06	•	•
GEOPOLIS PREMIUM	250	06	•	•

PIAGGIO	CC	MY	A	P
FLY (E.U.)	50	05	•	
FLY	100	07	•	
BEVERLY	125	07	•	
BEVERLY B 4T (H)	125	02 06	•	•
BEVERLY S	125	07	•	•
HEXAGON GTX (H)	125	00	•	
HEXAGON LX (H)	125	98 99	•	
SKIPPER LX 2T (H)	125	98 99	•	
SKIPPER ST 4T (H)	125	00	•	
SUPERHEXAGON GTX (H)	125	01	•	
X 8 4T	125	04 05	•	
X 8 4T	125	05 06	•	
X 8 I.E.	125	07	•	
FLY 4T	150	05	•	
HEXAGON LXT (H)	180	98 99	•	
X 8	180	07	•	
LIBERTY 4T	200	05	•	•

X 8 4T	200	04 05	•	
BEVERLY 4T	250	04	•	•
BEVERLY I.E.	250	07	•	•
BEVERLY S I.E.	250	07	•	•
HEXAGON GT 4T (H)	250	98 99	•	
HEXAGON GTX (H)	250	00	•	
X 9	250	05 06	•	
X 8 I.E.	400	07	•	
VESPA	CC	MY	A	P
VESPA ET4 (H)	50	01	•	
VESPA GT60	250	06	•	
VESPA GTE	250	05	•	
VESPA GTS	250	05 07	•	
VESPA GTV	250	07	•	
GTS SUPER	300	08	•	

► P.205



66.9



36.0



10.9

SINTERIZZATA
SINTERED
P.205ACX

ORGANICA STRADALE
ROAD ORGANIC
P.205ASX

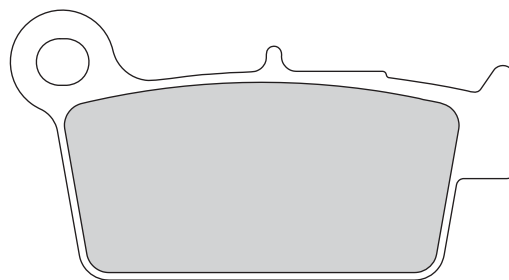

APRILIA	CC	MY	A	P
SXV SUPERMOTARD	450	06		•
RXV ENDURO	550	06		•
SXV SUPERMOTARD	550	06		•
BETA	CC	MY	A	P
RR	125	06		•

ALP	200	00		•
RR ENDURO	250	05 07		•
M4 MOTARD	350	07		•
MOTARD 4.0	400	04		•
RR ENDURO	400	05 07		•
RR ENDURO	450	05 07		•

RR ENDURO	525	05 07		•
KAWASAKI	CC	MY	A	P
KX F	450	06		•
MOTO TM	CC	MY	A	P
MX	85	05		•
ENDURO	125	04		•

► P.205

MOTO TM	CC	MY	A	P
MX	125	05		•
ENDURO 4T	250	04		•
EN F ES	450	05		•
MX F	450	05		•
SMM F BLACK DREAM ES	450	05		•
SMR	450	06		•
SMR F ES	450	05		•
SMX	450	05	06	•

EN F ES	530	05		•
MX F	530	05		•
SMR	530	06		•
SMX F	660	04		•
SHERCO	CC	MY	A	P
4.5 ENDURO/SUPERMOTARD	450	04	05	•
5.1 ENDURO	510	06		•
SUZUKI	CC	MY	A	P
RM Z K4-K5	250	04		•
RM-Z K3-K4-K5-K6-K7	250	03	07	•
RM Z K5/K6/K7/K8	450	05	07	•

RM Z K8	450	08		•
YAMAHA	CC	MY	A	P
YZ R/S/T/V/W	125	03	07	•
WR FN/FP/FR/FS/FT/FV/FW	250	03	07	•
YZ FN/FP/FR/FS/FT	250	01	02	•
YZ R/S/T/V/W	250	03	07	•
WR FR/FS	450	03	05	•
WR FT	450	06		•
YZ FT	450	06		•

► P.206



81.8



42.5



9.3

SINTERIZZATA
SINTERED
P.206ACX

ORGANICA STRADALE
ROAD ORGANIC
P.206ASX

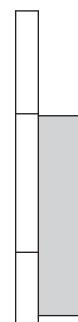
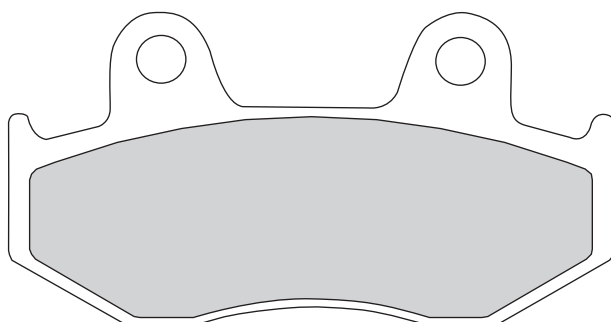

HONDA	CC	MY	A	P
@	125	00		•
DYLAN	125	01		•
PS I.	125	06		•

SH	125	01	08	•
SH I.	125	05	08	•
@	150	00		•
DYLAN	150	01		•

PS I.	150	06		•
SH	150	01	08	•
SH I.	150	05		•

► P.207



80.9



41.7



8.3

ORGANICA STRADALE
ROAD ORGANIC
P.207ASX

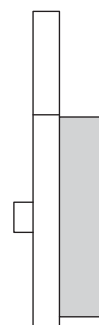
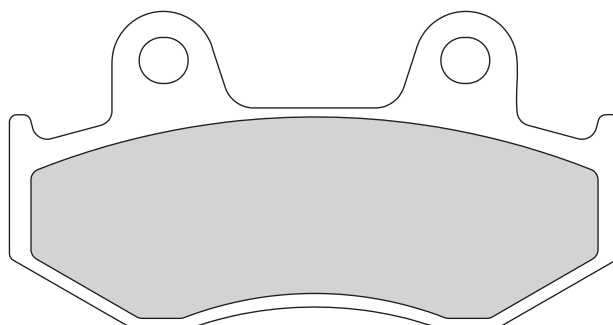

SUZUKI	CC	MY	A	P
AN BURGMAN	250	04	06	•
AN BURGMAN	250	07		•
AN BURGMAN BUSINESS	250	01	02	•
AN BURGMAN	400	04	06	•

PASTIGLIE FRENO BRAKE PADS

► P.208



ORGANICA STRADALE
ROAD ORGANIC
P.208ASX

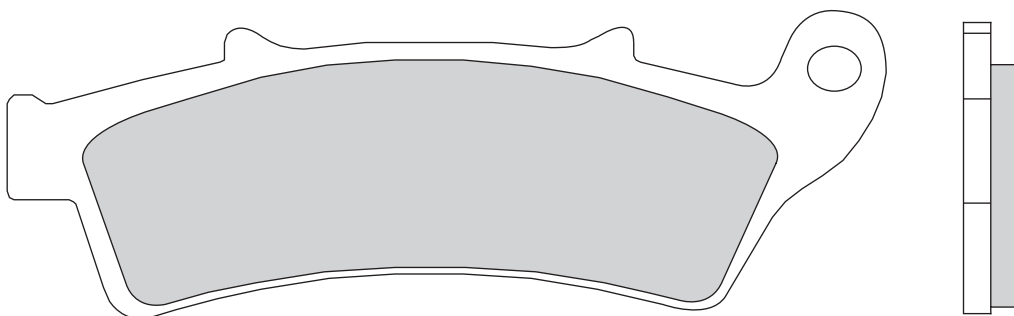

APRILIA	CC	MY	A	P
ATLANTIC	125	03 06	•	
ATLANTIC	125	07	•	
SCARABEO	125	07	•	
SCARABEO GT	125	04 06	•	
SCARABEO GT	150	04 06	•	
ATLANTIC	200	03 04	•	
ATLANTIC	200	05	•	
SCARABEO	200	07	•	

ATLANTIC	250	03 04	•	
ATLANTIC	250	05 06	•	
ATLANTIC I.E.	250	07	•	
SCARABEO	250	06	•	
SCARABEO I.E.	250	07	•	
SCARABEO S	300	09	•	
ATLANTIC SPRINT	400	07	•	
MALAGUTI	CC	MY	A	P
MADISON	250	99 00	•	

MADISON	250	01 04	•	
MADISON RS	250	05	•	
MADISON	400	02 04	•	
MADISON K	400	05	•	
PEUGEOT	CC	MY	A	P
LOOXOR	100	02	•	
LOOXOR	150	03	•	

► P.209

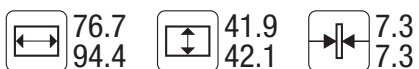

ORGANICA STRADALE
ROAD ORGANIC
P.209ASX

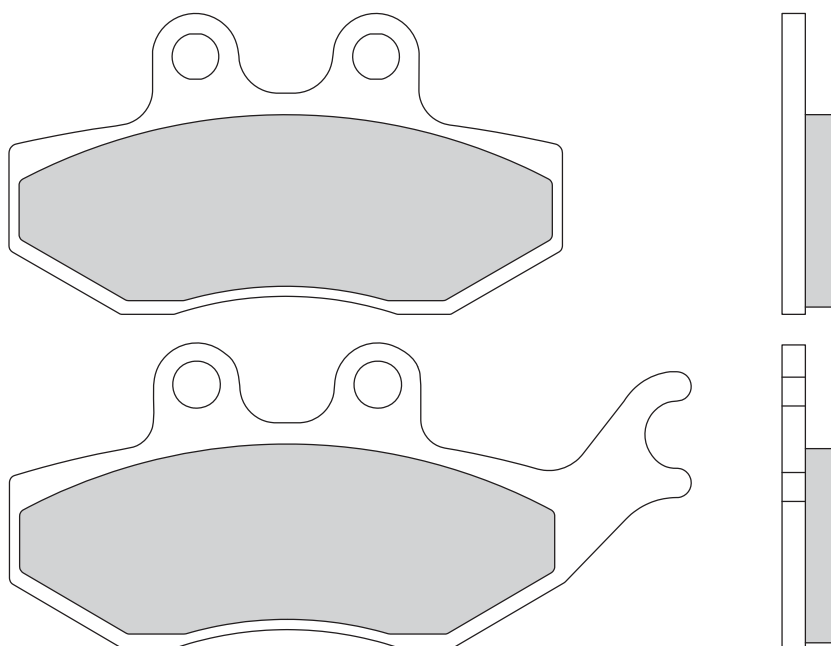

ITALJET	CC	MY	A	P
JUPITER	250	02		•
RIEJU	CC	MY	A	P
RS2 MATRIX	50	03	•	

PASTIGLIE FRENO BRAKE PADS

► P.210



ORGANICA STRADALE
ROAD ORGANIC
P.210ASX

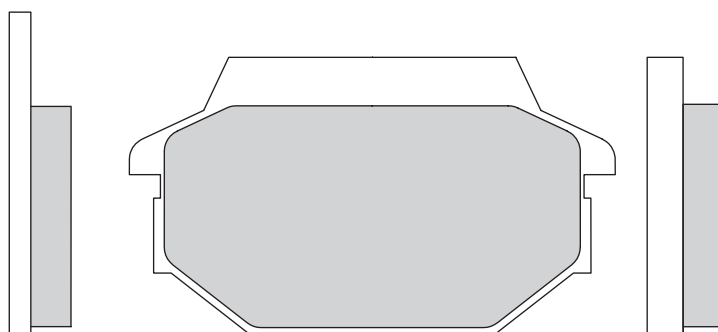
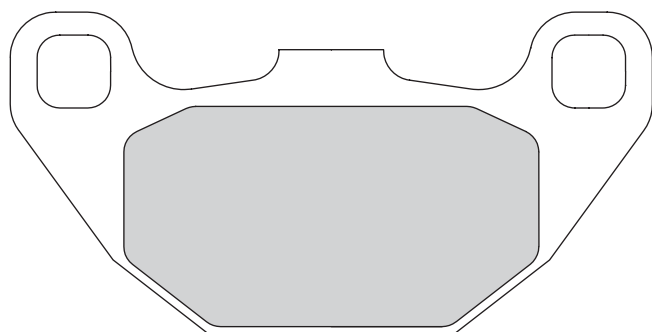

KAWASAKI	CC	MY	A	P
KXF	50	07 09		•
KXF	90	07		•
KYMCO	CC	MY	A	P
AGILITY	50	05	•	
LIKE 2T	50	09	•	
LIKE 4T	50	09	•	
PEOPLE S	50	05 08	•	
SUPER 8 2T	50	07	•	

SUPER 8 4T	50	07	•	
SUPER-9 L.C.	50	00		•
AGILITY	125	06	•	
PEOPLE 4T	125	00	•	
SUPER-9 L.C.	125	00		•
PEOPLE 4T	150	99	•	
SUPER 8	150	07	•	
PEOPLE 4T	200	05	•	

SYM	CC	MY	A	P
HD	125	04	•	
HS	125	04	•	
JOYRIDE	125	01		•
JOYRIDE	150	01		•
HD	200	04	•	
HS	200	04	•	
JOYRIDE	200	01		•

► P.211



SINTERIZZATA
SINTERED
P.211ACX

ORGANICA STRADALE
ROAD ORGANIC
P.211ASX

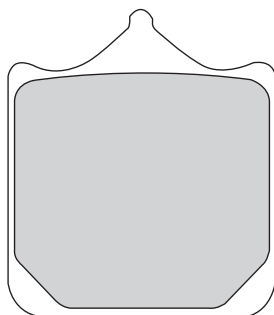

APRILIA	CC	MY	A	P
RSV FACTORY	1000	04	•	
RSV MILLE	1000	01 05	•	
RSV MILLE NERA	1000	04	•	
RSV MILLE R	1000	01 07	•	
RSV TUONO RACING	1000	04	•	
BENELLI	CC	MY	A	P
TORNADO 3	900	03 05	•	
TNT	1130	06	•	
TNT SPORT	1130	04 07	•	
TNT TITANIUM	1130	06	•	
TORNADO 3	1130	06	•	
BIMOTA	CC	MY	A	P
DB 5 MILLE	992	05	•	
SB8 K SANTAMONICA	996	06	•	
DB 5	1078	06 07	•	
DB 5 R	1078	06 07	•	
DB 6 DELIRIO	1078	07	•	
TESI III D	1078	07	•	
BMW	CC	MY	A	P
S 1000 RR	1000	10	•	
CAGIVA	CC	MY	A	P
X3-RAPTOR	1000	03 04	•	

DUCATI	CC	MY	A	P
748 R	748	01 02	•	
749	749	03 06	•	
749 DARK	749	04 06	•	
749 R	749	03 06	•	
749 S	749	03 06	•	
996 R	996	01	•	
998 MATRIX	998	04	•	
998 R	998	02	•	
998 S	998	02 06	•	
S4 RS MONSTER	998	05	•	
999	999	03 06	•	
999 R	999	03 06	•	
999 S	999	03 04	•	
HUSQVARNA	CC	MY	A	P
SM R	450	07	•	
SM RR	450	07	•	
SM R	510	05	•	
SM R	610	06	•	
SM S	610	06	•	
SM	630	09	•	
STR CRC	650	07	•	

KTM	CC	MY	A	P
DUKE	690	08	•	
DUKE R	690	10	•	
SM	690	07	•	
SMC	690	08	•	
DUKE	950	03	•	
SM	950	05 07	•	
SM R	950	05 07	•	
SMC	950	05	•	
DUKE	990	04	•	
SUPERDUKE	990	05	•	
LAVERDA	CC	MY	A	P
SFC	1000	03	•	
MONDIAL	CC	MY	A	P
EVO	1000	04	•	
PIEGA	1000	03	•	
RZ NUDA	1000	04	•	
STARFIGHTER	1000	04	•	
MOTO GUZZI	CC	MY	A	P
GRISO	1000	03	•	
FIONDA	1100	05	•	
MOTO TM	CC	MY	A	P
SMR	450	06	•	

PASTIGLIE FRENO BRAKE PADS

► P.211

MOTO TM	CC	MY	A	P
SMX	450	05 06	•	
SMR	530	06	•	
SMX F	660	04	•	

MV AGUSTA	CC	MY	A	P
BRUTALE R ITALIA	910	07	•	
BRUTALE R-S	910	05 06	•	
F4	1000	06 07	•	

SHERCO	CC	MY	A	P
4.5 IF SUPERMOTO	450	08	•	

TRIUMPH	CC	MY	A	P
SPEED TRIPLE	1050	08	•	

► P.212



55.3



52.1



7.6

ORGANICA STRADALE
ROAD ORGANIC
P.212ASX

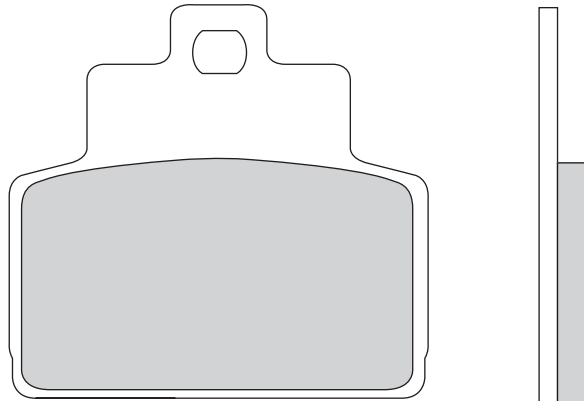

GILERA	CC	MY	A	P
FUOCO I.E.	500	07		•

PIAGGIO	CC	MY	A	P
FLY (U.S.)	50	05		•
X 8 4T	125	05 06		•
X 8 I.E.	125	07		•

X 9 EVOLUTION	125	06		•
X 8	180	07		•
MP3	250	07 08		•
X 8 I.E.	250	07		•
X 9	250	05 06		•
X 8 I.E.	400	07		•

BEVERLY	500	06		•
MP3 I.E.	500	08		•

VESPA	CC	MY	A	P
VESPA GTE	250	05		•

► P.213



100.0



38.1



12.0

SINTERIZZATA
SINTERED
P.213ACX

ORGANICA STRADALE
ROAD ORGANIC
P.213ASX

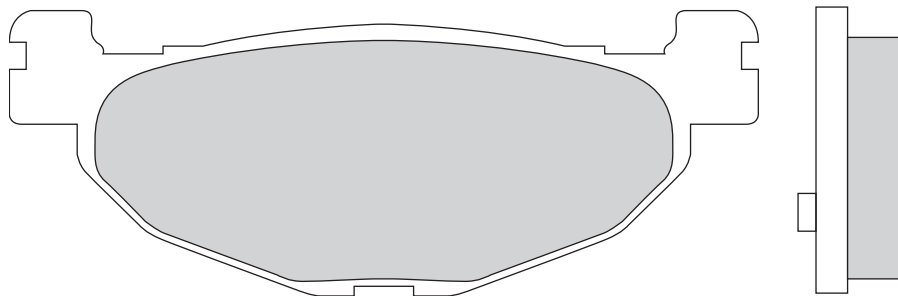

MBK	CC	MY	A	P
SKYLINER	400	04		•

YAMAHA	CC	MY	A	P
MAJESTY YP	250	04		•
MORPHOUS	250	05		•
MAJESTY S / T	400	04		•
MAJESTY T / V / W	400	05		•
T MAX	500	04 08		•
T MAX	500	09 11		•
T MAX BLACK MAX	500	06		•

PASTIGLIE FRENO BRAKE PADS

► P.214



SINTERIZZATA
SINTERED
P.214ACX

ORGANICA STRADALE
ROAD ORGANIC
P.214ASX

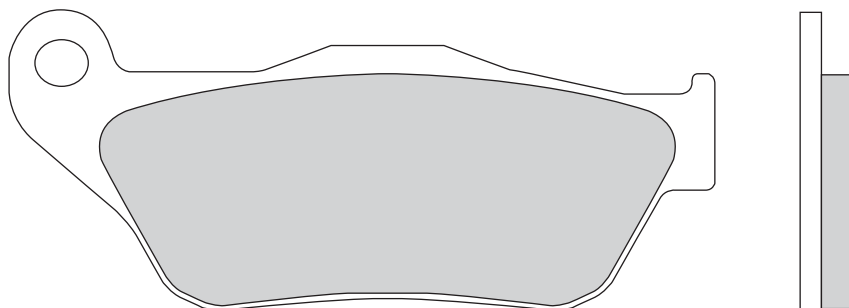

YAMAHA	CC	MY	A	P
X-MAX	125	06	•	
X-MAX	250	04 09	•	

► P.215



SINTERIZZATA
SINTERED
P.215ACX

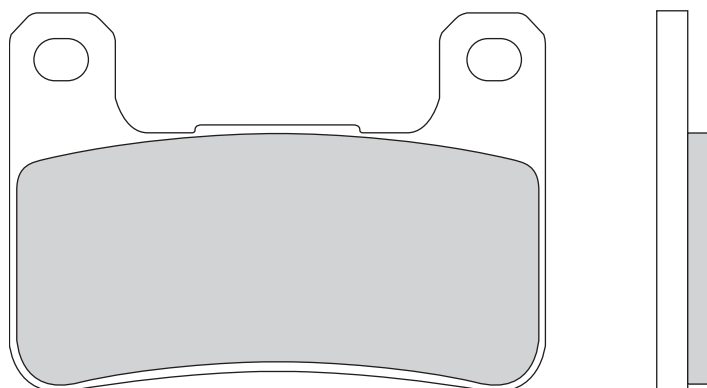

SUZUKI	CC	MY	A	P
GSX R SRAD	600	04 05	•	
GSX R SRAD	600	06	•	
GSX R K4-K5	750	04 05	•	

GSX R K6-K10	750	06 10	•	
GSX R SRAD	750	06	•	
GSX R K4	1000	04	•	
GSX R K5-K6	1000	05 06	•	

GSX R K7	1000	07	•	
VZR INTRUDER	1800	06	•	

► P.216



SINTERIZZATA
SINTERED
P.216ACX

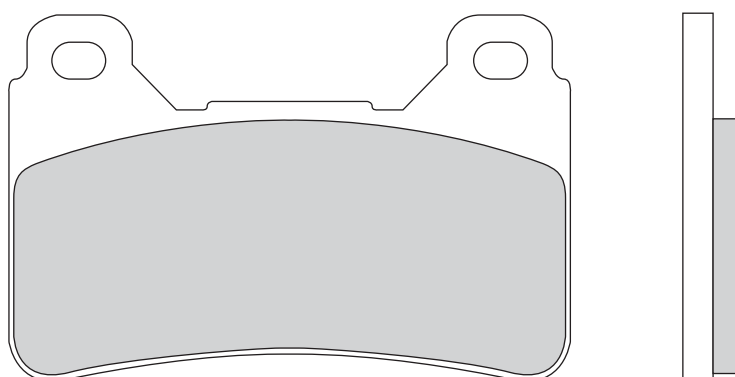

HONDA	CC	MY	A	P
CBR RR	600	05 06	•	
CBR RR	600	07	•	
CBR RR	1000	04 05	•	

CBR RR	1000	06 08	•	
--------	------	-------	---	--

PASTIGLIE FRENO BRAKE PADS

► P.218



59.8



57.2



9.5

SINTERIZZATA
SINTERED
P.218ACX

ORGANICA STRADALE
ROAD ORGANIC
P.218ASX

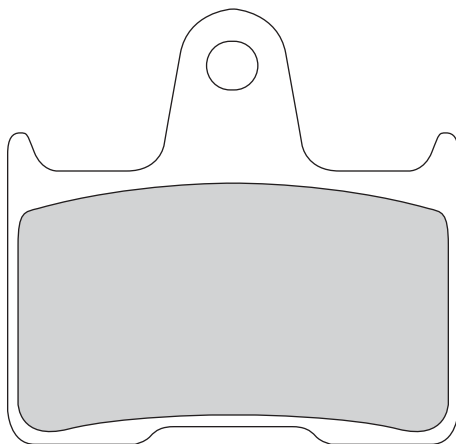

HONDA	CC	MY	A	P
CB SFX/SFY "SUPERFOUR"	400	99 03		•
CB F1	1300	01 02		•
KAWASAKI	CC	MY	A	P
GTR	1400	07		•
GTR GRAND TOUR	1400	10		•
ZG CONCOURS	1400	08		•
ZG CONCOURS ABS	1400	08		•

ZX 14R	1400	06		•
ZZR	1400	06		•
SUZUKI	CC	MY	A	P
GSX R SRAD	600	04 05		•
GSF BANDIT / S BANDIT RIGHT	650	05		•
GSX R K4-K5	750	04 05		•
GSX R SRAD	750	04 05		•
GSX R K1-K2	1000	01 02		•

GSX R K3	1000	03		•
GSX R K4	1000	04		•
GSX R K5-K6	1000	05 06		•
GS SS	1200	01		•
GSX K1-K7	1400	01 07		•

► P.219



68.2



53.1



9.8

SINTERIZZATA
SINTERED
P.219ACX

ORGANICA STRADALE
ROAD ORGANIC
P.219ASX

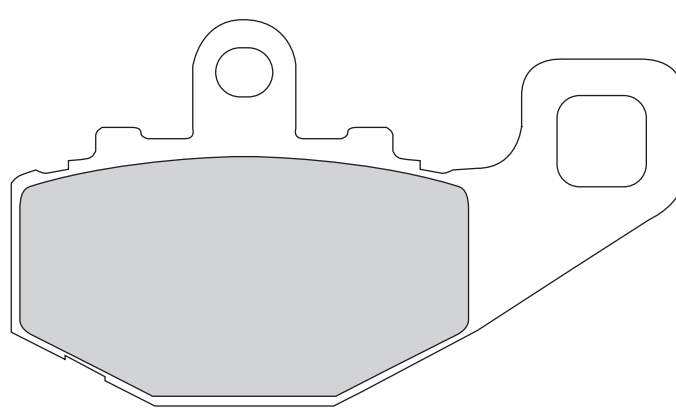
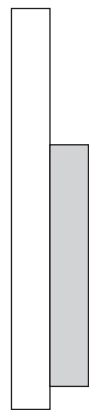
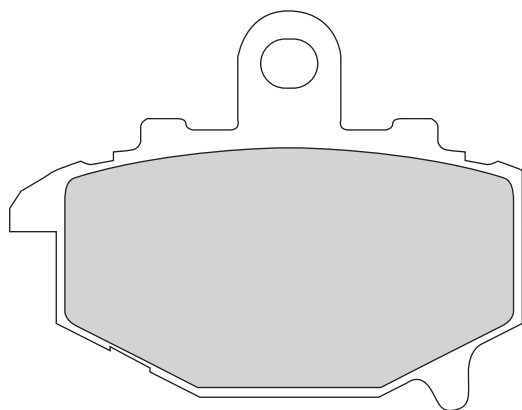

KAWASAKI	CC	MY	A	P
ZRX	400	98		•
ZR ZEPHYR	550	94 99		•
ZX 6R	600	95 97		•
ZX 6R	600	98 01		•
ZX 6RR	600	03		•
ZX 6RR	600	04 07		•

ZZR	600	93 05		•
ZX-6R	636	02 03		•
ZX-6R	636	04 06		•
ZX-6R	636	07		•
Z S P.DX	750	05		•
Z S P.SX	750	05		•
ZX 9R B3-B4	900	96 97		•

ZX 9R C1-C2/E1-E2	900	98 01		•
ZX 9R F1-F2	900	02 04		•
Z	1000	03 06		•
ZX 10R	1000	04 05		•
ZX 10R	1000	06		•

PASTIGLIE FRENO BRAKE PADS

► P.222



96.8



38.9



7.0

SINTERIZZATA
SINTERED
P.222ACX

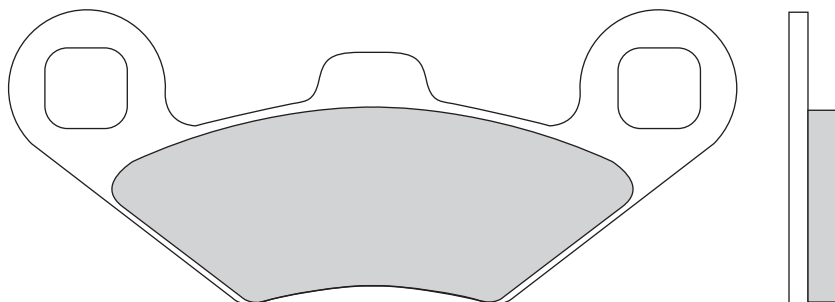

POLARIS	CC	MY	A	P
PHOENIX	200	05	•	•
L 2X4 -4X4	250	90 93	•	
TRAIL BLAZER	250	94 98	•	
TRAIL BLAZER	250	99	•	
XPLORER 4X4	250	00	•	
L 2X4 -4X4	300	94 95	•	
XPLORER 4X4	300	96 00	•	
XPRESS 2X4	300	96 00	•	
MAGNUM 2X4 - 4X4 MOUSE	325	01	•	
TRAIL BOSS	325	00 02	•	
XPEDITION	325	00 01	•	
XPEDITION 4X4	325	02	•	
ATP	330	04	•	•

MAGNUM 2X4 - 4X4	330	03	•	
SPORTSMAN 4X4 WORKER	335	99 00	•	
L 2X4 -4X4	350	90	•	
L 4X4	350	93	•	
L 2X4 -4X4	400	94 95	•	
SCRAMBLER 2X4 - 4X4	400	00	•	
SPORT	400	99 00	•	
SPORTSMAN	400	01	•	
XPLORER L 4X4	400	95 99	•	
XPLORER L 4X4	400	00	•	
MAGNUM 4X4	425	95 98	•	
XPEDITION 4X4	425	00 01	•	
XPEDITION 4X4	425	02	•	
DIESEL	455	01	•	

DIESEL 4X4 EBS	455	99	•	
ATP	500	04	•	•
BIG BOSS 6X6	500	89 99	•	
MAGNUM 2X4 - 4X4	500	02	•	
MAGNUM 4X4	500	99 01	•	
PREDATOR	500	03	•	•
RANGER	500	00	•	
SCRAMBLER 4X4	500	97	•	
SPORTSMAN 4X4	500	96	•	
SPORTSMAN 4X4	500	01	•	
XPLORER 4X4	500	97 01	•	
SPORTSMAN 4X4	700	02	•	
SPORTSMAN 4X4	800	05	•	

► P.223



89.2



46.0



9.8

SINTERIZZATA
SINTERED
P.223ACX

ORGANICA STRADALE
ROAD ORGANIC
P.223ASX

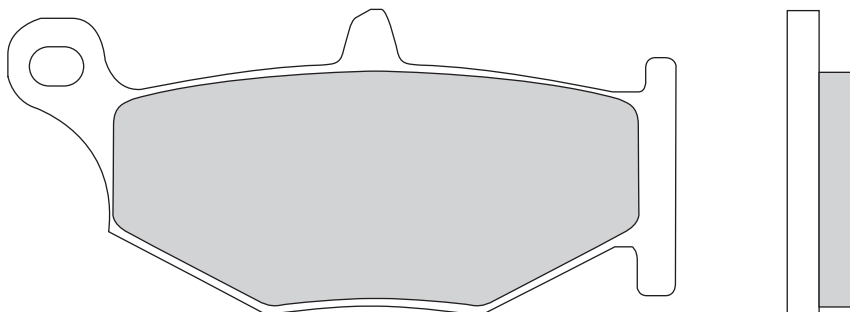

HONDA	CC	MY	A	P
CB F HORNET	600	07 09	•	

SUZUKI	CC	MY	A	P
GSR K6	400	06		•

GSR	600	06		•
GSX R SRAD	600	06		•
GSX R K6-K10	750	06 10		•
GSX R SRAD	750	06		•

GSR R K7	1000	07		•
----------	------	----	--	---

PASTIGLIE FRENO BRAKE PADS

► P.224



SINTERIZZATA
SINTERED
P.224ACX

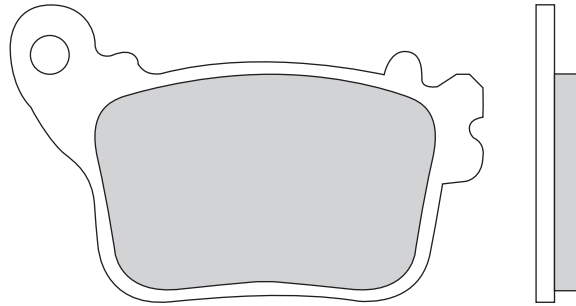

HONDA	CC	MY	A	P
CB F7 HORNET	600	00 06		•
CBR RR	600	07		•

CBR RR 1000 06 08 •

► P.225



SINTERIZZATA
SINTERED
P.225ACX

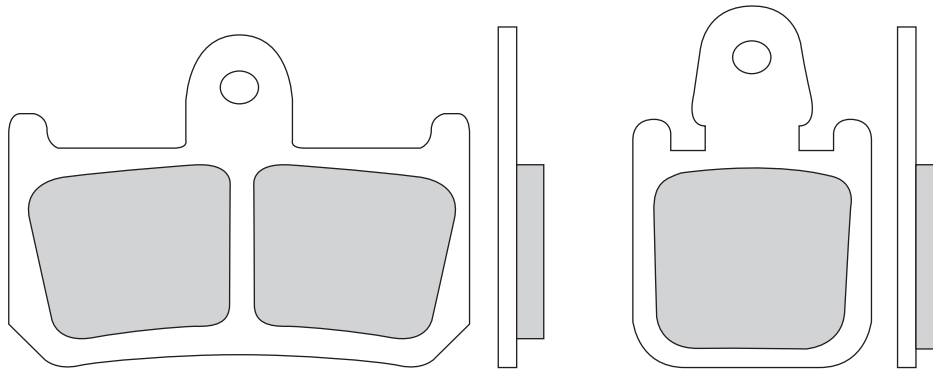

YAMAHA	CC	MY	A	P
YZF R1	1000	07		•
MT-01	1700	07		•

► P.227



SINTERIZZATA
SINTERED
P.227ACX

ORGANICA STRADALE
ROAD ORGANIC
P.227ASX

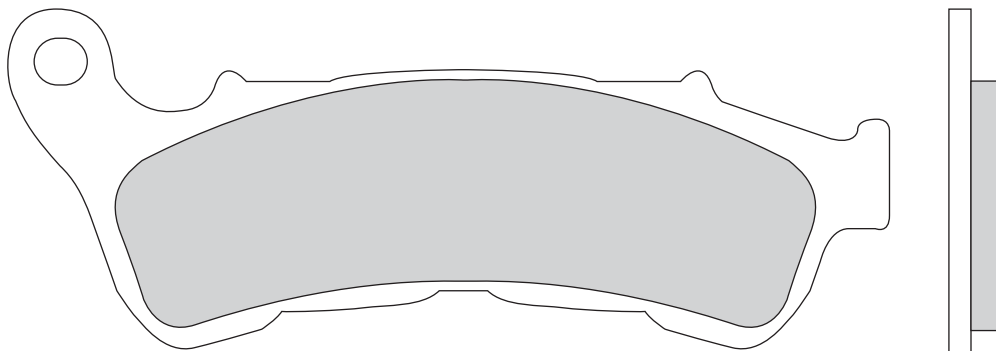

HONDA	CC	MY	A	P
SH	125	09		•
SH	150	09		•
FORZA EX	250	05 06		•
FORZA X - Z	250	05		•
REFLEX ABS	250	05 06		•
REFLEX SPORT ABS	250	05 06		•
SH I.E.	300	06		•

CBF A4/A5/A6 ABS	500	04		•
CB AF7 HORNET ABS	600	07		•
NTV V DEAUVILLE	700	06		•
VFR A6/A7	800	06 07		•
CBF F A6/A7	1000	06 07		• •
XL VA4-VA5-VA6-VA7 VARADERO	1000	04 07		•
SUZUKI	CC	MY	A	P
UH BURGMAN	125	07		•

UH BURGMAN 200 07 •

PASTIGLIE FRENO BRAKE PADS

► P.228



81.7



37.7



8.8

SINTERIZZATA
SINTERED
P.228ACX

ORGANICA STRADALE
ROAD ORGANIC
P.228ASX

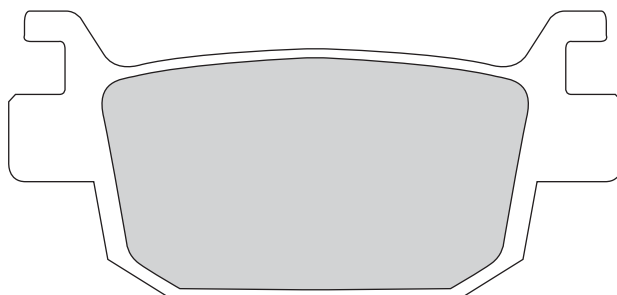

HONDA	CC	MY	A	P
SH	125	09		•
SH	150	09		•

FORZA EX	250	05	06	•
FORZA X - Z	250	05		•
REFLEX ABS	250	05	06	•

REFLEX SPORT ABS	250	05	06	•
SH I.E.	300	06		•

► P.229



102.2



42.2



7.5

SINTERIZZATA
SINTERED
P.229ACX

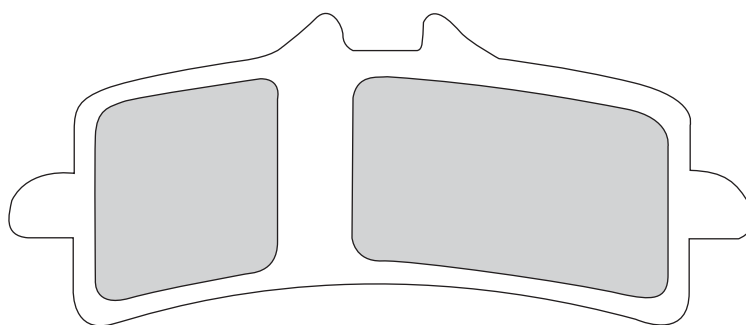

APRILIA	CC	MY	A	P
RSV4 FACTORY	1000	09	•	
RSV4 R	1000	10	•	
RSVR	1000	09	•	
DUCATI	CC	MY	A	P
848 EVO	848	11	•	
DESMOSEDICI (DD16RR)	990	08	•	
1098	1099	07	08	•
1098 R	1099	08	09	•
1098 S	1099	07	08	•
STREETFIGHTER	1099	09	•	

STREETFIGHTER S	1099	09	•	
1198	1100	09	•	
1198 S	1100	09	•	
HYPERMOTARD EVO	1100	10	•	
HYPERMOTARD S	1100	07	09	•
HYPERMOTARD EVO SP	1100	10	•	
PANIGALE S	1199	12	•	
DIAVEL	1200	11	•	
KTM	CC	MY	A	P
R RC8 R	1190	09	•	
R RC8 R TRACK	1190	09	•	

RC8	1190	08	•	
MV AGUSTA	CC	MY	A	P
F4 R	1000	07	•	
BRUTALE RR	1078	08	09	•
F4 RR	1078	08	09	•
BRUTALE RR	1090	10	•	
SUZUKI	CC	MY	A	P
GSR R	750	11	•	

PASTIGLIE FRENO BRAKE PADS

► P.230



77



56



8.6

SINTERIZZATA
SINTERED
P.230ACX

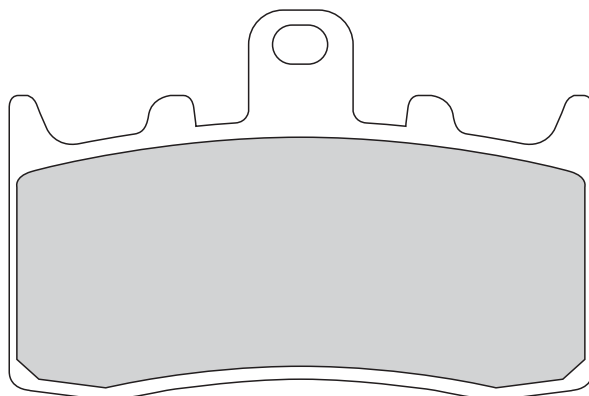

BMW	CC	MY	A	P
R 850 R ROADSTER	850	01	•	
R 850 RT	850	06	•	
R 850 RT ABS	850	01	•	
R 1100 Sno ABS	1100	01	•	
H2 MEGAMOTO	1150	07	•	
R 1150 GS	1150	02	•	
R 1150 RT	1150	01	•	
HP2 1200 MEGAMOTO	1200	07	•	
K 1200 RS	1200	01	•	

K 1200 GT	1200	02	05	•	
K 1200 GT ABS integrale	1200	08		•	
K 1200 GT IZQ/LEFT	1200	06		•	
K 1200 RT	1200	06		•	
K 1200 S	1200	04		•	
K 1200 S	1200	05		•	
K 1200 ST	1200	06		•	
R 1200 GS	1200	04	12	•	
R 1200 GS	1200	04		•	
R 1200 GS ADVENTURE	1200	06		•	

R 1200 RT	1200	05		•	
R 1200 RT	1200	06		•	
R 1200 RT SE	1200	10		•	
R 1200 S	1200	06		•	
R 1200 ST	1200	06		•	
K 1300 GT	1300	09		•	
K 1300 S	1300	09		•	

► P.231



93.3
93.9



36.6
36.4

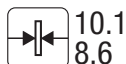

10.1
8.6

SINTERIZZATA
SINTERED
P.231ACX

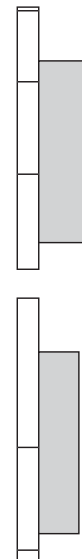
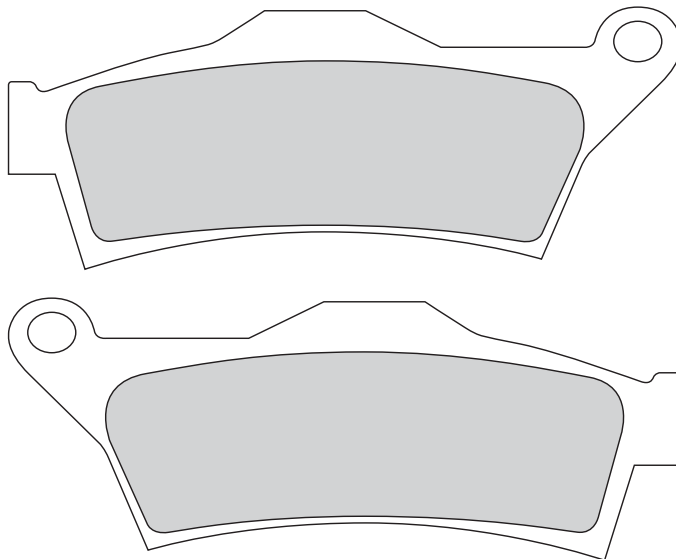

APRILIA	CC	MY	A	P
CAPONORD RAID	1000	03		•
BMW	CC	MY	A	P
R 850 R	850	04		•
R 850 R ROADSTER	850	95	00	•
R 850 R ROADSTER	850	01		•
R 850 RT	850	06		•
R 100 R CLASSIC - MYSTIC	1000	95		•
R 1100 R ROADSTER	1100	95		•
R 1100 RS NO ABS	1100	95		•
R 1100 RT ABS	1100	94	01	•
R 1100 RT NO ABS	1100	94	01	•

R 1100 S ABS	1100	01		•	
R 1100 S NO ABS	1100	01		•	
H2 ENDURO	1150	05		•	
H2 MEGAMOTO	1150	07		•	
H2 SPORT	1150	08		•	
R 1150 GS	1150	00	01	•	
R 1150 GS	1150	02		•	
R 1150 R ROADSTER	1150	01		•	
R 1150 ROCKESTER	1150	03		•	
R 1150 RS	1150	01		•	
R 1150 RT	1150	01		•	
K 1200 R	1200	05		•	

K 1200 R SPORT	1200	07		•	
K 1200 RS ABS	1200	97	00	•	
K 1200 RT	1200	06		•	
K 1200 S	1200	04		•	
K 1200 ST	1200	06		•	
R 1200 C AVANTGARDE	1200	00		•	
R 1200 C INDEPENDENT	1200	01		•	
R 1200 C MONTAUK	1200	04		•	
R 1200 CRUISER	1200	97		•	
R 1200 GS	1200	04	12	•	
R 1200 GS ADVENTURE	1200	06		•	
R 1200 R	1200	11		•	

PASTIGLIE FRENO BRAKE PADS

► P.231

BMW	CC	MY	A	P
R 1200 R	1200	06 10		•
R 1200 RT SE	1200	10		•
R 1200 S	1200	06		•

R 1200 ST	1200	05		•
K 1300 GT	1300	09		•
K 1300 R	1300	09		•
K 1300 S	1300	09		•
K 1600 GT	1600	11		•
K 1600 GTL	1600	11		•

MOTO GUZZI	CC	MY	A	P
NORGE	1200	06		•
NORGE 1200 GT 8V	1200	11		•

► P.232



38



49



7.9

SINTERIZZATA
SINTERED
P.232ACX

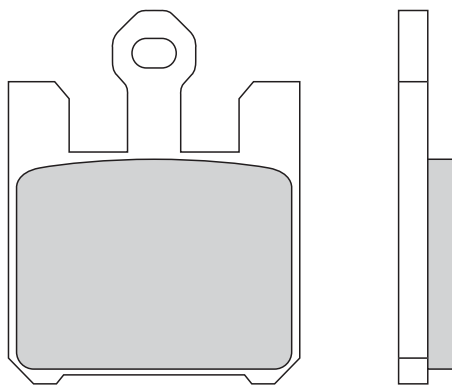

DERBI	CC	MY	A	P
MULHACEN 659	659	05		•
KAWASAKI	CC	MY	A	P
ZX 6RR 600 NINJA	600	05		•
ZX 6R 636 NINJA	636	03		•
Z 750 R	750	11		•
Z 750 R ABS	750	11		•

Z R	750	11		•
Z	1000	07 09		•
ZX 12R 1200 NINJA	1200	04		•
GTR	1400	07		•
GTR GRAND TOUR	1400	10		•
ZG CONCOURS	1400	08		•
ZG CONCOURS ABS	1400	08		•

ZX 14R	1400	06		•
ZZR	1400	06		•
VN 1600 MEAN STREAK	1600	05		•
SUZUKI	CC	MY	A	P
GSX R 1000	1000	03		•
M 1600 INTRUDER	1600	05		•

► P.233



85



51



8

SINTERIZZATA
SINTERED
P.233ACX

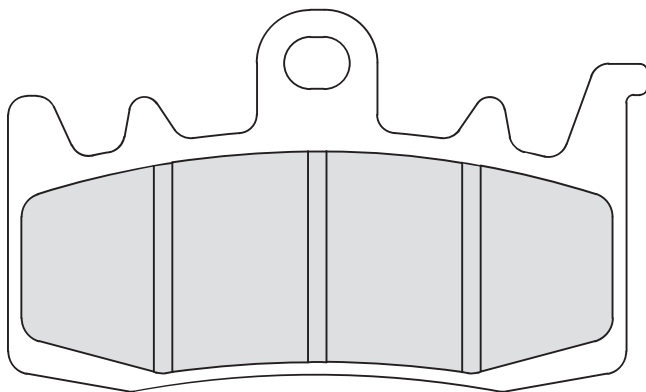

APRILIA	CC	MY	A	P
RSV 1000 TUONO V4R	1000	14		•
RSV 1000 TUONO V4	1100	15		•
CAPONORD	1200	13		•
CAPONORD 1200	1200	13		•
CAPONORD RALLY 1200	1200	15		•
BMW	CC	MY	A	P
R 800	800	15		•
XR 1000	1000	15		•
R 1200 GS	1200	13		•
R 1200 GS	1200	14		•
R 1200 GS ADVENTURE	1200	14		•
R 1200 NINET	1200	14		•

R 1200 R S	1200	15		•
R 1200 RT	1200	14		•
DUCATI	CC	MY	A	P
SCRAMBLER CLASSIC	800	15		•
SCRAMBLER ENDURO	800	15		•
SRAMBLER ICON	800	15		•
HYPERMOTARD	821	13		•
HYPERMOTARD SP	821	13		•
HYPERSTRADA	821	13		•
MONSTER	821	15		•
MONSTER DARK	821	15		•
899 PANIGALE	899	14		•
MONSTER 1200	1200	14		•

MULTISTRADA 1200	1200	15		•
MV AGUSTA	CC	MY	A	P
RIVALE	800	13		•
RIVALE 800	800	13		•
STRADALE 800	800	15		•
TURISMO VELOCE 800	800	14		•

PASTIGLIE FRENO BRAKE PADS

► P.234



69



49



7

SINTERIZZATA
SINTERED
P.234ACX

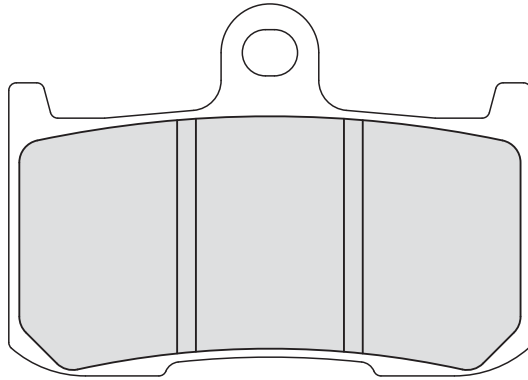

KAWASAKI	CC	MY	A	P
Z 800	800	13	•	
ZX9 900 R NINJA	900	02	•	
Z	1000	03 06	•	
Z 1000ZR	1000	03	•	
SUZUKI	CC	MY	A	P
GSX 1300 B KING	1300	08	•	

TRIUMPH	CC	MY	A	P
DAYTONA 675	675	06	•	
STREET TRIPLE R 675	675	09	•	
STREET TRIPLE R 675	675	13	•	
STREET TRIPLE RX 675	675	15	•	
SPEED TRIPLE	1050	05 07	•	
SPEED TRIPLE 1050	1050	05	•	

TIGER 1050	1050	07	•	
TIGER SE 1050	1050	09	•	
TIGER SPORT	1050	15	•	

► P.235



81



45



9

SINTERIZZATA
SINTERED
P.235ACX

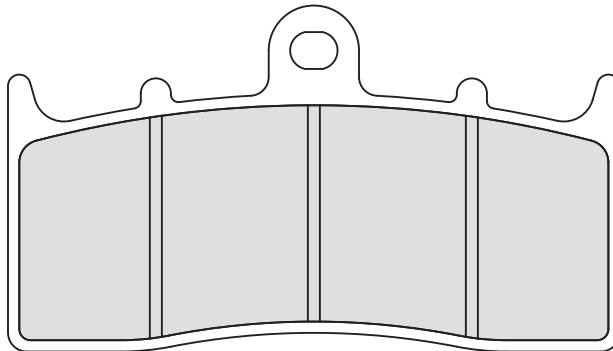

BMW	CC	MY	A	P
R 850 R	850	04	•	
R 1100 S ABS	1100	01	•	
R 1150 R	1150	01	•	
R 1150 R ROADSTER	1150	01	•	
R 1150 R con freno integrale	1150	01	•	
R 1150 RS con freno integrale	1150	01	•	
K 1200 LT ABS integrale	1200	02	•	

K 1200 R	1200	05	•	
K 1200 R SPORT	1200	07	•	
R 1200 C CLASSIC	1200	03	•	
R 1200 C INDIPENDENT	1200	03	•	
R 1200 C MOTAUKE	1200	04	•	
R 1200 CL	1200	03	•	
R 1200 LT con freno integrale	1200	02	•	
R 1200 R	1200	05	•	

K 1300 R	1300	09	•	
K 1300 R DYNAMIC	1300	11	•	
K 1600 GT	1600	11	•	
K 1600 GTL	1600	11	•	
KAWASAKI	CC	MY	A	P
ZRX 400ZR 400 E2	400	99	•	

PASTIGLIE FRENO BRAKE PADS

► P.236

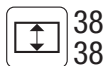

SINTERIZZATA
SINTERED
P.236ACX

ORGANICA STRADALE
ROAD ORGANIC
P.236ASX

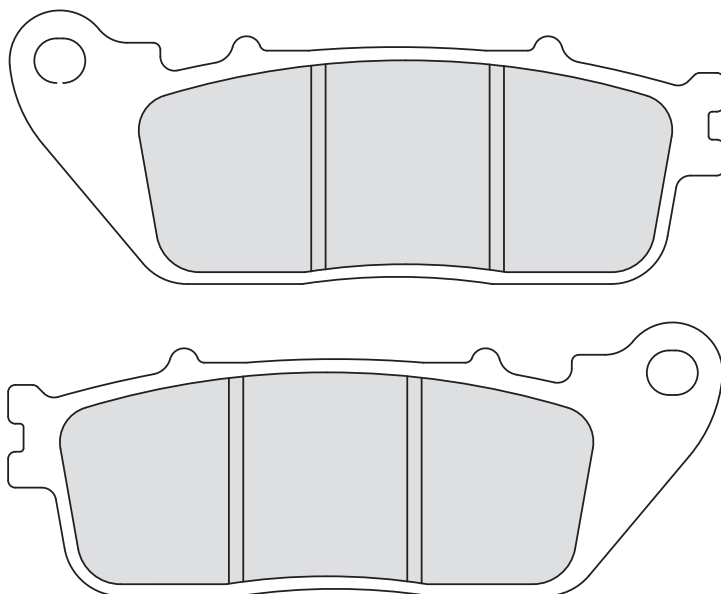

HONDA	CC	MY	A	P
800 CROSSRUNNER	800	11		•
VFR 800 FI	800	14		•

VFR 800 X CROSSRUNNER	800	15		•
CB 1000 R	1000	08		•
CB 1000 R ABS	1000	08		•

VFR 1200 F	1200	10		•
------------	------	----	--	---

► P.237

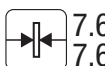
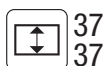

SINTERIZZATA
SINTERED
P.237ACX

ORGANICA STRADALE
ROAD ORGANIC
P.237ASX

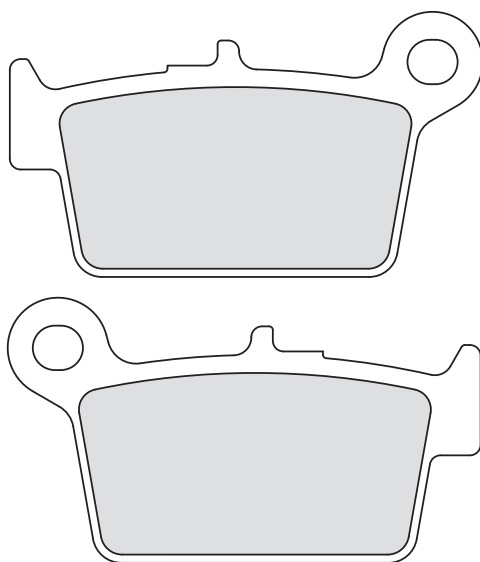

BETA	CC	MY	A	P
RR 50 ENDURO	50	05		•
RR 50 SUPERMOTARD	50	08		•
RR 50 SUPERMOTARD ALU	50	04		•
ALP 125 4T	125	06		•
RR 125 4T	125	05		•
RR 125 4T RE	125	08		•
RR 125 ENDURO 4T EU3	125	08		•
RR 125 ENDURO EU3	125	07		•
RR 125 MOTARD 4T EU3	125	08		•
RR 125 MOTARD EU3	125	07		•
URBAN 125	125	08		•
ALP 200 4T	200	06		•

URBAN 200	200	08		•
ALP 350 4.0	350	04		•
MOTARD 350 4.0	350	04		•

PASTIGLIE FRENO BRAKE PADS

► **P.238**



97



39



7.1

SINTERIZZATA
SINTERED
P.238ACX

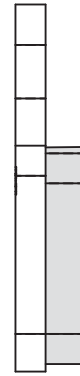
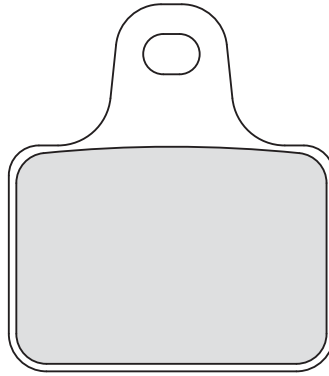

BIMOTA	CC	MY	A	P
DB9 BRIVIDO S	1198	11	•	
DB9 BRIVIDO SC	1198	11	•	

► **P.239**



109
111



41
44



8
8

ORGANICA STRADALE
ROAD ORGANIC
P.239ASX

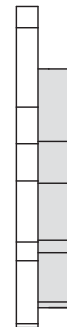
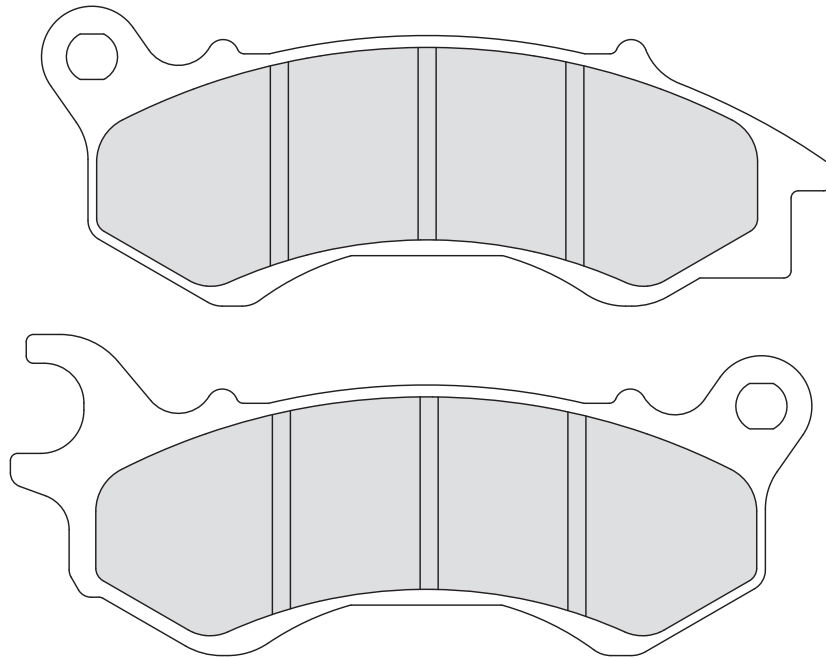

HONDA	CC	MY	A	P
PCX 125	125	10	•	

PASTIGLIE FRENO BRAKE PADS

► P.240



ORGANICA STRADALE
ROAD ORGANIC
P.240ASX

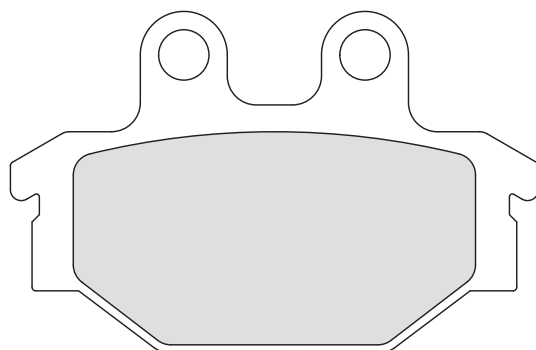
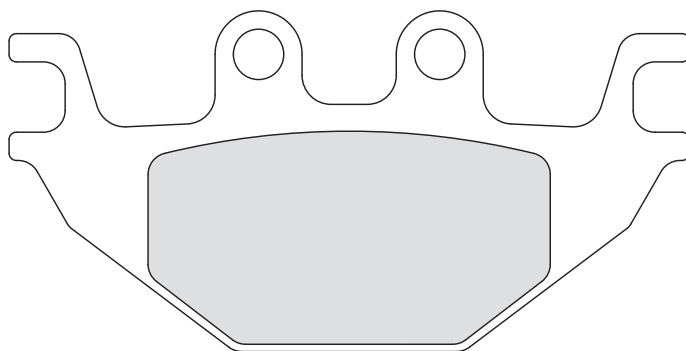

ADLY ATV	CC	MY	A	P
CROSS X OVER 300	300	07	•	
CROSS X ROAD 300	300	07	•	
SPORT 300	300	07	•	
S 320	320	07	•	
U 320	320	07	•	

CPI	CC	MY	A	P
XS 250	250	07	•	

KYMCO ATV	CC	MY	A	P
KXR 250	250	03	•	
MXU 250	250	05	•	

YAMAHA	CC	MY	A	P
MT 125	125	14		•
R1 125YZF 125 R	125	08		•
YZFR 125	125	14		•

► P.241



SINTERIZZATA
SINTERED
P.241ACX

ORGANICA STRADALE
ROAD ORGANIC
P.241ASX

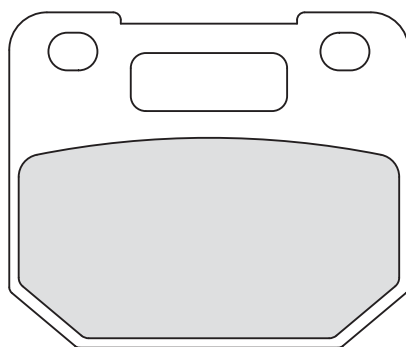

SUZUKI	CC	MY	A	P
RG 80 GAMMA	80	88	•	
RG 125 W GAMMA	125	85	•	

PASTIGLIE FRENO BRAKE PADS

► P.242



74



54

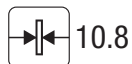

10.8

SINTERIZZATA
SINTERED
P.242ACX

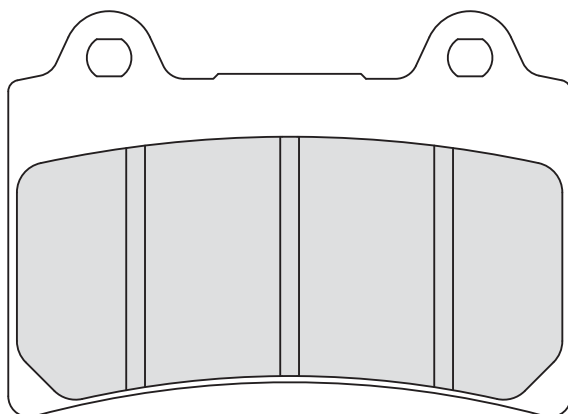

YAMAHA	CC	MY	A	P
R1 250 Z	250	90	•	
TDR 250	250	88	•	
TZ 250	250	85	•	
TZ 250 COMPETITION	250	88	•	
TZR 250	250	85	•	

FZR 400 R	400	87	•	
SRX 400	400	87	•	
SRX 600	600	87	•	
TDM 850	850	91	•	
FZR 1000 GENESIS EXUP	1000	86	•	
FJ 1200 W WC	1200	89	•	

XV 1300 AH/ATH ROYAL STAR 1300	96		•	
XVZ 1300 TD	1300	88	•	•
XVZ 1300 TF ROYAL STAR VENTURE 1300	99		•	
XV 1600 ROAD STAR SILVERADO 1600	99		•	
XV 1700 ROAD STAR WARRIOR 1700	02		•	

► P.243



100



38



9.5

SINTERIZZATA
SINTERED
P.243ACX

ORGANICA STRADALE
ROAD ORGANIC
P.243ASX

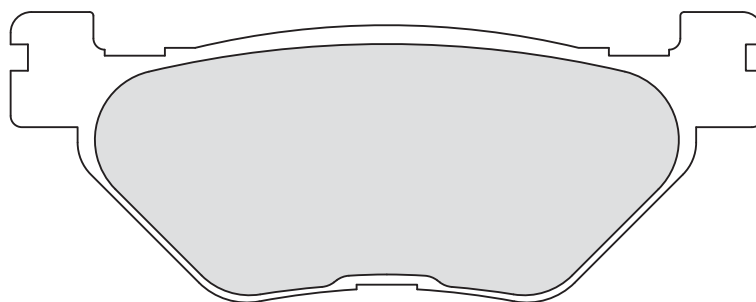

HYOSUNG	CC	MY	A	P
GV 650 AGUILA	650	04		•
YAMAHA	CC	MY	A	P
TDM 900	900	02		•
TDM 900 A	900	05		•
XVS 950 A MIDNIGHT STAR	950	09		•
XTZ 1200 SUPER TENERE	1200	10		•
XTZ 1200 ZE	1200	14		•

1300 STRYKER	1300	11		•
FJR 1300	1300	01		•
FJR 1300 A	1300	03		•
FJR 1300 A ABS	1300	06		•
FJR 1300 A ABS	1300	11		•
FJR 1300 ABS	1300	06		•
FJR 1300 AS	1300	06		•
XVS 1300 A MIDNIGHT STAR	1300	07		•

XV 1670 ROYALS STAR WARRIOR 1670	02		•	
V MAX 1700	1700	09		•
XV 1700 PC ROAD STAR WARRIOR 1700	03		•	
XV 1700 WARRIOR	1700	03		•
XV 1900 A MIDNIGHT STAR	1900	07		•
XV 1900 MIDNIGHT STAR	1900	06		•

PASTIGLIE FRENO BRAKE PADS

► P.244

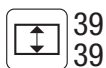

SINTERIZZATA
SINTERED
P.244ACX

ORGANICA STRADALE
ROAD ORGANIC
P.244ASX

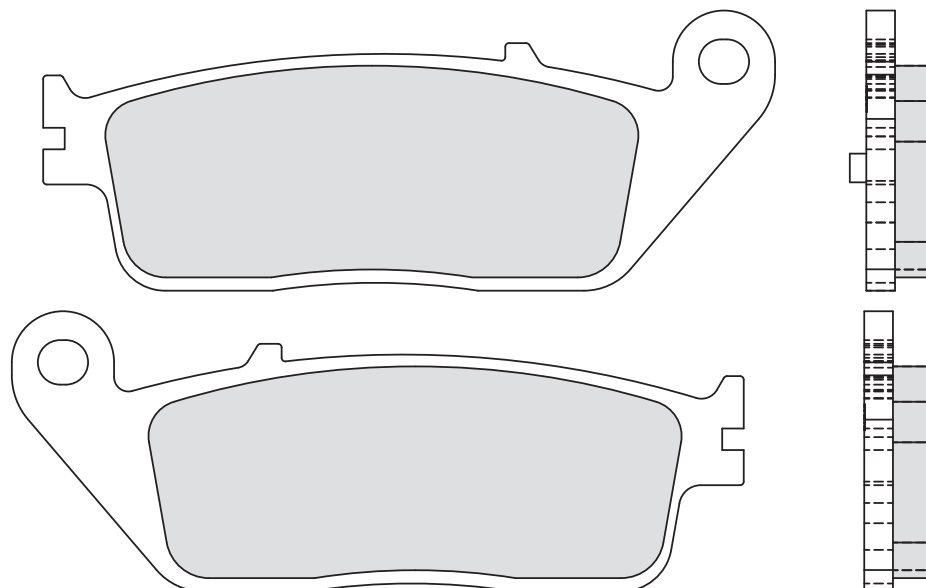

KYMCO	CC	MY	A	P
XCITING 400 I	400	12		•
XCITING 500	500	05		•

XCITING 500 I	500	06		•
XCITING 500 I R	500	07		•
MY ROAD 700	700	09		•

► P.245



SINTERIZZATA
SINTERED
P.245ACX

ORGANICA STRADALE
ROAD ORGANIC
P.245ASX

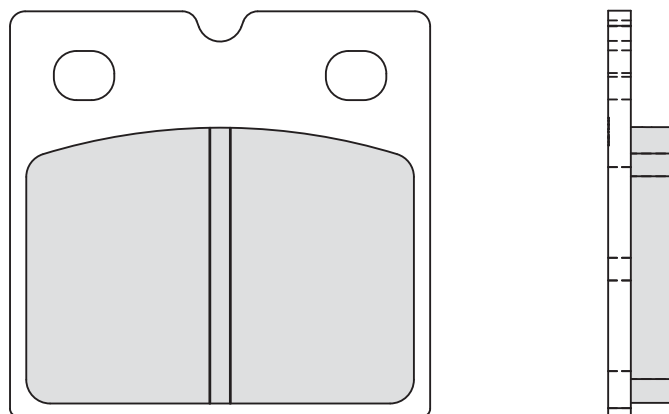

APRILIA	CC	MY	A	P
AF1 250 REPLICA	250	90		•
BENELLI	CC	MY	A	P
350 SPORT	350	78		•
350 SPORT II	350	78		•
350 T	350	78		•
500	500	78		•
500 LS	500	78		•
650	650	82		•
650 SPORT	650	78		•
650 T	650	78		•
SEI 750	750	76	•	
SEI 900	900	78		•
BIMOTA	CC	MY	A	P
BELLARIA 600 SPORT	600	91		•
TESI 851 1D	851	91		•
TESI 906 1D	906	91		•
1000 all models >1988	1000			•

SB 3 1000	1000	83		•	•
YB 10 DIECI 1002	1002	91			•
BMW	CC	MY	A	P	
R 45 450	450	81		•	
R 65 650	650	81		•	
R 65 650 GS	650	87		•	
R 65 650 LS	650			•	
K 75 750	750	90			•
K 75 750	750			•	
K 75 750 RT	750	91			•
K 75 750 S	750	88			•
K 75 750 S	750			•	•
K 75 750 pinza ABS	750	91			•
R 80 800 GS/PARISDAKAR	800	81		•	
R 80 800 all models	800	82		•	
R 80 800 all models	800	85		•	
K 1 1000	1000	89			•
K 100 1000 LT	1000	88			•

K 100 1000 RS	1000	88			•
K 100 1000 RS	1000	90			•
K 100 1000 all models	1000				•
K 100 1000 pinza ABS	1000	91			•
R 100 1000 RS RT CS	1000	81			•
R 100 1000 all models	1000	81			•
R 100 1000 all models *	1000	81			•
K 1200 RS	1200	97			•
K 1200 RS	1200	01			•
CZ JAWA	CC	MY	A	P	
CZ 125 2T	125				•
CZ 125 MX	125				•
CZ 180	180	92			•
TRAIL 300	300	93			•
DUCATI	CC	MY	A	P	
250 DESMO	250				•
350 DESMO	350				•
600 SL	600	76			•

PASTIGLIE FRENO BRAKE PADS

P.245

DUCATI	CC	MY	A	P
600 TL PANTAH	600	76	•	•
650 DESMO	650	87	•	•
750 ENDURANCE	750	87	•	•
750 F1 DESMO	750	86	•	•
750 LAGUNA SECA	750	87	•	•
750 PASO	750	87	•	•
750 SPORT	750	88	•	•
750 SPORT	750		•	•
750 SS	750	76	•	•
906 PASO	906	89	•	•
1000 MILLE REPLICA	1000	05	•	•
1000 S2 DESMO	1000	85	•	•
1000 all models	1000	84	•	•
HOREX	CC	MY	A	P
REBELL 80 T	80	86	•	•
SPORT 80 L	80	86	•	•
IMPERATOR 125	125	96	•	•
REGENT 125	125	96	•	•
E 560	560	86	•	•
COLUMBUS 600	600	87	•	•
LAVERDA	CC	MY	A	P
125	125		•	•
SFC 500	500	77	•	•
SF3 750	750	77	•	•
3CE 1000	1000	74	•	•
JOTA 1000	1000	95	•	•

RGS 1000	1000	83	•	•
RGS 1000 CORSA	1000		•	•
RGS 1000 JOTA	1000	77	•	•
RGS 1000 JOTA	1000	86	•	•
SFC 1000	1000	85	•	•
TGA 1000 EXECUTIVE	1000	84	•	•
MIRAGE 1200	1200	78	•	•
T.T. 1200	1200	76	•	•
MOTO GUZZI	CC	MY	A	P
NTX 350	350	90	•	•
V 35 350 GT	350	90	•	•
NTX 650	650	90	•	•
V 65 650 GT	650	90	•	•
NTX 750	750	90	•	•
S 750	750	74	•	•
S3 750	750	75	•	•
CALIFORNIA 850 T3	850	75	•	•
LE MANS 850	850	76	•	•
T 850	850	74	•	•
T 5 850	850	84	•	•
T3 850	850	75	•	•
T4 850	850	80	•	•
CALIFORNIA 1000 III C	1000	91	•	•
DAYTONA 1000	1000	91	•	•
GT V 1000	1000	91	•	•
LE MANS 1000	1000	84	•	•
LE MANS V 1000	1000	90	•	•
SP 1000	1000	78	•	•
SP 1000 II	1000	84	•	•

SP III 1000	1000	91	•	•
V 1000 1000 G5	1000	78	•	•
V 1000 1000 I CONVERT	1000	75	•	•
CALIFORNIA 1100	1100	94	•	•
SPORT 1100	1100	01	•	•
MZ	CC	MY	A	P
ETZ 125	125	82	•	•
ETZ 125	125	85	•	•
ROADSTAR 125	125		•	•
SPORTSTAR 125	125	93	•	•
ETZ 150	150	82	•	•
ETZ 250	250	82	•	•
SPORTSTAR 251	251	96	•	•
ETZ 300	300	88	•	•
ETZ 301	301	90	•	•
SPORTSTAR 301	301	96	•	•
SAXON 500 all models	500	92	•	•
SILVER 500 STAR CLASSIC	500	93	•	•
SWM	CC	MY	A	P
XP 350 SAHARA	350	83	•	•
TRIUMPH	CC	MY	A	P
BONNEVILLE 750 UK	750	87	•	•
ZUNDAPP	CC	MY	A	P
KS 125	125	82	•	•
KS 175	175	82	•	•

P.246



SINTERIZZATA
SINTERED
P.246ACX

ORGANICA STRADALE
ROAD ORGANIC
P.246ASX

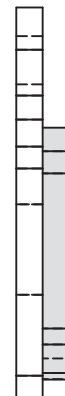
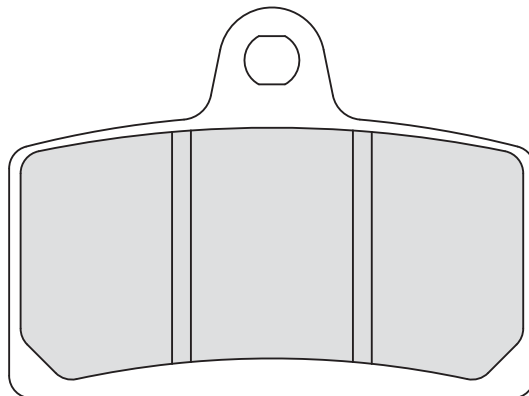

APRILIA	CC	MY	A	P
RS4 504T	50	11	•	•
RS4 1254T	125	11	•	•
RS4 1254T	125	12	•	•
BLATA	CC	MY	A	P
ENDURO 125	125	07	•	•
MOTARD 125	125	07	•	•
DERBI	CC	MY	A	P
GPR 125 4T	125	09	•	•
GPR 125 NUDE	125	04	•	•
GPR 125 RACING	125	04	•	•
METRAKIT	CC	MY	A	P
PRE GP 125	125	07	•	•
PEUGEOT	CC	MY	A	P
NK 7 50	50	09	•	•
XR 7 50	50	08	•	•

RIEJU	CC	MY	A	P
TANGO 125	125	06	•	•

PASTIGLIE FRENO BRAKE PADS

► P.247

82.1
62

40
40

8.4
8.4

SINTERIZZATA
SINTERED
P.247ACX

ORGANICA STRADALE
ROAD ORGANIC
P.247ASX

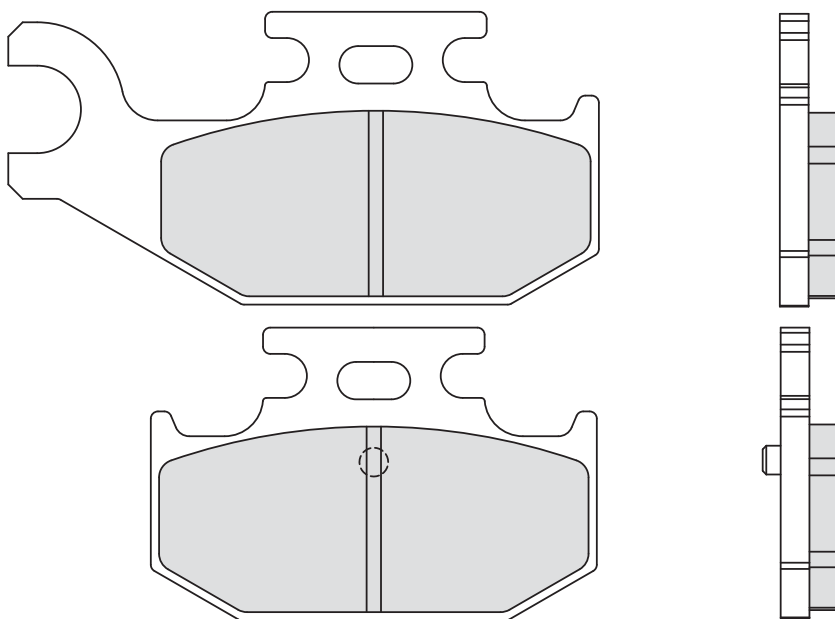

YAMAHA ATV	CC	MY	A	P
YXR 660 RHINO 4x4pinza sx	660	04		•
YFM 700 RAPTORpinza sx	700	06		•

► P.248

109
113

51
41

9.7
8.8

ORGANICA STRADALE
ROAD ORGANIC
P.248ASX

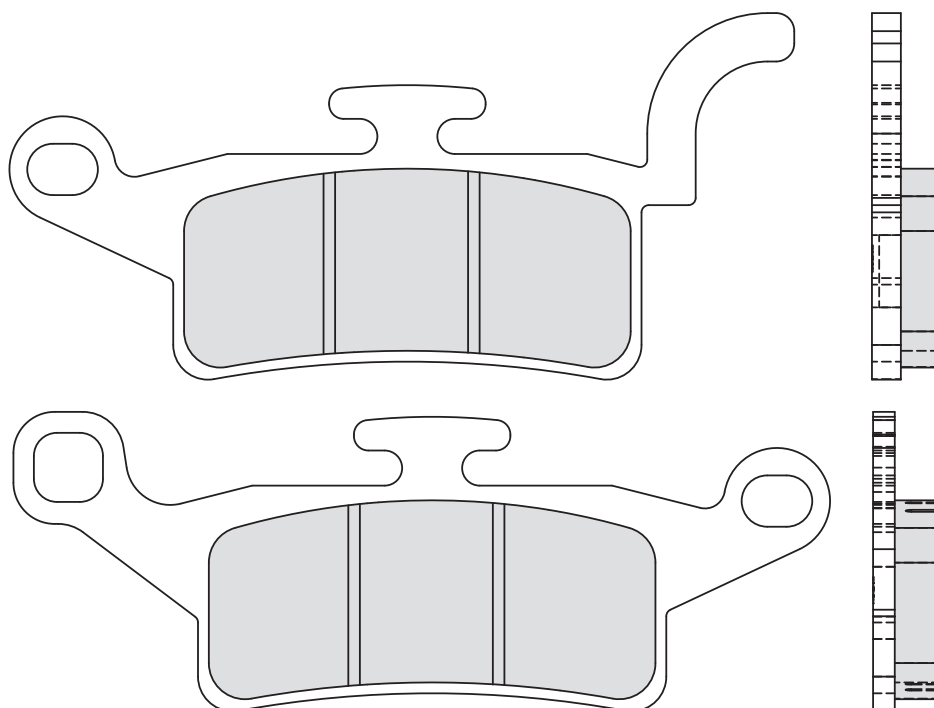

YAMAHA	CC	MY	A	P
HW 125 XENTER	125	12	•	
YW 125 BWS	125	10	•	
HW 150 XENTER	150	12	•	

PASTIGLIE FRENO BRAKE PADS

► P.249

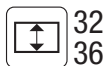

SINTERIZZATA
SINTERED
P.249ACX

ORGANICA STRADALE
ROAD ORGANIC
P.249ASX

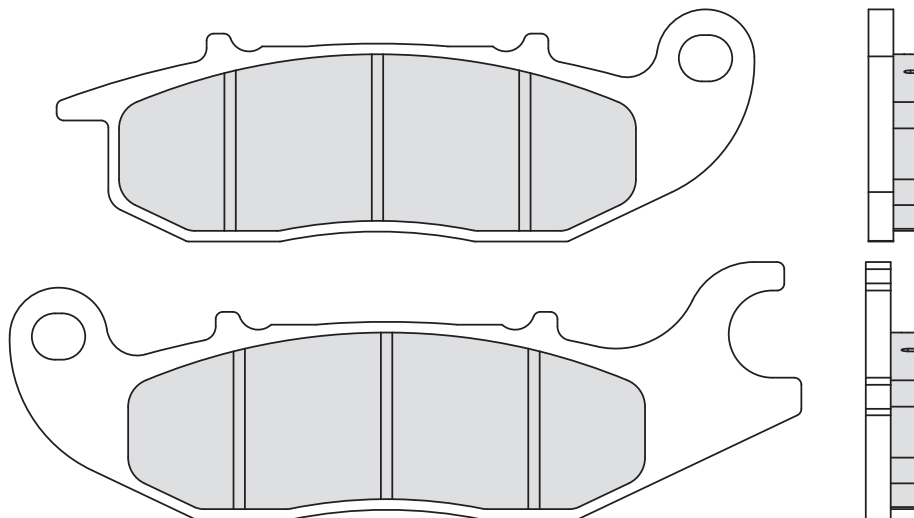

HONDA	CC	MY	A	P
ANF 125 INNOVA	125	03	•	
CBF 125	125	09	•	
CBR 125 R	125	04	•	

CBR 125 R	125	08	•	
GROM 125	125	14	•	
CBR R 150	150	00	•	

RIEJU	CC	MY	A	P
RS2 125 NKD	125	06	•	

► P.250



ORGANICA STRADALE
ROAD ORGANIC
P.250ASX

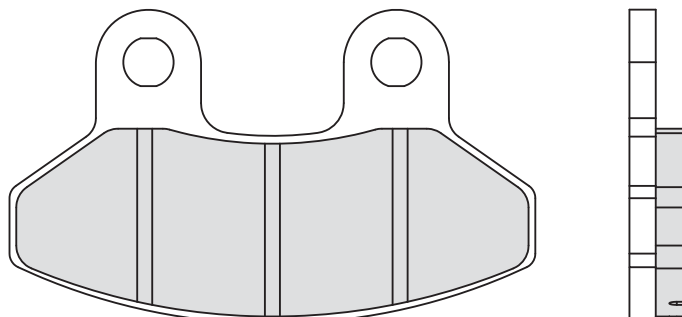

LAVERDA	CC	MY	A	P
PHOENIX 125	125	01	•	
PHOENIX 150	150	01	•	
PHOENIX 200	200	01	•	

RIEJU	CC	MY	A	P
RS2 125 PRO	125	08	•	

SYM	CC	MY	A	P
RS 21 50	50	02	•	
EURO 125 MX	125	03	•	
RS 125	125	05	•	
RS 21 125	125	02	•	
EURO 150 MX	150	03	•	

JOY RIDE 150	150	01	•	
RS 150	150	05	•	
JOY RIDE 200	200	01	•	

PASTIGLIE FRENO BRAKE PADS

► **P.251**



80
80



43
43

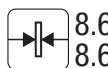

8.6
8.6

SINTERIZZATA
SINTERED
P.251ACX

ORGANICA STRADALE
ROAD ORGANIC
P.251ASX

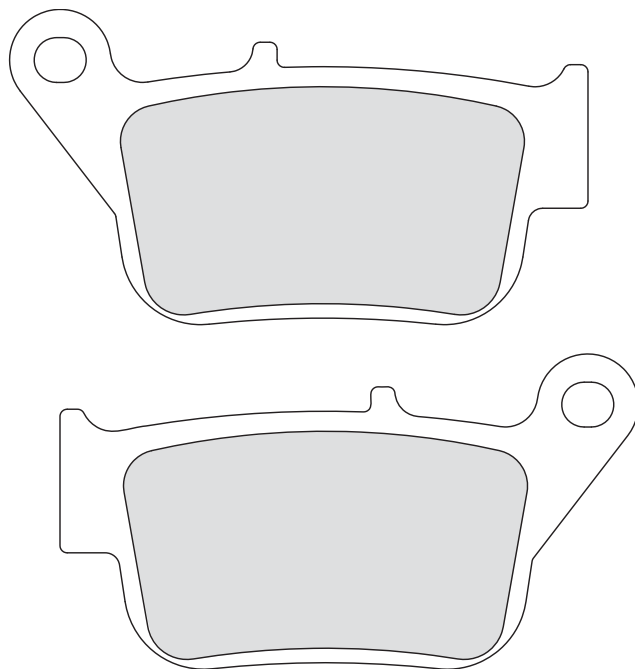

YAMAHA	CC	MY	A	P
YP R 250 XMAX	250	14		•

► **P.252**



88
88



40
40

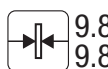

9.8
9.8

SINTERIZZATA
SINTERED
P.252ACX

ORGANICA STRADALE
ROAD ORGANIC
P.252ASX

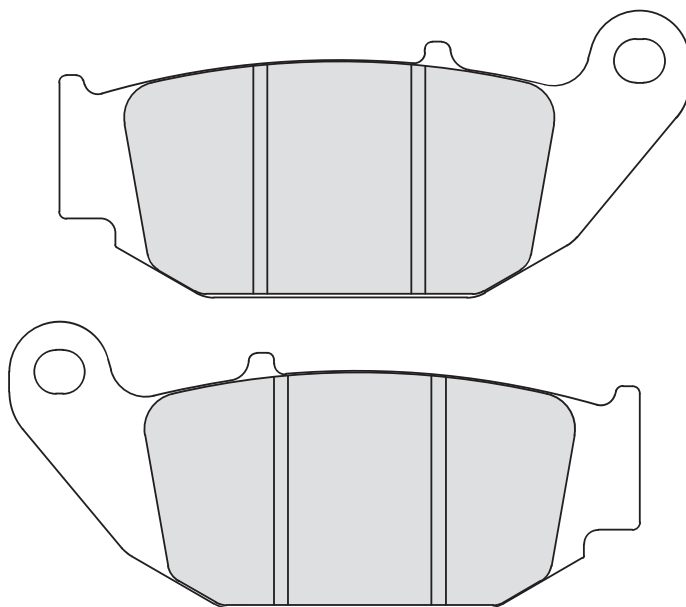

HONDA	CC	MY	A	P
CBR 125 R	125	08		•
GROM 125	125	14		•
MSX 125	125	14		•
CRF 250 L	250	14		•
CRF 250 M	250	14		•

PASTIGLIE FRENO BRAKE PADS

► P.253

110
96

51
37

8.4
8.4

ORGANICA STRADALE
ROAD ORGANIC
P.253ASX

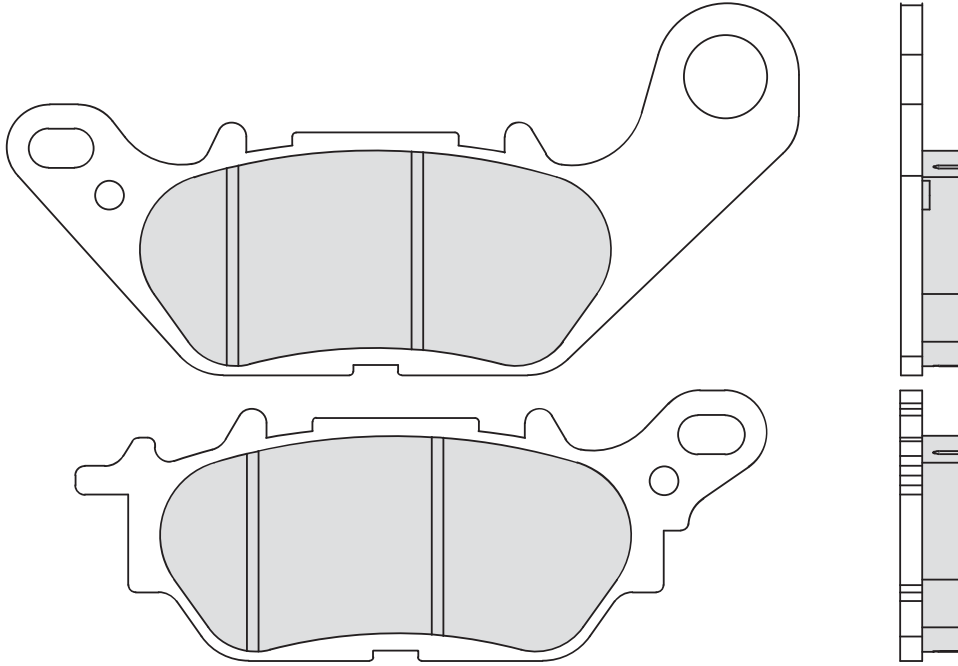

YAMAHA	CC	MY	A	P
XC 125 VITY	125	08	•	
YBR 125 ED	125	07	•	

CRYPTON 135 06 •

► P.254

90

39

10.3

ORGANICA STRADALE
ROAD ORGANIC
P.254ASX

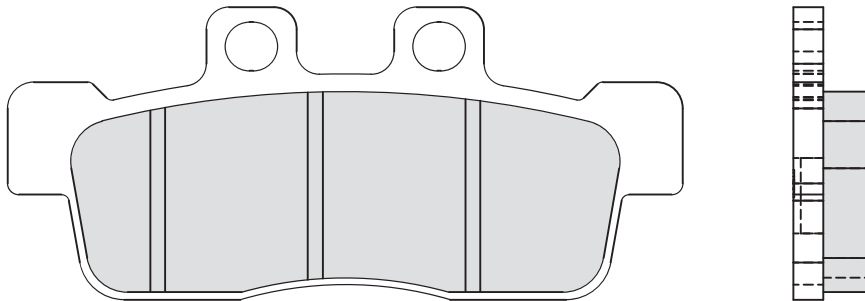

YAMAHA	CC	MY	A	P
NXC 125 CYGNUS	125	10	•	

PASTIGLIE FRENO BRAKE PADS

▶ P.255

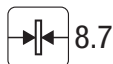

SINTERIZZATA
SINTERED
P.255ACX

ORGANICA STRADALE
ROAD ORGANIC
P.255ASX

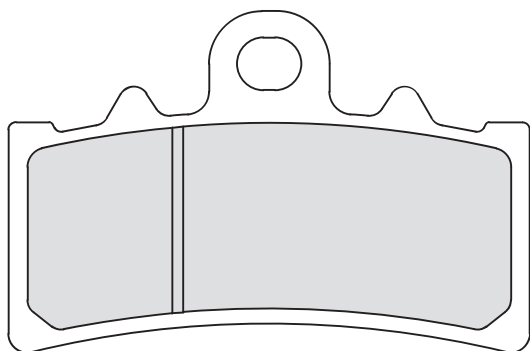

KTM	CC	MY	A	P
DUKE 125	125	11	•	
DUKE 390	390	13	•	

▶ P.256



SINTERIZZATA
SINTERED
P.256ACX

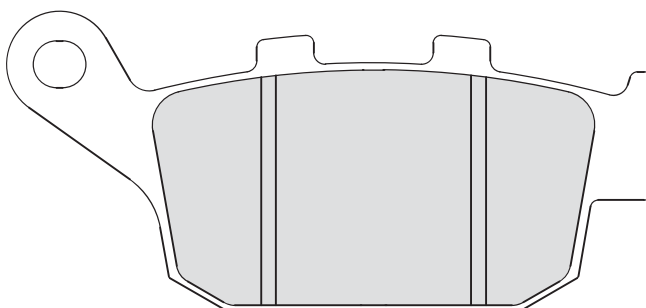
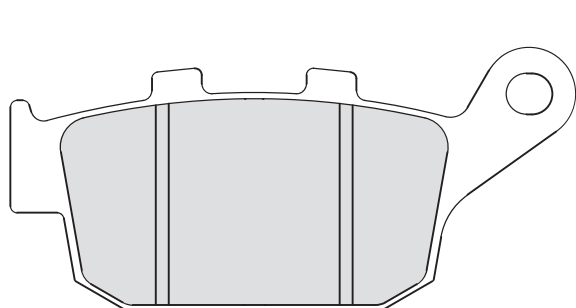

HONDA	CC	MY	A	P
CBR 250 R ABS	250	11		•
CBR 300 F	300	14		•
CBR 300 R	300	15		•
CB 500 F	500	13		•
CB 500 X	500	13		•
CB 650 F	650	14		•
CBR 650 F	650	14		•

CTX 700	700	14		•
CTX 700 D ABS w/DCT	700	14		•
CTX 700 N	700	14		•
CTX 700 ND ABS w/DCT	700	14		•
NM4 700 VULTUS ABSw/DCT	700	15		•
NC 750 D INTEGRA	750	14		•
NC 750 S w/DCT	750	14		•

KAWASAKI	CC	MY	A	P
Z 750 R	750	11		•
Z 800	800	15		•
Z 800	800	13		•
Z 800 ABS	800	13		•
Z 800 E	800	15		•

▶ P.258



SINTERIZZATA
SINTERED
P.258ACX

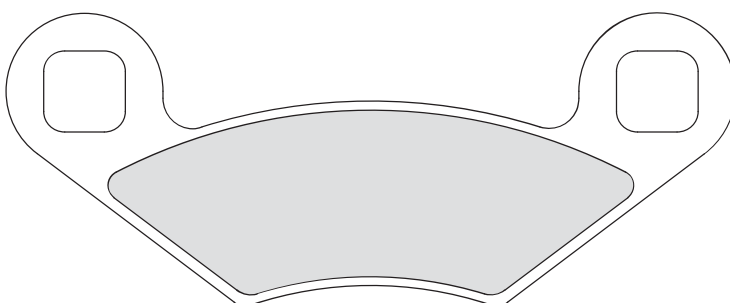

POLARIS ATV	CC	MY	A	P
TRAIL BOSS	250	88 90	•	
SPORTSMAN 4x4 WORKER	300	08		•
E TRAIL BLAZER	330	08		•

OUTLAW MXR 450	450	09		•
OUTLAW S 450	450	08		•
ATP 500 HO	500	04		•
E SCRAMBLER	500	08		•

REVOLVER	500	06		•
SPORTSMAN HO 500	500	03		•
OUTLAW 525	525	07		•
OUTLAW IRS 525	525	08		•

PASTIGLIE FRENO BRAKE PADS

P.258

POLARIS ATV	CC	MY	A	P
OUTLAW S 450	525	08		•

RANGER RZR EFI	570	12		•
SPORTSMAN 600	600	02	•	
RANGER RZR EFI 800	800	08		•
RANGER RZR S EFI 800	800	09		•

RZR 800	800	08		•
SPORTSMAN	800	05		•

P.259

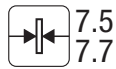

SINTERIZZATA
SINTERED
P.259ACX

ORGANICA STRADALE
ROAD ORGANIC
P.259ASX

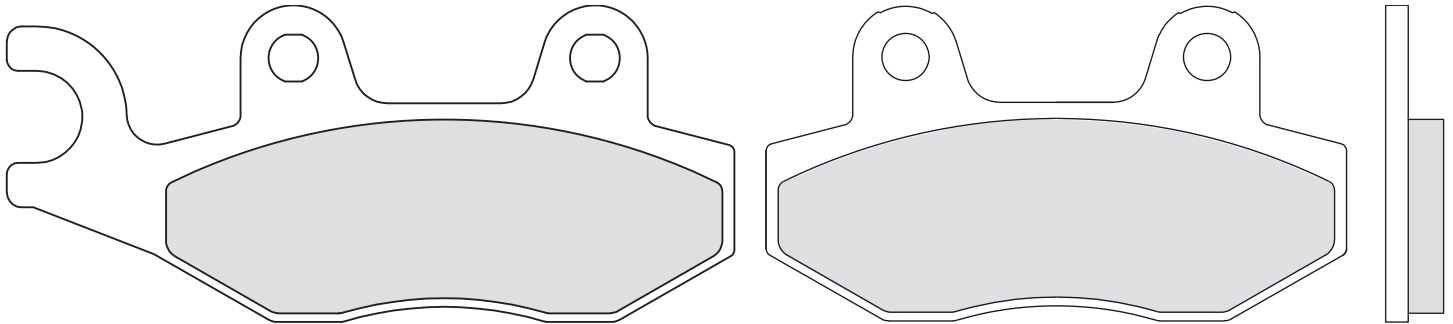

BENELLI	CC	MY	A	P
CAFFE NERO 250pinza dx	250	08		•
DAELIM	CC	MY	A	P
A FOUR 50	50	06		•
DELFINO 125	125	08		•
GENERIC	CC	MY	A	P
ZION 125	125	08		•
HONDA	CC	MY	A	P
CA 125 REBEL	125	95		•
CMX 250 C REBEL	250	96		•
KEEWAY	CC	MY	A	P
125 SUPERLIGHT	125	06		•
150 SUPERLIGHT	150	06		•
250 LAND CRUISER	250	06		•

KREIDLER	CC	MY	A	P
ENDURO 125	125	07		•
SUPERMOTO 125	125	07		•
KYMCO	CC	MY	A	P
FILLY 50 LX	50	02		•
VITALITY 50	50	04		•
YUP 50	50	02		•
VIVIO 125	125	01		•
VIVIO 150	150	01		•
PEOPLE S 250 Ipinza sx	250	07		•
PEOPLE S 250pinza sx	250	06		•
PEOPLE S 300 Ipinza sx	300	08		•
MALAGUTI	CC	MY	A	P
BLOG 125 IE	125	09		•
CENTRO 125 IE	125	08		•

CENTRO 125 SL IE	125	09		•
BLOG 160 IE	160	09		•
CENTRO 160 IE	160	08		•
CENTRO 160 SL IE	160	09		•
MZ	CC	MY	A	P
SM 125	125	02		•
SX 125	125	02		•
TGB	CC	MY	A	P
203 50	50	05		•
AKROS 50 TEC 5	50	99		•
APOLLO 50	50	99		•
FIRE 50	50	03		•
SKY 50	50	03		•
APOLLO 90	90	99		•

P.260



ORGANICA STRADALE
ROAD ORGANIC
P.260ASX

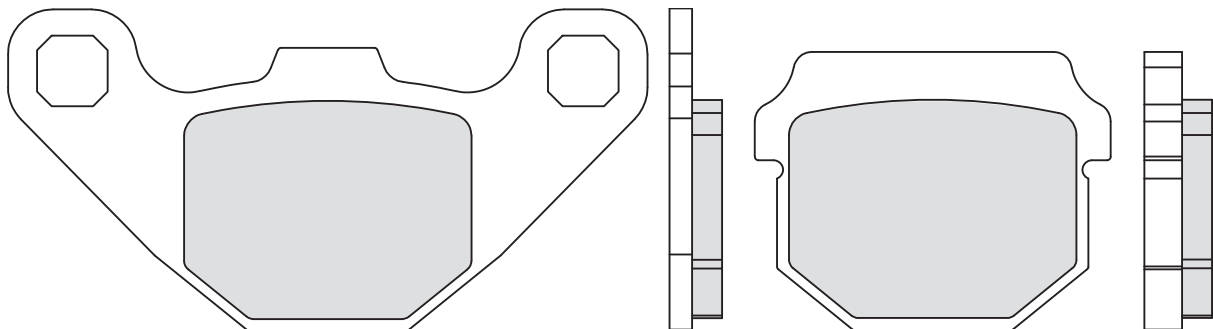

ADLY ATV	CC	MY	A	P
ATV 150	150	05		•
INTERCEPTOR 150	150	05		•
ATV 300	300	05		•
AEON	CC	MY	A	P
AERO 50	50	06		•
REGAL 50	50	06		•
TORCH 50	50	06		•
PULSAR 100	100	06		•
REVO 2 100	100	04		•
AERO 110	110	06		•

PULSAR 110	110	06		•
PULSAR 125	125	06		•
PULSAR 150	150	06		•
APRILIA	CC	MY	A	P
RS4 1254T	125	12		•
BOMBARDIER ATV	CC	MY	A	P
RALLY 200 2x4	200	03		•
CPI	CC	MY	A	P
BABY 50 J	50	02		•
HUSSAR 50	50	01		•
MARS 50	50	01		•

POPCORN 50	50	02		•
DAELIM	CC	MY	A	P
ST 250 SECTOR QUAD	250	05		•
ETON	CC	MY	A	P
RXL 50 VIPER	50	03		•
RXL 70 VIPER	70	03		•
RXL 90 VIPER	90	03		•
ST EXL 150 VIPER	150	05		•
VXL 250 VECTOR ST VECTOR 250	250	06		•
VTL 300 VORTEX ST VORTEX 300	300	07		•
VXL 300 VECTOR ST VECTOR 300	300	07		•

P.260

FACTORY	CC	MY	A	P
100 HELIX	100	04		•
100 REX	100	04		•
FACTORY ATV	CC	MY	A	P
HELIX 50	50	04		•
REX 50	50	04		•
HELIX 100	100	04		•
GARELLI	CC	MY	A	P
RAIDER 125	125	02		•
HONDA	CC	MY	A	P
MB 80	80	80		•
MCX 80 all models	80	82		•
HYOSUNG	CC	MY	A	P
FX 110	110	02		•
KR 110 MASTER	110	04		•
EXIV	125	12		•
KAWASAKI	CC	MY	A	P
AR 50	50	81		•
KMX 50	50	88		•
KSR 50 I/II	50	90		•
AR 80	80	81		•
KD 80	80	88		•
KX 80	80	88		•
KX 80 E2	80	84		•
KX 100	100	88		•
KDX 125 A1	125	90		•
KMX 125	125	86		•
KX 125 B1	125	81		•
KMX 200	200	88		•
KX 250 B1	250	82		•
KAWASAKI ATV	CC	MY	A	P
KXT 250 TECATE A1	250	84		•
KEEWAY	CC	MY	A	P
50 HURRICANE	50	06		•
90 HURRICANE	90	06		•
MAICO	CC	MY	A	P
C 1 50 HARD ENDURO	50	99		•
R 1 50 SUPERBIKE	50	99		•
THUNDERBIKE 50 I	50	99		•

X 1 50 SUPERCROSS	50	99		•
MALAGUTI	CC	MY	A	P
CENTRO 50 4T	50	08		•
CENTRO SL 50 4T	50	10		•
F 10 50 AC ECO	50	09		•
F 12 R 50 PHANTOM AC	50	09		•
F 12 R 50 PHANTOM LC	50	07		•
PETERSON	CC	MY	A	P
HURRICANE 50	50	95		•
SR 50 RACING	50	95		•
HURRICANE 80	80	95		•
SR 80 RACING	80	95		•
PEUGEOT	CC	MY	A	P
BUXI RS 50	50	94		•
SPEEDFIGHT M Pin. HengTong	50	97		•
SQUAB 50	50	96		•
TREKKER 50 ROAD	50	97		•
VIVACITY pinza HengTong	50	05		•
PGO	CC	MY	A	P
BIG MAX 50	50	03		•
COMET 50	50	91		•
GALAXI 50	50	92		•
GALAXI 90	50	92		•
MEGA 50	50			•
PS 50	50	93		•
PGO ATV	CC	MY	A	P
X RIDER 50	50	03		•
X RIDER 125	125	03		•
X RIDER 150	150	03		•
SIAM	CC	MY	A	P
MAT 50	50	97		•
MAT 100	100	97		•
SULA	CC	MY	A	P
THUNDER BIRD 50	50	99		•
THUNDER BIRD 100	100	99		•
THUNDER BIRD 125	125	99		•
SUZUKI	CC	MY	A	P
ADRESS 50	50	92		•
SEPIA 50	50	92		•
SEPIA AU 50 ZZ	50	96		•
TUNE 50	50	93		•

ZZ 50	50	92		•
LIDO 75	75	89		•
AH 80	80	92		•
RM 80 L/M	80	90		•
RM 80 X	80	86		•
RM 85	85	02		•
ADRESS 100 V	100	95		•
AN 125	125	06		•
LIDO 125 VARIO	125	90		•
UE 150	150	02		•
TGB	CC	MY	A	P
203 50	50	02		•
303 R 50	50	99		•
AKROS 50	50	99		•
ERAGON 50	50	96		•
HIWS 50	50	99		•
TRIGGER 50	50	99		•
101 S 90	90	99		•
202 S 90	90	99		•
AKROS 90	90	99		•
ERAGON 90	90	99		•
HIWS 90	90	99		•
TRIGGER 90	90	99		•
101 S 125	125	99		•
202 T 125	125	99		•
303 R 125	125	99		•
309 RACING	309	05		•
309 RS	309	00		•
507	507	05		•
TM	CC	MY	A	P
JUNIOR 80	80	96		•
UVM	CC	MY	A	P
BE THERE 50	50	99		•
BE THERE 125	125	99		•
BINGO 125	125	99		•
PARAGON 125	125	99		•
YAMAHA	CC	MY	A	P
DT 125	125	84		•

P.261



97
77



41
41



9
9

ORGANICA STRADALE
ROAD ORGANIC
P.261ASX

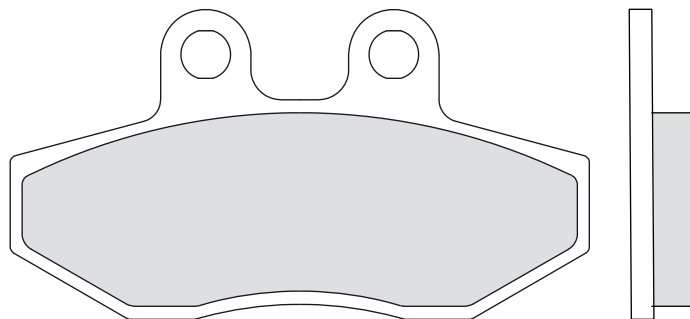
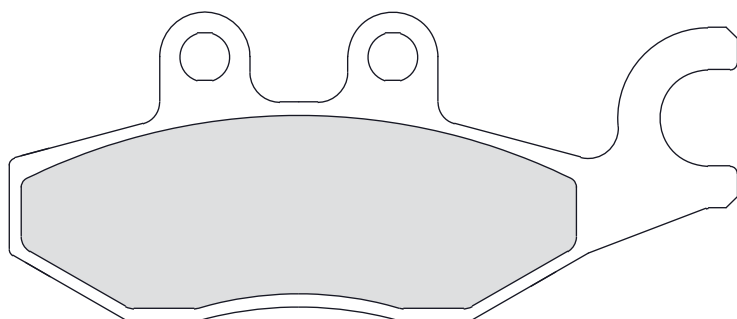

PIAGGIO	CC	MY	A	P
X 125 EVO	125	07		•
X9 125 EVOL. pin. dx HengTong	125	01		•
X9 125 EVOLUTION	125	05		•
MP3 250 MIC	250	08		•
X 250 EVO	250	07		•
X7 250 EURO 3	250	08		•

X9 250 EVOLUTIONpinza sx	250	05		•
X EVO 400pinza dx	400	07		•
X8 400 EURO 3pinza dx	400	06		•
X8 400pinza sx	400	06		•

PASTIGLIE FRENO BRAKE PADS

► P.262



68



55



8.8

SINTERIZZATA
SINTERED
P.262ACX

ORGANICA STRADALE
ROAD ORGANIC
P.262ASX

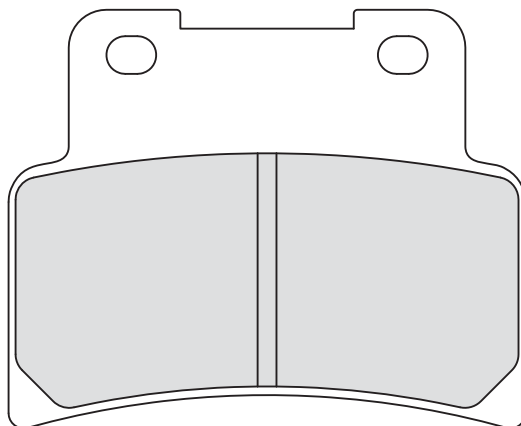

APRILIA	CC	MY	A	P
RS 125	125	06	•	
SL 750 SHIVER	750	07	•	
SL 750 SHIVER GT	750	09	•	
SMV 750 DORSODURO	750	09	•	
NA 850 MANA	850	07	•	

NA 850 MANA	850	08	•	
NA 850 MANA GT	850	09	•	
KYMCO	CC	MY	A	P
XCITING 400 I	400	12	•	
SYM	CC	MY	A	P
MAXSYM 400 I	400	11	•	

YAMAHA	CC	MY	A	P
MT 125	125	14	•	
YZFR 125	125	14	•	

► P.263



94



36



10.3

ORGANICA STRADALE
ROAD ORGANIC
P.263ASX

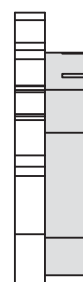
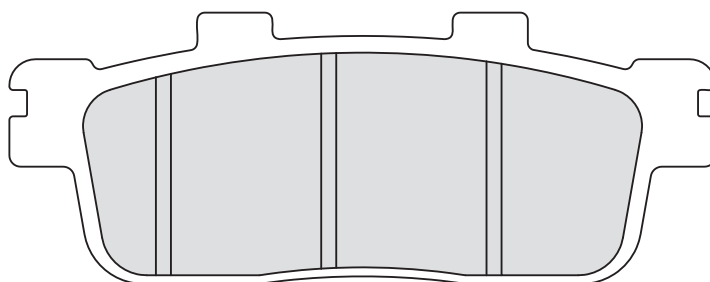

DAELIM	CC	MY	A	P
ST 250 SECTOR QUAD	250	05		•
ETON	CC	MY	A	P
RXL 150 VIPER	150	07		•
VXL 250 VECTOR ST VECTOR	250	06		•
VTL 300 VORTEX ST VORTEX	300	07		•
VXL 300 VECTOR ST VECTOR	300	07		•
SYM	CC	MY	A	P
HD 125	125	05		•

HD 125 EVO EURO3	125	10		•
HD2 125 EVO	125	14		•
JOY RIDE 125 EURO 2	125	05		•
JOY RIDE 125 EURO 3	125	07		•
HD 200 EVO EURO 2	200	05		•
HD 200 EVO I EURO 3	200	10		•
HD2 200 EVO	200	14		•
JOY RIDE 200 I EURO 3	200	07		•
JOY RIDE 200 I EVO	200	10		•

GTS 250	250	07		•
JOY MAX 300 EVO	300	09		•
JOY MAX 300 EVO I	300	10		•
SYM ATV	CC	MY	A	P
TRACK RUNNER 180	180	06		•
QUAD LANDER 250	250	06		•

PASTIGLIE FRENO BRAKE PADS

► P.264



SINTERIZZATA
SINTERED
P.264ACX

ORGANICA STRADALE
ROAD ORGANIC
P.264ASX

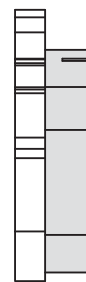
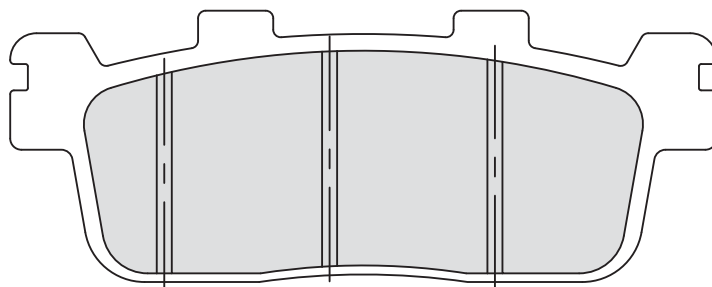

KYMCO	CC	MY	A	P
PEOPLE 125 EURO 3	125	07		•
PEOPLE S 125 DD	125	07		•
PEOPLE S 200 I	200	07		•

PEOPLE S 250 Ipinza sx	250	07		•
PEOPLE S 250pinza sx	250	06		•
XCITING 250	250	05		•
XCITING 250 i	250	06		•

PEOPLE S 300 Ipinza sx	300	08		•
XCITING 300 I R	300	08		•

► P.265

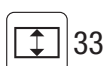

SINTERIZZATA
SINTERED
P.265ACX

ORGANICA STRADALE
ROAD ORGANIC
P.265ASX

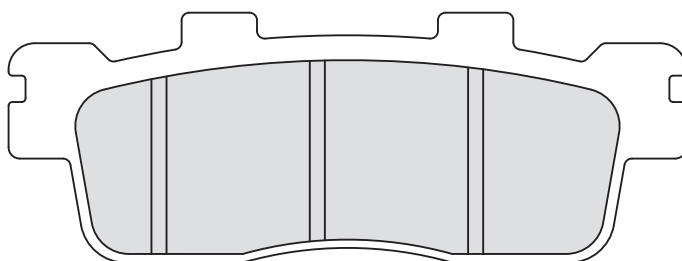

KYMCO	CC	MY	A	P
DOWNTOWN 125 I	125	09		•
PEOPLE GTI 125	125	10		•

SUPERDYNK 125	125	10		•
DOWNTOWN 200 I	200	10		•
PEOPLE GTI 200	200	10		•

DOWNTOWN 300 I	300	09		•
PEOPLE GTI 300	300	10		•

► P.266



SINTERIZZATA
SINTERED
P.266ACX

ORGANICA STRADALE
ROAD ORGANIC
P.266ASX

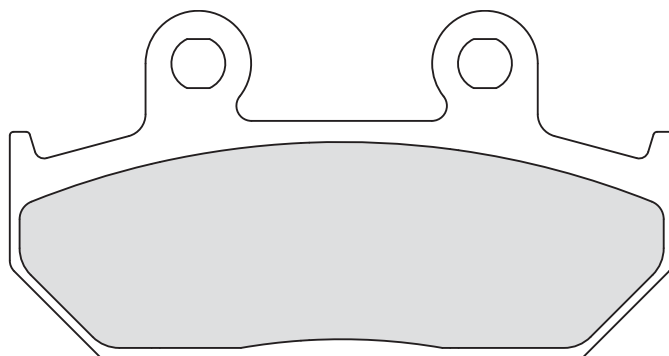

MALAGUTI	CC	MY	A	P
MADISON 3 125	125	06		•
MADISON 3 250	250	06		•

SUZUKI	CC	MY	A	P
AN 400 BURGMANpinza dx	400	07		•
AN 650 BURGMAN	650	03		•

PASTIGLIE FRENO BRAKE PADS

► P.267

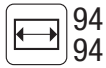

94
94

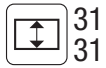

31
31

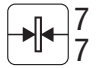

7
7

SINTERIZZATA
SINTERED
P.267ACX

ORGANICA STRADALE
ROAD ORGANIC
P.267ASX

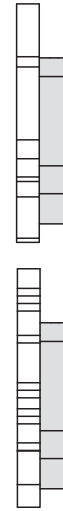
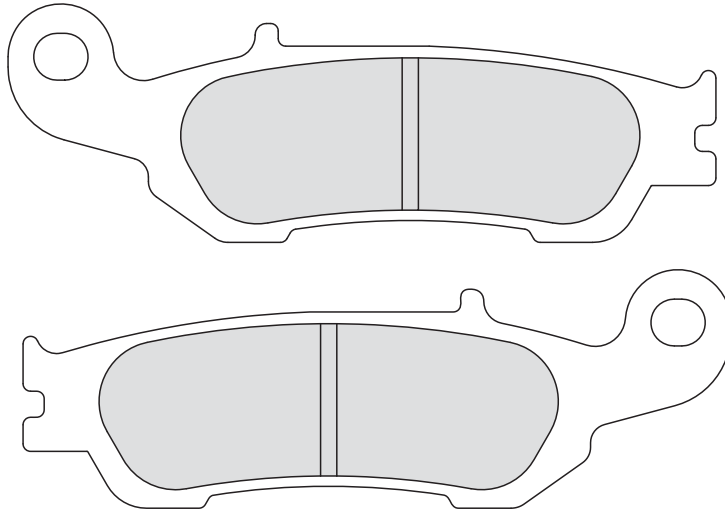

YAMAHA	CC	MY	A	P
YZ 125	125	08	•	
YZ 250	250	08	•	

YZ F 250	250	07	•	
YZ F 250 EFI	250	14	•	
YZ FX 250 EFI	250	15	•	

YZ F 450	450	08	•	
YZ F 450 EFI	450	14	•	

► P.268



38



50

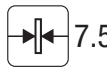

7.5

SINTERIZZATA
SINTERED
P.268ACX

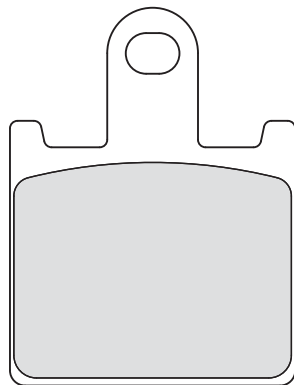

KAWASAKI	CC	MY	A	P
ZX 6R 600 NINJA	600	07	•	
Z 750 R	750	11	•	
Z 1000	1000	07	•	

Z 1000 ABS	1000	07	•	
GTR 1400	1400	07	•	
ZZR 1400 A6F	1400	06	•	
ZZR 1400 ABS B6F	1400	06	•	

SUZUKI	CC	MY	A	P
GSX 1300 B KING	1300	07	•	

Ganasce Freno

L'affermata tradizione nel settore dei materiali di attrito si riflette in una gamma di ganasce freno che consente di coprire i modelli di scooter e ciclomotori più diffusi. La perfetta compatibilità con il prodotto originale rende le ganasce ADIGE® un'ottima scelta. Tutte le ganasce ADIGE® sono prive di amianto.

STANDARD - ORGANICA STRADALE:

Prodotte con una miscela organica senza amianto, le ganasce ADIGE® garantiscono un perfetto equilibrio di frenata.

Caratteristiche:

- Componenti organici senza amianto
- Bassa usura
- Bassa rumorosità

Consigliate per: Scooter, ciclomotori e moto d'epoca.

Brake Shoes

The established tradition in the compound field is reflected in a brake shoe range that covers even the most obscure scooter, moped and vintage motorcycle. Perfect compatibility with the original product make ADIGE® brake shoes the perfect choice for every bike. All ADIGE® brake shoes are asbestos free.

STANDARD - ORGANIC FOR STREET USE:

Produced with a organic asbestos free compound, ADIGE® brake shoes assure a perfect balance during the application of brakes.

Features:

- Rubber based - asbestos free compound
- Low wear
- Low noise

Suggested for: Scooters, mopeds and vintage motorcycles





Diametro Esterno (mm) External Diameter	Spessore (mm) Thickness	Codice Adige® Adige® Part #	Diametro Esterno (mm) External Diameter	Spessore (mm) Thickness	Codice Adige® Adige® Part #
25	20	0130	125	17	0162
95	20	01260AVX	125	25	0280
100	20	0266	135	16	0187
100	20	0275	140	25	0278
110	25	0265AVX	140	25	0281
110	25	01200	150	25	024
110	25	01205	150	24	0159
110	25	01270AVX	150	24	0161
110	25	01284	160	32	0176
120	25	01274			

▶ 024

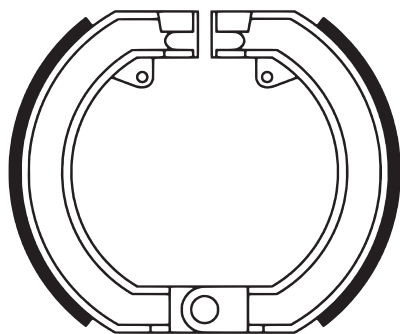

VESPA	CC	MY	A	P
VESPA SPRINT VELOCE	150		•	
VESPA GS	160		•	
VESPA RALLY	200	87	•	



▶ 0130

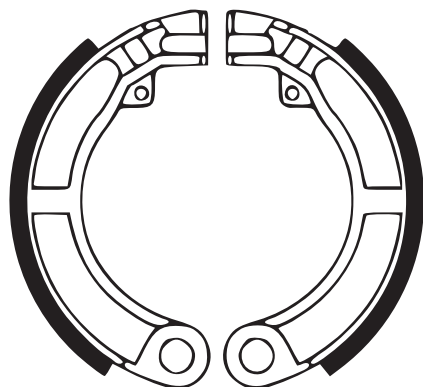

VESPA	CC	MY	A	P
VESPA	50	63		•



▶ 0159

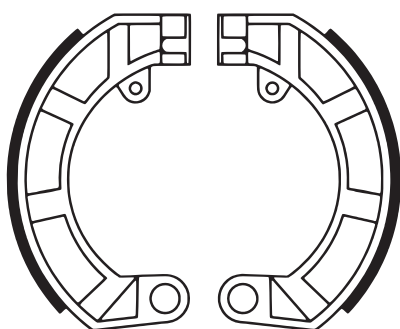

VESPA	CC	MY	A	P
VESPA SPECIAL	50			•
VESPA ET3	125			•
VESPA PRIMAVERA	125	80		•



GANASCE FRENO BRAKE SHOES

▶ 0161

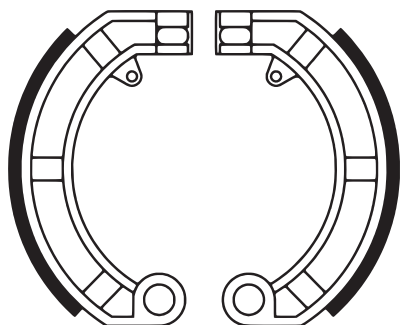

PIAGGIO	CC	MY	A	P
HP	50	92	•	•
VESPA	CC	MY	A	P
VESPA PK SPECIAL-XL	50			•
VESPA PK AUTOMATICA	125	86	•	•
VESPA PK SPECIAL-XL	125			•
VESPA PK XL 2	125			•
VESPA PX	125	98		•
VESPA PX	125			•
VESPA V FL2	125	90	•	•
VESPA PX	150	78	•	•
VESPA PX	150	98		•
VESPA SPRINT VELOCE	150			•
VESPA GS	160			•
VESPA SS	180			•
VESPA PE	200	83	•	•
VESPA PX	200	98		•
VESPA PX ARCOBALENO	200	83	•	•
VESPA RALLY	200	87		•

▶ 0162

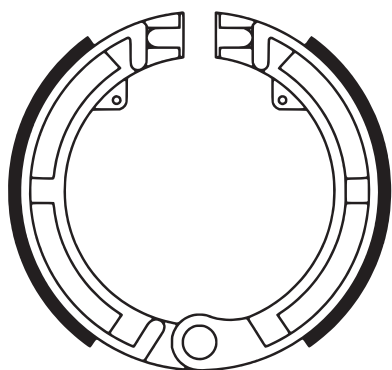

PIAGGIO	CC	MY	A	P
APE FL / FL2	50	89 95	•	
APE FL3 EUROPA	50	96 99	•	
APE RST MIX	50	99 05	•	
APE TL 2 SERIE	50		•	
VESPA	CC	MY	A	P
VESPA	50	63	•	
VESPA PK SPECIAL-XL	50		•	
VESPA SPECIAL	50		•	
VESPA PRIMAVERA	90		•	
VESPA	125	51 62	•	
VESPA	125	63 72	•	
VESPA ET3	125		•	
VESPA PRIMAVERA	125	80	•	
VESPA	150	51 62	•	
VESPA	150	63 72	•	
VESPA SUPER	150		•	

▶ 0187

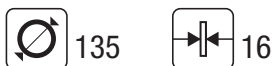
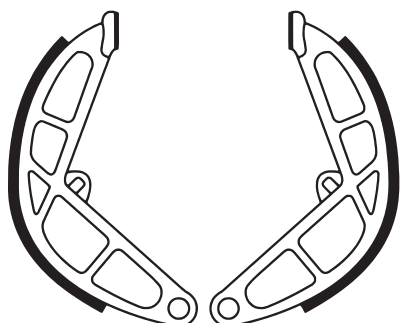

PIAGGIO	CC	MY	A	P
BOSS-GRILLO	50	89		•
CIAO-BRAVO-BOXER-SI	50			•

▶ 0266

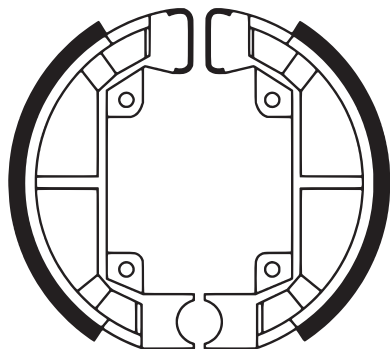

GILERA	CC	MY	A	P
EASY MOVING	50	96		•
NRG	50	93		•
STORM	50	94		•
TYPHOON	50	96	00	•
TYPHOON X	50	01		•
PIAGGIO	CC	MY	A	P
FREE (RUOTE IN LEGA)	50	96		•
QUARTZ	50	91	95	•
SFERA	50	90	95	•
ZIP	50	93	95	•
ZIP FAST RIDER	50	93		•
SFERA	80	94		•

▶ 0275

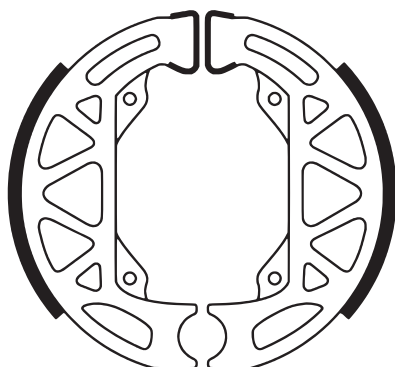

GILERA	CC	MY	A	P
NRG	50	96		•
NTT	50	96		•
PIAGGIO	CC	MY	A	P
FREE	50	96	00	•
NRG EXTREME ARIA	50	96	00	•
SFERA	50	96		•
SFERA RST	50	95		•
TYPHOON	50	94	97	•
TYPHOON X	50	98	00	•
ZIP FAST RIDER	50	93		•
ZIP RST	50	00		•
TYPHOON	80	96		•

▶ 0278

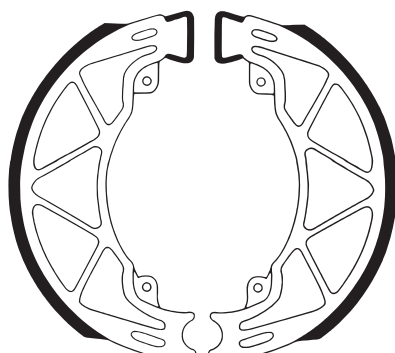

APRILIA	CC	MY	A	P
SCARABEO STREET	50	07		•
SCARABEO	100	03	07	•
MOJITO	150	99	05	•
SR	150	00		•
BENELLI	CC	MY	A	P
ADIVA	125	00		•
DERBI	CC	MY	A	P
BOULERVARD 4T	125	03		•
GILERA	CC	MY	A	P
RUNNER FXR (G)	180	00		•
RUNNER FXR (H)	180	00		•
RUNNER FX	200	97	98	•
ITALJET	CC	MY	A	P
DRAGSTER L.C.	125	99		•
JET-SET	125	02		•
TORPEDO 4T	125	99	02	•
DRAGSTER L.C.	180	99		•
PIAGGIO	CC	MY	A	P
HEXAGON LX (G)	125	98	99	•

HEXAGON LX (H)	125	98	99	•
LIBERTY 4T	125	97	99	•
LIBERTY 4T	125	00	07	•
LIBERTY S 4T	125	07		•
SKIPPER LX 2T (G)	125	98	99	•
SKIPPER LX 2T (H)	125	98	99	•
SKIPPER ST 4T (G)	125	00		•
SKIPPER ST 4T (H)	125	00		•
TYPHOON X	125	99	03	•
LIBERTY 4T	150	00		•
SKIPPER LXT 2T	150	98		•
HEXAGON LXT (G)	180	98	99	•
HEXAGON LXT (H)	180	98	99	•

GANASCE FRENO BRAKE SHOES

▶ 0280

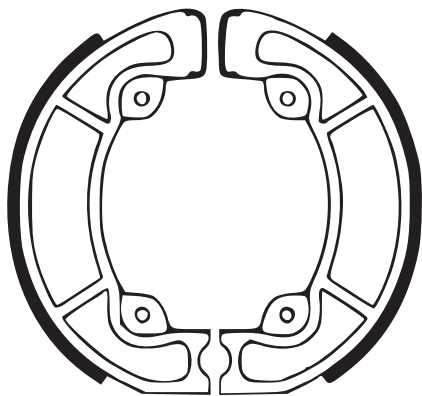

HONDA	CC	MY	A	P
DYLAN	125	01		•
PS I.	125	06		•
SH	125	01 08		•
SH I.	125	05 08		•
@	150	00		•
DYLAN	150	01		•
PS I.	150	06		•
SH	150	01 08		•
SH I.	150	05		•

▶ 0281

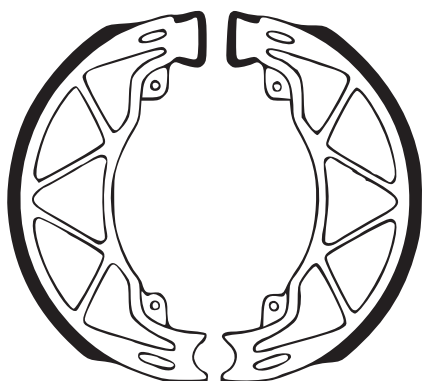

PIAGGIO	CC	MY	A	P
FLY (E.U.)	50	05		•
LIBERTY	50	97 07		•
LIBERTY 4T	50	00 07		•
LIBERTY S	50	08		•
LIBERTY S 4T	50	08		•
FLY	100	07		•
FREE	100	02		•

▶ 01200

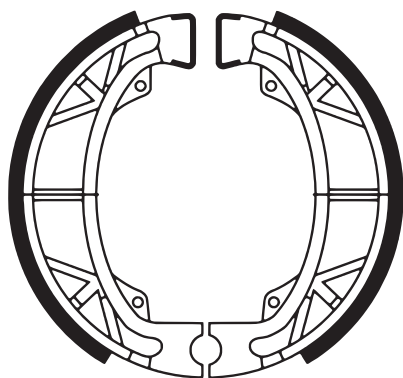

APRILIA	CC	MY	A	P
AMICO	50	90 91	•	•
AMICO SPORT LX	50	92		•
CLASSIC	50	96		•
GULLIVER	50	95 00		•
GULLIVER L.C.	50	96 00		•
RALLY	50	94 00		•
SCARABEO	50	94 95		•
SCARABEO	50	96 97		•
SCARABEO	50	98 02		•
SCARABEO	50	03		•
SONIC-SONIC G.P.	50	98		•
SR	50	93 00		•
SR EUROPA	50	94		•
SR REPLICA	50	92		•
SR REPLICA	50	93		•
SR URBAN	50	94		•
BENELLI	CC	MY	A	P
491 GT	50	98		•
491 SPORT	50	98		•
PEPE	50	99		•
BETA	CC	MY	A	P
ARK	50	96		•
CHRONO	50	94		•
TEMPO	50	98 02		•
TEMPO 13	50	94 97		•
CAGIVA	CC	MY	A	P
CITY	50	92 94		•
HONDA	CC	MY	A	P
MBX SD-SF-SH	50	83 87		•
TRX EX	90	07		•
TRX P/R/S/T/V/W/X/Y1-6	90	93 06		•
TRX ASTREA GRAND SUPRA	100	97 98		•
TRX ASTREA SUPRA NF	100	99		•

CB S-J	125	75 79	•	•
KYMCO	CC	MY	A	P
JAGER	50	01		•
MALAGUTI	CC	MY	A	P
CENTRO SL	50	94		•
CIAK	50	99		•
F 10	50	92		•
F 10	50	96		•
F 15 FIREFOX	50	97		•
YESTERDAY	50	98		•
CIAK	100	00		•
MOTRON	CC	MY	A	P
STING	50	95		•
THUNDER SC	50	95		•
PIAGGIO	CC	MY	A	P
TYPHOON	50	07 08		•
SYM	CC	MY	A	P
FIDDLE	50	99		•
JET	50	99		•
JUNGLE	50	99		•
MUSK L.C.	50	99		•
RED DEVIL	50	99		•
SUPER FANCY	50	99		•
JET	100	99		•
SUPER FANCY	100	99		•
ATTILA	125	99		•
SUPER DUKE	125	99		•
VILLA	CC	MY	A	P
GZ	50	93		•
YAMAHA	CC	MY	A	P
AXIS	50	94		•
JOG	50	92		•
JOG R	50	94		•

▶ 01205

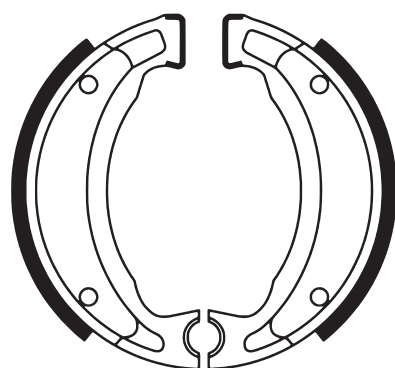

ADLY	CC	MY	A	P
FOX	50	07		•
JET	50	96		•
NOBLE/THUNDERBIKE	50	07		•
PANTHER	50	07		•
CPI	CC	MY	A	P
OLIVER CITY	50	08		•
OLIVER SPORT	50	08		•
FANTIC	CC	MY	A	P
PONY SR	50	92		•
QUEENIE	50	95		•
MBK	CC	MY	A	P
SORRISO	50	92		•
TARGET	50	92 94		•
FLAME	125	96 99		•
FLAME	125	00		•
YAMAHA	CC	MY	A	P
C3	50	07		•
CRZ	50	92		•
DT MX	50	92 95		•

DT R	50	97 01		•
NEO'S	50	97		•
SPY	50	95		•
TT-R	90	00 07		•
NEO'S	100	00		•
RT E/F/K	100	93 03		•
YB	100	82 86		•
YB	100	87 92		•
CYGNUS R	125	96 02		•
CYGNUS X	125	03		•
TT-R	125	00 07		•
TT-R L	125	00 07		•
YFM N	200	86 90		•
YFS B/F-H/J-N/P/R-T	200	91 02		•
XT	225	01 07		•
YFM DRN	225	85		•
YFM N/S/T/U	225	85 89		•

GANASCE FRENO BRAKE SHOES

► 01284

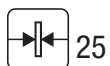
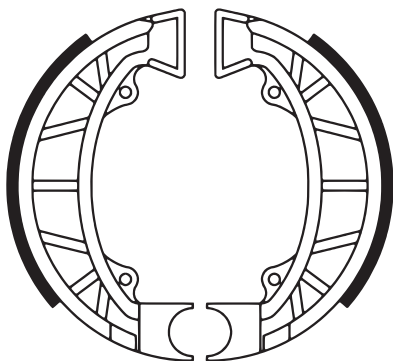

GILERA	CC	MY	A	P
ICE	50	01		•
RUNNER	50	97		•
RUNNER FX (G)	125	97 99		•
RUNNER FX (G)	125	00		•
RUNNER FX (H)	125	97 99		•
RUNNER FX (H)	125	00		•
TYPHOON	125	96		•
PIAGGIO	CC	MY	A	P
DIESIS	50	02		•
FREE	50	01		•
FREE	50	02		•
SFERA ET2	50	97		•
TYPHOON	50	01 03		•
TYPHOON SE	50	06		•
ZIP 4T KAT.	50	00		•
ZIP II	50	01		•
ZIP RST	50	96 99		•
ZIP SP L.C.	50	96 99		•
ZIP SP L.C.	50	00		•
ZIP	100	07		•

HEXAGON	125	94 97		•
SFERA	125	95		•
SFERA 4T	125	96		•
SKIPPER	125	93		•
SKIPPER LX	125	96 97		•
SKIPPER ST 4T (G)	125	00		•
SKIPPER ST 4T (H)	125	00		•
TYPHOON	125	96 98		•
ZIP 4T KAT.	125	00		•
HEXAGON	150	94 99		•
VESPA	CC	MY	A	P
VESPA ET2	50	99		•
VESPA ET4 (G)	50	01		•
VESPA ET4 (H)	50	01		•
VESPA LX 2T	50	05		•
VESPA LX 4T	50	05		•
VESPA ET4	125	97 99		•
VESPA ET4	125	00		•
VESPA LX	125	05 07		•
VESPA LX	150	05 07		•
VESPA LXV	150	05 08		•

Dischi Freno

I dischi freno ADIGE® sono realizzati in uno speciale acciaio inox ad alto contenuto di carbonio e realizzati da taglio laser. Garantiscono una frenata potente, grande resistenza all'usura ed elevata sicurezza. Tutte le superfici non lavorate vengono verniciate in cataforesi nera per prevenire qualsiasi innesco di ossidazione. Studiati e progettati per un uso specifico su scooter e maxi-scooter i dischi freno ADIGE® sono perfettamente compatibili con il prodotto originale.

Brake Discs

ADIGE® brake discs are laser cut from sheets of special stainless steel with a high percentage of carbon. The discs assure a powerful braking process, high resistance to wear and high safety. All the surfaces that are not machined are painted in black cataphoresis to prevent every oxidation trigger. The discs are designed and developed for specific use on scooters and maxi-scooters. The ADIGE® brake discs are perfectly compatible with the stock brake discs.



TONDO – FISSO:

Caratteristiche:

- Disco in acciaio ad alto contenuto di carbonio
- Pista frenante forata
- Peso contenuto
- Perfettamente sostituibile all'originale

ROUND – FIX:

Features:

- *Stainless steel with high content of carbon*
- *External track with holes*
- *Low weight*
- *Perfectly interchangeable with the stock brake disc*

WAVE™ – FLOTTANTE:

Caratteristiche:

- Disco in acciaio ad alto contenuto di carbonio
- Forte grip iniziale con buona modulabilità
- Appoggio costante su tre punti, con usura parallela della pastiglia
- Superficie periferica superiore con una maggiore dissipazione del calore
- Minor tendenza alle deformazioni
- Minor peso
- Perfettamente sostituibile all'originale

WAVE™ – FLOATING:

Features:

- *Stainless steel with high content of carbon*
- *External track with non-round profile*
- *High initial grip that can be modulated*
- *Uniform three point support, resulting in a parallel wear of the brake pads*
- *Bigger peripheral surface for a better heat dissipation*
- *Lower deformation*
- *Lower weight*
- *Perfectly interchangeable with the stock brake disc*



▶ DF-1

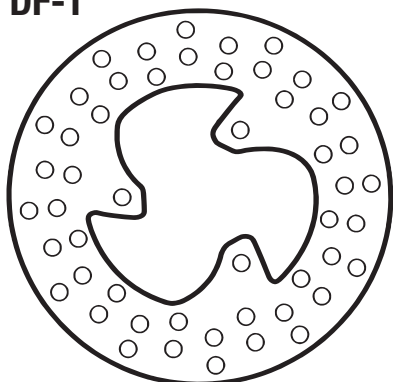

190.0 58.0 3.8
 spessore minimo diametro fori
 min. thickness holes diameter
 3.3 8.5
 numero fori interasse fori
 number of holes bolt pattern
 3 80

APRILIA	CC	MY	A	P
AREA 51	50	98 99	DX	
AREA 51 SBK	50	00 02	DX	
GULLIVER	50	95 00	SX	
GULLIVER L.C.	50	96 00	SX	
HABANA	50	98 05	SX	
MOJITO	50	99 05	SX	
RALLY	50	94 00	SX	
RALLY L.C.	50	97	SX	SX
SCARABEO D-TECH	50	02 06	SX	
SCARABEO DE LUXE	50	98 01	SX	
SR	50	93 00	SX	
SR D-TECH	50	01	SX	SX
SR EUROPA	50	94	SX	
SR R	50	05	SX	DX
SR R FACTORY	50	05 06	SX	
SR RACING KAT.	50	00	SX	DX
SR REPLICA	50	92	SX	
SR REPLICA	50	93	SX	
SR STEALTH L.C.	50	97	SX	DX
SR STREET	50	07	SX	SX
SR URBAN	50	94	SX	
SR WWW	50	97	SX	
LEONARDO	125	96 98	DX	
LEONARDO 4T	150	98	SX	
LEONARDO 4T	150	99 04	SX	
SR	150	00	SX	
BETA	CC	MY	A	P
ARK L.C.	50	97	SX	SX
CHRONO	50	94	SX	

TEMPO	50	98 02	SX	
TEMPO 13	50	94 97	SX	
GILERA	CC	MY	A	P
NRG	50	93	SX	
NRG	50	96	SX	
NRG-MC2	50	99 00	SX	
NTT	50	94	SX	
NTT	50	96	SX	
STALKER DD	50	99	SX	
TYPHOON	50	96 00	SX	
TYPHOON X	50	01	SX	
TYPHOON	125	96	SX	
HUSQVARNA	CC	MY	A	P
WRS	50	98 00	SX	
MBK	CC	MY	A	P
OVETTO	50	98	SX	
OVETTO	100	00	SX	
PIAGGIO	CC	MY	A	P
NRG EXTREME	50	01	SX	
NRG EXTREME ACQUA	50	96 00	SX	
NRG EXTREME ARIA	50	96 00	SX	
NTT	50	95	SX	
TYPHOON	50	94 97	SX	
TYPHOON X	50	98 00	SX	
TYPHOON SE	50	06	SX	
TYPHOON	80	96	SX	
TYPHOON	125	96 98	SX	
TYPHOON X	125	99 03	SX	
YAMAHA	CC	MY	A	P
NEO'S	100	00	SX	

▶ DF-2

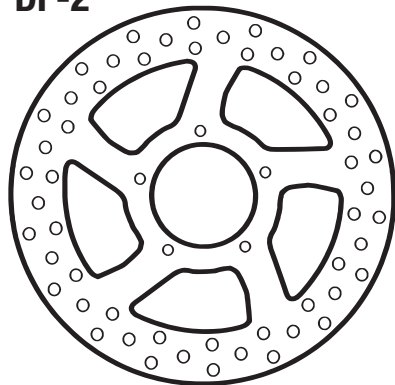

220.0 60.0 4.0
 spessore minimo diametro fori
 min. thickness holes diameter
 3.5 8.5
 numero fori interasse fori
 number of holes bolt pattern
 5 80

APRILIA	CC	MY	A	P
SCARABEO	50	98 02	SX	
SCARABEO	50	03	SX	
SCARABEO	100	00 02	SX	
SCARABEO	100	03 07	SX	
LEONARDO	125	96 98	SX	
LEONARDO	125	99 06	SX	
SCARABEO	125	98 03	SX	
SCARABEO GT	125	04 06	SX	
SPORTCITY	125	05	SX	
LEONARDO 4T	150	98	SX	
LEONARDO 4T	150	99 04	SX	
SCARABEO GT	150	04 06	SX	
SCARABEO	200	07	SX	
SCARABEO	200	01 02	SX	
SCARABEO GT	200	03 06	SX	
SPORTCITY	200	05 06	SX	
LEONARDO	250	99 00	SX	
LEONARDO	250	01 04	SX	
SPORTCITY I.E.	250	07	SX	
ATLANTIC SPRINT	500	05 07	SX	

SCARABEO ABS	500	03 06	SX	
BETA	CC	MY	A	P
EIKON	150	00 05	SX	

DISCHI FRENO BRAKE DISKS

DF-3

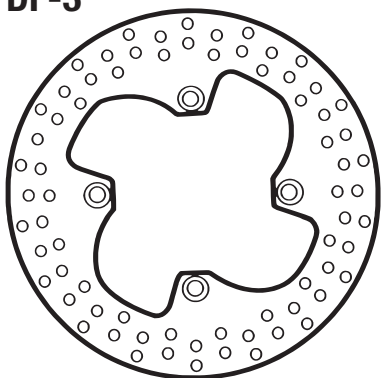

spessore minimo
min. thickness 4.5 diametro fori
holes diameter 10.5
numero fori
number of holes 4 interasse fori
bolt pattern 125

HONDA	CC	MY	A	P
PANTHEON	125	98 99	SX	
PANTHEON	125	00 02	SX	
PANTHEON	125	03	SX	
SH	125	09		
PANTHEON	150	98 02	SX	
PANTHEON	150	03	SX	
SH	150	09		

DF-4

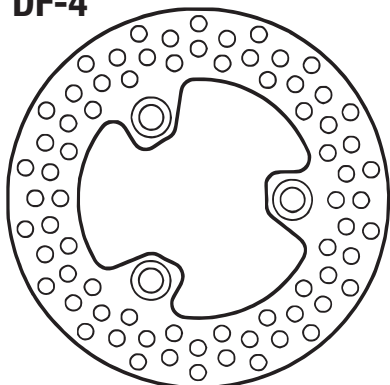

spessore minimo
min. thickness 3.0 diametro fori
holes diameter 10.5
numero fori
number of holes 3 interasse fori
bolt pattern 80

CAGIVA	CC	MY	A	P
CITY	50	92 94	SX	
PASSING	50	95	SX	
PASSING	125	94	SX	
HONDA	CC	MY	A	P
DIO SCOOTER	50	91	SX	
DIO ZX	50	94	SX	
GP DIO	50	92	SX	
ZX SCOOTER	50	94	SX	
KYMCO	CC	MY	A	P
DJX	50	94	SX	
FEVER ZX	50	97	SX	
HEROISM	50	95	SX	
K 12	50	95	SX	
K B	50	95	SX	
SNIPER DD	50	94	SX	
ZX	50	05	SX	
HEROISM	125	95	SX	
HEROISM	150	95	SX	

DF-5

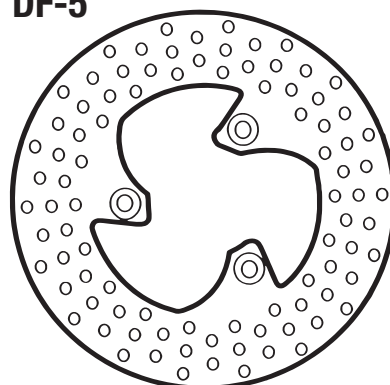

spessore minimo
min. thickness 2.7 diametro fori
holes diameter 10.5
numero fori
number of holes 3 interasse fori
bolt pattern 80

HONDA	CC	MY	A	P
BALI	50	93	SX	
SKY	50	97	SX	
BALI	100	99	SX	
MBK	CC	MY	A	P
BOOSTER N.G.	50	99	SX	
NITRO	50	97	SX	SX
STUNT	50	00	SX	
NITRO	100	00	SX	
PGO	CC	MY	A	P
PMS	50	99	SX	
T REX	50	99	SX	
PMS	110	99	SX	
T REX	110	99	SX	
YAMAHA	CC	MY	A	P
AEROX	50	97	SX	DX
SLIDER	50	00	SX	
AEROX	100	00	SX	DX

▶ DF-6

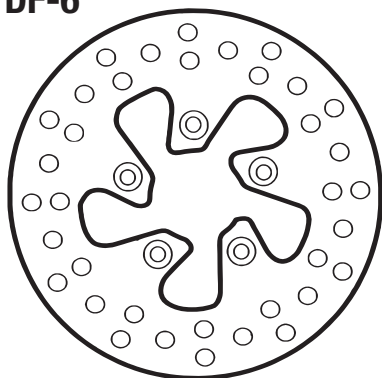

155.0 39.0 3.0
 spessore minimo 2.5 diametro fori 6.5
 min. thickness holes diameter
 numero fori 5 interasse fori 60
 number of holes bolt pattern

MALAGUTI	CC	MY	A	P
F 10	50	92	SX	
F 10	50	96	SX	
MOTRON	CC	MY	A	P
STING	50	95	SX	
PEUGEOT	CC	MY	A	P
LUDIX BULLET	50	04	SX	
LUDIX SNAKE	50	04	SX	
LUDIX TREND	50	04	SX	
ZENITH	50	94 95	SX	
ZENITH	50	96	SX	

▶ DF-7

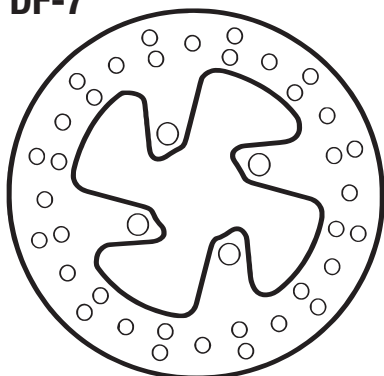

180.0 48.0 3.5
 spessore minimo 3.0 diametro fori 10.5
 min. thickness holes diameter
 numero fori 4 interasse fori 66
 number of holes bolt pattern

MBK	CC	MY	A	P
BOOSTER N.G.	50	95 98	SX	
BOOSTER SPIRIT	50	99	SX	
BOOSTER	100	99	SX	
BOOSTER	100	00	SX	
YAMAHA	CC	MY	A	P
BW'S BUMP	50	96	SX	
BW'S SPY	50	96	SX	
SPY	50	95	SX	

DISCHI FRENO BRAKE DISKS

DF-8

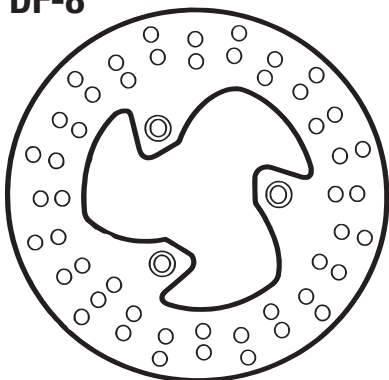

spessore minimo
min. thickness **3.3** diametro fori
holes diameter **8.5**
numero fori
number of holes **3** interasse fori
bolt pattern **80**

BENELLI	CC	MY	A	P
491 GT	50	98	SX	
491 NAKED	50	98	SX	
491 SPORT	50	98	SX	
491 SUPERBIKE-491 R	50	98	SX	SX
K 2	50	98	SX	
K 2 LIQUIDO	50	98	SX	SX
K 2	100	99	SX	
VELVET	250	98 00	SX	
VELVET	250	01 07	SX	
BETA	CC	MY	A	P
EIKON	50	99 06	SX	SX
QUADRA	50	97 01	SX	
MALAGUTI	CC	MY	A	P
CROSSER	50	99	SX	
F 12 PHANTHOM	50	94	SX	
F 12 PHANTHOM	50	98	SX	
F 12 PHANTHOM	50	99	DX	
F 15 FIREFOX	50	97	SX	
F 15 FIREFOX L.C.	50	99	SX	
F 12 PHANTHOM	100	00	DX	
F 18 WARRIOR	125	00 03	SX	

MOTRON	CC	MY	A	P
THUNDER SC	50	95	SX	
PEUGEOT	CC	MY	A	P
BUXY RS	50	94	SX	
ELISEO	50	98 02	SX	
ELISEO	50	03	SX	
FOX	50	95	SX	
JET FORCE	50	03	SX	
LUDIX ELEGANCE	50	04	SX	
SPEEDAKE	50	95	SX	
SPEEDFIGHT H2O	50	97	SX	
SQUAB	50	95	SX	
SV GEO	50	92	SX	
SV GEO	50	93	SX	
TREKKER OFF ROAD	50	97	SX	
TREKKER ROAD	50	97	SX	
VIVACITY	50	99	SX	
SV GEO	80	91	SX	
TREKKER ROAD	100	98	SX	
VIVACITY	100	99	SX	
SV GEO	125	92	SX	
SV GEO	125	95	SX	

DF-9

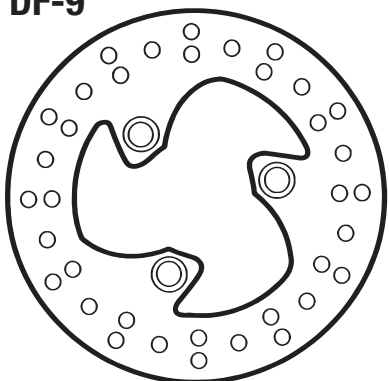

spessore minimo
min. thickness **3.0** diametro fori
holes diameter **11.7**
numero fori
number of holes **3** interasse fori
bolt pattern **80**

PEUGEOT	CC	MY	A	P
SPEEDFIGHT	50	96	SX	
SPEEDFIGHT ARIA	50	97	SX	
SPEEDFIGHT H2O	50	97	DX	
SPEEDFIGHT	80	96	DX	
SPEEDFIGHT	100	97	SX	DX

▶ DF-10

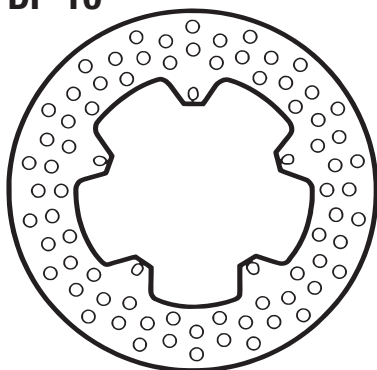

spessore minimo
min. thickness **3.5** diametro fori
holes diameter **6.5x8**

numero fori
number of holes **5** interasse fori
bolt pattern **108.5**

GILERA	CC	MY	A	P
DNA L.C. (G)	50	00 02	SX	
DNA L.C. (H)	50	00	SX	
RUNNER VX (G)	125	01	SX	
RUNNER VX (H)	125	01	SX	
MALAGUTI	CC	MY	A	P
CENTRO SL	50	94	DX	
PIAGGIO	CC	MY	A	P
FREE	50	96 00	DX	
FREE	50	01	DX	
FREE	50	02	DX	
QUARTZ	50	91 95	SX	
SFERA	50	96	SX	
SFERA ET2	50	97	SX	
ZIP RST	50	96 99	SX	
ZIP RST	50	00	SX	
ZIP SP L.C.	50	96 99	SX	
SKIPPER	80	94	SX	
HEXAGON GTX (G)	125	00	SX	DX
HEXAGON GTX (H)	125	00	SX	DX
HEXAGON LX (G)	125	98 99	SX	

HEXAGON LX (H)	125	98 99	SX	
SFERA 4T	125	96	SX	
SKIPPER	125	93	SX	
SKIPPER LX	125	96 97	SX	
SUPERHEXAGON GTX (H)	125	01	SX	DX
ZIP 4T KAT.	125	00	SX	
HEXAGON	180	00	SX	DX
HEXAGON LXT (G)	180	98 99	SX	
HEXAGON LXT (H)	180	98 99	SX	
HEXAGON GT 4T (G)	250	98 99	SX	
HEXAGON GTX (G)	250	00	SX	DX
HEXAGON GTX (H)	250	00	SX	DX
VESPA	CC	MY	A	P
VESPA ET2	50	99	SX	
VESPA ET4 (G)	50	01	SX	
VESPA ET4 (H)	50	01	SX	
VESPA ET4	125	97 99	SX	
VESPA ET4	125	00	SX	
VESPA ET4	150	99	SX	
VESPA PX	150	98	DX	
VESPA PX	200	98	SX	

▶ DF-11

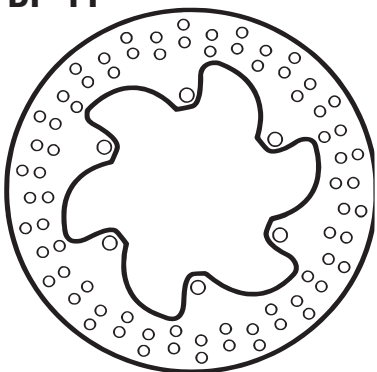

spessore minimo
min. thickness **3.5** diametro fori
holes diameter **8.5**

numero fori
number of holes **6** interasse fori
bolt pattern **133**

MBK	CC	MY	A	P
SKYLINER	250	00	DX	
SKYLINER	250	01	DX	
YAMAHA	CC	MY	A	P
MAJESTY DE-LUXE	250	98 00	DX	
MAJESTY YP	250	01 03	DX	

DISCHI FRENO BRAKE DISKS

▶ DF-12

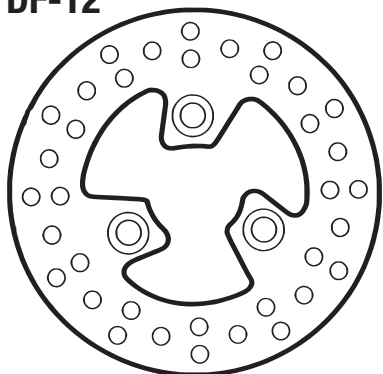

155.0



41.0



3.5

spessore minimo
min. thickness 3.0 diametro fori
holes diameter 10.5
numero fori
number of holes 3 interasse fori
bolt pattern 66

APRILIA	CC	MY	A	P
AMICO SPORT LX	50	92		SX
SONIC-SONIC G.P.	50	98		SX
FANTIC	CC	MY	A	P
BIG WHEELS	50	91		SX
BIP RACING	50	94		SX
GRINTA	50	97		SX
PONY SR	50	92		SX
QUEENIE	50	95		SX
GILERA	CC	MY	A	P
EASY MOVING	50	96		SX
ITALJET	CC	MY	A	P
BAZOOKA 2	50	92	97	SX
PISTA	50	92		SX
YANKEE 8	50	94		SX
MBK	CC	MY	A	P
BOOSTER R	50	93	95	SX
BOOSTER SPIRIT	50	95	98	SX
FIZZ	50	94		SX
FORTE	50	94		SX
TARGET	50	92	94	SX

PGO	CC	MY	A	P
BIG MAX	50	95		SX
HOT	50	98		SX
PMX	50	99		SX
TORNADO	50	96		SX
VILLA	CC	MY	A	P
GZ	50	93		SX
YAMAHA	CC	MY	A	P
AXIS	50	94		SX
BREEZE	50	95		SX
CRZ	50	92		SX

▶ DF-13

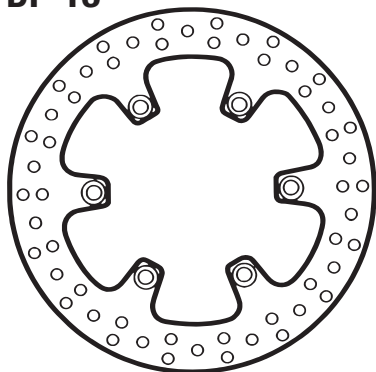

260.0



121.0



5.0

spessore minimo
min. thickness 3.5 diametro fori
holes diameter 10.5
numero fori
number of holes 6 interasse fori
bolt pattern 142

SUZUKI	CC	MY	A	P
AN BURGMAN	250	98	03	SX
AN BURGMAN BUSINESS	250	01	02	SX

▶ DF-14

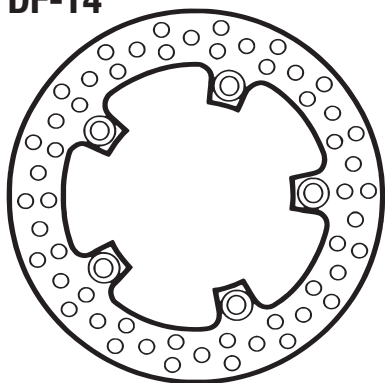

spessore minimo 4.5 diametro fori 10.5
min. thickness holes diameter

numero fori 5 interasse fori 132
number of holes bolt pattern

SUZUKI	CC	MY	A	P
AN BURGMAN	250	98 03	DX	
AN BURGMAN BUSINESS	250	01 02	DX	

▶ DF-15

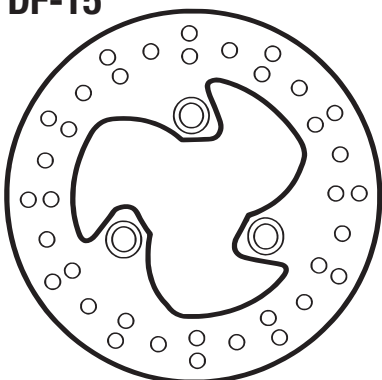

spessore minimo 3.3 diametro fori 10.5
min. thickness holes diameter

numero fori 3 interasse fori 80
number of holes bolt pattern

KYMCO	CC	MY	A	P
AGILITY	50	05	SX	
TOP BOY	50	97	SX	
YUP	50	01	SX	
DINK	125	97	DX	SX
DINK LX	125	99	DX	SX
DINK	150	97	DX	SX
DINK LX	150	99	DX	SX

▶ DF-16

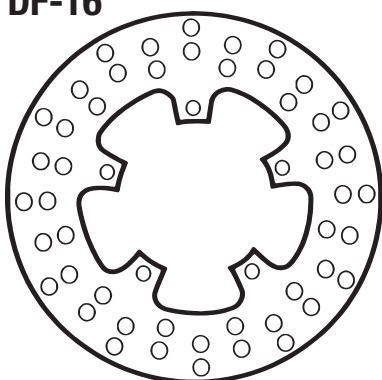

spessore minimo 3.5 diametro fori 6.5
min. thickness holes diameter

numero fori 5 interasse fori 86
number of holes bolt pattern

GILERA	CC	MY	A	P
NRG-MC2	50	99 00	SX	
RUNNER DD	50	97	SX	
RUNNER SP	50	01 04	SX	
RUNNER SP	50	05	SX	
STALKER DD	50	99	SX	

DISCHI FRENO BRAKE DISKS

▶ DF-18

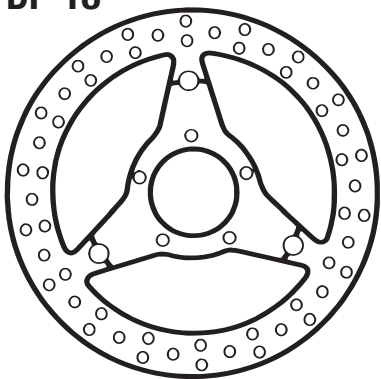

spessore minimo
min. thickness 4.5 diametro fori
holes diameter 8.5
numero fori
number of holes 3 interasse fori
bolt pattern 80

APRILIA	CC	MY	A	P
SCARABEO	125	98 03	SX	
SPORTCITY	125	05	SX	
SCARABEO	150	98 03	SX	
SCARABEO GT	150	04 06	SX	
SCARABEO	200	07	SX	
SCARABEO	200	01 02	SX	
SCARABEO GT	200	03 06	SX	
SPORTCITY	200	05 06	SX	
SCARABEO	250	04 05	SX	
SCARABEO	250	06	SX	
SCARABEO I.E.	250	07	SX	
SPORTCITY I.E.	250	07	SX-DX	
SCARABEO I.E.	400	07	SX-DX	
ATLANTIC	500	02 04	SX-DX	
ATLANTIC SPRINT	500	05 07	SX-DX	
SCARABEO ABS	500	03 06	SX-DX	
SCARABEO I.E.	500	07	SX-DX	

▶ DF-19

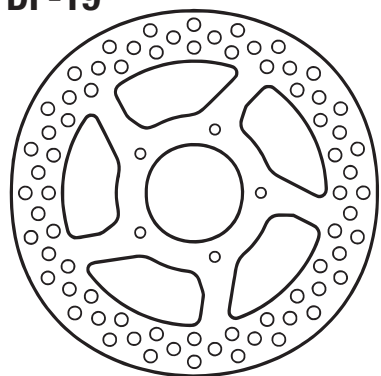

spessore minimo
min. thickness 2.5 diametro fori
holes diameter 6.5
numero fori
number of holes 5 interasse fori
bolt pattern 80

BENELLI	CC	MY	A	P
ADIVA	125	00	SX	
ADIVA	150	00	SX	
GILERA	CC	MY	A	P
RUNNER	50	97	SX	
RUNNER SP	50	01 04	SX	
RUNNER FX (G)	125	97 99	SX	
RUNNER FX (G)	125	00	SX	
RUNNER FX (H)	125	97 99	SX	
RUNNER FX (H)	125	00	SX	
RUNNER SP	125	98 00	SX	
RUNNER SP	125	01	SX	
RUNNER VX (G)	125	01	SX	
RUNNER FXR (G)	180	00	SX	
RUNNER FXR (H)	180	00	SX	
RUNNER FXR SP (G)	180	99	SX	
RUNNER FXR SP (H)	180	99	SX	SX
RUNNER VXR 4T (H)	180	01	SX	
PIAGGIO	CC	MY	A	P
NRG=MC2	50	99	SX	
SKIPPER LX 2T (G)	125	98 99	SX	

SKIPPER LX 2T (H)	125	98 99	SX	
SKIPPER ST 4T (H)	125	00	SX	
SKIPPER LXT 2T	150	98	SX	

▶ DF-20

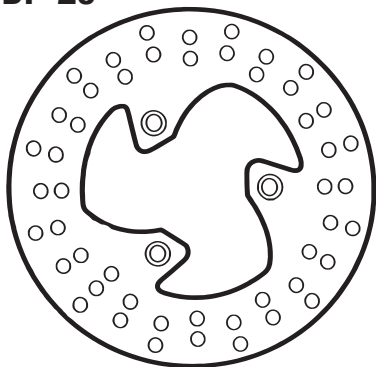

spessore minimo 2.5 diametro fori 8.5
min. thickness
numero fori 3 interasse fori 80
number of holes bolt pattern

MALAGUTI	CC	MY	A	P
F 12 PHANTHOM	50	99	SX	
F 15 FIREFOX L.C.	50	99	SX	
F 12 PHANTHOM	100	00	SX	

▶ DF-22

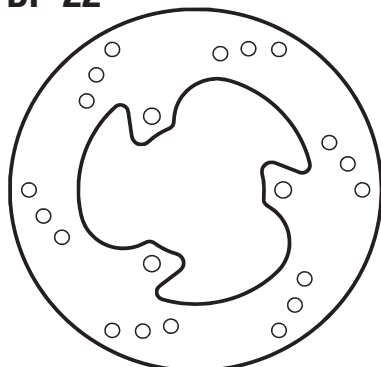

spessore minimo 4.0 diametro fori 8.5
min. thickness
numero fori 3 interasse fori 89.5
number of holes bolt pattern

APRILIA	CC	MY	A	P
SR R FACTORY	50	05 06	SX	
ATLANTIC	125	03 06	SX	
ATLANTIC	125	07	SX	
ATLANTIC	200	03 04	SX	
ATLANTIC	200	05	SX	
ATLANTIC	250	05 06	SX	

▶ DF-23

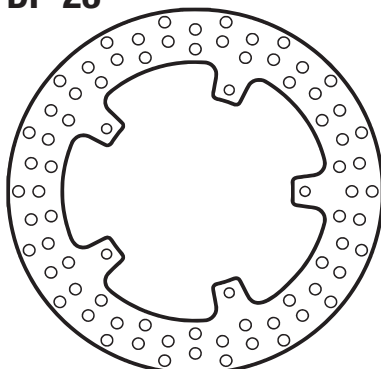

spessore minimo 3.5 diametro fori 6.5
min. thickness
numero fori 5 interasse fori 140.5
number of holes bolt pattern

GILERA	CC	MY	A	P
DNA L.C. (G)	50	00 02	SX	
DNA L.C. (H)	50	00	SX	
DNA 4T (G)	125	01 02	SX	SX
DNA 4T (H)	125	01 03	SX	SX
RUNNER FX (G)	125	00	SX	
RUNNER FX (H)	125	00	SX	
RUNNER SP	125	98 00	SX	
RUNNER SP	125	01	SX	
DNA 4T (G)	180	01	SX	
DNA 4T (H)	180	01	SX	SX
RUNNER FXR (G)	180	00	SX	
RUNNER FXR (H)	180	00	SX	
RUNNER FXR SP (G)	180	99	SX	

ITALJET	CC	MY	A	P
DRAGSTER L.C.	125	99	SX	
DRAGSTER L.C.	125	00 03	SX	
DRAGSTER L.C.	180	00 03	SX	

DF-24

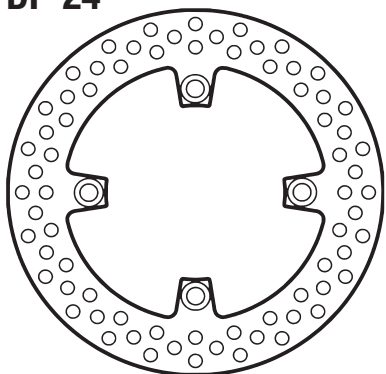

spessore minimo
min. thickness 3.5 diametro fori
holes diameter 10.5

numero fori
number of holes 4 interasse fori
bolt pattern 125

HONDA	CC	MY	A	P
@	125	00	SX	
DYLAN	125	01	SX	
PS I.	125	06	SX	
SH	125	01 08	SX	
SH I.	125	05 08	SX	
@	150	00	SX	
DYLAN	150	01	SX	
PS I.	150	06	SX	
SH	150	01 08	SX	
SH I.	150	05	SX	

DF-25

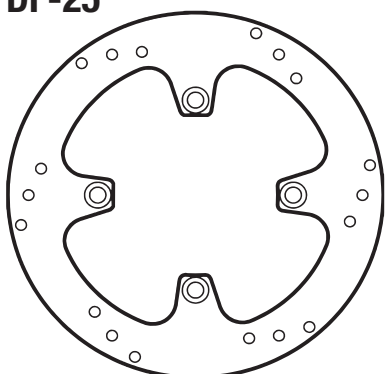

spessore minimo
min. thickness 3.5 diametro fori
holes diameter 10.5

numero fori
number of holes 4 interasse fori
bolt pattern 125

HONDA	CC	MY	A	P
FORESIGHT	250	01	SX	
FORZA	250	00 04	SX	
FORZA X - Z	250	05	SX	
JAZZ	250	01	SX	

PEUGEOT	CC	MY	A	P
SV	250	03	SX	
SV	250	01 02	SX	

DF-26

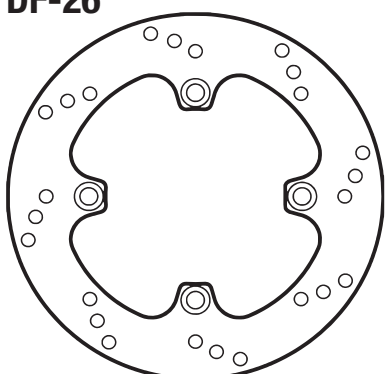

spessore minimo
min. thickness 4.5 diametro fori
holes diameter 10.5

numero fori
number of holes 4 interasse fori
bolt pattern 125

HONDA	CC	MY	A	P
PANTHEON	125	03	DX	
PANTHEON	150	03	DX	
FORESIGHT	250	01	DX	
FORZA	250	00 04	DX	
JAZZ	250	01	SX	

▶ DF-27

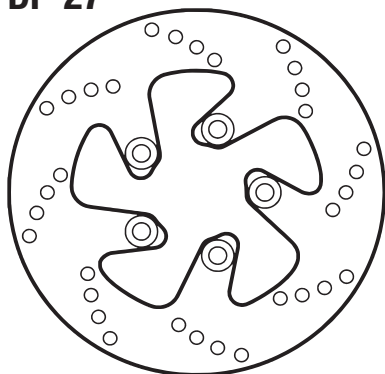

spessore minimo 3.5 diametro fori 10.5
min. thickness holes diameter

numero fori 5 interasse fori 80
number of holes bolt pattern

KYMCO	CC	MY	A	P
BET & WIN	50	01	DX	
MOVIE XL	150	99	DX	
BET & WIN 4T	250	00	DX	
GRAND DINK	250	02	DX	
GRANDVISTA	250	08	DX	

▶ DF-28

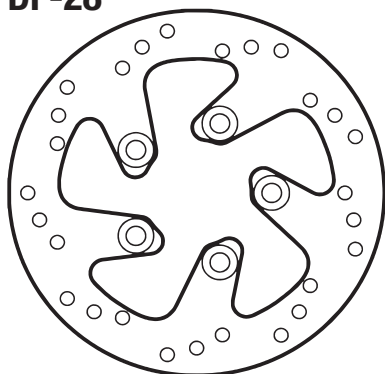

spessore minimo 3.5 diametro fori 10.5
min. thickness holes diameter

numero fori 5 interasse fori 80
number of holes bolt pattern

KYMCO	CC	MY	A	P
GRAND DINK	125	02	DX	
BET & WIN 4T	250	00	DX	
GRAND DINK	250	02	DX	
GRANDVISTA	250	08	DX	
YUP	250	02	DX	

▶ DF-29

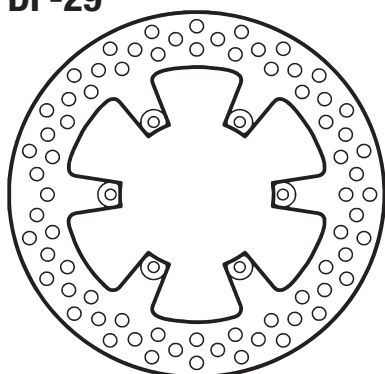

spessore minimo 3.5 diametro fori 6.5
min. thickness holes diameter

numero fori 6 interasse fori 101
number of holes bolt pattern

MALAGUTI	CC	MY	A	P
F 12 PHANTHOM MAX	125	04	SX	SX
MADISON R	125	06	SX	DX
MADISON	150	99	SX	DX
MADISON	180	01	SX	DX
MADISON	250	99	00	DX
MADISON	250	01	04	DX
MADISON RS	250	05	DX	

DISCHI FRENO BRAKE DISKS

▶ DF-30

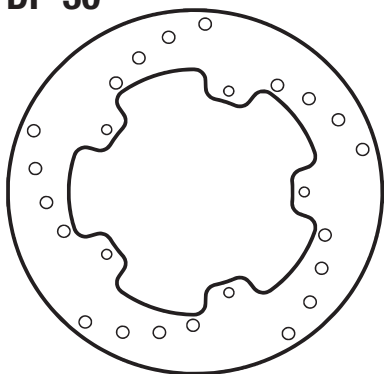

	240.0		125.2		5.0
spessore minimo min. thickness		4.5	diametro fori holes diameter		6.5
numero fori number of holes		5	interasse fori bolt pattern		140

GILERA	CC	MY	A	P
NEXUS I.E.	250	06	SX	
NEXUS	500	04	SX	
NEXUS I.E.	500	06	SX	
HONDA	CC	MY	A	P
FORZA EX	250	05 06	DX	
FORZA X - Z	250	05	DX	
PIAGGIO	CC	MY	A	P
X 8 I.E.	125	07	DX	
X 9 EVOLUTION	125	06	SX	SX
X 8	180	07	DX	
X 9 AMALFI	180	00 03	SX	SX
X 9 AMALFI	200	01 02	SX-DX	SX
X 9	250	00 04	SX-DX	SX
BEVERLY I.E.	400	07	SX	
BEVERLY B 4T	500	02 05	DX	
BEVERLY I.E.	500	07	DX	
X 9	500	00 02	DX	

▶ DF-31

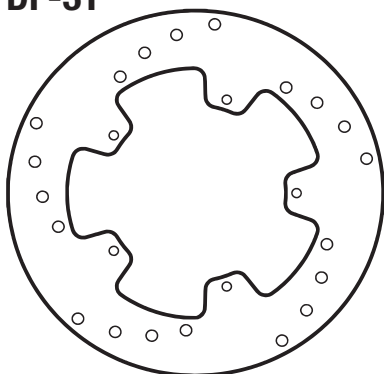

	260.0		125.2		4.0
spessore minimo min. thickness		3.5	diametro fori holes diameter		6.5
numero fori number of holes		5	interasse fori bolt pattern		140

GILERA	CC	MY	A	P
NEXUS I.E.	250	06	SX	
NEXUS	500	04	SX-DX	
NEXUS I.E.	500	06	SX-DX	
PIAGGIO	CC	MY	A	P
BEVERLY	125	07	SX	SX
BEVERLY B 4T (G)	125	02 06	SX	SX
BEVERLY B 4T (H)	125	02 06	SX	SX
BEVERLY S	125	07	SX	SX
X 8 4T	125	04 05	SX	
X 8 4T	125	05 06	SX	
X 8 I.E.	125	07	SX	
X 8	180	07	SX	
LIBERTY 4T	200	05	SX	
X 8 4T	200	04 05	SX	
BEVERLY 4T	250	04	SX	SX
BEVERLY I.E.	250	07	SX	SX
BEVERLY S I.E.	250	07	SX	SX
BEVERLY I.E.	400	07	SX	
BEVERLY	500	06	SX-DX	
BEVERLY B 4T	500	02 05	SX-DX	
X 9 EVOLUTION ABS	500	03 06	SX-DX	
X 9 I.E.	500	07	SX-DX	

▶ DF-32

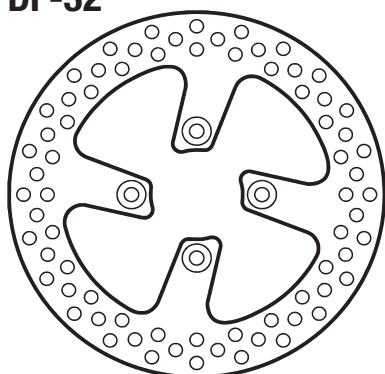

spessore minimo 3.5 diametro fori 8.5
min. thickness holes diameter
numero fori 4 interasse fori 76.5
number of holes bolt pattern

MBK	CC	MY	A	P
SKYLINER	125	99	SX	
SKYLINER	125	02	SX	
SKYLINER	150	00	SX	
SKYLINER	180	03	SX	
YAMAHA	CC	MY	A	P
MAJESTY SP	125	98 00	SX	
MAJESTY SP	125	01	SX	
MAJESTY 4T	150	99	SX	
MAJESTY SP	180	03	SX	

▶ DF-33

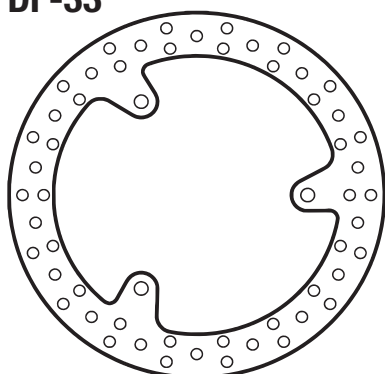

spessore minimo 4.5 diametro fori 8.5
min. thickness holes diameter
numero fori 3 interasse fori 136
number of holes bolt pattern

MBK	CC	MY	A	P
SKYLINER	250	00	DX	
SKYLINER	250	01	DX	
YAMAHA	CC	MY	A	P
MAJESTY YP	250	01 03	DX	

▶ DF-34

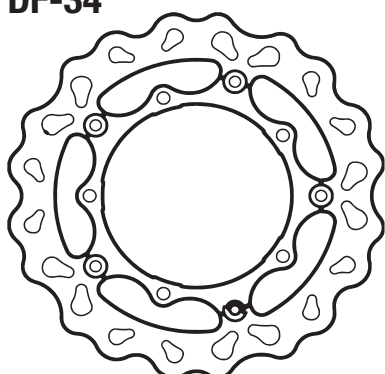





spessore minimo 3.5 diametro fori 9
min. thickness holes diameter
numero fori 5 interasse fori 150
number of holes bolt pattern

YAMAHA	CC	MY	A	P
MAJESTY S / T	400	04	SX	

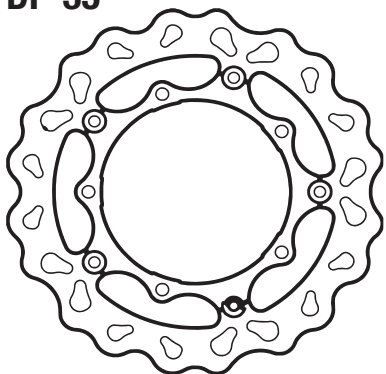
DISCHI FRENO BRAKE DISKS

▶ DF-35





 267.0	 132.0	 4.0
spessore minimo min. thickness 3.5	diametro fori holes diameter 9	
numero fori number of holes 5	interasse fori bolt pattern 150	

YAMAHA	CC	MY	A	P
X-MAX	125	06	DX	
X-MAX	250	04 09	DX	

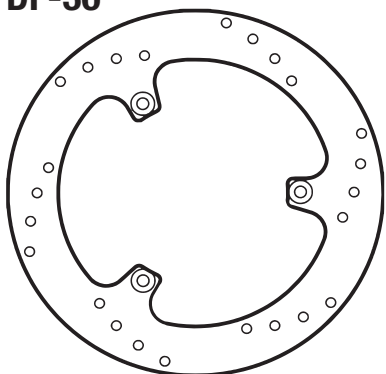
▶ DF-36





 268.0	 132.0	 5.0
spessore minimo min. thickness 4.5	diametro fori holes diameter 8.5	
numero fori number of holes 3	interasse fori bolt pattern 150	

YAMAHA	CC	MY	A	P
MAJESTY YP	250	04	DX	
MAJESTY S / T	400	04	DX	
MAJESTY T / V / W	400	05	DX	

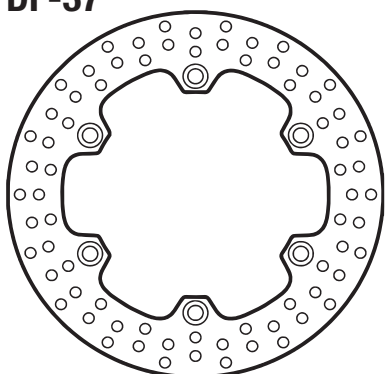
▶ DF-37



 256.0	 144.0	 5.0
spessore minimo min. thickness 4.5	diametro fori holes diameter 10.5	
numero fori number of holes 6	interasse fori bolt pattern 166	

HONDA	CC	MY	A	P
SH I.E.	300	06	SX	DX
SILVER WING	400	06	SX	
SILVER WING	600	01	SX	
SILVER WING ABS	600	01	SX	

▶ DF-38

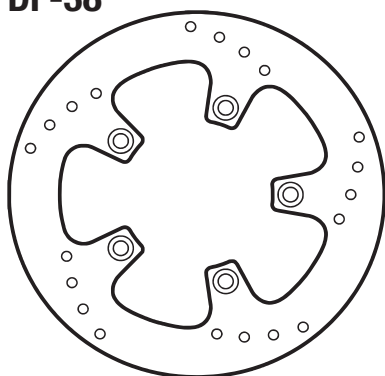

spessore minimo 4.5 diametro fori 10.5
min. thickness holes diameter

numero fori 5 interasse fori 130
number of holes bolt pattern

KYMC0	CC	MY	A	P
XCITING 250	250	05	SX-DX	
XCITING 500	500	05	SX-DX	

▶ DF-39

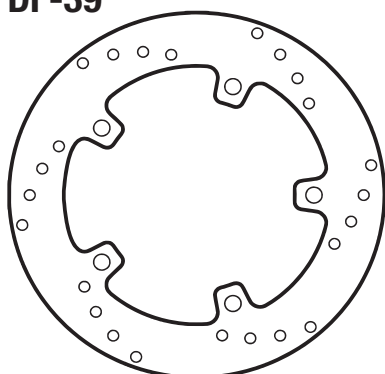

spessore minimo 4.5 diametro fori 10.5
min. thickness holes diameter

numero fori 5 interasse fori 150
number of holes bolt pattern

KYMC0	CC	MY	A	P
XCITING 500	500	05	DX	

▶ DF-40

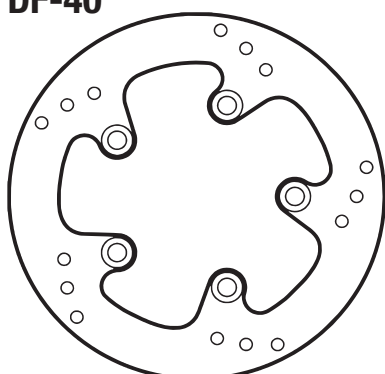

spessore minimo 4.5 diametro fori 10.5
min. thickness holes diameter

numero fori 5 interasse fori 110
number of holes bolt pattern

SUZUKI	CC	MY	A	P
AN BURGMAN	250	07	SX	
AN BURGMAN LEFT	400	07	SX	

DISCHI FRENO BRAKE DISKS

▶ DF-41

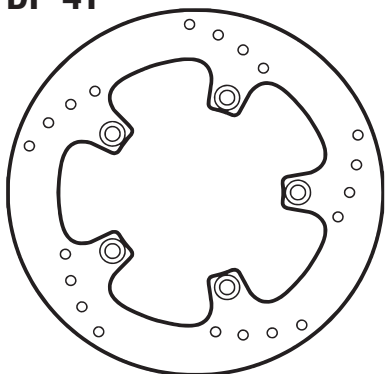

SUZUKI	CC	MY	A	P
AN BURGMAN	250	04 06	SX	
AN BURGMAN	250	07	DX	
AN BURGMAN	400	04 06	SX	
AN BURGMAN LEFT	400	07	DX	
AN BURGMAN RIGHT	400	07	DX	
AN BURGMAN EXECUTIVE	650	04 09	SX-DX	



spessore minimo
min. thickness 3.8 diametro fori
holes diameter 10.5

numero fori
number of holes 5 interasse fori
bolt pattern 142

▶ DF-42

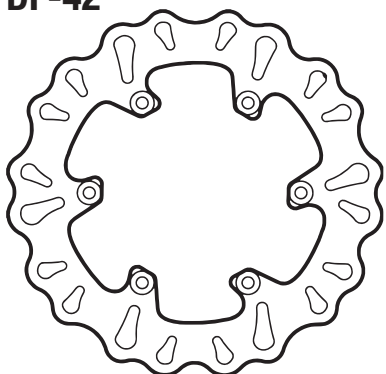

YAMAHA	CC	MY	A	P
T MAX BLACK MAX	500	06	SX	



spessore minimo
min. thickness 4.0 diametro fori
holes diameter 8.5

numero fori
number of holes 6 interasse fori
bolt pattern 150

Lamelle

Dimensionate in modo specifico per incrementare le prestazioni dei motori a due tempi, sono prodotte in diversi materiali ed in vari spessori per soddisfare tutte le esigenze.

La scelta dello spessore e del materiale della lamella permettono di variare la forma della curva di potenza per ottenere il rendimento migliore.

Reeds

Specifically designed to improve the performances of the 2-stroke engines, ADIGE® reeds are produced in 3 different materials and various thicknesses to satisfy all riders' requirements.

The choice of the thickness and material of the reeds allow the changing of the power curve to get the best engine efficiency.



ACCIAIO INOX:

per la sostituzione della lamella originale per chi non richiede un incremento di prestazioni; disponibili negli spessori: 0,15 – 0,20mm.

STAINLESS STEEL:

for the replacement of the original reeds, without increase of performances; available in the following thicknesses: 0.15 – 0.20mm.

FIBRA DI VETRO:

Le lamelle in fibra di vetro ADIGE® sono realizzate in uno speciale composto "fail-safe", che garantisce una maggiore durata rispetto all'originale. Le lamelle ADIGE® in fibra di vetro sono disponibili, in base alle applicazioni, negli spessori:
0,20 – 0,25 – 0,30 – 0,35
0,40 – 0,45 – 0,50 – 0,55
0,60 – 0,65 mm.

GLASS FIBER:

ADIGE® glass fiber reeds are produced in a special "fail-safe" material, to guarantee a better reed life compared with the stock ones. The ADIGE® glass fiber reeds are available, for the various applications, in the following thicknesses:
0.20 – 0.25 – 0.30 – 0.35
0.40 – 0.45 – 0.50 – 0.55
0.60 – 0.65mm.

FIBRA DI CARBONIO:

Le lamelle in fibra di carbonio ADIGE®, grazie alla alta flessibilità del materiale, consentono una maggiore apertura della lamella, garantendo un aumento delle prestazioni agli alti regimi migliorando il rendimento del motore. Le lamelle ADIGE® in fibra di carbonio sono disponibili negli spessori:
0,20 – 0,25 – 0,30 – 0,35
0,40 – 0,45 – 0,50 mm.

CARBON FIBER:

The ADIGE® carbon fiber reeds, thanks to the high quality and high flexibility of the material, allow a bigger opening of the reeds, increasing the engine performances at high RPM and improving the engine efficiency. The Carbon Fiber Reeds are available in the following thicknesses:
0.20 – 0.25 – 0.30 – 0.35
0.40 – 0.45 – 0.50mm.

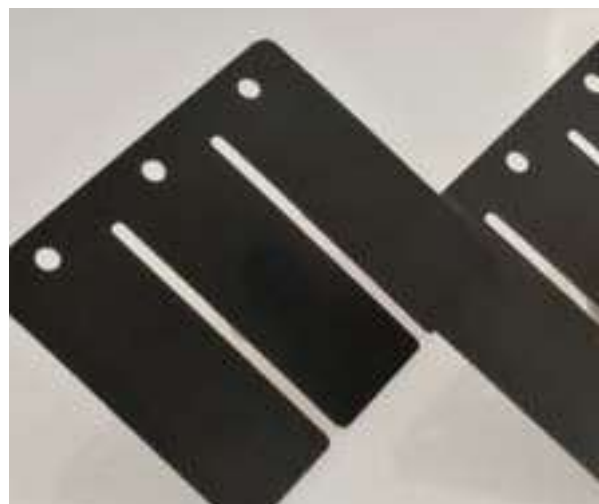

CODICE - PART

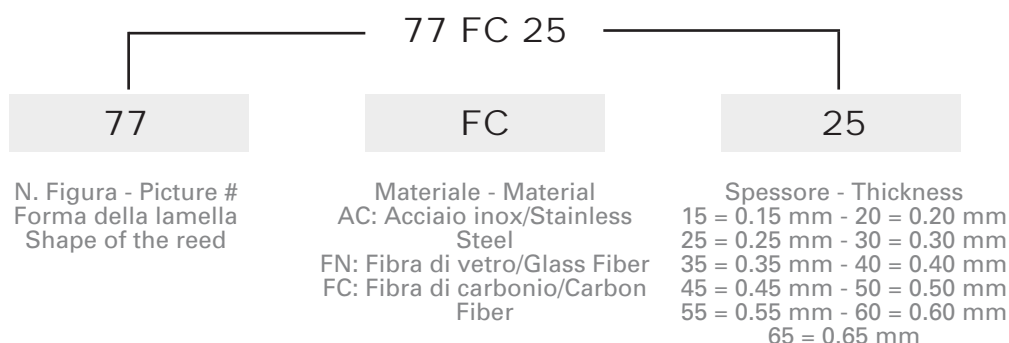

▶ 08

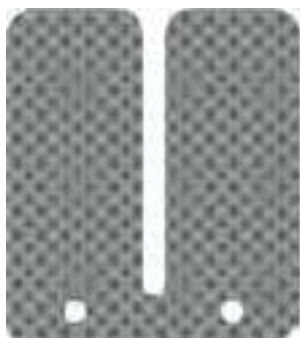

ACCIAIO	SPESSORE
08AC20	20
FIBRA DI VETRO	SPESSORE
08FN35	35
08FN40	40
08FN50	50



▶ 09

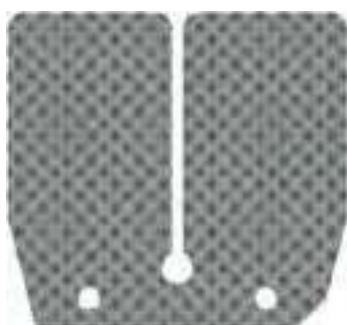

FIBRA DI VETRO	SPESSORE
09FN30	30
09FN40	40
09FN45	45
09FN50	50
09FN55	55
FIBRA DI CARBONIO	SPESSORE
09FC40	40



▶ 10

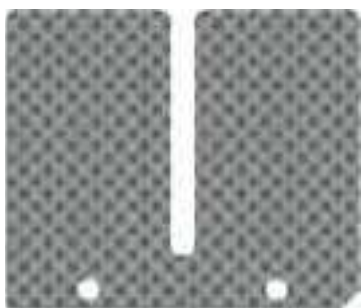

ACCIAIO	SPESSORE
10AC20	20
FIBRA DI VETRO	SPESSORE
10FN30	30
10FN50	50
FIBRA DI CARBONIO	SPESSORE
10FC40	40



▶ 12

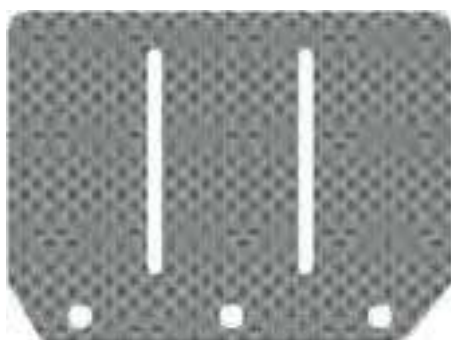

FIBRA DI VETRO	SPESSORE
12FN30	30
12FN35	35
12FN40	40
12FN45	45
FIBRA DI CARBONIO	SPESSORE
12FC30	30
12FC40	40



▶ 13

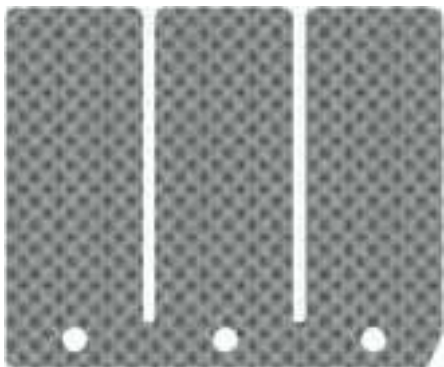

FIBRA DI VETRO	SPESSORE
13FN30	30
13FN35	35
13FN40	40
13FN50	50
13FN55	55
13FN60	60
FIBRA DI CARBONIO	SPESSORE
13FC30	30
13FC40	40



▶ 15

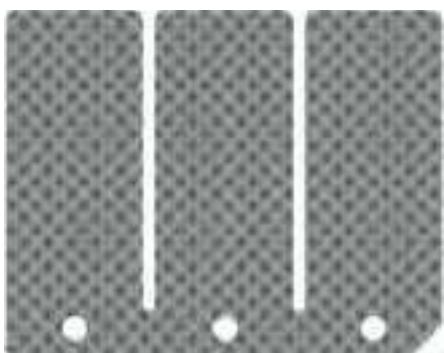

FIBRA DI VETRO	SPESSORE
15FN40	40
15FN50	50
15FN60	60
FIBRA DI CARBONIO	SPESSORE
15FC40	40



▶ 16

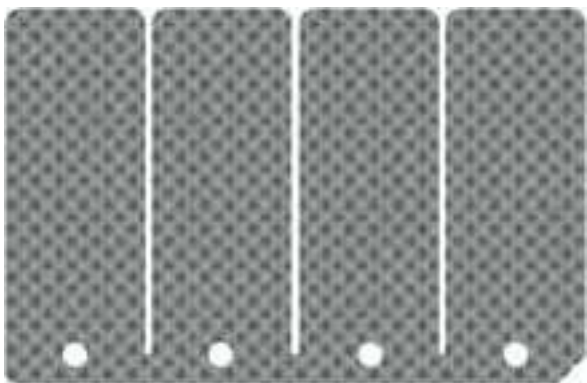

FIBRA DI VETRO	SPESSORE
16FN40	40
16FN45	45
16FN50	50
FIBRA DI CARBONIO	SPESSORE
16FC30	30
16FC40	40



▶ 19



FIBRA DI VETRO	SPESSORE
19FN25	25
19FN35	35
19FN40	40



▶ 23

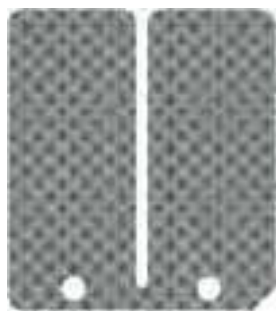

FIBRA DI VETRO	SPESSORE
23FN40	40

 35.5

 40

▶ 24/25

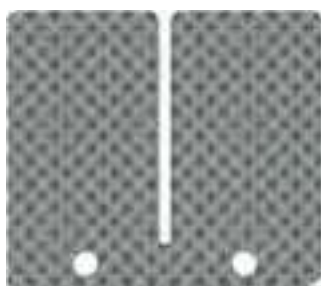
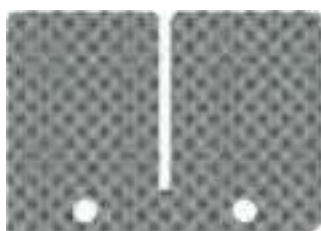

FIBRA DI VETRO	SPESSORE
24/25FN35	35
24/25FN40	40
FIBRA DI CARBONIO	SPESSORE
24/25FC30	30
24/25FC40	40

 42

 30

 42

 37

▶ 27



FIBRA DI VETRO	SPESSORE
27FN35	35

 17

 37

▶ 29

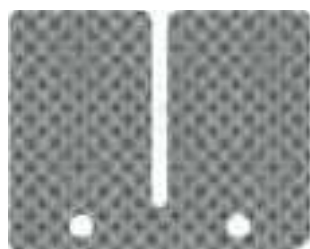

FIBRA DI VETRO	SPESSORE
29FN40	40
29FN45	45
29FN50	50
FIBRA DI CARBONIO	SPESSORE
29FC30	30
29FC40	40

 40

 32

▶ 32

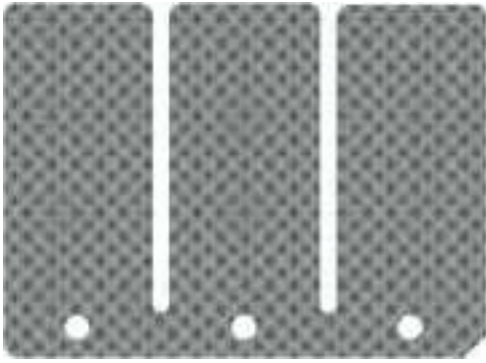

FIBRA DI VETRO	SPESSORE
32FN40	40
32FN50	50
FIBRA DI CARBONIO	SPESSORE
32FC30	30
32FC40	40



▶ 38



FIBRA DI CARBONIO	SPESSORE
38FC40	40



▶ 61

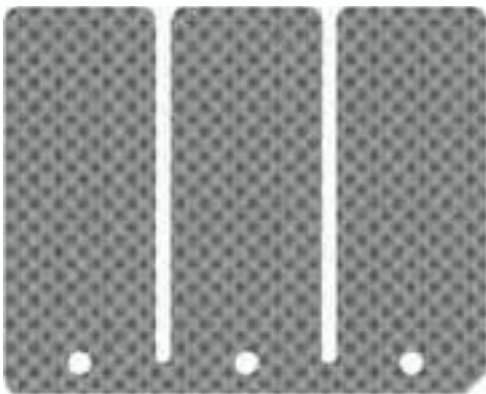

FIBRA DI VETRO	SPESSORE
61FN40	40
61FN45	45
61FN50	50
61FN60	60
FIBRA DI CARBONIO	SPESSORE
61FC40	40
61FC40/K	/K



▶ 75

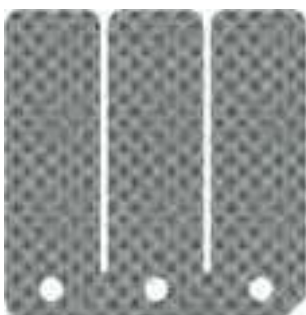

FIBRA DI CARBONIO	SPESSORE
75FC30	30



▶ 77



FIBRA DI VETRO		SPESSORE
77FN30		30
77FN40		40
FIBRA DI CARBONIO		SPESSORE
77FC25		25
77FC30		30

 38

 41.5

▶ 81



FIBRA DI VETRO		SPESSORE
81FN45		45
FIBRA DI CARBONIO		SPESSORE
81FC40		40

 64

 46

▶ 83

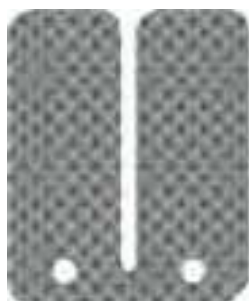

ACCIAIO		SPESSORE
83AC15		15
FIBRA DI VETRO		SPESSORE
83FN30		30
83FN35		35
83FN40		40
FIBRA DI CARBONIO		SPESSORE
83FC25		25
83FC30		30

 32

 39

▶ 90

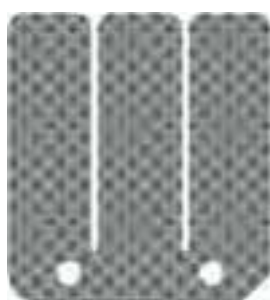

FIBRA DI CARBONIO		SPESSORE
90FC25		25
90FC30		30

 35

 38.5

▶ 91



FIBRA DI VETRO	SPESSORE
91FN50	50



▶ 93

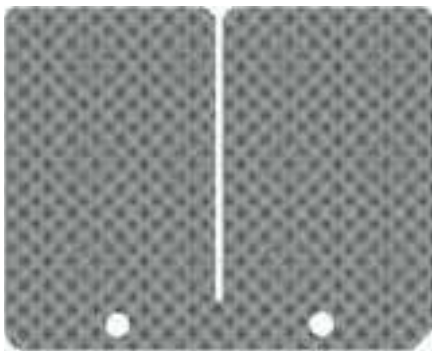

FIBRA DI VETRO	SPESSORE
93FN45	45

FIBRA DI CARBONIO	SPESSORE
93FC40	40



▶ 98

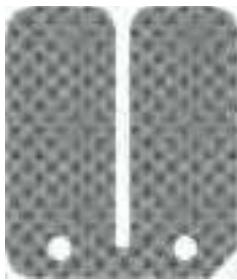

FIBRA DI VETRO	SPESSORE
98FN30	30

FIBRA DI CARBONIO	SPESSORE
98FC25	25
98FC30	30

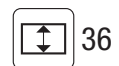

Valvole Lamellari

Le valvole lamellari hanno lo scopo di regolare ed ottimizzare il flusso della miscela in fase di aspirazione al fine di migliorare l'erogazione a tutti i regimi. Le valvole lamellari ADIGE®, scelte come primo equipaggiamento dalle più prestigiose Case motociclistiche, hanno il corpo valvola realizzato in materiale termoplastico o in alluminio trattato sul quale viene vulcanizzata una speciale miscela a base gomma (in FPM, NBR od ECO) inattaccabile da benzine ed ozono. Sono disponibili in versione standard o nelle versioni racing "Air Bag" e "Power-Reed Valve".

Reed Valves

Reed valves are used to regulate and optimize the gas flow during the intake phase, to improve the distribution at every speed and RPM. ADIGE® reed valves, used by the most important motorcycle companies, are produced using an aluminum or thermoplastic base covered by a vulcanized special rubber based compound (FPM, NBR or ECO), gas and ozone proof. ADIGE® reed valves are available for the most common 2-stroke engines in a standard version or in the following racing versions: "Air Bag" and "Power-Reed Valve".



AIR BAG:

La valvola lamellare ADIGE® "Air-Bag", specificatamente studiata per il motore Minarelli orizzontale, è dotata di un rivoluzionario sistema che ammortizza pneumaticamente l'apertura delle lamelle in aspirazione; si ottimizza così il sincronismo in funzione del rendimento e si migliora l'erogazione rendendola fluida e costante.

AIR BAG:

The ADIGE® "Air-Bag" Reed Valve, specifically designed for the Minarelli horizontal engine, is produced with a revolutionary system that pneumatically cushions the opening of the reeds during the intake phase; in this way the synchronism is optimized for the required performance, improving the gas flow.



VALVOLE POWER-REED:

La valvola lamellare regolabile ADIGE® "Power-Reed Valve", specificatamente studiata per l'applicazione sui motori 125cc a 2 tempi, consente, grazie alla particolare geometria della lamella, una completa regolazione da parte del pilota del flusso della miscela aria-benzina nel motore, variando la curva di potenza della moto ed adattandola alle caratteristiche del pilota e del tracciato.

Il suo utilizzo comporta i seguenti miglioramenti:

- Aumento della coppia motrice conseguente ad un miglior funzionamento del carter-pompa
- Spostamento del punto di potenza massima verso regimi più alti per un maggior allungo
- La scelta dello spessore, del materiale e della taratura della lamella permettono di variare la forma della curva di potenza per ottenere il rendimento migliore verso i medi o gli alti regimi.

POWER-REED VALVES:

The adjustable ADIGE® "Power-Reed Valve", specifically designed for the application on the most powerful 2-stroke engines, allow the rider, thanks to the special structure of the reeds, to control completely the gas-air flow into the engine, changing the power curve of the bike and adapting it to the rider's and track's peculiarities. The use of the ADIGE® "Power-Reed Valve" creates the following improvements:

- Increase of torque, due to the better functioning of the crankshaft-pump
- Shift of the maximum power point to higher RPM, getting a better utilization of the engine
- The choice of the thickness and material of the reeds and the set-up of the reed itself allow the changing of the power curve to get the best engine efficiency at medium or high RPMs.



VALVOLE LAMELLARI STANDARD REED VALVES

► BR-51



APRILIA	CC	MY
AF 1	125	85
AF 1 FUTURA	125	90
AF 1 REPLICA	125	89
AF 1 SINTESI	125	89
CLASSIC	125	96 01
ETX	125	85
ETX	125	86
ETX PV	125	85
EUROPA	125	91
MX	125	04
PEGASO	125	89
PEGASO	125	91
PEGASO KAT	125	93
RC	125	89
RED ROSE	125	89
RED ROSE AE	125	91
RS	125	93 97
RS	125	98 05
RX	125	86 89

RX	125	90
RX	125	91
RX	125	85
RX	125	92 93
RX	125	94 99
SPORT PRO	125	93
TUAREG RALLY	125	85 88
TUAREG RALLY	125	89 90
TUAREG RALLY	125	91
TUAREG WIND	125	89
TUONO	125	04
TX M	125	85

► FB-128



MINARELLI	CC	MY
DT RAFFR. ACQUA	125	88
DT RAFFR. ACQUA YPVS	125	88
YAMAHA	CC	MY
TDR	125	89 92
TDR R	125	93 03

VALVOLE LAMELLARI STANDARD REED VALVES

► FB-146



APRILIA	CC	MY
AREA 51	50	98 99
AREA 51 SBK	50	00 02
GULLIVER	50	95 00
GULLIVER L.C.	50	96 00
RALLY	50	94 00
RALLY L.C.	50	97
SCARABEO	50	94 97
SCARABEO	50	98 02
SCARABEO DE LUXE	50	98 01
SONIC-SONIC G.P.	50	98
SR	50	93 00
SR EUROPA	50	94
SR RACING KAT.	50	00
SR REPLICA	50	92
SR REPLICA	50	93
SR STEALTH L.C.	50	97
SR URBAN	50	94
SR WWW	50	97
SCARABEO	100	00 02
SCARABEO	100	03 07
BENELLI	CC	MY
491 GT	50	98
491 NAKED	50	98
491 SPORT	50	98
491 SUPERBIKE-491 R	50	98
K 2	50	98
K 2 LIQUIDO	50	98
K 2 NAMUR	50	98
PEPE	50	99
K 2	100	99
BETA	CC	MY
ARK	50	96
ARK L.C.	50	97
CHRONO	50	94
EIKON	50	99 06

QUADRA	50	97 01
TEMPO	50	98 02
TEMPO 13	50	94 97
ITALJET	CC	MY
DRAGSTER	50	98
MALAGUTI	CC	MY
CENTRO SL	50	94
CIAK	50	99
F 10	50	92
F 10	50	96
F 12 PHANTHOM	50	94
F 12 PHANTHOM	50	98
F 12 PHANTHOM	50	99
F 15 FIREFOX	50	97
F 15 FIREFOX L.C.	50	99
YESTERDAY	50	98
F 12 PHANTHOM	100	00
MBK	CC	MY
FLIPPER	50	99
NEW SORRISO	50	99
NITRO	50	97
OVETTO	50	98
STUNT	50	00
MOTRON	CC	MY
SPIKE	50	98
SYNCRO	50	98
YAMAHA	CC	MY
AEROX	50	97
C3	50	07
NEO'S	50	97
SLIDER	50	00
WHY	50	98
ZUMA	50	05 08
AEROX	100	00
BW'S	100	00
NEO'S	100	00

► H0-107



HONDA	CC	MY
CR RC	125	82
CR RD-RE-RF-RG	125	83 86
CR RH-J-K-L-M-N-P-R-S-T-X	125	94 00
CRM R	125	90 99
NSR-FM-FN	125	88 89
NSR-FM-FN	125	90
NSR-FM-FN	125	91 03
NSR-RK-RL-RM-RN-RP-RR	125	89
XL V VARADERO	125	01 05
XL-K2- K4-SZ-SA	125	78 80
XL-SB-SC	125	81 82

VALVOLE LAMELLARI STANDARD REED VALVES

▶ KT-59

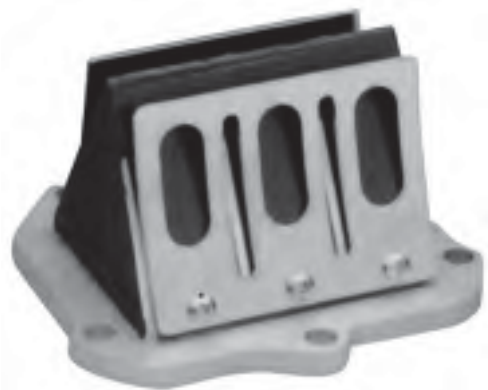

KTM	CC	MY
GS	125	89 90
GS	125	91 92
GS	125	93
GS	125	94 97
MX	125	86 87
MX	125	88
MX	125	89 91
MX	125	92
EXC-EGS- SX	250	93 95
EXC-EGS-SX	250	96 02
GS	250	89 90
GS	250	91 92
GS	250	93
GS	250	94
MX	250	88
MX	250	89
MX	250	90 02
SX-EGS-EXC	250	93 95
SX-EGS-EXC	250	96 02

▶ MA-143



CAGIVA	CC	MY
WMX	250	88
WMX GP	250	82
WMX	500	86
WMX	500	87

▶ MA-189



CAGIVA	CC	MY
K 7	125	91
MITO	125	90 92
MITO EDDY	125	93
MITO SPORT PRODUCTION	125	91
RAPTOR	125	03
SUPER CITY	125	93 00
W 8 PRO ACTION	125	91

VALVOLE LAMELLARI STANDARD REED VALVES

▶ MF-102



BETA	CC	MY
TR 34	125	88
TR 34 R CAMPIONATO	125	89
TR 35	125	91
ZERO	125	92
ALP	240	96
SYNT	260	92 93
SYNT	260	94
TR 34 R CAMPIONATO	260	88
TR 34 R SUPER TRIAL	260	89
TR 35 REVERSE	260	90
ZERO	260	89 92
ZERO	260	98
ZERO GARA	260	93

▶ MF-84



APRILIA	CC	MY
ET	50	85
TUAREG	50	85
TUAREG	50	86
MALAGUTI	CC	MY
GRIZZLY	50	87

▶ YA-38



HONDA	CC	MY
MB SA-SB	50	80 82
MBX SD-SF-SH	50	83 87
MT SA-SE-SG-SJ-SL	50	80 93
MTX SD	50	83 87
YAMAHA	CC	MY
RD	80	82 85
RD LC	80	82 84

► PWR-1



RICAMBI

91FN50

Lamelle

CAGIVA	CC	MY
ALETTA ORO S 2	125	86
BLUES	125	88
BLUES	125	93
CRUISER	125	87 88
E 2	125	86
ELECTRA	125	88
ELEFANT	125	81 84
ELEFANT	125	85 87
ELEFANT 3	125	88
FRECCIA	125	87
FRECCIA C 10	125	88
FRECCIA C 10 ANNIVERSARY	125	89
FRECCIA C 12 R	125	89
FRECCIA C 9	125	88
K 7	125	91
MITO	125	90 92
MITO EDDY	125	93
MITO SPORT PRODUCTION	125	91
N 90	125	91
PLANET	125	98 03
RAPTOR	125	03
ROADSTER	125	98 99
SST	125	81
SUPER CITY	125	93 00
TAMANACO	125	89
W 8	125	92 98
W 8 PRO ACTION	125	91
WMX	125	85
WMX	125	87
WMX	125	88
WMX	125	90
WSTX ALETTA ROSSA	125	83
ELEFANT	200	88
ELEFANT	200	89
GILERA	CC	MY
APACHE	125	92
CCM APTS	125	87
CRONO AE	125	91
CX-AE	125	91

ER	125	87
FAST BIKE	125	87
FREESTYLE	125	92
GFR	125	93
KZ	125	86
KZ ENDURANCE	125	88
MX 1	125	88
MXR	125	89
R 1	125	88
RC	125	90
RC RALLY	125	88
RC TOP RALLY	125	90
RRT NEBRASKA	125	87
RTX	125	86
RV	125	84
RV ES	125	87
RVE A-E	125	87
RX ARIZONA	125	83
SATURNO PIUMA	125	90
SP 01	125	89
SP 02	125	90
TX 1	125	88
X 1	125	89
XR 1	125	88
XR 2	125	89
HONDA	CC	MY
CR RC	125	82
CR RD-RE-RF-RG	125	83 86
CR RH-J-K-L-M-N-P-R-S-T-X	125	94 00
CRM R	125	90 99
NSR-FM-FN	125	88 89
NSR-FM-FN	125	90
NSR-FM-FN	125	91 03
NSR-RK-RL-RM-RN-RP-RR	125	89
XL V VARADERO	125	01 05
XL-K2- K4-SZ-SA	125	78 80
XL-SB-SC	125	81 82
LAVERDA	CC	MY
NAVARRO	125	90
TOLEDO	125	90

VALVOLE POWER REED POWER REED VALVES

► PWR-2



RICAMBI

91FN50

Lamelle

APRILIA	CC	MY
AF 1	125	85
AF 1 FUTURA	125	90
AF 1 REPLICIA	125	89
AF 1 SINTESI	125	89
CLASSIC	125	96 01
ETX	125	85
ETX	125	86
ETX PV	125	85
EUROPA	125	91
MX	125	04
PEGASO	125	89
PEGASO	125	91
PEGASO KAT	125	93
RC	125	89
RED ROSE	125	89
RED ROSE AE	125	91
RS	125	93 97
RS	125	98 05
RX	125	86 89
RX	125	90
RX	125	91
RX	125	85
RX	125	92 93
RX	125	94 99
SPORT PRO	125	93

TUAREG RALLY	CC	MY
TUAREG RALLY	125	85 88
TUAREG RALLY	125	89 90
TUAREG RALLY	125	91
TUAREG WIND	125	89
TUONO	125	04
TX M	125	85
KTM	CC	MY
GS	125	89 90
GS	125	91 92
GS	125	93
GS	125	94 97
MX	125	86 87
MX	125	88
MX	125	89 91
MX	125	92
EXC-EGS- SX	250	93 95
EXC-EGS-SX	250	96 02
GS	250	89 90
GS	250	91 92
GS	250	93
GS	250	94
MX	250	88
MX	250	89
MX	250	90 02
SX-EGS-EXC	250	93 95
SX-EGS-EXC	250	96 02



Collettori d'aspirazione

La speciale tecnologia sviluppata da ADIGE® per lo stampaggio della gomma sul metallo ha portato ADIGE® a proporre sul mercato soluzioni fortemente innovative per l'applicazione a prodotti come i collettori d'aspirazione.

I collettori ADIGE®, sviluppati in collaborazione con le più prestigiose Case motociclistiche internazionali e studiati in relazione alle esigenze funzionali del motore ed agli ingombri di telaio e carrozzeria, presentano una struttura composita in quanto vengono prodotti partendo da un inserto in lega d'alluminio sul quale viene vulcanizzata una speciale miscela a base gomma (in FPM, NBR od ECO) inattaccabile da benzine ed ozono.

In questo modo vengono garantite sia una notevole rigidità della base di fissaggio al carter sia una buona elasticità del corpo del collettore.

Intake Manifolds

The special technology developed by ADIGE® for the vulcanization of the rubber on to aluminum enabled ADIGE® to introduce innovative solutions for products like intake manifolds to the market.

The ADIGE® intake manifolds are developed in cooperation with the most important motorcycle manufacturers and designed to meet the functional engine requirements and the overall frame dimensions, consist of an aluminum flange integrated with a special rubber covering (in FPM, NBR or ECO) making them gas and ozone proof.

In this way, both an outstanding rigidity of the crankshaft coupling and good flexibility of the intake manifold body are guaranteed.



▶ BR-53



APRILIA	CC	MY
RED ROSE	125	89
RED ROSE AE	125	91

▶ BR-54



APRILIA	CC	MY
ETX	125	85
ETX	125	86
ETX PV	125	85
PEGASO	125	89
PEGASO	125	91
PEGASO KAT	125	93
RX	125	86 89
RX	125	90
RX	125	91
RX	125	85
RX	125	92 93

RX	125	94 99
TUAREG RALLY	125	85 88
TUAREG RALLY	125	89 90
TUAREG RALLY	125	91
TUAREG WIND	125	89
TX M	125	85

▶ BR-60



APRILIA	CC	MY
AF 1	125	85
AF 1 FUTURA	125	90
AF 1 REPLICA	125	89
AF 1 SINTESI	125	89
CLASSIC	125	96 01
MX	125	04
RS	125	93 97
RS	125	98 05
TUONO	125	04

COLLETTORI D'ASPIRAZIONE INTAKE MANIFOLDS

► BR-61



APRILIA	CC	MY
EUROPA	125	91
SPORT PRO	125	93

► FB-134



APRILIA	CC	MY
AMICO	50	90 91
AMICO SPORT LX	50	92
CAGIVA	CC	MY
CITY	50	92 94
PASSING	50	95
FANTIC	CC	MY
BIG WHEELS	50	91
BIP RACING	50	94
GRINTA	50	97
PONY SR	50	92
QUEENIE	50	95
ITALJET	CC	MY
BAZOOKA	50	92 97
CRUISE	50	95
PISTA	50	92
YANKEE	50	94
MBK	CC	MY
BOOSTER N.G.	50	95 98
BOOSTER N.G.	50	99
BOOSTER R	50	93 95
BOOSTER SPIRIT	50	95 98
BOOSTER SPIRIT	50	99
BOOSTER TRACK	50	96

FIZZ	50	94
FORTE	50	94
SORRISO	50	92
TARGET	50	92 94
MOTRON	CC	MY
STING	50	95
THUNDER SC	50	95
YAMAHA	CC	MY
AXIS	50	94
BREEZE	50	95
BW'S	50	91 92
BW'S BUMP	50	96
BW'S N.G.	50	96
BW'S R	50	95
BW'S SPY	50	96
CRZ	50	92
CW T ZUMA	50	89 90
CW ZUMA	50	02 05
CW ZUMA II	50	00 01
JOG	50	88 91
JOG	50	92
JOG R	50	94
SPY	50	95

► FB-135



APRILIA	CC	MY
AREA 51	50	98 99
AREA 51 SBK	50	00 02
GULLIVER	50	95 00
GULLIVER L.C.	50	96 00
RALLY	50	94 00
RALLY L.C.	50	97
SCARABEO	50	94 97
SCARABEO	50	98 02
SCARABEO DE LUXE	50	98 01
SONIC-SONIC G.P.	50	98
SR	50	93 00
SR EUROPA	50	94
SR RACING KAT.	50	00
SR REPLICA	50	92
SR REPLICA	50	93
SR STEALTH L.C.	50	97
SR URBAN	50	94
SR WWW	50	97
SCARABEO	100	00 02
SCARABEO	100	03 07
BENELLI	CC	MY
491 GT	50	98
491 NAKED	50	98
491 SPORT	50	98
491 SUPERBIKE-491 R	50	98
K 2	50	98
K 2 LIQUIDO	50	98
K 2 NAMUR	50	98
PEPE	50	99
K 2	100	99
BETA	CC	MY
ARK	50	96
ARK L.C.	50	97
CHRONO	50	94
EIKON	50	99 06
QUADRA	50	97 01

TEMPO	50	98 02
TEMPO 13	50	94 97
ITALJET	CC	MY
DRAGSTER	50	98
MALAGUTI	CC	MY
CENTRO SL	50	94
CIAK	50	99
CROSSER	50	99
F 10	50	92
F 10	50	96
F 12 PHANTHOM	50	94
F 12 PHANTHOM	50	98
F 12 PHANTHOM	50	99
F 15 FIREFOX	50	97
F 15 FIREFOX L.C.	50	99
YESTERDAY	50	98
F 12 PHANTHOM	100	00
MBK	CC	MY
FLIPPER	50	99
NEW SORRISO	50	99
NITRO	50	97
OVETTO	50	98
STUNT	50	00
MOTRON	CC	MY
SPIKE	50	98
SYNCRO	50	98
YAMAHA	CC	MY
AEROX	50	97
C3	50	07
NEO'S	50	97
SLIDER	50	00
WHY	50	98
ZUMA	50	05 08
AEROX	100	00
BW'S	100	00
NEO'S	100	00

► FM-57



FANTIC	CC	MY
TRIAL	305	89
TRIAL	307	90
K ROO	309	91

► MA-205



CAGIVA	CC	MY
PRIMA	75	92

▶ VE-371



GILERA	CC	MY
EASY MOVING	50	96
ICE	50	01
NRG	50	93
NRG	50	96
NRG-MC2	50	99 00
NRG-MC3	50	01
NTT	50	94
NTT	50	96
RUNNER	50	97
RUNNER DD	50	97
RUNNER SP	50	01 04
RUNNER SP	50	05
STALKER DD	50	99
STALKER DT	50	99
TYPHOON	50	96 00
TYPHOON X	50	01
HONDA	CC	MY
BALI	50	93
DAX ST	50	93
DIO SCOOTER	50	91
DIO ZX	50	94
GP DIO	50	92
SFX	50	95
SH SCOOPY	50	96
SKY	50	97
X 8 R	50	98
ZX SCOOTER	50	94
BALI	100	99
KYMCO	CC	MY
DJX	50	94
DJY	50	94
FEVER ZX	50	97
HEROISM	50	95
K 12	50	95
K B	50	95
PEOPLE	50	99 02
SCOUT	50	99
SNIPER DD	50	94
SUPER-9 L.C.	50	00
TOP BOY	50	97
ZX	50	05

TOP BOY	100	98
PGO	CC	MY
BIG MAX	50	95
MEGA FIFTY	50	99
PMS	50	99
PMX	50	99
T REX	50	99
PIAGGIO	CC	MY
FLY (E.U.)	50	05
FLY (U.S.)	50	05
FREE	50	96 00
FREE	50	01
FREE	50	02
LIBERTY	50	97 07
LIBERTY 4T	50	00 07
NRG EXTREME	50	01
NRG EXTREME ACQUA	50	96 00
NRG EXTREME ARIA	50	96 00
NRG=MC2	50	99
NTT	50	95
QUARTZ	50	91 95
SFERA	50	90 95
SFERA	50	96
SFERA ET2	50	97
SFERA RST	50	95
TYPHOON	50	94 97
TYPHOON	50	07 08
TYPHOON	50	01 03
TYPHOON X	50	98 00
TYPHOON SE	50	06
ZIP	50	93 95
ZIP 4T KAT.	50	00
ZIP FAST RIDER	50	93
ZIP FAST RIDER	50	00
ZIP II	50	01
ZIP RST	50	96 99
ZIP RST	50	00
ZIP SP L.C.	50	96 99
ZIP SP L.C.	50	00
TYPHOON	80	96
VESPA	CC	MY
VESPA ET2	50	99

▶ VE-383



APRILIA	CC	MY
SR	125	99
SR	150	00
GILERA	CC	MY
RUNNER FXR (G)	180	00
RUNNER FXR (H)	180	00
RUNNER FXR SP (G)	180	99
RUNNER FXR SP (H)	180	99
PIAGGIO	CC	MY
HEXAGON GTX (G)	125	00
HEXAGON GTX (H)	125	00
HEXAGON LX (G)	125	98 99
HEXAGON LX (H)	125	98 99

SKIPPER	125	93
SKIPPER LX	125	96 97
SKIPPER LX 2T (G)	125	98 99
SKIPPER LX 2T (H)	125	98 99
HEXAGON	150	94 99
SKIPPER LXT 2T	150	98
HEXAGON LXT (G)	180	98 99
HEXAGON LXT (H)	180	98 99



Fermacopertoni

I fermacopertoni ADIGE®, studiati in collaborazione con i Reparti Corse delle più prestigiose Case motociclistiche, sono realizzati con la tecnologia sviluppata da ADIGE® per lo stampaggio della gomma sul metallo.

Il totale rivestimento dell'inserto di alluminio con una speciale miscela a base gomma evita il danneggiamento e lo slittamento del pneumatico sul cerchio. Costruiti con materiali di prima qualità i fermacopertoni ADIGE® rappresentano la giusta scelta per ottenere i migliori risultati.

Dimensioni disponibili:

Ruota Anteriore:

1,60" – 1,85"

Ruota Posteriore:

2,15" – 2,50"

Tire Locks

ADIGE® has used their many years of experience in the field of off-road racing to develop a line of tire locks produced with the special technology developed by ADIGE® for the vulcanization of the rubber on the aluminum.

The ADIGE® tire locks are completely covered with a special rubber that prevent tire damage and eliminate the problem of tires slipping on the rim.

The locks are so effective that they have become the primary choice of many of the world's leading motorcycle manufactures.

Available dimensions:

Front tire:

1.60" – 1.85"

Rear tire:

2.15" – 2.50"

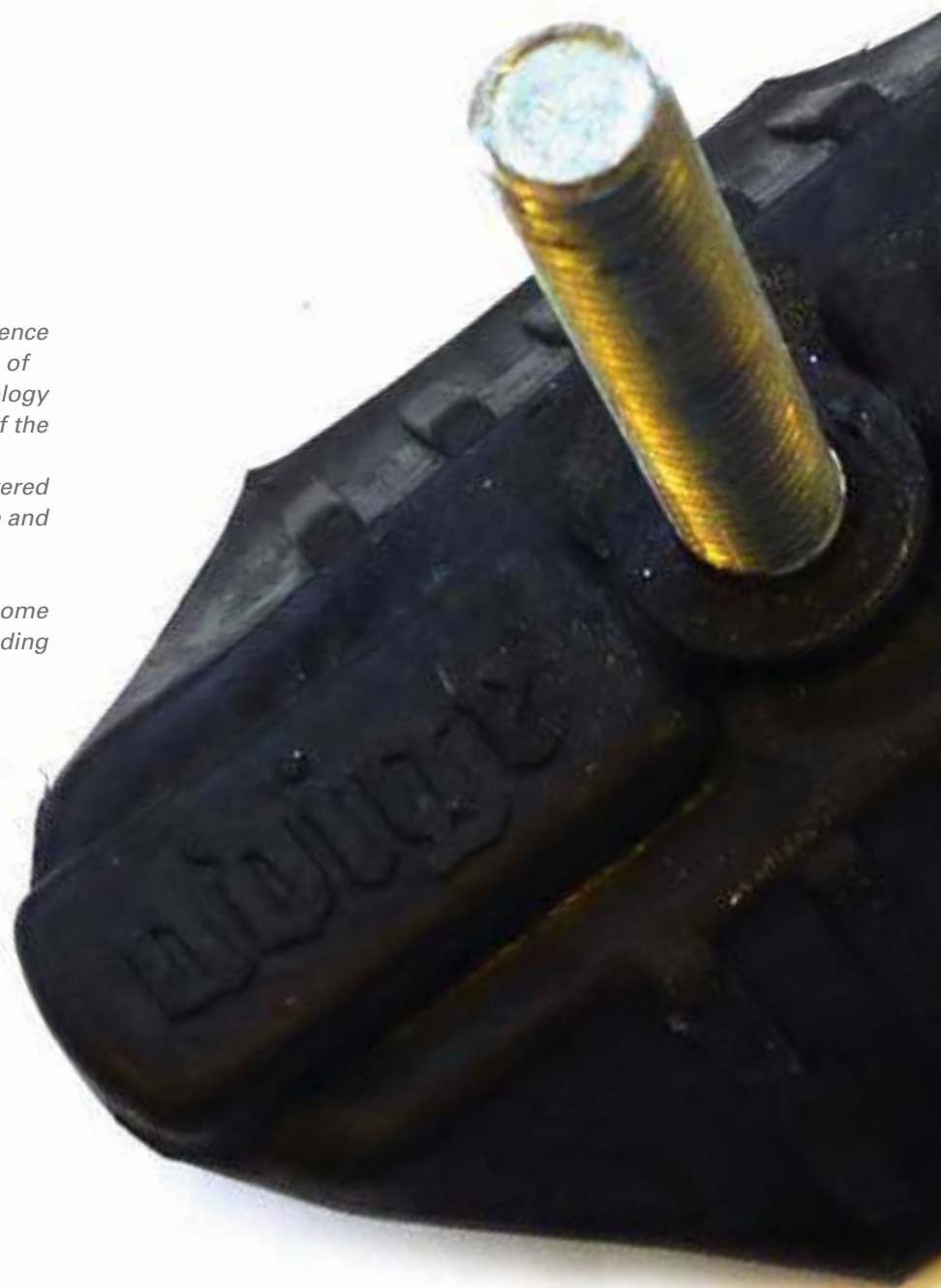

▶ MA-139



APRILIA	CC	MY	A	P
RX	50	90 91	•	
RX	50	92 97	•	
RX	50	98	•	
RX C-CD	50	93	•	
RX RACING	50	04 06	•	
TUAREG	50	87 90	•	
TUAREG	50	91	•	
TUAREG RALLY	50	90	•	
TUAREG WIND	50	90	•	
CLASSIC	80	93	•	
PEGASO	125	89	•	
PEGASO	125	91	•	
PEGASO KAT	125	93	•	
RX	125	86 89	•	
RX	125	90	•	
RX	125	91	•	
RX	125	85	•	
RX	125	92 93	•	
RX	125	94 99	•	
TX M	125	85	•	
CAGIVA	CC	MY	A	P
W 8	125	92 98	•	
W 8 PRO ACTION	125	91	•	
WMX	125	85	•	
WMX	125	87	•	
WMX	125	88	•	
WMX	125	90	•	
ELEFANT	200	88	•	
ELEFANT	200	89	•	
WMX	250	88	•	
WMX	250	91	•	
WMX GP	250	82	•	
HONDA	CC	MY	A	P
CR RC	125	82	•	
CR RD-RE-RF-RG	125	83 86	•	

CR RH-J-K-L-M-N-P-R-S-T-X	125	94 00	•	
CRM R	125	90 99	•	
CR RD-RK	250	83 86	•	
CR RD-RK	250	87 89	•	
CR RL-RM-RN-RP	250	90 93	•	
CR RR-RX	250	94 01	•	
CR RR-RX	250	02	•	
CR RE-RG-RH-RJ-RK	500	84 86	•	
CR RL-RM-RN-RP-RR-RS-RT	500	94 00	•	
HUSQVARNA	CC	MY	A	P
CR	125	92 95	•	
CR	125	96 04	•	
CR	125	05	•	
WR	125	95 05	•	
WR	125	06	•	
WRE	125	94 00	•	
CR	250	92 95	•	
WR	250	84 90	•	
WR	250	91 92	•	
WR	250	06	•	
WR	260	91	•	
TE	350	95 97	•	
CR	360	92 93	•	
CR	360	94	•	
WR	360	92 93	•	
WR	360	94	•	
TE	410	94 05	•	
TE	410	06	•	
TE E	410	01	•	
TE LC	510	89	•	
LT	610	00	•	
SM R	610	00 05	•	
SM S	610	00 05	•	
SM S	610	06	•	
TC	610	95	•	
TE	610	92 94	•	
TE	610	95 99	•	
TE E	610	00 03	•	
KAWASAKI	CC	MY	A	P
KX D1	125	85	•	
KX E2/F1	125	87 88	•	
KX G1/H1-H2/J1-J2	125	89 94	•	
KX K1-K5/L1-L4	125	95 03	•	
KX M1-M2-M3	125	04	•	
KX D1	250	85	•	
KX E1-F1	250	87 88	•	
KX K1	250	94	•	
KX K2-K5/L1-L5	250	95 02	•	
KX C1/D1	500	87 88	•	
KX E1-E5	500	89 93	•	
KX E6-E7	500	94 95	•	
KX E8-E16	500	96 04	•	
KTM	CC	MY	A	P
GS	125	89 90	•	
GS	125	91 92	•	

GS	125	93	•	
GS	125	94 97	•	
MX	125	86 87	•	
MX	125	88	•	
MX	125	89 91	•	
MX	125	92	•	
EXC-EGS- SX	250	93 95	•	
EXC-EGS-SX	250	96 02	•	
GS	250	89 90	•	
GS	250	91 92	•	
GS	250	93	•	
GS	250	94	•	
MX	250	88	•	
MX	250	89	•	
MX	250	90 02	•	
SX-EGS-EXC	250	93 95	•	
SX-EGS-EXC	250	96 02	•	
MX	350	87 88	•	
MX	350	89 91	•	
MX	350	92	•	
WMX	350	88	•	
GS	500	89	•	
K 4	500	83	•	
MX	500	86	•	
MX	500	87	•	
MX	500	88	•	
MX	500	89 91	•	
MX	500	92	•	
SX	500	93	•	
WMX	500	88	•	
XC-MC	500	83	•	
SUZUKI	CC	MY	A	P
RM E	125	84	•	
RM F	125	85	•	
RM G	125	86	•	
RM H	125	87	•	
RM J	125	88	•	
RM K/L/M	125	89 91	•	
RM N/P/R/S	125	92 95	•	
RM G	250	86	•	
RM H	250	87	•	
RM J/K/L/M	250	88	•	
RM J/K/L/M	250	89 91	•	
RM N/P	250	92 93	•	
RM R/S	250	94 95	•	
RM T/V/W/X/Y/K1-K2	250	96 02	•	
RMX K/L/M	250	89 91	•	
RMX N/P	250	92 93	•	
RMX R/S	250	94 95	•	
RMX ST/SV/SW/SX	250	96 99	•	
RMX T/V/W	250	96 98	•	
YAMAHA	CC	MY	A	P
WR ZB/ZD/ZE	250	91 93	•	
WR ZF/ZG/ZH/ZJ	250	94 97	•	

▶ MA-140



HONDA	CC	MY	A	P
CR RC	125	82	•	•
CR RD-RE-RF-RG	125	83 86	•	•
CR RH-J-K-L-M-N-P-R-S-T-X	125	94 00	•	•
CRM R	125	90 99	•	•
KAWASAKI	CC	MY	A	P
KX D1	125	85	•	•
KX E2/F1	125	87 88	•	•
KX G1/H1-H2/J1-J2	125	89 94	•	•
KX K1-K5/L1-L4	125	95 03	•	•
KX M1-M2-M3	125	04	•	•
KTM	CC	MY	A	P
ENDURO	300	92	•	•
ENDURO	300	93	•	•

SUZUKI	CC	MY	A	P
RM E	125	84	•	•
RM F	125	85	•	•
RM G	125	86	•	•
RM H	125	87	•	•
RM J	125	88	•	•
RM K/L/M	125	89 91	•	•
RM N/P/R/S	125	92 95	•	•
YAMAHA	CC	MY	A	P
YZ K/L	125	83 84	•	•

▶ MA-152



APRILIA	CC	MY	A	P
TUAREG	50	87 90	•	•
TUAREG	50	91	•	•
TUAREG RALLY	50	90	•	•
TUAREG WIND	50	90	•	•
PEGASO	125	89	•	•
PEGASO	125	91	•	•
PEGASO KAT	125	93	•	•
RX	125	86 89	•	•
RX	125	90	•	•
RX	125	91	•	•
RX	125	85	•	•
RX	125	92 93	•	•
RX	125	94 99	•	•
TX M	125	85	•	•
CAGIVA	CC	MY	A	P
W 8	125	92 98	•	•
W 8 PRO ACTION	125	91	•	•
WMX	125	85	•	•
WMX	125	87	•	•

WMX	125	88	•	•
WMX	125	90	•	•
ELEFANT	200	88	•	•
ELEFANT	200	89	•	•
WMX	250	88	•	•
WMX	250	91	•	•
WMX GP	250	82	•	•
HONDA	CC	MY	A	P
CR RD-RK	250	83 86	•	•
CR RD-RK	250	87 89	•	•
CR RL-RM-RN-RP	250	90 93	•	•
CR RR-RX	250	94 01	•	•
CR RR-RX	250	02	•	•
CR RE-RG-RH-RJ-RK	500	84 86	•	•
CR RL-RM-RN-RP-RR-RS-RT	500	94 00	•	•
HUSQVARNA	CC	MY	A	P
CR	125	92 95	•	•
CR	125	96 04	•	•
CR	125	05	•	•
WR	125	95 05	•	•
WR	125	06	•	•
WRE	125	94 00	•	•
CR	250	92 95	•	•
WR	250	84 90	•	•
WR	250	91 92	•	•
WR	250	93 05	•	•
WR	250	06	•	•
WR	260	91	•	•
TE	350	95 97	•	•
CR	360	92 93	•	•
CR	360	94	•	•
WR	360	92 93	•	•
WR	360	94	•	•
TE	410	94 05	•	•
TE	410	06	•	•
TE E	410	01	•	•
TE LC	510	89	•	•
LT	610	00	•	•
SM R	610	00 05	•	•
SM S	610	00 05	•	•

SM S	610	06	•	•
TC	610	95	•	•
TE	610	92 94	•	•
TE	610	95 99	•	•
TE E	610	00 03	•	•
KAWASAKI	CC	MY	A	P
KX G1/H1-H2/J1-J2	125	89 94	•	•
KX D1	250	85	•	•
KX E1-F1	250	87 88	•	•
KX K1	250	94	•	•
KX K2-K5/L1-L5	250	95 02	•	•
KX C1/D1	500	87 88	•	•
KX E1-E5	500	89 93	•	•
KX E6-E7	500	94 95	•	•
KX E8-E16	500	96 04	•	•
KTM	CC	MY	A	P
GS	125	89 90	•	•
GS	125	91 92	•	•
GS	125	93	•	•
GS	125	94 97	•	•
MX	125	86 87	•	•
MX	125	88	•	•
MX	125	89 91	•	•
MX	125	92	•	•
EXC-EGS-SX	250	93 95	•	•
EXC-EGS-SX	250	96 02	•	•
GS	250	89 90	•	•
GS	250	91 92	•	•
GS	250	93	•	•
GS	250	94	•	•
MX	250	88	•	•
MX	250	89	•	•
MX	250	90 02	•	•
SX-EGS-EXC	250	93 95	•	•
SX-EGS-EXC	250	96 02	•	•
YAMAHA	CC	MY	A	P
WR ZB/ZD/ZE	250	91 93	•	•
WR ZF/ZG/ZH/ZJ	250	94 97	•	•

▶ MA-153



KTM	CC	MY	A	P
ENDURO	300	92		•
ENDURO	300	93		•
MX	350	87	88	•
MX	350	89	91	•
MX	350	92		•
WMX	350	88		•
GS	500	89		•
K 4	500	83		•
MX	500	86		•
MX	500	87		•
MX	500	88		•
MX	500	89	91	•
MX	500	92		•
SX	500	93		•
WMX	500	88		•

XC-MC	500	83		•
SUZUKI	CC	MY	A	P
RM G	250	86		•
RM H	250	87		•
RM J/K/L/M	250	88		•
RM J/K/L/M	250	89	91	•
RM N/P	250	92	93	•
RM R/S	250	94	95	•
RM T/V/W/X/Y/K1-K2	250	96	02	•
RMX K/L/M	250	89	91	•
RMX N/P	250	92	93	•
RMX R/S	250	94	95	•
RMX ST/SV/SW/SX	250	96	99	•
RMX T/V/W	250	96	98	•

Note

A series of horizontal dotted lines for writing notes.



Note

A series of horizontal dotted lines for writing notes, spanning the width of the page.





Handwriting practice lines consisting of 20 horizontal dotted lines.







UNI EN
ISO
9001:2008
Cert. N.
DE-30700310
QM08



adigeTM
RACING PARTS ITALY

DISTRIBUITO DA

Motorparts S.p.A.

Via Aldina, 26
40012 Lippo di Calderara di Reno (BO)
Tel. +39 051 725442 - fax +39 051 725449
www.motorparts.it