



COMPANY WITH QUALITY MANAGEMENT
SYSTEM CERTIFIED BY DNV
= ISO 9001:2008 =



Heavy Duty: 5000 kg

KPN250LIKA / 5000 kg

Equipaggiato con **4 bracci lunghi**: ideali per il sollevamento di **furgoni e furgonati a passo lungo**, consentono allo stesso tempo caricabilità ottimale anche per le autovetture.

*Model equipped with **four long arms**: ideal to lift long wheel-base vans and easy lifting of cars.*

Ausgestattet mit **vier langen Armen**: ideal zum Heben von Lieferwagen auch mit langem Radstand und garantiert auch eine optimale Aufnahme von PKW.

*Equipé de **quatre bras longs**: idéal pour le levage de fourgons à châssis long, il garantit aussi le levage optimal des voitures.*

Equipado con **4 brazos largos**: ideal sea para el levantamiento de furgonetas normales y de chasis largo sea de turismo.

Due bracci lunghi a 3 stadi e due a 4 stadi. I bracci scorrono sui rulli montati su molle: permettono di sfilarli agevolmente e scompaiono sotto carico.

Two long 3-stage and two long 4-stage arms. The arms' extensions slide on spring-mounted rollers, allowing easy use and a steady load.

Zwei zweifach und zwei dreifach ausziehbaren langen Armen. Die Arme laufen auf Rollen, die auf Federn montiert sind: diese erleichtern das Ausziehen der Arme und schwinden unter Last.

Deux bras longs à 3 étages et deux à 4 étages. Les rallonges des bras se déplacent sur des rouleaux montés sur ressorts, permettant un réglage facile - ces rouleaux se dégagent sous la charge.

Dos brazos largos de 3 extensiones y dos de 4 extensiones. Los brazos corren sobre rodillos montados encima de muelles: facilitan sus extensiones y desaparecen bajo carga.



KPN 250 LIKA

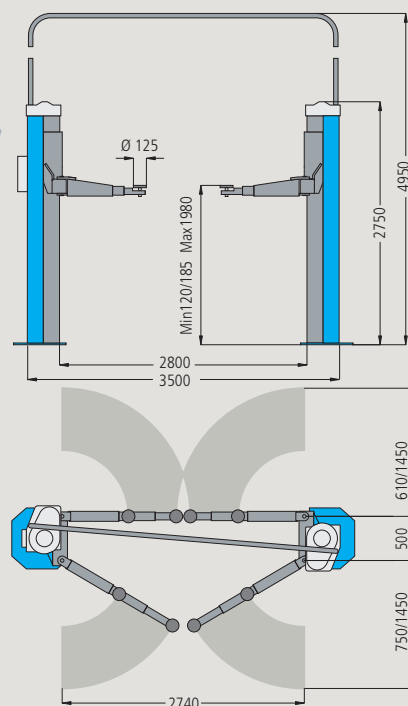

Altezza minima dei tamponi di 120 mm per il caricamento asimmetrico di **auto ammiraglie in versione blindata**.

*Minimum pad height of 120 mm for the asymmetric lifting of **armoured vehicles**.*

Minimal Unterschwenkhöhe von 120 mm zum Anheben von **gepanzerten Fahrzeugen**.

*Hauteur mini. des tampons de 120 mm pour le chargement asymétrique de véhicules **haut de gamme en version blindée**.*

Altura mínima de los tacos de 120 mm para elevar vehículos como los **modelos blindados** de varios constructores.

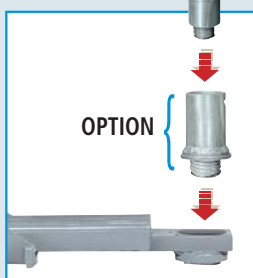

Quick fit system



Extra Long

KPN250LIKT / 5000 kg

Modello equipaggiato con **4 bracci extra lunghi a tre stadi: ideali per il sollevamento di furgoni e furgonati a passo lungo** incluso Mercedes Sprinter e VW Crafter.

Model equipped with **four extra long three-stage arms: ideal to lift long wheel-base vans** like Mercedes Sprinter and VW Crafter.

Modell mit **vier zweifach ausziehbaren extra langen Armen ausgestattet: ideal zum Heben von Lieferwagen auch mit langem Radstand** wie Mercedes Sprinter and VW Crafter.

Élévateur équipé de **quatre bras extra longs à 3 étages: idéal pour le levage de fourgons à châssis long** inclus les Mercedes Sprinter and VW Crafter.

Modelo equipado con **4 brazos extra largos de tres extensiones: ideal sea para el levantamiento de furgonetas normales y de chasis largo** incluido Mercedes Sprinter and VW Crafter.



OPTIONS

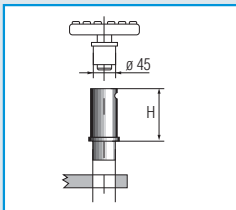

S 224 A3 (H=80mm)
S 224 A4 (H=140mm)

Distanziali per Fiat Ducato, Peugeot Boxer, Citroën Jumper (4 pezzi)

Spacers for Fiat Ducato, Peugeot Boxer, Citroën Jumper (4 pcs)

Abstandstücke für Fiat Ducato, Peugeot Boxer, Citroën Jumper (4 Stücke)

Rehausses pour Fiat Ducato, Peugeot Boxer, Citroën Jumper (4 pièces)

Espesores para Fiat Ducato, Peugeot Boxer, Citroën Jumper (4 piezas)

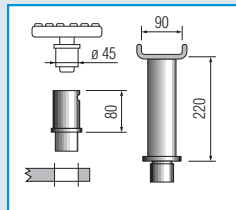

S 305 A9

Distanziali per Mercedes Sprinter, VW LT e Ford Transit (2+2 pezzi)

Spacers for Mercedes Sprinter, VW LT and Ford Transit (2+2 pcs)

Abstandstücke für Mercedes Sprinter, VW LT und Ford Transit (2+2 Stücke)

Rehausses pour Mercedes Sprinter, VW LT et Ford Transit (2+2 pièces)

Espesores para Mercedes Sprinter, VW LT y Ford Transit (2+2 piezas)

