



Malaguti

IDEE IN MOTO

XSM 50 SUPERMOTARD KAT EURO 2



TELAIO - INDICE TAVOLE

FRAME - INDEX OF THE TABLES

TAV. A 	TAV. A1 	TAV. B 	TAV. C 	TAV. D
TAV. E 	TAV. F 	TAV. G 	TAV. H 	TAV. I
TAV. L 	TAV. M 	TAV. N 	TAV. OO 	

MOTORE - INDICE TAVOLE

ENGINE - INDEX OF THE TABLES

TAV. R 	TAV. R1 			
-------------------	--------------------	--	--	--

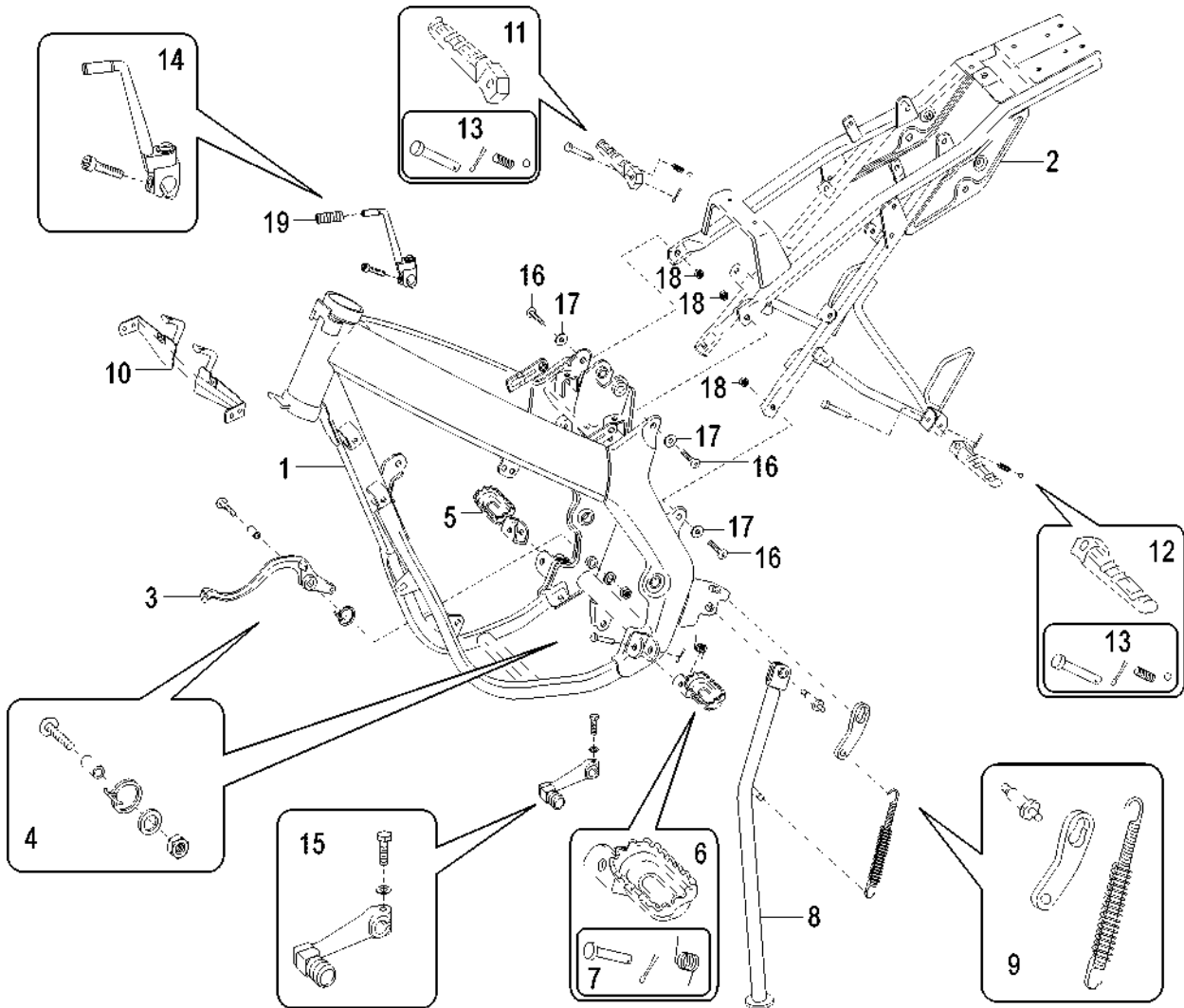
Telaio anteriore e posteriore
Front frame & rear

Nr.	Codice	Q.tà	Descrizione
1	156.103.99	1	Telaio anteriore
2	156.102.99	1	Telaio posteriore
3	152.023.00	1	Pedale freno
4	150.319.00	1	Kit fissaggio pedale freno
5	084.044.00	1	Poggiapiedi dx pilota completo
6	084.045.00	1	Poggiapiedi sx pilota completo
7	150.316.00	2	Kit fissaggio poggiapiedi pilota
8	159.043.99	1	Cavalletto laterale
9	150.318.00	1	Kit fissaggio cavalletto laterale
10	191.075.00	1	Supporto frecce e mascherina faro
11	084.046.00	1	Poggiapiedi dx passegg. completo
12	084.047.00	1	Poggiapiedi sx passegg. completo
13	150.317.00	2	Kit fissaggio poggiapiedi passegg.
14	081.013.00	1	Leva messa in moto
15	082.010.00	1	Leva cambio
16	184.257.00	4	Vite
17	184.266.13	4	Rondella
18	185.024.14	4	Dado
19	072.181.00	1	Gommino leva messa in moto

Nr.	Code	Q.ty	Description
1	156.103.99	1	Front frame
2	156.102.99	1	Rear frame
3	152.023.00	1	Lever brake pedal
4	150.319.00	1	Lever brake pedal fixing kit
5	084.044.00	1	R/h front bracket footrest assy
6	084.045.00	1	L/h front bracket footrest assy
7	150.316.00	2	L/h-R/h footrest fixing kit
8	159.043.99	1	Side stand
9	150.318.00	1	Side stand fixing kit
10	191.075.00	1	Headlight and flasher bracket
11	084.046.00	1	R/h rear bracket footrest assy
12	084.047.00	1	L/h rear bracket footrest assy
13	150.317.00	2	L/h-R/h footrest fixing kit
14	081.013.00	1	Kick starter lever
15	082.010.00	1	Gear lever
16	184.257.00	4	Screw
17	184.266.13	4	Washer
18	185.024.14	4	Nut
19	072.181.00	1	Kick starter rubber

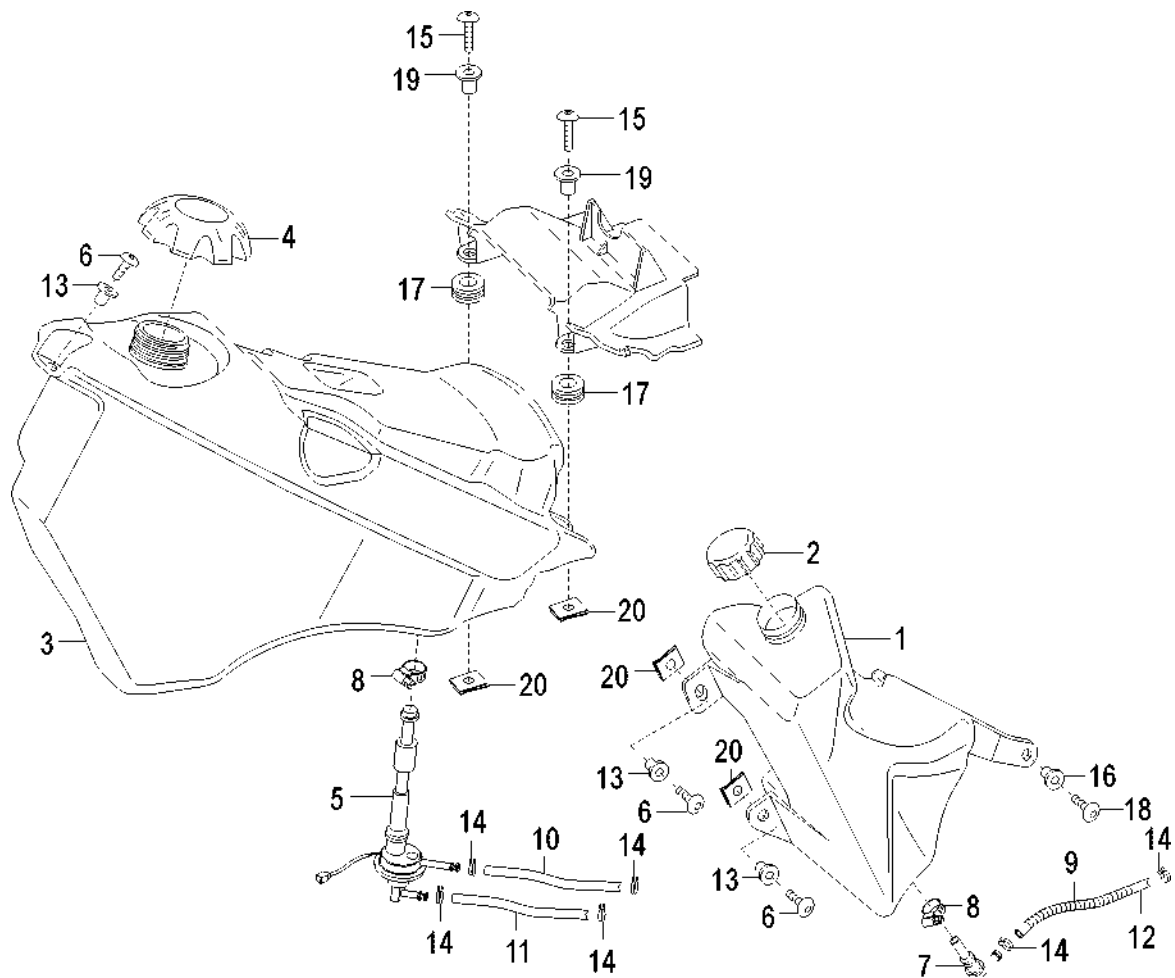
Serbatoio benzina & olio
Fuel tank & oil tank

Nr.	Codice	Q.tà	Descrizione
1	069.021.00	1	Serbatoio olio
2	071.509.00	1	Tappo serbatoio olio
3	161.071.03	1	Serbatoio benzina
4	092.032.00	1	Tappo serbatoio benzina
5	093.080.00	1	Rubinetto benzina depressione
6	184.254.15	3	Vite
7	094.029.00	1	Raccordo olio con filtro
8	167.031.00	2	Fascetta
9	147.084.13	1	Molla protezione tubo benzina
10	180.010.66	1	Tubo benzina
11	180.003.62	2	Tubo depressione
12	180.003.63	1	Tubo olio
13	150.148.14	3	Boccola
14	167.018.13	6	Fascetta stringitubo
15	184.255.15	2	Vite
16	150.310.13	1	Boccola
17	072.161.00	2	Gommino fissaggio serbatoio
18	184.060.15	1	Vite
19	150.210.13	2	Boccola
20	184.201.00	4	Prestola M 6

Nr.	Code	Q.ty	Description
1	069.021.00	1	Oil tank
2	071.509.00	1	Oil tank cap
3	161.071.03	1	Fuel tank
4	092.032.00	1	Fuel tank cap
5	093.080.00	1	Fuel pet cock
6	184.254.15	3	Screw
7	094.029.00	1	Oil pipe connector
8	167.031.00	2	Clamp
9	147.084.13	1	Pipe spring
10	180.010.66	1	Fuel hose
11	180.003.62	2	Depression hose
12	180.003.63	1	Oil hose
13	150.148.14	3	Collar
14	167.018.13	6	Clamp
15	184.255.15	2	Screw
16	150.310.13	1	Collar
17	072.161.00	2	Rubber grommet
18	184.060.15	1	Screw
19	150.210.13	2	Collar
20	184.201.00	4	Clamp

Impianto di raffreddamento Cooling system

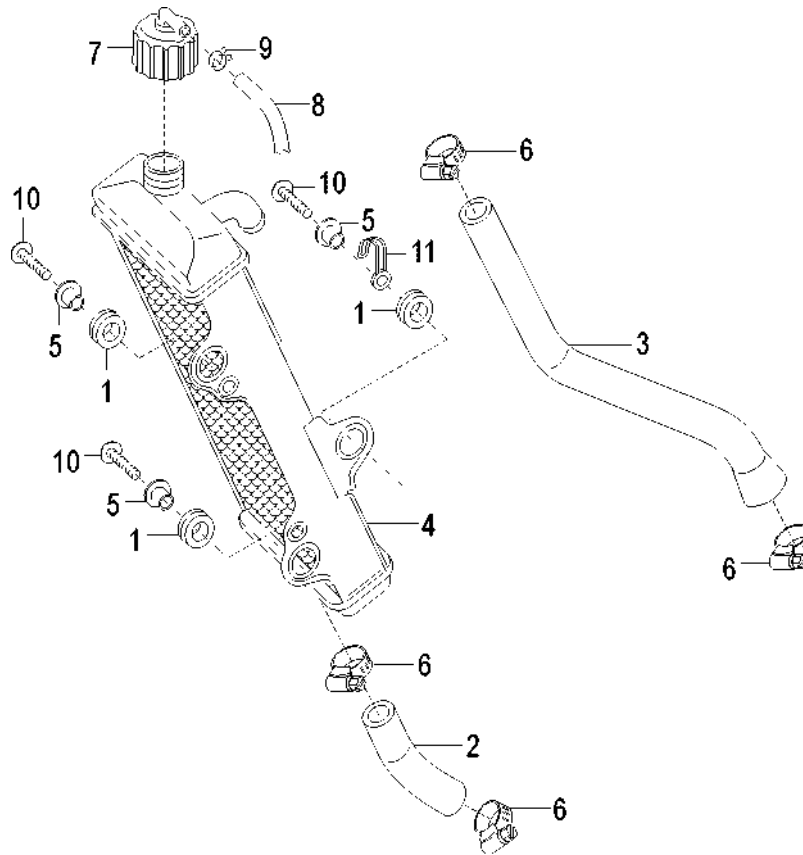

Nr.	Codice	Q.tà	Descrizione
1	072.161.00	3	Gommino fissaggio radiatore
2	077.052.00	1	Tubo radiatore inferiore
3	077.053.00	1	Tubo radiatore superiore
4	108.046.00	1	Radiatore acqua
5	150.305.13	3	Boccola fissaggio radiatore
6	167.031.00	4	Fascetta stringitubo
7	071.219.03	1	Tappo radiatore
8	180.002.59	1	Tubo sfiato radiatore
9	167.018.13	1	Fascetta stringitubo
10	184.060.15	3	Vite
11	167.039.00	1	Fascetta ferma cablaggio

Nr.	Code	Q.ty	Description
1	072.161.00	3	Rubber grommet
2	077.052.00	1	Return pipe
3	077.053.00	1	Delivery pipe
4	108.046.00	1	Water cooler
5	150.305.13	3	Bush
6	167.031.00	4	Clamp
7	071.219.03	1	Water cooler cap
8	180.002.59	1	Water cooler breather pipe
9	167.018.13	1	Clamp
10	184.060.15	3	Screw
11	167.039.00	1	Clamp

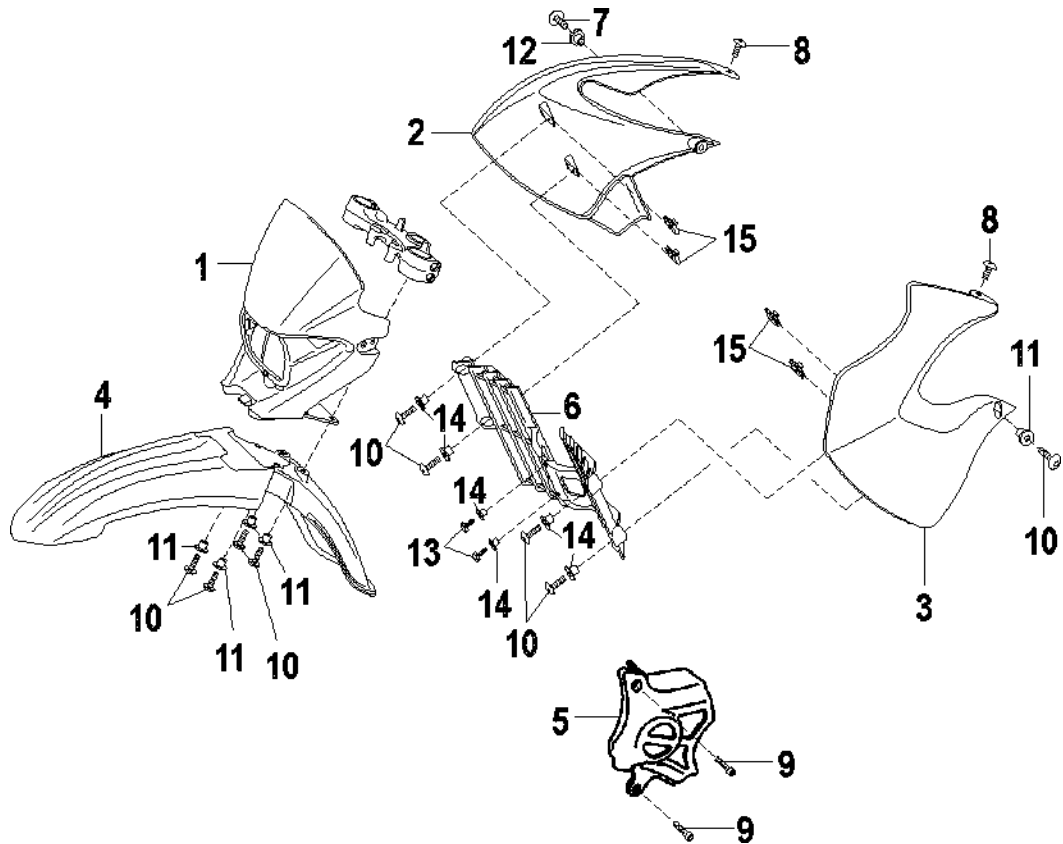
Carrozzeria anteriore
Front body

Nr.	Codice	Q.tà	Descrizione
1	058.049. --	1	Mascherina portafanale *
2	062.072. --	1	Convogliatore radiatore dx *
3	062.073. --	1	Convogliatore radiatore sx *
4	055.064. --	1	Parafango anteriore *
5	061.074.00	1	Carter copripignone
6	071.506.03	1	Griglia radiatore
7	184.254.15	1	Vite
8	184.253.15	4	Vite
9	184.260.15	2	Vite
10	184.060.15	9	Vite
11	150.310.13	6	Boccola
12	150.148.14	1	Boccola
13	184.171.15	2	Vite
14	150.305.13	6	Boccola
15	184.201.00	4	Prestola M 6
--	181.370. --	1	Serie marche XSM 50 SuperMotard *

Nr.	Code	Q.ty	Description
1	058.049. --	1	Headlight housing *
2	062.072. --	1	R/h side cover *
3	062.073. --	1	L/h side cover *
4	055.064. --	1	Front mudguard *
5	061.074.00	1	Chain sprocket cover
6	071.506.03	1	Water cooler grid
7	184.254.15	1	Screw
8	184.253.15	4	Screw
9	184.260.15	2	Screw
10	184.060.15	9	Screw
11	150.310.13	6	Collar
12	150.148.14	1	Collar
13	184.171.15	2	Screw
14	150.305.13	6	Collar
15	184.201.00	4	Clamp
--	181.370. --	1	XSM 50 SuperMotard label set *

* Vedi tav. N° OO Colori

* Refer to N° OO Colour table

Carrozzeria posteriore Rear body

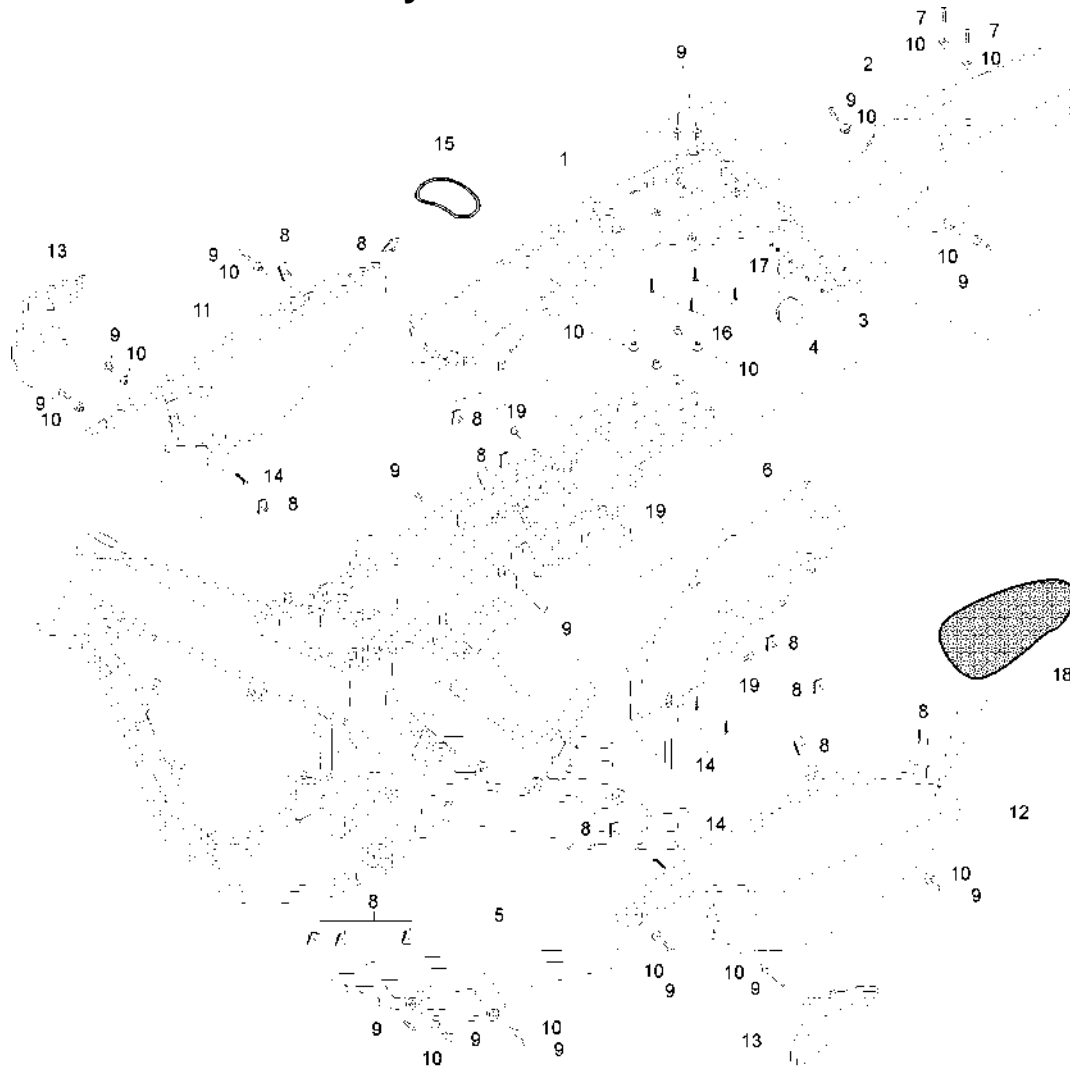

Nr.	Codice	Q.tà	Descrizione
1	057.065.03	1	Codino portatarga + porta batteria
2	056.075. --	1	Parafango posteriore *
3	071.117.01	1	Catadiottro rosso
4	071.225.00	2	Catadiottro ambra
5	061.075.00	1	Carter copricatena
6	071.543.03	1	Bancalina protezione ammortizzatore
7	184.060.15	2	Vite
8	184.201.00	13	Prestola M 6
9	184.254.15	18	Vite
10	150.148.14	16	Boccola
11	060.114. --	1	Portanumero laterale dx *
12	060.115. --	1	Portanumero laterale sx * + protezione
13	071.523.03	1	Cp. appendici portanumeri laterali
14	184.041.15	6	Vite
15	072.167.00	1	Elastico fissaggio batteria
16	184.067.13	4	Vite
17	184.099.13	2	Dado
18	072.179.00	1	Protezione termica
19	184.253.15	3	Vite
--	181.370. --	1	Serie marche XSM 50 SuperMotard *

Nr.	Code	Q.ty	Description
1	057.065.03	1	License plate mudguard tail
2	056.075. --	1	Rear mudguard *
3	071.117.01	1	Red reflector
4	071.225.00	2	Amber reflector
5	061.075.00	1	Chain guard
6	071.543.03	1	Shock absorber protection
7	184.060.15	2	Screw
8	184.201.00	13	Clamp
9	184.254.15	18	Screw
10	150.148.14	16	Collar
11	060.114. --	1	R/h number holder *
12	060.115. --	1	L/h number holder * + protection
13	071.523.03	1	Number plate holder, pair
14	184.041.15	6	Screw
15	072.167.00	1	Battery fixing belt
16	184.067.13	4	Screw
17	184.099.13	2	Nut
18	072.179.00	1	Thermic protection
19	184.253.15	3	Screw
--	181.370. --	1	XSM 50 SuperMotard label set *

* Vedi tav. N° OO Colori

* Refer to N° OO Colour table

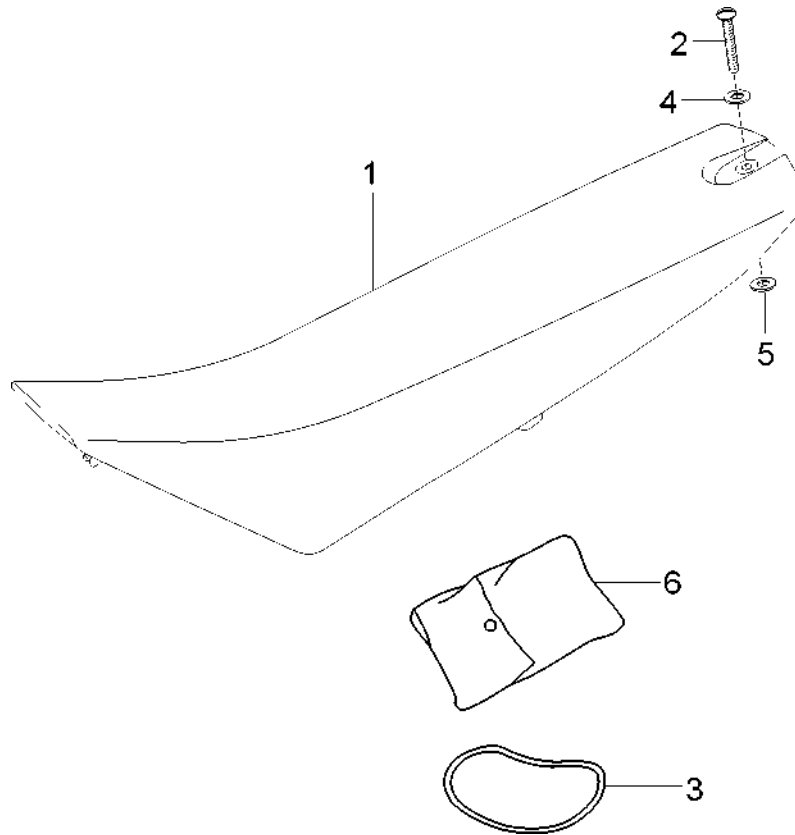
**Gruppo sella
 Seat assy**

Nr.	Codice	Q.tà	Descrizione
1	106.098. --	1	Sellone completo *
2	184.259.00	1	Vite fissaggio sella
3	072.167.00	1	Elastico fissaggio kit attrezzi
4	184.268.00	1	Rondella superiore
5	184.267.00	1	Rondella inferiore
6	086.056.14	1	Trousse attrezzi

Nr.	Code	Q.ty	Description
1	106.098. --	1	Seat assy *
2	184.259.00	1	Seat fixing screw
3	072.167.00	1	Tool kit fixing belt
4	184.268.00	1	Upper washer
5	184.267.00	1	Lower washer
6	086.056.14	1	Tools kit

* Vedi tav. N° OO Colori

* Refer to N° OO Colour table

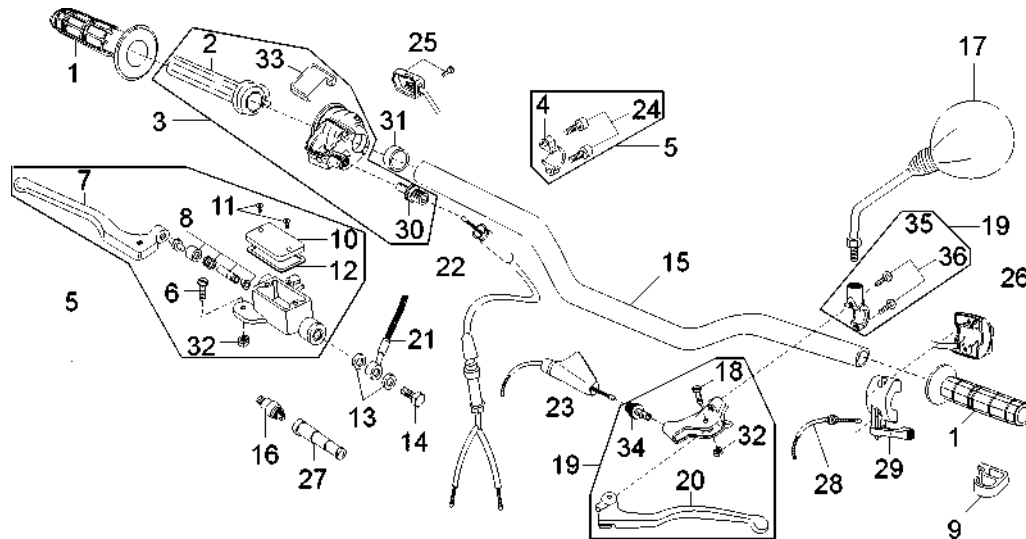
**Manubrio e comandi
 Handlebar & controls**

Nr.	Codice	Q.tà	Descrizione
1	097.022.03	1	Kit manopole (dx + sx)
2	121.160.00	1	Tubo comando gas
3	028.023.00	1	Comando gas senza manopole
4	121.155.00	1	Attacco pompa freno dx
5	030.028.03	1	Pompa freno completa + attacco
6	121.157.00	1	Vite fulcro leva freno dx
7	121.164.03	1	Leva freno dx
8	121.161.00	1	Pistone completo
9	071.532.00	1	Guida trasmissione idraulica
10	121.156.00	1	Coperchio pompa freno
11	184.179.00	2	Vite coperchio pompa freno
12	121.159.00	1	Guarnizione coperchio pompa freno
13	190.006.00	2	Rasamento
14	150.024.14	1	Vite trasmissione idraulica
15	162.046.13	1	Manubrio senza traversino
16	021.026.00	1	Interruttore stop leva freno dx
17	088.042.03	1	Specchio sx
18	121.162.00	1	Vite fulcro leva frizione sx
19	121.153.00	1	Comando frizione sx completo
20	121.163.03	1	Leva frizione sx
21	033.055.00	1	Trasmissione idraulica
22	034.102.03	1	Trasmissione gas con sdoppiatore
23	048.040.03	1	Trasmissione frizione
24	184.247.00	2	Vite attacco pompa freno
25	020.067.00	1	Commutatore dx MODE

Nr.	Code	Q.ty	Description
1	097.022.03	1	Handgrip set
2	121.160.00	1	Throttle twist grip
3	028.023.00	1	Twist grip tube w/o handgrip set
4	121.155.00	1	R/h front brake pump bracket
5	030.028.03	1	R/h master cylinder assy
6	121.157.00	1	Lever bolt, r/h
7	121.164.03	1	R/h brake lever
8	121.161.00	1	Master cylinder assy
9	071.532.00	1	Hydraulic brake hose fixing
10	121.156.00	1	Pump cover
11	184.179.00	2	Pump cover screw
12	121.159.00	1	Pump cover gasket
13	190.006.00	2	Copper banjo washer
14	150.024.14	1	Brake hose bolt
15	162.046.13	1	Handlebar
16	021.026.00	1	Stop switch
17	088.042.03	1	L/h mirror
18	121.162.00	1	Lever bolt, l/h
19	121.153.00	1	L/h clutch control assy
20	121.163.03	1	Clutch lever
21	033.055.00	1	Front hydraulic brake hose
22	034.102.03	1	Throttle cable
23	048.040.03	1	Clutch cable
24	184.247.00	2	Screw
25	020.067.00	1	R/h switch with MODE

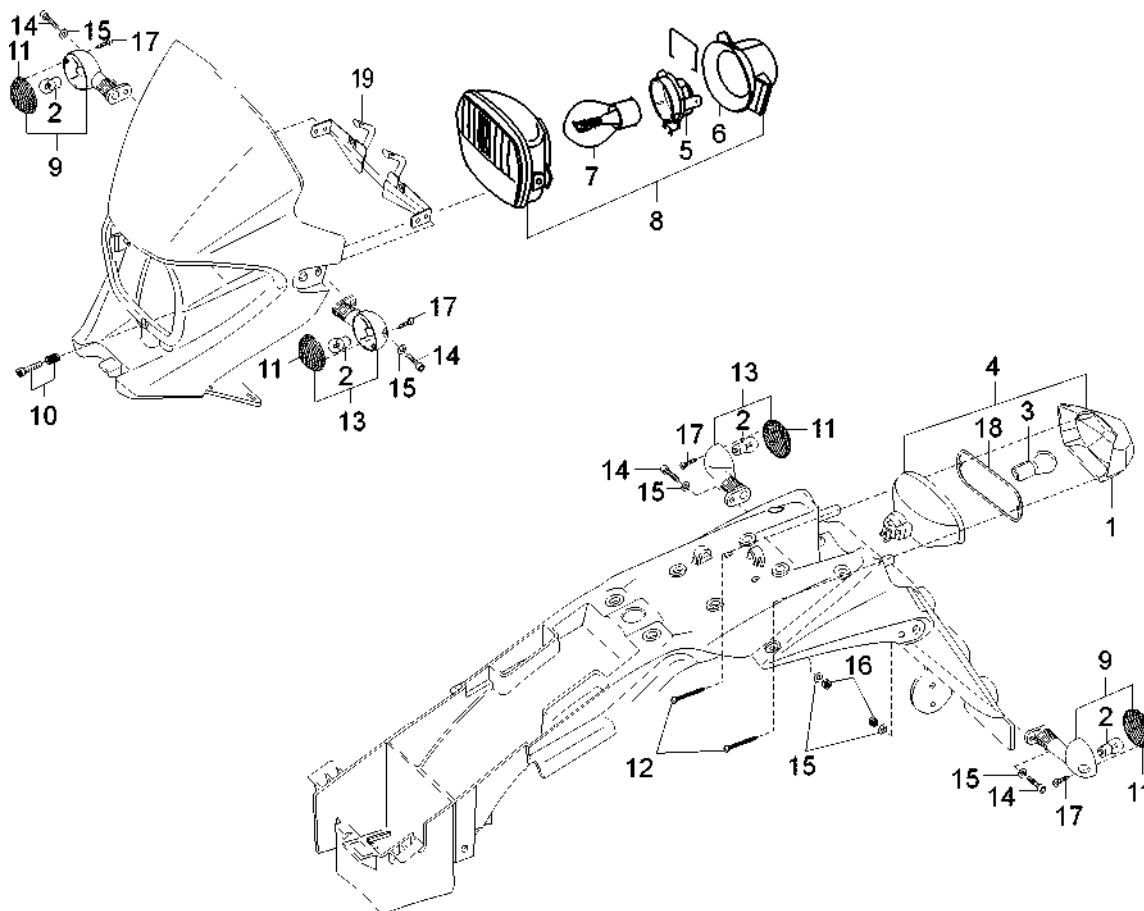
Impianto elettrico
Electrical system

Nr.	Codice	Q.tà	Descrizione
1	016.073.00	1	Vetro fanalino posteriore
2	022.017.00	4	Lampadina 12 V - 10 W
3	022.048.00	1	Lampadina 12 V - 5 / 21 W
4	016.072.00	1	Fanalino posteriore
5	023.021.00	1	Portalampada biluce
6	072.178.00	1	Cappuccio faro
7	022.061.00	1	Lampadina 12 V - 35 / 35 W
8	015.055.00	1	Faro anteriore
9	019.097.00	2	Indicatore direzione dx
10	190.062.00	1	Kit regolazione faro
11	019.099.00	4	Vetro indicatori sx / dx
12	184.157.00	2	Vite fanalino posteriore
13	019.098.00	2	Indicatore direzione sx
14	184.104.13	4	Vite
15	184.051.13	6	Rondella
16	184.078.13	2	Dado
17	184.118.15	4	Vite
18	072.182.00	1	Guarnizione fanale posteriore
19	191.075.00	1	Supporto frecce e mascherina faro

Nr.	Code	Q.ty	Description
1	016.073.00	1	Tail light lens
2	022.017.00	4	12 V - 10 W bulb
3	022.048.00	1	12 V - 5 / 21 W bulb
4	016.072.00	1	Tail light assy
5	023.021.00	1	Headlight bulb socket
6	072.178.00	1	Headlight rubber cap
7	022.061.00	1	12 V - 35 / 35 W bulb
8	015.055.00	1	Headlight assy
9	019.097.00	2	R/h indicator assy
10	190.062.00	1	Headlight adjusting kit
11	019.099.00	4	R/h - L/h indicator lens
12	184.157.00	2	Tail light screw
13	019.098.00	2	L/h indicator assy
14	184.104.13	4	Screw
15	184.051.13	6	Washer
16	184.078.13	2	Nut
17	184.118.15	4	Screw
18	072.182.00	1	Gasket
19	191.075.00	1	Headlight and flasher bracket

Impianto elettrico Electrical system



Nr.	Codice	Q.tà	Descrizione
1	196.146.00	1	Cruscotto digitale
2	150.210.13	2	Boccola fissaggio cruscotto
3	184.270.15	2	Vite fissaggio cruscotto
4	020.066.00	1	Commutatore di avviamento
5	073.007.00	1	Pipetta candela con cappuccio
6	024.022.00	1	Centralina CDI
7	093.032.00	1	Sonda livello olio
8	026.021.00	1	Regolatore
9	025.041.00	1	Intermittenza
10	025.010.00	1	Fusibile 10 A
11	074.022.00	1	Batteria 12 V - 4 Ah
12	018.073.00	1	Avvisatore acustico
13	017.360.00	1	Cablaggio centrale
14	184.273.00	2	Vite antimanomissione
15	086.066.00	1	Chiave vite antimanomissione 1° serie
16	167.039.00	3	Fascetta ferma cablaggio
17	021.025.00	1	Interruttore stop posteriore
18	021.026.00	1	Interruttore stop anteriore
19	021.027.00	1	Bulbo temperatura acqua
20	093.080.00	1	Rubinetto benzina
21	071.542.03	1	Fermacavi frecce posteriori
22	184.078.13	3	Dado
23	184.253.15	1	Vite
24	184.258.00	2	Vite
25	184.051.13	4	Rondella

Nr.	Code	Q.ty	Description
1	196.146.00	1	Digital dashboard
2	150.210.13	2	Bush
3	184.270.15	2	Screw
4	020.066.00	1	Main switch
5	073.007.00	1	Spark plug cap
6	024.022.00	1	CDI
7	093.032.00	1	Oil level gauge
8	026.021.00	1	Regulator
9	025.041.00	1	Flasher relay
10	025.010.00	1	10 A fuse
11	074.022.00	1	12 V - 4 Ah battery
12	018.073.00	1	Horn
13	017.360.00	1	Main switch harness
14	184.273.00	2	Antitampering screw
15	086.066.00	1	Antitampering screw spanner 1° sr.
16	167.039.00	3	Clamp
17	021.025.00	1	Stop switch, rear
18	021.026.00	1	Stop switch, front
19	021.027.00	1	Water temperature sender
20	093.080.00	1	Fuel pet cock
21	071.542.03	1	Rear indicator harness clamp
22	184.078.13	3	Nut
23	184.253.15	1	Screw
24	184.258.00	2	Screw
25	184.051.13	4	Washer

Impianto elettrico
Electrical system

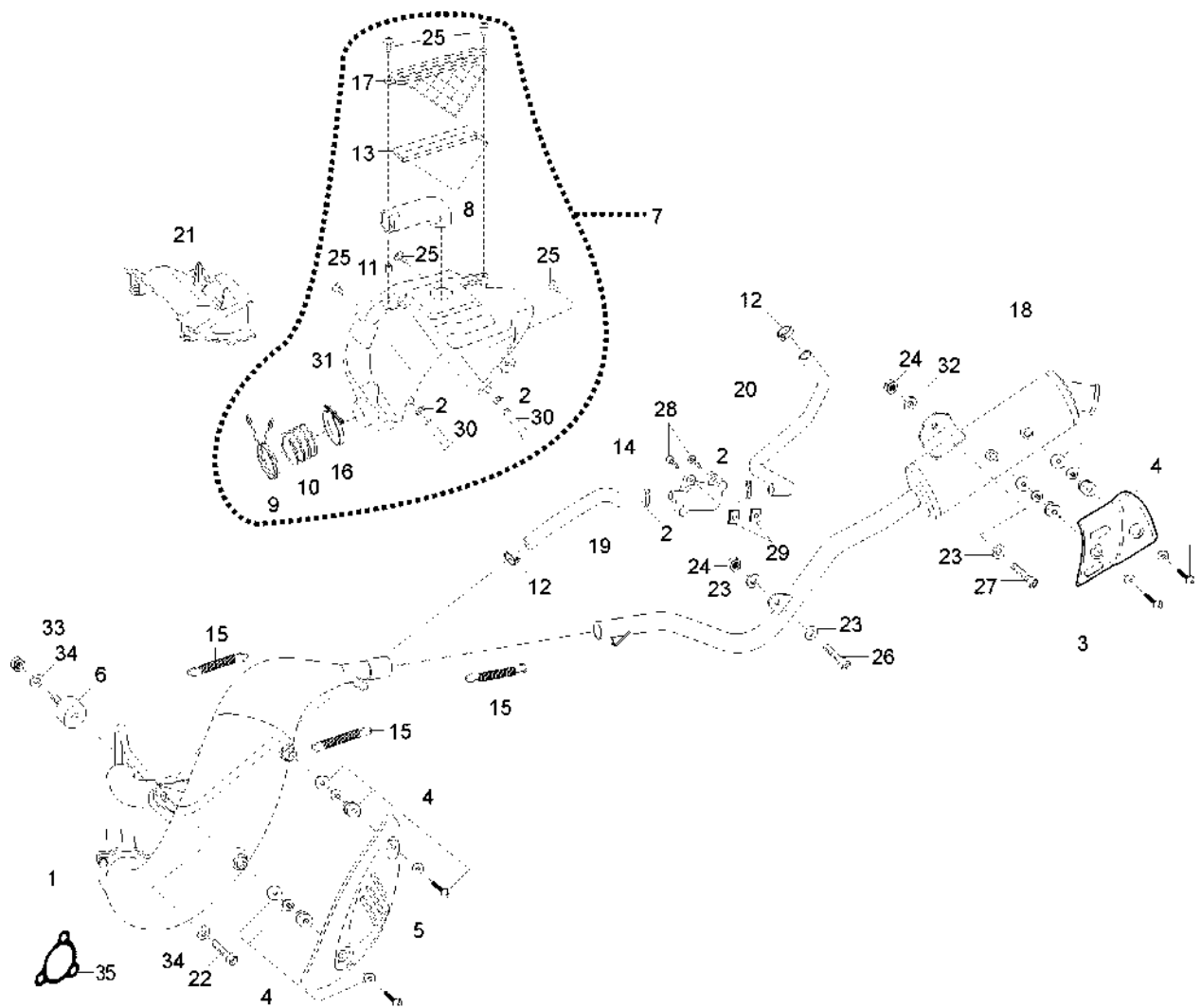

Nr.	Codice	Q.tà	Descrizione
26	184.171.15	2	Vite
27	184.036.13	1	Vite
28	184.047.15	2	Vite
29	184.201.00	1	Prestola M 6
30	080.002.00	2	Gommino
31	184.060.15	1	Vite

Nr.	Code	Q.ty	Description
26	184.171.15	2	Screw
27	184.036.13	1	Screw
28	184.047.15	2	Screw
29	184.201.00	1	Clamp
30	080.002.00	2	Rubber grommet
31	184.060.15	1	Screw

Gruppo scarico e aspirazione
Exhaust assembly

Nr.	Codice	Q.tà	Descrizione
1	165.202.99	1	Marmitta catalitica
2	167.018.13	2	Fascetta stringitubo
3	071.546.16	1	Protezione silenziatore
4	150.320.00	4	Kit fissaggio griglia
5	071.545.03	1	Protezione marmitta
6	075.042.00	1	Silentblock marmitta
7	066.139.03	1	Cassetta filtro completa
8	076.037.00	1	Manicotto cassetta aspirazione
9	147.157.13	1	Molla manicotto aspirazione
10	076.035.00	1	Manicotto aspirazione al carburatore
11	075.028.00	1	Boccola
12	167.049.00	2	Fascetta
13	066.140.00	1	Filtro aspirazione
14	094.023.00	1	Valvola aria AIS
15	147.026.14	3	Molla scarico
16	167.061.00	1	Fascetta manicotto aspirazione
17	066.142.03	1	Coperchio cassetta filtro
18	166.046.99	1	Silenziatore scarico
19	180.061.00	1	Tubo marmitta - valvola
20	180.062.00	1	Tubo valvola - cassetta filtro
21	071.544.03	1	Protezione cassetta aspirazione
22	184.272.13	1	Vite silentblock marmitta
23	184.264.13	3	Rondella
24	184.078.13	2	Dado
25	184.254.15	5	Vite

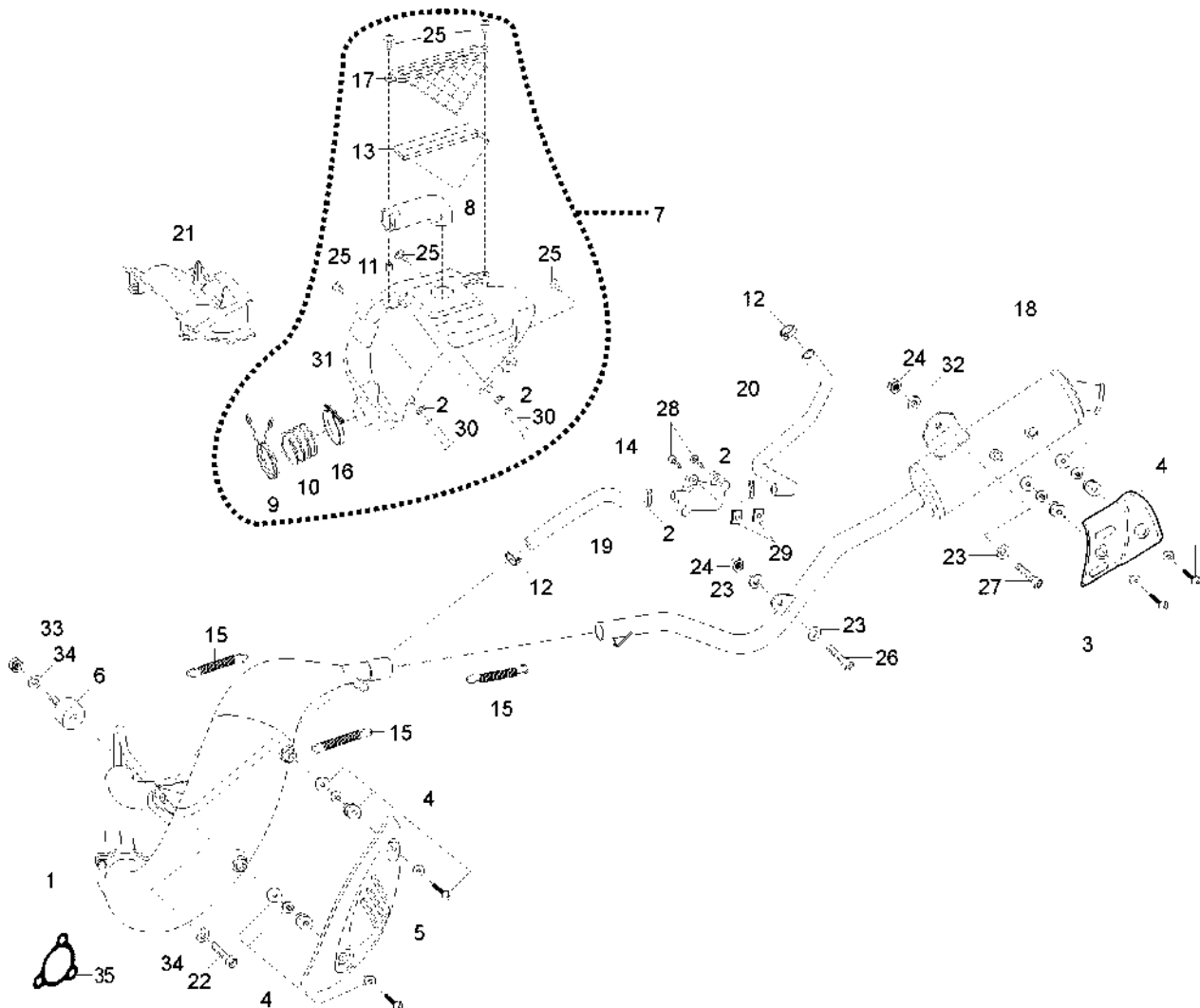
Nr.	Code	Q.ty	Description
1	165.202.99	1	Kat - exhaust system assy
2	167.018.13	2	Clamp
3	071.546.16	1	Silencer heat shield
4	150.320.00	4	Heat shield fixing screw
5	071.545.03	1	Exhaust heat shield
6	075.042.00	1	Exhaust silentblock
7	066.139.03	1	Air box assy
8	076.037.00	1	Air box intake sleeve
9	147.157.13	1	Air box spring clip
10	076.035.00	1	Air box carb. sleeve
11	075.028.00	1	Collar
12	167.049.00	2	Clamp
13	066.140.00	1	Air filter
14	094.023.00	1	AIS air valve
15	147.026.14	3	Exhaust spring
16	167.061.00	1	Clamp
17	066.142.03	1	Air box cover
18	166.046.99	1	Kat - silencer assy
19	180.061.00	1	Hose (exhaust - valve)
20	180.062.00	1	Hose (valve - air box)
21	071.544.03	1	Air box protection
22	184.272.13	1	Screw
23	184.264.13	3	Washer
24	184.078.13	2	Nut
25	184.254.15	5	Screw

Gruppo scarico e aspirazione
Exhaust assembly

Nr.	Codice	Q.tà	Descrizione
26	184.104.13	1	Vite
27	184.106.13	1	Vite
28	184.035.15	1	Vite
29	184.152.00	2	Prestola M 5
30	180.002.60	2	Tubo benzina
31	066.143.03	1	Cassetta filtro
32	184.265.13	1	Rondella
33	184.148.13	1	Dado
34	184.077.13	2	Rondella
35	072.188.00	1	Guarnizione raccordo scarico-pancia

Nr.	Code	Q.ty	Description
26	184.104.13	1	Screw
27	184.106.13	1	Screw
28	184.035.15	1	Screw
29	184.152.00	1	Clamp
30	180.002.60	2	Fuel hose
31	066.143.03	1	Air box
32	184.265.13	1	Washer
33	184.148.13	1	Nut
34	184.077.13	2	Washer
35	072.188.00	1	Exhaust connecting gasket

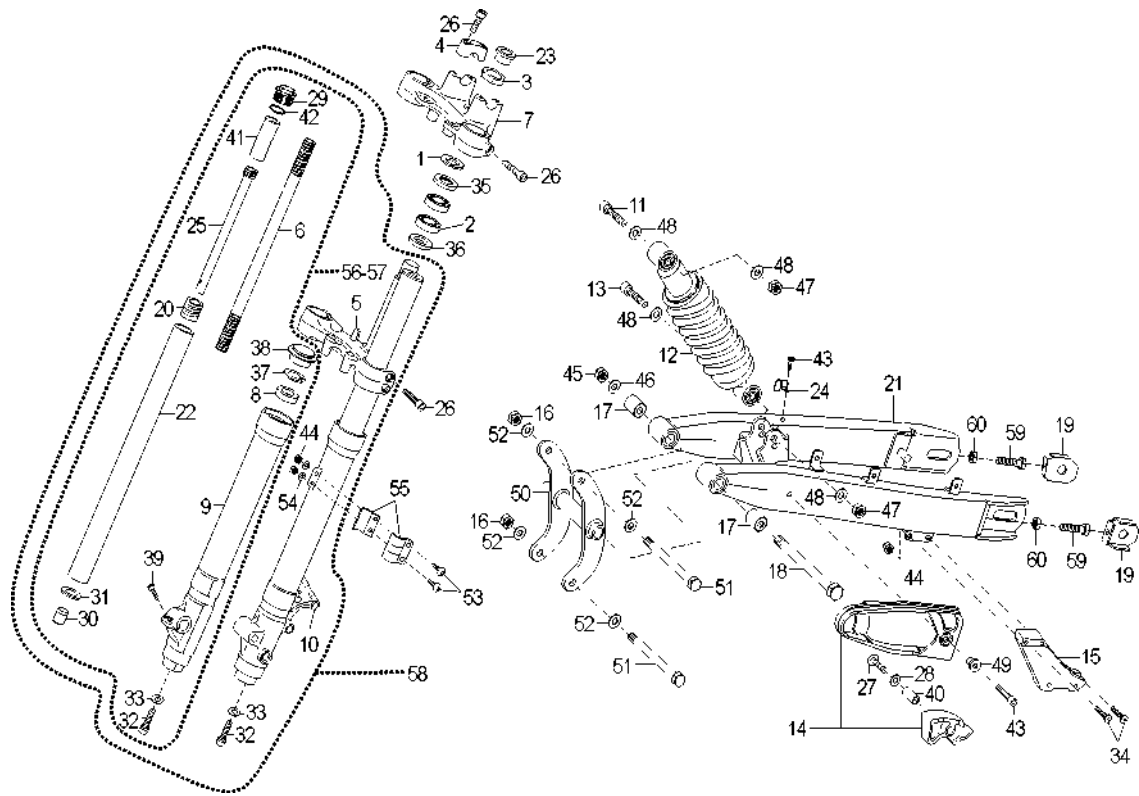
Sospensione anteriore e posteriore
Front & rear suspension

Nr.	Codice	Q.tà	Descrizione
-----	--------	------	-------------

1	185.119.00	1	Ghiera registro sterzo
2	104.040.00	2	Cuscinetto sterzo
3	185.120.00	1	Dado canotto sterzo
4	120.430.00	2	Morsetto superiore manubrio
5	120.428.00	1	Trapezio inferiore
6	120.449.00	2	Molla dx / sx
7	120.427.00	1	Trapezio superiore
8	120.447.00	2	Paraolio forcella
9	120.436.00	1	Fodero dx
10	120.435.00	1	Fodero sx
11	184.262.13	1	Vite fissaggio superiore
12	010.062.03	1	Ammortizzatore
13	184.182.13	1	Vite fissaggio inferiore
14	071.547.00	1	Pattino catena completo
15	071.517.00	1	Passacatena
16	184.148.13	3	Dado
17	075.040.00	2	Silentblock forcellone
18	100.019.13	1	Perno forcellone
19	189.021.00	1	Tendicatena
20	120.441.00	2	Molla fine corsa
21	157.071.99	1	Forcellone
22	120.433.00	2	Canna forcella dx / sx
23	120.429.00	1	Protezione canotto sterzo
24	167.059.00	2	Fascetta fissaggio tubo freno
25	120.444.00	2	Stelo pompante

Nr.	Code	Q.ty	Description
-----	------	------	-------------

1	185.119.00	1	Steering nut set
2	104.040.00	2	Steering head bearing
3	185.120.00	1	Steering nut
4	120.430.00	2	Handlebar holder clamp
5	120.428.00	1	Steering bottom yoke
6	120.449.00	2	Spring, R/h - L/h
7	120.427.00	1	Steering top yoke
8	120.447.00	2	Fork oil seal
9	120.436.00	1	R/h tube outer
10	120.435.00	1	L/h tube outer
11	184.262.13	1	Upper fixing screw
12	010.062.03	1	Shock absorber
13	184.182.13	1	Lower fixing screw
14	071.547.00	1	Chain sliding shoe assy
15	071.517.00	1	Chain guide
16	184.148.13	3	Nut
17	075.040.00	2	Swinging arm silentblock
18	100.019.13	1	Swinging arm pivot
19	189.021.00	1	Chain tightener
20	120.441.00	2	Spring
21	157.071.99	1	Swinging arm
22	120.433.00	2	Inner tube, R/h - L/h
23	120.429.00	1	Steering shaft plug
24	167.059.00	2	Brake hose fixing clamp
25	120.444.00	2	Piston tube

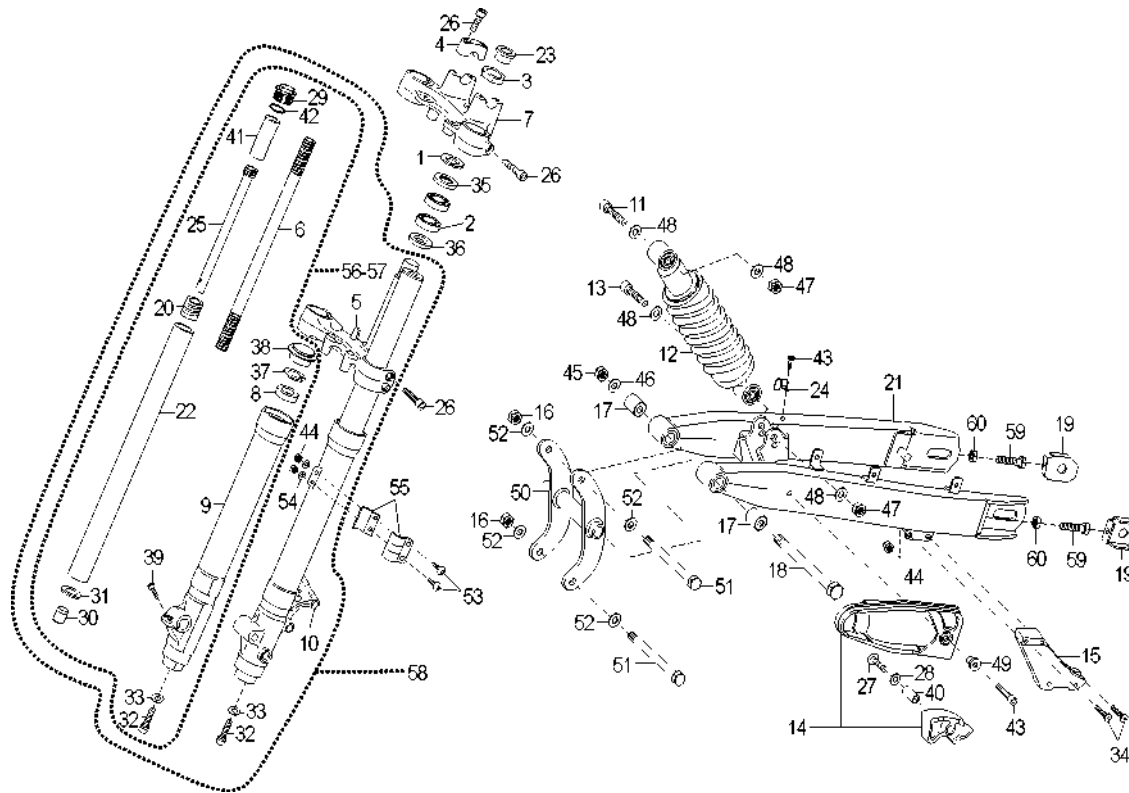

Nr.	Codice	Q.tà	Descrizione
26	184.248.00	10	Viti fissaggio trapezio
27	184.038.13	1	Vite
28	184.053.13	1	Rondella
29	120.431.00	2	Tappo tubo canna forcella
30	120.448.00	2	Cono fine corsa
31	184.252.00	2	Rondella cono fine corsa
32	184.250.00	2	Vite base cono
33	184.251.00	2	Rondella base cono
34	184.091.15	4	Vite passacatena
35	072.003.00	1	Parapolvere superiore
36	071.539.00	1	Parapolvere inferiore
37	120.446.00	2	Anello tenuta paraolio
38	120.445.00	2	Cuffia parapolvere
39	184.249.00	2	Vite base fodero
40	150.311.13	1	Distanziale pattino catena
41	120.457.00	2	Distanziale interno
42	120.432.00	2	O-Ring
43	184.171.15	2	Vite
44	184.078.13	6	Dado
45	185.010.00	1	Dado
46	119.224.00	1	Rondella
47	184.263.14	2	Dado
48	184.094.13	2	Rondella
49	150.148.14	1	Boccola
50	174.039.99	1	Attacco motore

Nr.	Code	Q.ty	Description
26	184.248.00	10	Fixing screw
27	184.038.13	1	Screw
28	184.053.13	1	Washer
29	120.431.00	2	Plug inner tube
30	120.448.00	2	Taper spindle
31	184.252.00	2	Washer
32	184.250.00	2	Screw
33	184.251.00	2	Washer
34	184.091.15	4	Screw
35	072.003.00	1	Dust seal upper
36	071.539.00	1	Dust seal lower
37	120.446.00	2	Clip oil seal
38	120.445.00	2	Dust seal
39	184.249.00	2	Screw
40	150.311.13	1	Chain slidin shoe spacer
41	120.457.00	2	Inner spacer
42	120.432.00	2	O-Ring
43	184.171.15	2	Screw
44	184.078.13	6	Nut
45	185.010.00	1	Nut
46	119.224.00	1	Washer
47	184.263.14	2	Nut
48	184.094.13	2	Washer
49	150.148.14	1	Collar
50	174.039.99	1	Engine bracket

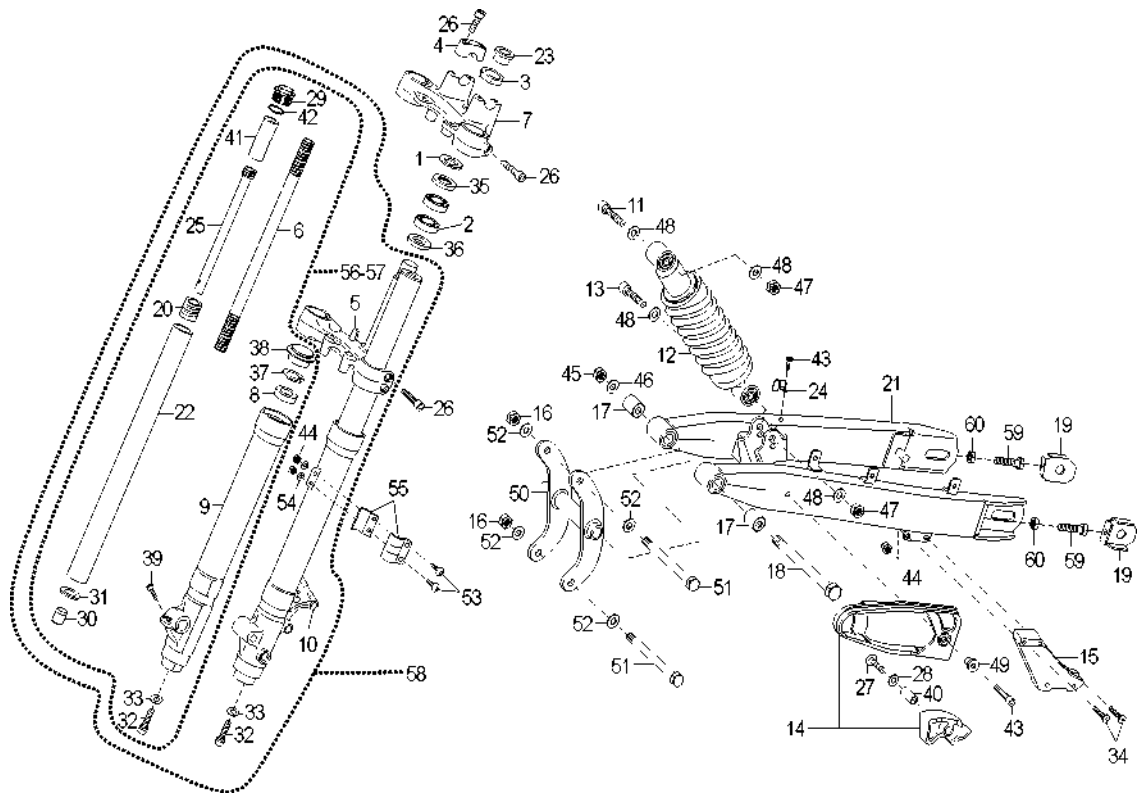

Nr.	Codice	Q.tà	Descrizione
51	184.261.13	3	Vite
52	184.053.13	6	Rondella
53	184.255.15	2	Vite
54	184.051.13	2	Rondella
55	071.097.03	1	Fissaggio trasmissione idraulica
56	120.450.00	1	Portaruota dx
57	120.451.00	1	Portaruota sx
58	013.055.50	1	Forcella idraulica
59	184.271.13	2	Vite
60	184.145.13	2	Dado

Nr.	Code	Q.ty	Description
51	184.261.13	3	Screw
52	184.053.13	6	Washer
53	184.255.15	2	Screw
54	184.051.13	2	Washer
55	071.097.03	1	Hydraulic brake hose fixing
56	120.450.00	1	Fork leg assy, r/h
57	120.451.00	1	Fork leg assy, l/h
58	013.055.50	1	Front fork assy
59	184.271.13	2	Screw
60	184.145.13	2	Nut

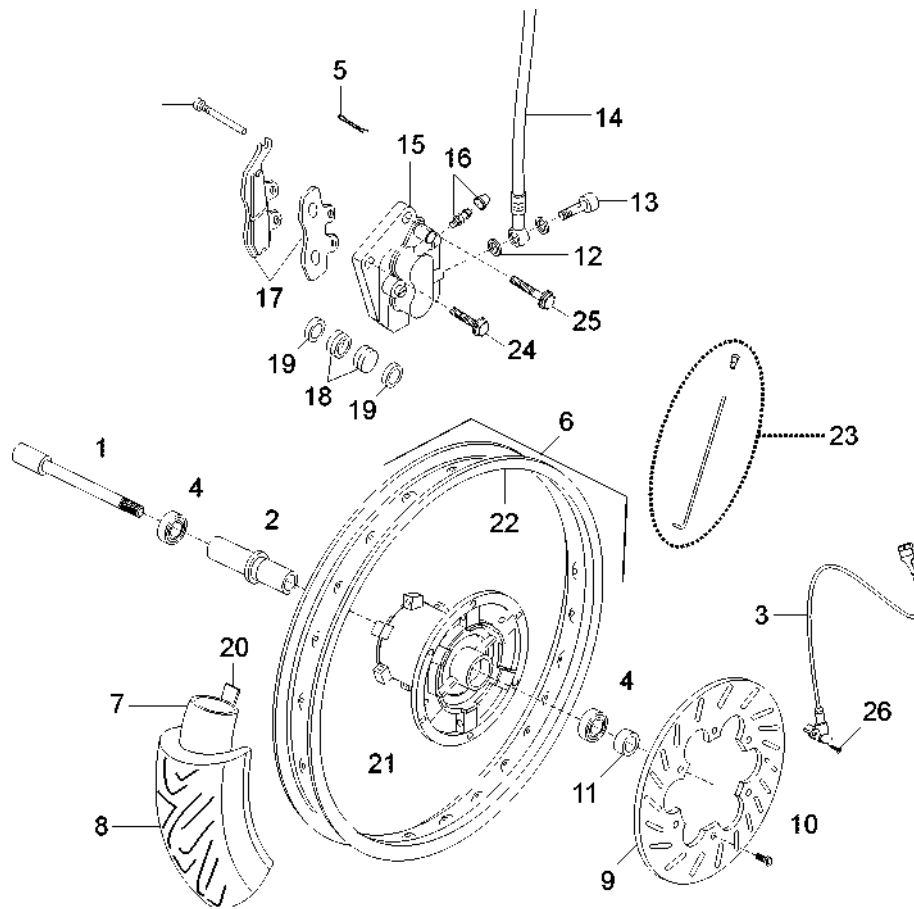

Nr.	Codice	Q.tà	Descrizione
1	100.020.13	1	Perno ruota anteriore
2	119.558.00	1	Distanziale cuscinetti
3	178.178.00	1	Rinvio contakm elettronico Hall
4	119.554.00	2	Cuscinetto ruota
5	119.565.00	2	Copiglia
6	111.037.00	1	Ruota anteriore
7	054.044.00	1	Camera d' aria 3.00 - 17
8	053.009.00	1	Copertura 100 / 80 - 17
9	119.552.00	1	Disco freno anteriore
10	184.128.13	6	Vite disco freno
11	150.303.13	1	Distanziale
12	190.006.00	2	Rasamenti
13	150.024.14	1	Vite trasmissione idraulica
14	033.055.00	1	Trasmissione idraulica anteriore
15	031.031.03	1	Pinza freno anteriore
16	119.564.00	1	Valvola di sfiato
17	119.557.00	1	Cp. pastiglie freno anteriori
18	119.571.00	2	Pistoncini
19	119.573.00	2	Anelli di tenuta
20	070.018.00	1	Cordone salvacamera 17
21	114.015.00	1	Mozzo anteriore
22	117.036.00	1	Cerchio 2.50 x 17 - 36 fori
23	118.061.00	1	Kit raggi + nipples anteriori
24	184.123.13	1	Bullone
25	184.031.13	1	Bullone
26	184.256.00	1	Vite

Nr.	Code	Q.ty	Description
1	100.020.13	1	Front wheel spindle
2	119.558.00	1	Bearing spacer
3	178.178.00	1	Speedo drive, Hall
4	119.554.00	2	Wheel bearing
5	119.565.00	2	Split pin
6	111.037.00	1	Front wheel
7	054.044.00	1	Air tube 3.00 - 17
8	053.009.00	1	Tyre 100 / 80 - 17
9	119.552.00	1	Front brake disc
10	184.128.13	6	Front brake fixing screw
11	150.303.13	1	Spacer
12	190.006.00	2	Copper banjo washer
13	150.024.14	1	Brake hose bolt
14	033.055.00	1	Front hydraulic brake hose
15	031.031.03	1	Front brake caliper
16	119.564.00	1	Bleeding overhaul set
17	119.557.00	1	Front brake pad set
18	119.571.00	2	Brake pistons
19	119.573.00	2	Seal ring caliper
20	070.018.00	1	Band rim
21	114.015.00	1	Front hub
22	117.036.00	1	Front wheel rim
23	118.061.00	1	Front wheel spoke + nipples kit
24	184.123.13	1	Bolt
25	184.125.13	1	Bolt
26	184.256.00	1	Screw

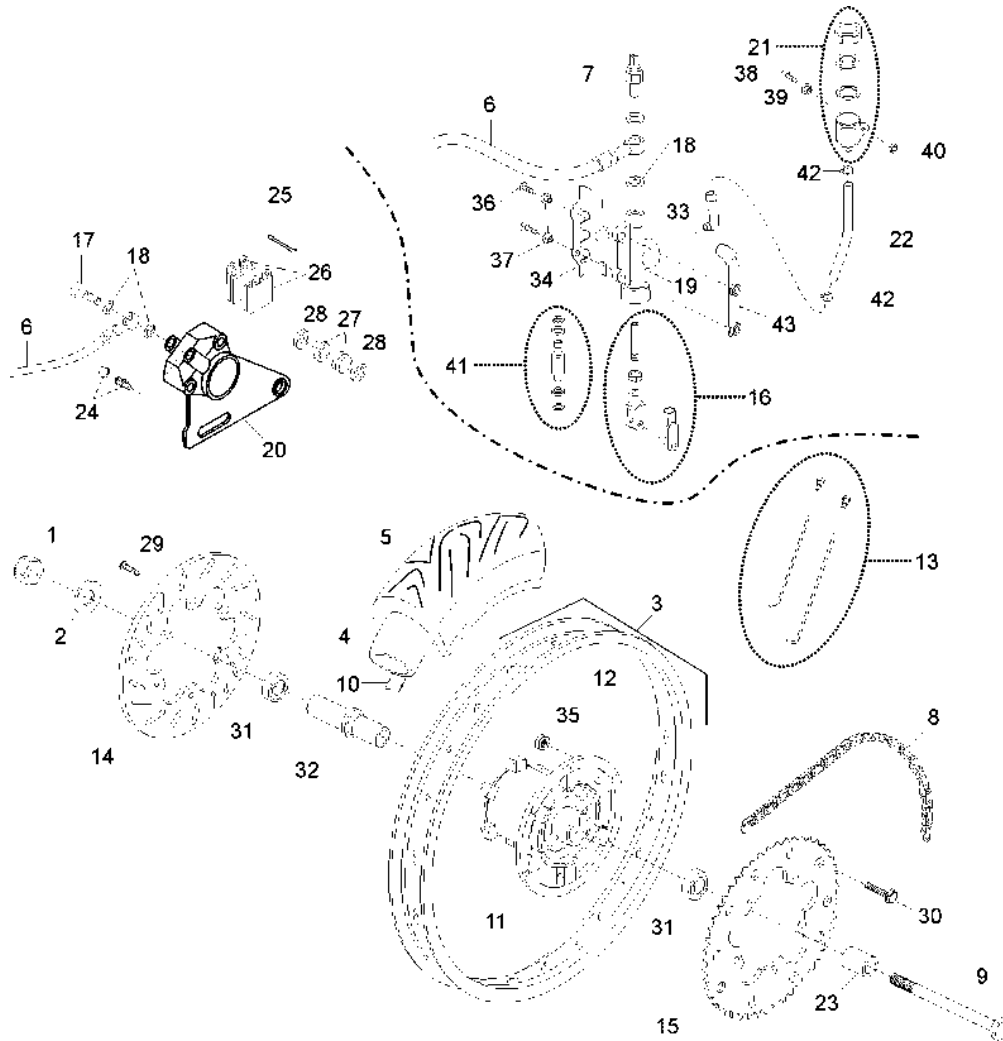

Nr.	Codice	Q.tà	Descrizione
1	185.010.00	1	Dado ruota posteriore
2	119.224.00	1	Rondella
3	112.050.00	1	Ruota posteriore
4	054.045.00	1	Camera d' aria 4.00 - 17
5	053.010.00	1	Copertura 130 / 70 - 17
6	033.054.00	1	Trasmissione idraulica posteriore
7	021.025.00	1	Interruttore stop idraulico
8	049.073.00	1	Catena 1/2 x 1/4 - 126 maglie
9	100.021.13	1	Perno ruota posteriore
10	070.018.00	1	Cordone salvacamera 17
11	114.014.00	1	Mozzo posteriore
12	117.037.00	1	Cerchio 3.00 x 17 - 36 fori
13	118.062.00	1	Kit raggi + nipples posteriori
14	119.551.00	1	Disco freno posteriore
15	122.016.00	1	Corona Z = 48
16	119.553.00	1	Asta leva freno + forcella
17	150.024.14	1	Vite trasmissione idraulica
18	190.006.00	4	Rasamento
19	030.029.03	1	Pompa freno posteriore
20	031.030.03	1	Pinza freno posteriore
21	069.022.00	1	Serbatoio olio freni
22	180.063.00	1	Tube pompa freno - serbatoio olio
23	150.312.13	1	Distanziale pacco ruota
24	119.564.00	1	Valvola di sfiato
25	119.567.00	2	Copiglia

Nr.	Code	Q.ty	Description
1	185.010.00	1	Rear wheel nut
2	119.224.00	1	Washer
3	112.050.00	1	Rear wheel
4	054.045.00	1	Air tube 4.00 - 17
5	053.010.00	1	Tyre 130 / 70 - 17
6	033.054.00	1	Rear hydraulic brake hose
7	021.025.00	1	Hydraulic stop switch
8	049.073.00	1	Chain
9	100.021.13	1	Rear wheel axle
10	070.018.00	1	Band rim
11	114.014.00	1	Rear hub
12	117.037.00	1	Rear wheel rim
13	118.062.00	1	Rear wheel spoke + nipples kit
14	119.551.00	1	Rear brake disc
15	122.016.00	1	Rear sprocket
16	119.553.00	1	Rear brake rod with fork
17	150.024.14	1	Brake hose bolt
18	190.006.00	4	Copper banjo bolt
19	030.029.03	1	Rear master cylinder
20	031.030.03	1	Rear brake caliper
21	069.022.00	1	Brake oil tank
22	180.063.00	1	Brake hose
23	150.312.13	1	Spacer
24	119.564.00	1	Bleeding overhaul set
25	119.567.00	2	Split pin

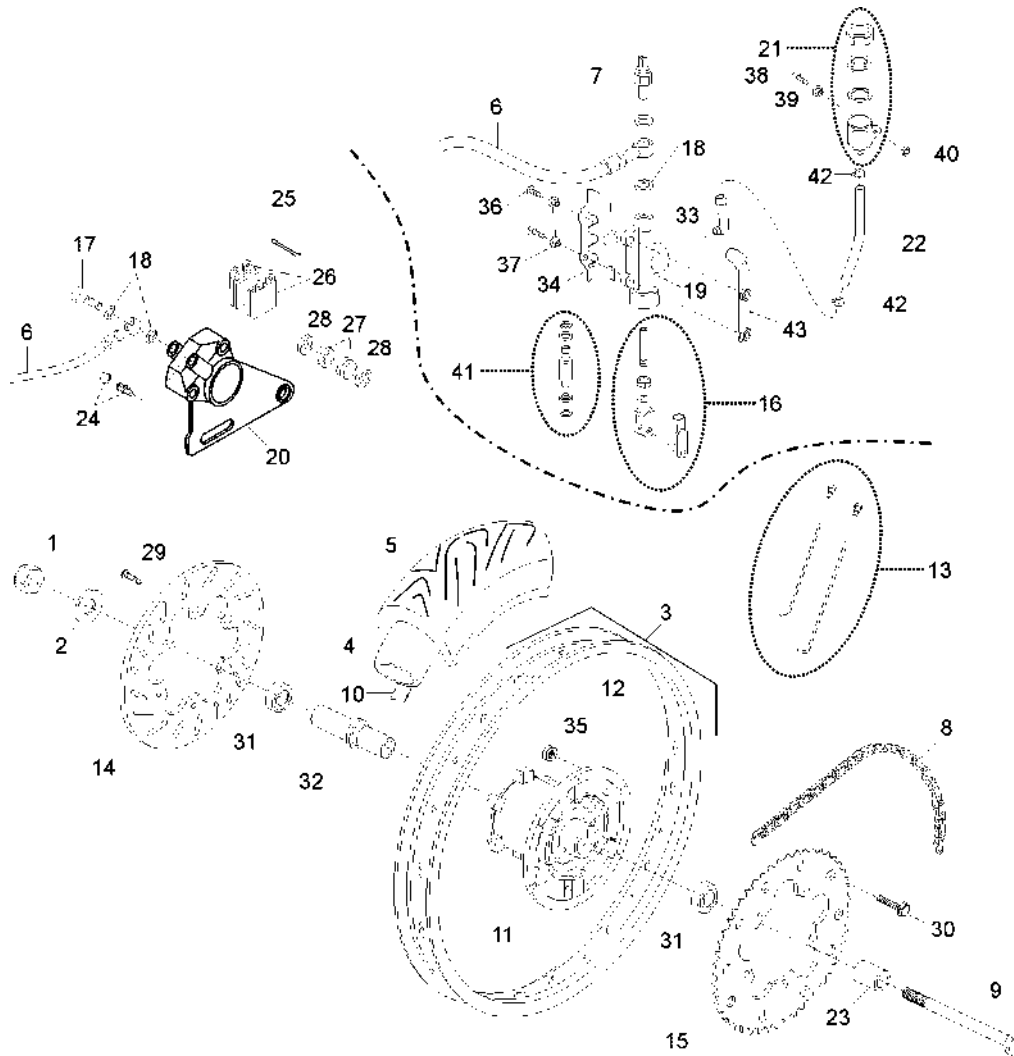

Nr.	Codice	Q.tà	Descrizione
26	119.556.00	1	Cp. pastiglie freno posteriori
27	119.560.00	2	Pistoncini
28	119.566.00	2	Anelli di tenuta
29	184.122.13	3	Vite disco freno
30	184.031.13	6	Vite fissaggio corona - mozzo
31	119.554.00	2	Cuscinetto ruota
32	119.559.00	1	Distanziale cuscinetti
33	094.037.00	1	Raccordo pompa freno
34	071.541.03	1	Carter copripompa freno posteriore
35	184.147.13	6	Dado
36	184.255.15	2	Vite
37	150.148.14	2	Boccola
38	184.254.15	1	Vite
39	184.051.13	1	Rondella
40	184.078.13	1	Dado
41	121.165.00	1	Serie anelli tenuta pompa freno
42	167.018.13	2	Fascetta
43	191.085.13	1	Staffa fissaggio pompa freno

Nr.	Code	Q.ty	Description
26	119.556.00	1	Rear brake pad set
27	119.560.00	2	Brake pistons
28	119.566.00	2	Seal ring caliper
29	184.122.13	3	Rear brake fixing screw
30	184.031.13	6	Rear hub fixing screw
31	119.554.00	2	Wheel bearing
32	119.559.00	1	Bearing spacer
33	094.037.00	1	Master cylinder joint
34	071.541.03	1	Rear master cylinder protection
35	184.147.13	6	Nut
36	184.255.15	2	Screw
37	150.148.14	2	Collar
38	184.254.15	1	Screw
39	184.051.13	1	Washer
40	184.078.13	1	Nut
41	121.165.00	1	Seal ring brake pump set
42	167.018.13	2	Clamp
43	191.085.13	1	Rear master cylinder bracket

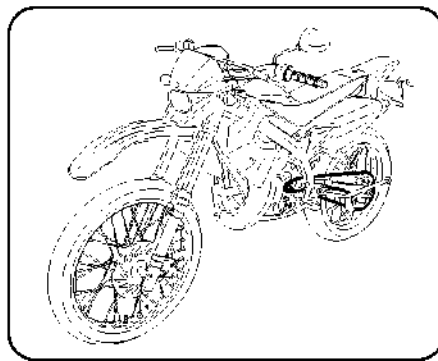
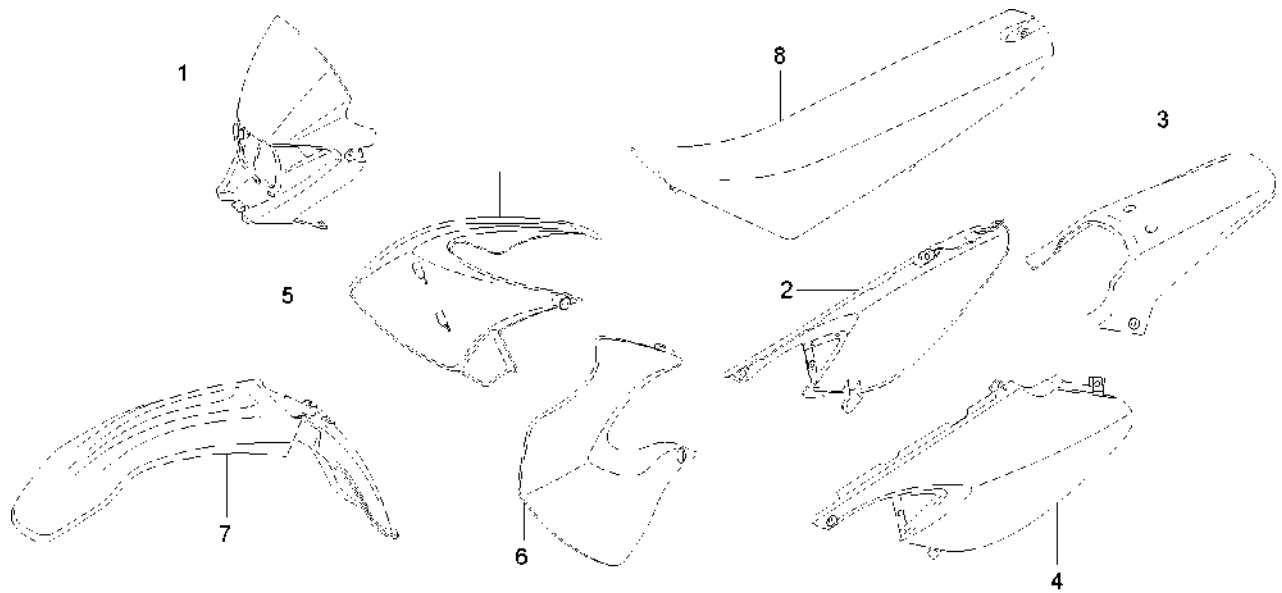
**Colori moto
Colour table**

TABELLA COLORI - COLOUR CODES
Colori - Colours

N° Nr.	Codice Code	08 ArgentoMotard Motard Silver	03 Nero Motard Motard Black					
1	058.049.	77	73					
2	060.114.	77	73					
3	056.075.	77	73					
4	060.115.	77	73					
5	062.072.	77	73					
6	062.073.	77	73					
7	055.064.	77	73					
8	106.098.	54	54					
--	181.370.	50	51					

Motore AM 6

AM 6 engine parts

Nr.	Codice	Q.tà	Descrizione
15	715.106.00	1	Carburatore DELL'ORTO PHBN 16 - NS / R
19	771.178.00	1	Cilindro completo + pistone Ø 40.3 standard
62	771.177.00	1	Pistone completo Ø 40.3 standard
77	777.022.00	1	Testa con resche
82	782.022.00	1	Volano magnete
99	709.008.00	1	Desmodromico
111	711.011.00	1	Candela
212	721.084.00	1	Coperchio frizione completo
213	721.085.00	1	Coperchio pompa olio
214	721.086.00	1	Coperchio volano
332	733.010.00	1	Forchetta selettore con perni
333	733.011.00	1	Forchetta comando con perno
334	733.012.00	1	Forchetta comando con perno
335	733.013.00	1	Forchetta comando con perno
381	771.179.00	1	Imbiellaggio + gabbia
382	771.180.00	1	Biella completa
435	743.021.00	1	Leva frizione completa
471	747.002.00	1	Molla richiamo leva M.M.
582	758.020.00	1	Pignone rinvio Z = 11
606	760.063.00	1	Collettore aspirazione
641	799.118.00	1	Kit pompa olio completa
657	765.010.00	1	Ponte registro filo pompa olio
658	765.011.00	1	Ponte cavo frizione
681	771.181.00	1	Serie segmenti Ø 40
701	770.027.00	1	Coppia carter
911	701.062.00	1	Albero primario
912	701.063.00	1	Albero messa in moto
913	081.013.00	1	Leva messa in moto
914	701.064.00	1	Albero secondario
915	701.065.00	1	Albero selettore con piastrina
916	082.010.00	1	Leva cambio
917	701.066.00	1	Contralbero
2430	724.076.00	1	Gommino registro filo pompa olio
2467	724.040.00	1	Manicotto entrata acqua
2472	760.066.00	1	Inserto valvola a lamelle
2478	724.077.00	1	Gommino passatubi pompa olio
2492	724.033.00	1	Tappo alimentazione olio
2607	715.107.00	1	Tubetto deviatore
2655	726.049.00	1	Piastrina passatubo
3511	735.021.00	1	Spingidisco frizione
3540	753.018.00	3	Disco frizione condotto
3551	735.022.00	4	Disco frizione conduttore
4001	771.108.00	1	Coppia frizione Z = 20 / 71
4017	740.107.00	1	Tamburo frizione

Nr.	Code	Q.ty	Description
15	715.106.00	1	Carburettor DELL'ORTO PHBN 16 - NS / R 3145
19	771.178.00	1	Cylinder assy Ø 40.3 standard
62	771.177.00	1	Piston assy Ø 40.3 standard
77	777.022.00	1	Cylinder head assy
82	782.022.00	1	Magneto flywheel
99	709.008.00	1	Shift cam assy
111	711.011.00	1	Spark plug
212	721.084.00	1	Clutch cover assy
213	721.085.00	1	Oli pump cover
214	721.086.00	1	Magneto flywheel cover
332	733.010.00	1	Shift fork
333	733.011.00	1	Shift fork 1° - 3°
334	733.012.00	1	Shift fork 2° - 4°
335	733.013.00	1	Shift fork 5° - 6°
381	771.179.00	1	Cranckshaft
382	771.180.00	1	Connecting rod
435	743.021.00	1	Clutch lever assy
471	747.002.00	1	Hub returning lever
582	758.020.00	1	Sprocket Z = 11
606	760.063.00	1	Intake manifold
641	799.118.00	1	Oil pump kit assy
657	765.010.00	1	Oil cable holder
658	765.011.00	1	Clutch cable holder
681	771.181.00	1	Piston ring assy Ø 40 standard
701	770.027.00	1	Cranckase set
911	701.062.00	1	Main shaft
912	701.063.00	1	Kick starter shaft
914	701.064.00	1	Counter shaft
915	701.065.00	1	Gear selector shaft
917	701.066.00	1	Balancer shaft
2430	724.076.00	1	Oil pump rubber
2467	724.040.00	1	Water manifold
2472	760.066.00	1	Reed valve insert
2478	724.077.00	1	Oil pump rubber
2492	724.033.00	1	Oil plug
2607	715.107.00	1	Pipe
2655	726.049.00	1	Pipe plate
3511	735.021.00	1	Clutch pressure disc
3540	753.018.00	3	Clutch plate driven
3551	735.022.00	4	Clutch plate drive
4001	771.108.00	1	Gear set Z = 20 / 71
4017	740.107.00	1	Clutch drum

Motore AM 6

AM 6 engine parts

Nr.	Codice	Q.tà	Descrizione
-----	--------	------	-------------

4022	740.162.00	1	Ingranaggio 2° velocità su primario
4023	740.163.00	1	Ingranaggio 3° - 4° velocità su primario
4025	740.164.00	1	Ingranaggio 5° velocità su primario
4026	740.165.00	1	Ingranaggio 6° velocità su primario
4031	740.166.00	1	Ingranaggio 1° velocità su secondario
4032	740.167.00	1	Ingranaggio 2° velocità su secondario
4033	740.168.00	1	Ingranaggio 3° velocità su secondario
4034	740.169.00	1	Ingranaggio 4° velocità su secondario
4035	740.170.00	1	Ingranaggio 5° velocità su secondario
4036	740.171.00	1	Ingranaggio 6° velocità su secondario
4040	740.111.00	1	Ingranaggio doppio intermedio
4045	740.172.00	1	Ingranaggio messa in moto
4048	740.113.00	1	Ingranaggio condotto pompa acqua
4049	740.039.00	1	Ingranaggio condotto pompa olio - acqua
4060	740.173.00	1	Coppia ingranaggi contralbero
4066	740.023.00	1	Ingranaggio scorrevole messa in moto
4620	746.036.00	4	Molla frizione
4625	746.006.00	1	Molla innesto scorrevole M.M.
4635	746.061.00	1	Molla sfera segnamarce
4650	746.013.00	1	Molla richiamo forchetta selettore
4655	746.014.00	1	Molla richiamo leva comando cambio
4660	746.038.00	1	Molla richiamo leva frizione
4665	746.019.00	1	Molla richiamo leva M.M
4680	746.030.00	1	Molla a disco reggispinta 17.3 x 27.7 x 0.35
5101	751.001.00	2	Astuccio a rullini DB 14 - 12
5106	751.038.00	1	Boccola guida molla selettore
5113	751.008.00	1	Gabbia KBK Ø 12 x 15 x 15
5146	751.005.00	1	Cuscinetto Ø 15 x 35 x 11 (6202)
5148	603.227.00	1	Cuscinetto Ø 17 x 40 x 12 (6203)
5156	751.087.00	1	Cuscinetto Ø 20 x 47 x 14 (6204)
5172	603.344.00	1	Cuscinetto Ø 17 x 40 x 12 (6203)
5178	751.040.00	2	Cuscinetto Ø 17 x 47 x 14
5181	751.030.00	1	Sfera 3 / 16
5182	751.037.00	1	Sfera Ø 9
5303	753.002.00	2	Anello di tenuta O.R. Ø 12.5 x 1.5
5310	753.166.00	1	Anello di tenuta O.R. Ø 25.07 x 2.62
5315	753.167.00	1	Anello di tenuta O.R. Ø 15.1 x 2.7
5318	753.048.00	1	Anello di tenuta O.R. Ø 11.8 x 2.4
5320	753.097.00	1	Guarnizione base cilindro
5327	753.098.00	1	Guarnizione coperchio frizione
5341	753.100.00	1	Guarnizione corpo pompa acqua
5357	753.028.00	1	Guarnizione vite arresto scorrevole
5358	753.058.00	1	Guarnizione vite livello olio
5359	753.029.00	1	Guarnizione vite scarico olio

Nr.	Code	Q.ty	Description
-----	------	------	-------------

4022	740.162.00	1	Gear 2 nd drive
4023	740.163.00	1	Gear 3 rd - 4 th drive
4025	740.164.00	1	Gear 5 th drive
4026	740.165.00	1	Gear 6 th drive
4031	740.166.00	1	Gear 1 st driven
4032	740.167.00	1	Gera 2 nd driven
4033	740.168.00	1	Gear 3 rd driven
4034	740.169.00	1	Gear 4 th driven
4035	740.170.00	1	Gear 5 th driven
4036	740.171.00	1	Gear 6 th driven
4040	740.111.00	1	Idle gear assy
4045	740.172.00	1	Starting gear
4048	740.113.00	1	Water pump gear
4049	740.039.00	1	Oil pump gear
4060	740.173.00	1	Balancer shaft gear set
4066	740.023.00	1	Starting sliding
4620	746.036.00	4	Clutch spring
4625	746.006.00	1	Starting sliding spring
4635	746.061.00	1	Gear spring
4650	746.013.00	1	Fork spring
4655	746.014.00	1	Gear lever spring
4660	746.038.00	1	Clutch lever spring
4665	746.019.00	1	Kick starter spring
4680	746.030.00	1	Spring
5101	751.001.00	2	Needle bearing DB 14 - 12
5106	751.038.00	1	Selector bush
5113	751.008.00	1	Roller bearing KBK Ø 12 x 15 x 15
5146	751.005.00	1	Bearing Ø 15 x 35 x 11 (6202)
5148	603.227.00	1	Bearing Ø 17 x 40 x 12 (6203)
5156	751.087.00	1	Bearing Ø 20 x 47 x 14 (6204)
5172	603.344.00	1	Bearing Ø 17 x 40 x 12 (6203)
5178	751.040.00	2	Bearing Ø 17 x 47 x 14
5181	751.030.00	1	Cage 3 / 16
5182	751.037.00	1	Cage Ø 9
5303	753.002.00	2	Oil seal O.R. Ø 12.5 x 1.5
5310	753.166.00	1	Oil seal O.R. Ø 25.07 x 2.62
5315	753.167.00	1	Oil seal O.R. Ø 15.1 x 2.7
5318	753.048.00	1	Oil seal O.R. Ø 11.8 x 2.4
5320	753.097.00	1	Base cylinder gasket
5327	753.098.00	1	Clutch cover gasket
5341	753.100.00	1	Water pump body gasket
5357	753.028.00	1	Gasket
5358	753.058.00	1	Oil level screw gasket
5359	753.029.00	1	Oil drain screw gasket

Motore AM 6
AM 6 engine parts

Nr.	Codice	Q.tà	Descrizione
5361	753.030.00	1	Guarnizione vite scarico acqua
5362	753.169.00	1	Guarnizione
5371	753.031.00	1	Paraolio Ø 12 x 22 x 7
5372	753.170.00	1	Paraolio Ø 15 x 24 x 5
5376	753.171.00	1	Paraolio B1B Ø 17 x 35 x 8
5395	753.172.00	1	Paraolio BADUO Ø 10 x 18 x 8
5398	753.102.00	1	Paraolio BAVI U3 24 x 35 x 7
5603	756.060.00	1	Perno pompa acqua con girante
5605	743.022.00	1	Asta frizione
5609	021.027.00	1	Bulbo temperatura acqua
5611	756.104.00	1	Busta porta sfera segnamarce
5612	756.080.00	1	Termostato
5615	756.015.00	2	Grano riferimento carter
5616	756.016.00	2	Grano riferimento coperchi
5636	756.064.00	1	Perno guida forchetta
5637	756.105.00	1	Perno guida forchetta
5645	756.035.00	1	Interruttore spia folle
5650	756.106.00	1	Perno pompa olio
5653	756.107.00	1	Perno
5661	756.024.00	2	Rullo per ingranaggio
5663	756.038.00	2	Rullo riferimento corpo pompa
5665	756.013.00	1	Asta spingidisco frizione completa
5670	756.055.00	1	Spinotto Ø 12 x 34.5
6013	760.064.00	1	Corpo pompa acqua
6015	760.065.00	1	Valvola lamelle completa
6050	094.023.00	1	Valvola aria AIS
9323	703.034.00	2	Anello fermo spinotto Ø 12
9351	703.035.00	3	Anello seeger per albero Ø 8
9352	703.036.00	2	Anello seeger per albero Ø 12
9355	703.037.00	2	Anello seeger per albero Ø 18
9356	703.038.00	1	Anello seeger per albero Ø 18
9362	703.039.00	3	Anello seeger per albero Ø 20
9363	703.040.00	2	Anello seeger per albero Ø 14
9365	703.041.00	3	Anello seeger per albero Ø 20
15270	715.056.00	1	Raccordo sfiato olio
24107	077.058.00	2	Tubo raccordo testa - carburatore
49005	749.180.00	1	Fascetta collettore aspirazione
49007	749.147.00	1	Fascetta tubo entrata olio
49009	749.285.00	1	Chiavetta ingranaggio contralbero
49010	749.170.00	1	Chiavetta pignone
49015	749.003.00	1	Chiavetta volano magnete
49022	749.220.00	4	Fascetta
49035	749.074.00	1	Dado M 7 x 5.5 - (CH = 12)
49037	749.209.00	4	Dado M 7 x 1 autobloccante cieco

Nr.	Code	Q.ty	Description
5361	753.030.00	1	Water hose gasket
5362	753.169.00	1	Neutral switch gasket
5371	753.031.00	1	Oil seal Ø 12 x 22 x 7
5372	753.170.00	1	Oil seal Ø 15 x 24 x 5
5376	753.171.00	1	Oli seal B1B Ø 17 x 35 x 8
5395	753.172.00	1	Oil seal BADUO Ø 10 x 18 x 8
5398	753.102.00	1	Oil seal BAVI U3 24 x 35 x 7
5603	756.060.00	1	Water pump impeller
5605	743.022.00	1	Clutch push rod
5609	021.027.00	1	Water temperature switch
5611	756.104.00	1	Gear cage housing
5612	756.080.00	1	Thermostat
5615	756.015.00	2	Crankcase pin
5616	756.016.00	2	Cover pin
5636	756.064.00	1	Fork pin
5637	756.105.00	1	Fork pin
5645	756.035.00	1	Neutral switch
5650	756.106.00	1	Oil pump pivot
5653	756.107.00	1	Pivot
5661	756.024.00	2	Gear pin
5663	756.038.00	2	Water pump body pin
5665	756.013.00	1	Clutch push rod
5670	756.055.00	1	Piston pin Ø 12 x 34.5
6013	760.064.00	1	Water pump body
6015	760.065.00	1	Reed valve assy
6050	094.023.00	1	Airvalve AIS
9323	703.034.00	2	Piston pin circlip Ø 12
9351	703.035.00	3	Seeger shaft Ø 8
9352	703.036.00	2	Seeger shaft Ø 12
9355	703.037.00	2	Seeger shaft Ø 18
9356	703.038.00	1	Seeger shaft Ø 18
9362	703.039.00	3	Seeger shaft Ø 20
9363	703.040.00	2	Seeger shaft Ø 14
9365	703.041.00	3	Seeger shaft Ø 20
15270	715.056.00	1	Oil drain joint
24107	077.058.00	2	Head - carburettor hose joint
49005	749.180.00	1	Intake manifold clamp
49007	749.147.00	1	Clamp
49009	749.285.00	1	Balancer shaft key
49010	749.170.00	1	Sprocket key
49015	749.003.00	1	Woodruff key
49022	749.220.00	4	Clamp
49035	749.074.00	1	Nut M 7 x 5.5 - (CH = 12)
49037	749.209.00	4	Nut M 7 x 1

Motore AM 6
AM 6 engine parts

Nr.	Codice	Q.tà	Descrizione
49040	749.158.00	1	Dado M 10 x 1.25 - (CH = 15)
49041	749.052.00	1	Dado M 12 x 1.25 - (CH = 17) - H = 7
49042	749.009.00	1	Dado M 14 x 1.25 - (CH = 19) - H = 6
49049	749.111.00	1	Dado M 12 x 1 - (CH = 19) - H = 5
49056	749.272.00	1	Dado M 12 x 1.25 - (CH = 17) - H = 11
49068	749.077.00	1	Distanziale forchetta
49070	749.286.00	1	Distanziale cuscinetto paraolio frizione
49074	749.115.00	1	Distanziale inferiore tamburo frizione
49084	749.078.00	4	Prigioniero M 7 x 115
49095	749.287.00	4	Rondella bisellata Ø 7.4 x 14 x 1.6
49099	749.288.00	1	Dado M 5 x 0.75
49101	749.079.00	1	Rondella dentellata Ø 7
49120	749.054.00	2	Rondella rasamento Ø 10 x 16 x 0.6
49122	749.273.00	1	Rondella Ø 12 x 17 x 0.6
49124	749.025.00	2	Rondella Ø 12.3 x 22
49131	749.274.00	1	Rondella Ø 16 x 25 x 0.4
49132	749.275.00	1	Rondella Ø 17.2 x 30 x 0.8
49135	749.276.00	1	Rondella Ø 20.45 x 28 x 0.4
49139	749.277.00	1	Rondella Ø 14.5 x 27 x 0.4
49151	749.161.00	3	Rondella Ø 8.4 x 16 x 0.6
49155	749.120.00	3	Rondella Ø 8.2 x 15 x 1
49175	749.061.00	1	Rondella Ø 12.75 x 28 x 1.5
49191	749.127.00	4	Rondella Ø 5 x 15 x 2
49192	749.128.00	1	Rondella Ø 12
49193	749.129.00	1	Rondella Ø 14 x 26 x 0.5
49200	749.063.00	1	Vite registro frizione
49226	749.278.00	3	Vite M 4 x 10 con flangia
49227	749.035.00	2	Vite M 6 x 7
49228	749.138.00	4	Vite M 5 x 20
49230	749.088.00	2	Vite M 4 x 10
49236	749.141.00	2	Vite M 5 x 16
49238	749.065.00	5	Vite M 5 x 20
49244	749.279.00	2	Vite M 6 x 22
49245	749.068.00	2	Vite M 6 x 25
49246	749.038.00	7	Vite M 6 x 30
49248	749.280.00	13	Vite M 6 x 40
49251	749.281.00	1	Vite M 6 x 55
49255	749.176.00	1	Vite M 6 x 12
49281	749.069.00	1	Vite M 8 x 10 - (CH = 13) scarico olio
49290	749.070.00	1	Vite M 12 x 1.25 arresto scorrevole M.M.
49292	749.282.00	2	Vite M 6 x 20
49405	749.255.00	1	Rondella Ø 6 x 11 x 1.2
49528	749.283.00	1	Vite tendifilo
49840	749.284.00	2	Vite M 5 x 35

Nr.	Code	Q.ty	Description
49040	749.158.00	1	Nut M 10 x 1.25 - (CH = 15)
49041	749.052.00	1	Nut M 12 x 1.25 - (CH = 17) - H = 7
49042	749.009.00	1	Nut M 14 x 1.25 - (CH = 19) - H = 6
49049	749.111.00	1	Nut M 12 x 1 - (CH = 19) - H = 5
49056	749.272.00	1	Nut M 12 x 1.25 - (CH = 17) - H = 11
49068	749.077.00	1	Fork spacer
49070	749.286.00	1	Bearing spacer
49074	749.115.00	1	Lower spacer
49084	749.078.00	4	Stud bolt M 7 x 115
49095	749.287.00	4	Washer Ø 7.4 x 14 x 1.6
49099	749.288.00	1	Nut M 5 x 0.75
49101	749.079.00	1	Washer Ø 7
49120	749.054.00	2	Washer Ø 10 x 16 x 0.6
49122	749.273.00	1	Washer Ø 12 x 17 x 0.6
49124	749.025.00	2	Washer Ø 12.3 x 22
49131	749.274.00	1	Washer Ø 16 x 25 x 0.4
49132	749.275.00	1	Washer Ø 17.2 x 30 x 0.8
49135	749.276.00	1	Washer Ø 20.45 x 28 x 0.4
49139	749.277.00	1	Washer Ø 14.5 x 27 x 0.4
49151	749.161.00	3	Washer Ø 8.4 x 16 x 0.6
49155	749.120.00	3	Washer Ø 8.2 x 15 x 1
49175	749.061.00	1	Washer Ø 12.75 x 28 x 1.5
49191	749.127.00	4	Washer Ø 5 x 15 x 2
49192	749.128.00	1	Washer Ø 12
49193	749.129.00	1	Washer Ø 14 x 26 x 0.5
49200	749.063.00	1	Clutch adjusting screw
49226	749.278.00	3	Screw M 4 x 10
49227	749.035.00	2	Screw M 6 x 7
49228	749.138.00	4	Screw M 5 x 20
49230	749.088.00	2	Screw M 4 x 10
49236	749.141.00	2	Screw M 5 x 16
49238	749.065.00	5	Screw M 5 x 20
49244	749.279.00	2	Screw M 6 x 22
49245	749.068.00	2	Screw M 6 x 25
49246	749.038.00	7	Screw M 6 x 30
49248	749.280.00	13	Screw M 6 x 40
49251	749.281.00	1	Screw M 6 x 55
49255	749.176.00	1	Screw M 6 x 12
49281	749.069.00	1	Screw M 8 x 10 - (CH = 13)
49290	749.070.00	1	Screw M 12 x 1.25
49292	749.282.00	2	Screw M 6 x 20
49405	749.255.00	1	Washer Ø 6 x 11 x 1.2
49528	749.283.00	1	Screw
49840	749.284.00	2	Screw M 5 x 35

XSM 50 SUPERMOTARD Kat Euro 2

Motore AM 6

AM 6 engine parts

Nr.	Codice	Q.tà	Descrizione
-----	--------	------	-------------

53309	753.174.00	1	Guarnizione testa esterna
53310	753.175.00	1	Guarnizione testa interna
53508	753.173.00	1	Paraolio BASL Ø 20 x 35 x 7
--	701.067.00	1	Albero primario completo
--	701.068.00	1	Albero secondario completo
--	701.069.00	1	Albero selettore completo
--	721.087.00	1	Coperchio frizione completo (Bollino Oro)
--	740.174.00	1	Cambio completo 6 velocità
--	799.116.00	1	Serie guarnizioni AM 6
--	771.110.00	1	Serie paraolio AM 6
--	771.176.00	1	Pistone completo Ø 40.3 - 1° maggiorazione
--	771.175.00	1	Serie segmenti Ø 40.3 - 1° maggiorazione
--	142.124.03	1	Motore completo (174.123) Euro 2

Nr.	Code	Q.ty	Description
-----	------	------	-------------

53309	753.174.00	1	External head gasket
53310	753.175.00	1	Internal head gasket
53508	753.173.00	1	Oil seal BASL Ø 20 x 35 x 7
--	701.067.00	1	Main shaft assy
--	701.068.00	1	Counter shaft assy
--	701.069.00	1	Gear selector shaft assy
--	721.087.00	1	Clutch cover assy (gold mark)
--	740.174.00	1	Gear assy 6 speed
--	799.116.00	1	Gasket set AM 6
--	771.110.00	1	Oil seal set AM 6
--	771.176.00	1	Piston assy Ø 40.3 - 1° oversized
--	771.175.00	1	Piston ring assy Ø 40.3 - 1° oversized
--	142.124.03	1	Engine assy (174.123) Euro 2

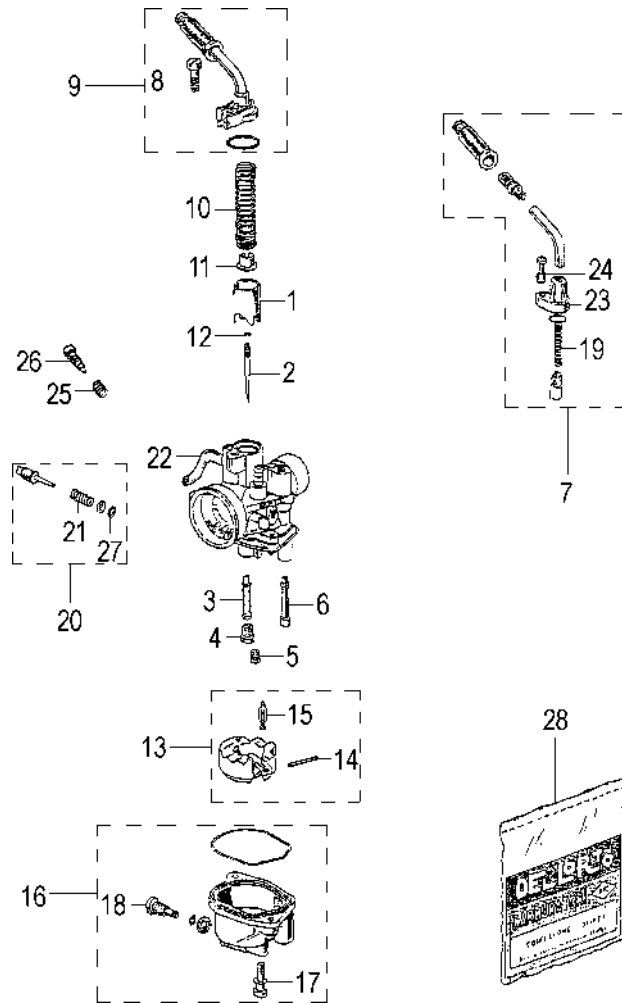
**Carburatore
Carburettor**

Nr.	Codice	Q.tà	Descrizione
01	623.266.00	1	Valvola gas completa Ø 40
02	623.265.00	1	Spillo conico 13 / 2A
03	623.264.00	1	Polverizzatore FQ 210
04	623.256.00	1	Getto massimo Ø 82
05	623.255.00	1	Getto minimo Ø 34
06	623.267.00	1	Getto avviamento Ø 45
07	623.268.00	1	Kit starter avviamento
08	623.263.00	1	Vite coperchio valvola gas
09	623.262.00	1	Coperchio valvola gas
10	623.259.00	1	Molla richiamo valvola gas
11	623.258.00	1	Fermo spillo conico
12	623.257.00	1	Seeger spillo conico
13	623.277.00	1	Galleggiante completo
14	623.278.00	1	Perno galleggiante
15	623.279.00	1	Spillo benzina
16	623.260.00	1	Vaschetta completa
17	623.254.00	2	Vite fissaggio vaschetta
18	623.261.00	1	Vite spurgo vaschetta
19	623.269.00	1	Molla starter
20	623.275.00	1	Kit vite regolazione valvola gas
21	623.276.00	1	Molla vite regolaz. valvola gas
22	623.280.00	1	Tubo aria vaschetta
23	623.270.00	1	Coperchio starter
24	623.271.00	1	Vite coperchio starter
25	623.272.00	1	Molla vite regolaz. aria minimo
26	623.273.00	1	Vite regolazione aria minimo
27	623.274.00	1	Rondella vite valvola gas
28	623.281.00	1	Busta guarnizioni
--	715.106.00	1	Carburatore completo Dell'Orto PHBN 16 - NS / R 3145

Nr.	Code	Q.ty	Description
01	623.266.00	1	Throttle valve assy Ø 40
02	623.265.00	1	Needle 13 / 2A
03	623.264.00	1	Spray nozzle FQ 210
04	623.256.00	1	Max jet Ø 82
05	623.255.00	1	Idle jet Ø 34
06	623.267.00	1	Starter jet Ø 45
07	623.268.00	1	Starter kit
08	623.263.00	1	Carburettor panel screw
09	623.262.00	1	Carburettor panel
10	623.259.00	1	Throttle valve spring
11	623.258.00	1	Needle ring
12	623.257.00	1	Needle seeger
13	623.277.00	1	Float assy
14	623.278.00	1	Float pivot
15	623.279.00	1	Lower needle
16	623.260.00	1	Float chamber assy
17	623.254.00	2	Float chamber fixing screw
18	623.261.00	1	Float chamber drain screw
19	623.269.00	1	Starter valve spring
20	623.275.00	1	Throttle valve adj. screw kit
21	623.276.00	1	Throttle valve spring screw
22	623.280.00	1	Float chamber pipe
23	623.270.00	1	Starter valve cover
24	623.271.00	1	Starter valve spring screw
25	623.272.00	1	Idle screw spring
26	623.273.00	1	Idle adj. screw
27	623.274.00	1	Throttle valve screw washer
28	623.281.00	1	Gasket set
--	715.106.00	1	Carburettor assy Dell'Orto PHBN 16 - NS / R 3145