

Figurato rubinetti benzina

28.0001 Ø 10x1 - codulo Ø 6
senza riserva - in zama

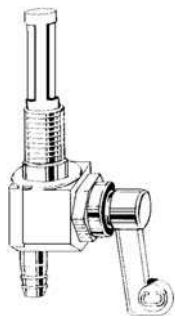

**Ciclomotori Motom • Benelli • Sachs
Malanca • Motori agricoli
Volpi & Bottoli • Minarelli • Beta**

28.0033 con riserva - con scatto - con leva
28.00331 con riserva - con scatto - senza leva
Ø 16x1 - codulo Ø 8

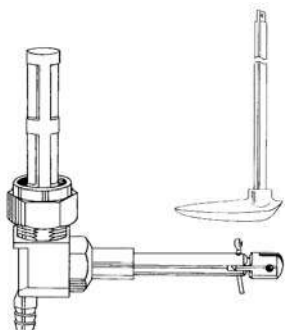

Innocenti

28.0041 Ø 10x1 - codulo Ø 9
senza riserva - a vite

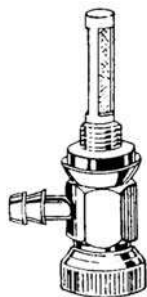

Benassi motori Agricoli
*permette un'alimentazione di carburante
di circa 30 litri/ora*

28.0058 Ø 12x1 - codulo Ø 6
con riserva - asta mm. 55

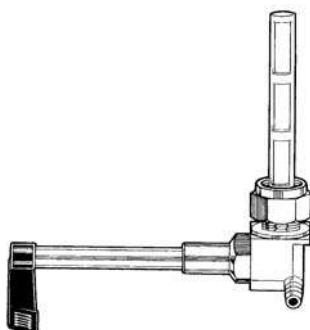

Piaggio

28.0022 Ø 12x1,5 - codulo Ø 6
con riserva - con scatto

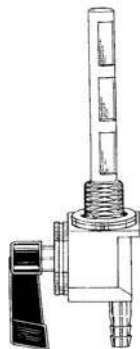

Ciclomotori e moto varie

28.00381 Ø 10x1 - codulo Ø 6 - con riserva
in zama - economico

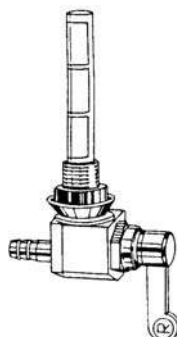

**Ciclomotori Peripoli • Cimatti • Demm
Negrini • Malaguti • Motori agricoli Sep**

28.0050 con riserva - con scatto - con leva
28.00501 con riserva - con scatto - senza leva
Ø 16x1 - codulo Ø 8

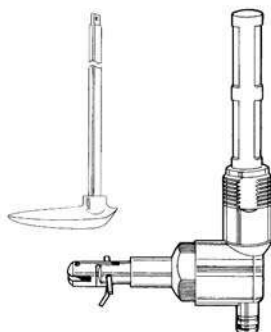

Innocenti

28.00251 Ø 10x1 - codulo Ø 6 - con riserva
in zama - economico

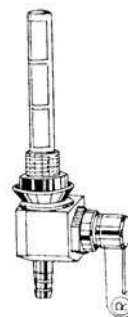

**Ciclomotori Benelli • Cimatti
Malaguti • Rizzato**

28.0040 Ø 10x1 - codulo Ø 6,5
senza riserva - a vite

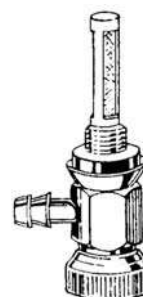

Minarelli motori agricoli
*permette un'alimentazione di carburante
di circa 30 litri/ora*

28.0052 Ø 16x1 - codulo Ø 8
con riserva - con scatto

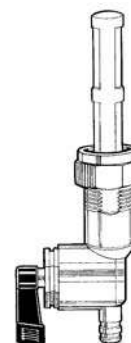

Innocenti

28.0059 Ø 12x1 - codulo Ø 6 - con riserva

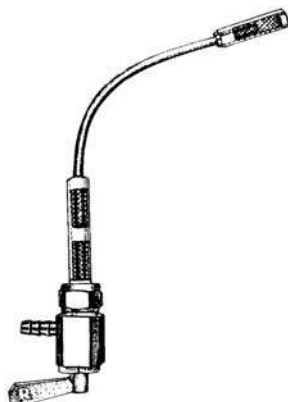

Piaggio

28.0063 Ø 10x1 - codulo Ø 6
con riserva - con scatto



Ciclomotori vari

28.0064 Ø 10x1 - codulo Ø 6
con riserva - con scatto

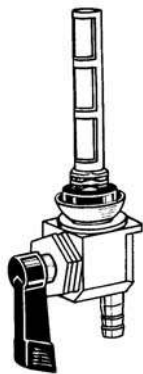

Peugeot • Ciclomotori vari

28.0066 Ø 12x1 - codulo Ø 6
con riserva - con scatto - in zama



DKW • Garelli • Zundapp

28.0067 Ø 12x1 - codulo Ø 8,5
senza riserva - a vite

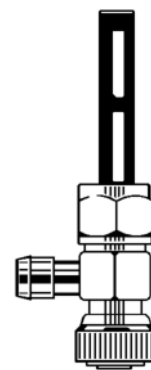

Piaggio

28.0070 Ø 12x1 - codulo Ø 8,5
senza riserva - a vite



Piaggio

28.0072 Ø 23x1,5 - codulo Ø 9
con riserva - asta lunga mm. 200

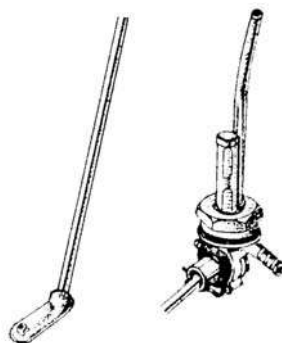

Piaggio

28.0073 Ø 24x1,5 - codulo Ø 9
con riserva - asta corta mm. 165

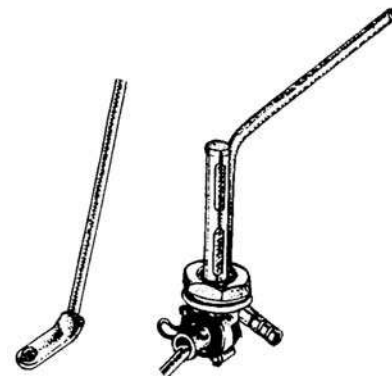

Piaggio

28.0074 sinistro con riserva
Ø 16x1 - codulo Ø 8

28.0109 destro con riserva Ø 16x1 - codulo Ø 8



Aprilia • Benelli • Beta • Guzzi

28.0076 Ø 16x1 - codulo Ø 6 - con riserva

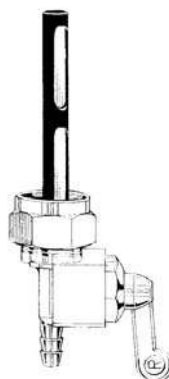

**Husqvarna • KTM • Tomos
Ciclomotori vari**

28.00761 Ø 16x1 - codulo Ø 6
con riserva (asta mm. 35)

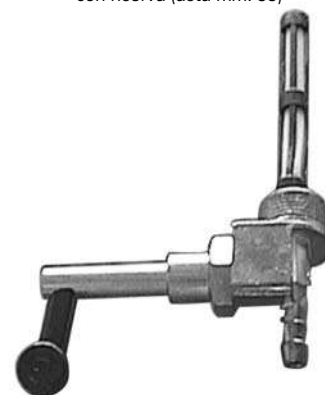

Husqvarna • KTM • Tomos

28.0077 Ø 12x1 - codulo Ø 6
con riserva - con scatto

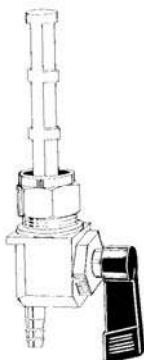

Gilera • Sachs • Ciclomotori vari

28.0078 Ø 12x1 - codulo Ø 6
con riserva - con scatto



Gilera • Garelli

28.0088 Ø 12x1 - codulo Ø 6 - con riserva



Benelli • Guzzi

28.0093 Ø 10x1 - codulo Ø 6
con riserva (asta mm. 27)

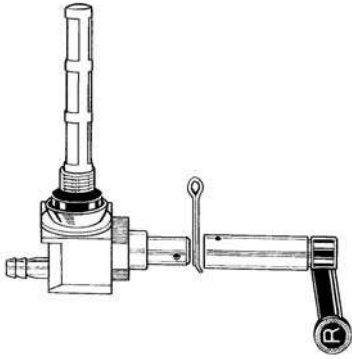

Rizzato

28.0101 Ø 16x1 - codulo Ø 8 - con riserva

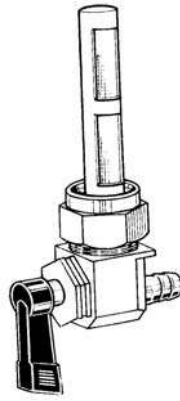

Fantic

28.0108 sinistro - con riserva
Ø 16x1 - codulo Ø 8
28.0110 destro - con riserva Ø 16x1
codulo Ø 8



Guzzi

28.0111 Ø 10x1 - codulo Ø 6 - con riserva



Beta • Peugeot

28.0112 Ø 10x1 - codulo Ø 6
senza riserva - a vite



Aspes

28.0120 Ø 12x1 - codulo Ø 6 - con riserva

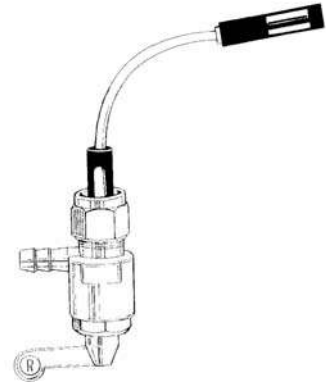

Puch

28.0124 Ø 10x1 - codulo Ø 7
con riserva - con vaschetta

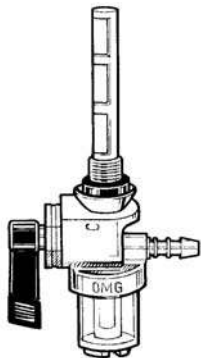

Ciclomotori vari

28.0132 Ø 12x1 - codulo Ø 6
con riserva (asta mm. 35)

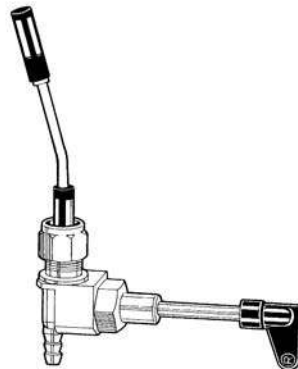

Benelli

28.0135 codulo Ø 8,5 - con riserva
attacco a flangia

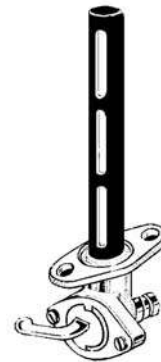

KTM

28.0137 Ø 16x1 - codulo Ø 6 - con riserva

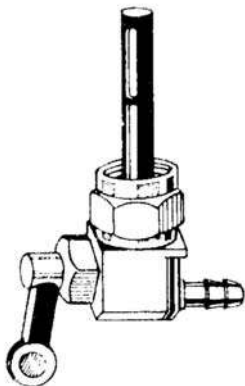

Honda

28.0138 Ø 12x1 - codulo Ø 6 - con riserva

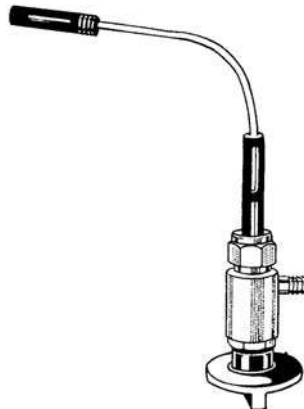

Gilera

28.0144 Ø 12x1 - codulo Ø 6 - con riserva
c/indicatore di posizione a scatto
(off - fuel - reserve)

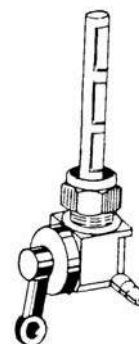

Piaggio

28.0226 sinistro - con riserva Ø 16x1
codulo Ø 8
28.0239 destro - con riserva Ø 16x1
codulo Ø 8



**Benelli • Ducati • Fantic
Gilera • Laverda • SWM**

28.0236 Ø 16x1 - codulo Ø 8 - destro
senza riserva



Guzzi

28.0238 Ø 24x1,5 - codulo Ø 9
con riserva - asta corta mm. 165

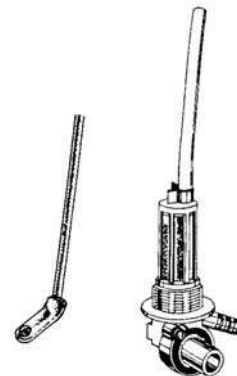

Piaggio

28.0241 Ø 16x1 - codulo Ø 8 - sinistro
con segnalatore elettrico riserva



Guzzi

28.0247 Ø 10x1 - codulo Ø 6 - con riserva

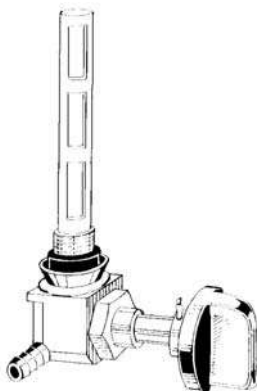

Malaguti

28.0267 codulo Ø 8 - con riserva
attacco a flangia



KTM

28.0512 codulo Ø 6 - attacco a depressione



**Aprilia • Benelli • Betamotor • Cagiva
Derbi • Gilera • Kymco • Italjet • Malaguti
MBK • Peugeot • Piaggio • Yamaha**

28.0514 codulo Ø 8 - attacco a flangia



Aprilia • Italjet • Malaguti • Rizzato

28.0521 Ø 11,5x1 - codulo Ø 6
s/leva - c/riserva

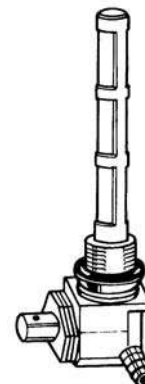

Peugeot

28.0523 codulo Ø 6 - attacco a depressione



Aprilia • Piaggio

28.0530 codulo Ø 6 - attacco a depressione
con segnalatore elettrico riserva
c/cavo 300 mm. - filtraggio 195
Micron livello riserva 55 mm.



Peugeot

28.0536 codulo Ø 6 - attacco a depressione



Gilera • MBK • Piaggio • Yamaha

28.0537 codulo Ø 6 - attacco a depressione



Gilera

28.0538 Ø 16x1,5 - codulo Ø 6



Honda

28.0539 codulo Ø 6 - attacco a depressione con riserva



Peugeot

28.0540 codulo Ø 6 - attacco a depressione con segnalatore elettrico riserva c/cavo 180 mm. - filtraggio 100 Micron livello riserva 51 mm.



Peugeot

28.0541 codulo Ø 6 - attacco a depressione con segnalatore elettrico riserva c/cavo 300 mm. - filtraggio 195 Micron livello riserva 70 mm.



Peugeot

28.0542 codulo Ø 6 - attacco a depressione



Peugeot

28.0544 Ø 12x1,5 - codulo Ø 8 - con riserva



Ducati

28.0604 Ø 10x1 - codulo Ø 6 - con riserva

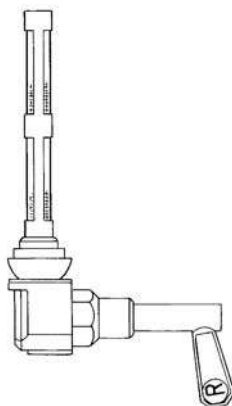

Peugeot

28.0608 codulo Ø 8,5 - attacco a depressione - senza riserva - a vite



Piaggio