



Ravaglioli

COMPANY WITH QUALITY MANAGEMENT
SYSTEM CERTIFIED BY DNV
= ISO 9001:2008 =

PONTI 4 COLONNE CON SOLLEVATORE INTEGRATO 

4-POST LIFTS WITH WHEEL FREE LIFT 

4-SÄULEN-HEBEBÜHNEN MIT RADFREIHEBER 

PONTS 4 COLONNES AVEC LEVAGE AUXILIAIRE 

4 COLUMNS CON DOBLE ELEVACIÓN 

RAV
4505 OFSI
4506 OFSI
4507 OFSI
4508 OFSI
OPEN
FRONT

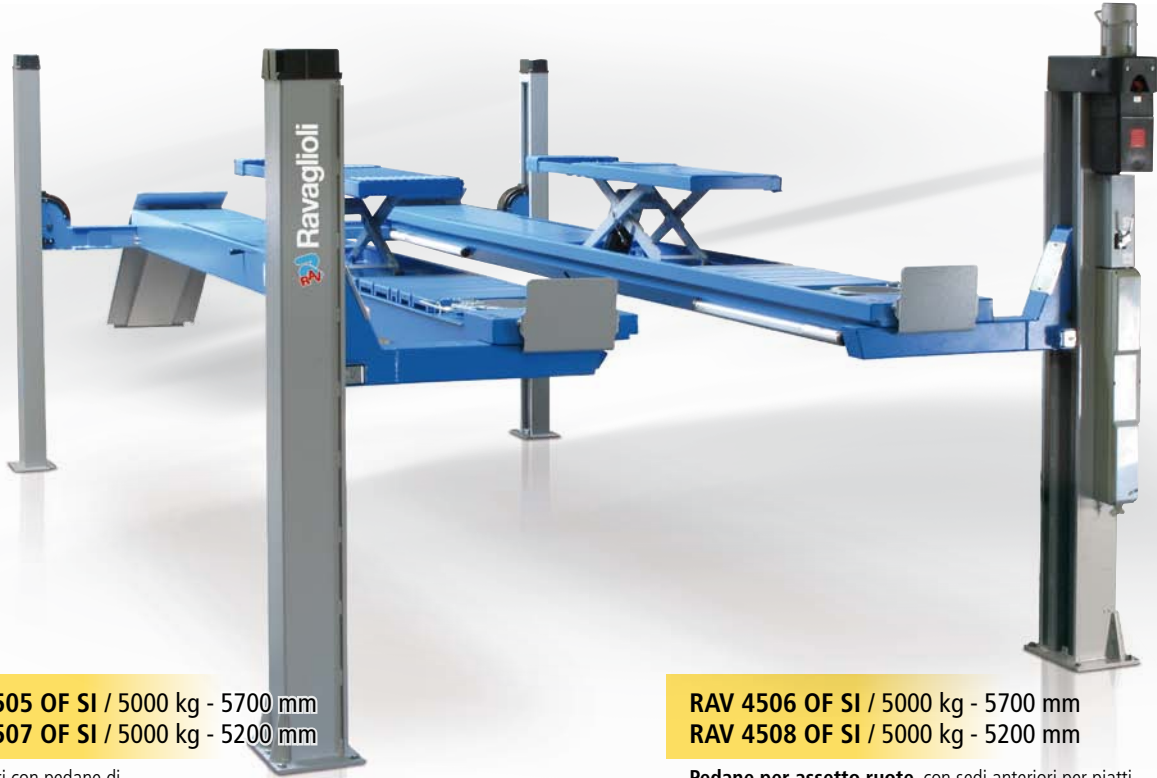

RAV 4505 OF SI / 5000 kg - 5700 mm
RAV 4507 OF SI / 5000 kg - 5200 mm

Sollevatori con pedane di grandi dimensioni e struttura portante studiata per la massima rigidità e stabilità in esercizio.

Lifts with large size platforms and sturdy structure assuring maximum rigidity and working stability.

Hebebühnen mit grossdimensionierten Fahrschienen und für hervorragende Steifigkeit und Betriebsstabilität konstruierte Tragstruktur.

Ponts élévateurs avec chemins de roulement de grandes dimensions et structure portante étudiée pour offrir un maximum de rigidité et de stabilité pendant le fonctionnement.

Elevadores con plataformas de grandes dimensiones y estructura portante estudiada para garantizar la máxima rigidez y estabilidad de trabajo.

RAV 4506 OF SI / 5000 kg - 5700 mm
RAV 4508 OF SI / 5000 kg - 5200 mm

Pedane per assetto ruote, con sedi anteriori per piatt rotanti e piani oscillanti posteriori.

Platforms for total wheel alignment, with front turning plates recesses and rear slip plates.

Fahrschienen für die Achsvermessung, vorne mit Sitzen für Drehteller und hinten mit Schiebepplatten.

Chemins de roulement pour géométrie, avec logements avant pour plateaux pivotants et plans mobiles arrière.

Plataformas para alineación, con asientos para platos giratorios delanteros y platos oscilantes traseros

LIFT TABLE



OPEN FRONT

Accesso totale alla zona di lavoro

Full access to the working area

Komplett freier Zugang im Arbeitsbereich

Accès complètement libre à la zone de travail

Acceso total al área de trabajo

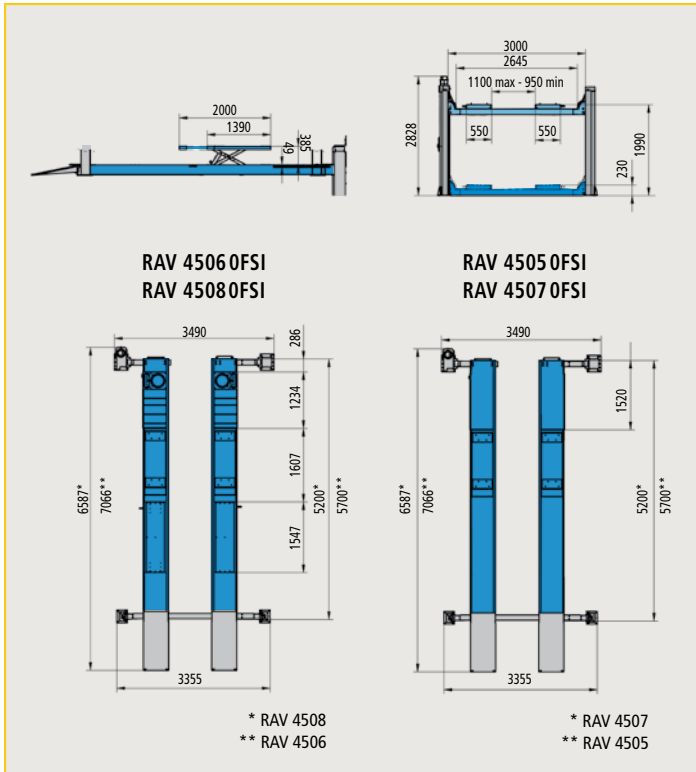

Selettore per sollevamento ponte principale o sollevatore integrato.
 Switch to operate main lift of wheel free lift
 Schalthebel für Haupthebebühne bzw. Radfreiheber.
 Selecteur pour actionnement du pont ou du levage auxiliaire
 Selector para elevación del elevador principal o de la doble elevación

Pulsante di salita
 Lifting button
 Hebeknopf
 Commande de montée
 Pulsador de subida

Pulsante di discesa
 Lowering button
 Senkknopf
 Commande de descente
 Pulsador de bajada

Interruttore generale
 Main switch
 Hauptschalter
 Interrupteur principal
 Interruptor general

Pulsante di parcheggio per assetto ruote
 Parking button for wheel alignment
 Parkknopf für Achsmessstellung

Commande de positionnement sur crémaillère pour contrôle de géométrie

Pulsador de parking para alineado de ruedas (RAV4506OFSI - RAV4508OFSI)

Struttura rinforzata
 Extra strength structure
 Sehr robuste Struktur
 Structure renforcée
 Estructura reforzada



MULTI - POSITION (RAV 4506 OF SI - RAV 4508 OF SI)



OPTIONS

S505A1 (4 x kit)	H= 200 mm				Rampe extralunghe Long run up ramps Lange Auffahrampen Rampes longues Rampas larga
S505A5 S505A6 S505A7 (4 x kit)	H= 120 mm H= 40 mm H= 20 mm		S505A2 (2 x kit) Traverse / Cross members Querstreben / Traverses / Traviesas		Impianto di illuminazione Lighting kit Beleuchtung Système d'éclairage Instalación de alumbrado



Ravaglioli S.p.A.
 via 1° maggio 3
 Fraz. Pontecchio M.
 40037 Sasso Marconi (Bo) - Italia
 Tel. +39 - 051 - 6781511
 Fax +39 - 051 - 846349
 rav@ravaglioli.com
 www.ravaglioli.com

RAV France
 6, Rue Longue Raie
 ZAC de la Fremblaie
 91220 Le Plessis Pâté
 Tel. 01.60.86.88.16
 Fax 01.60.86.82.04
 rav@ravfrance.fr

Ravaglioli Deutschland
 Kirchenpoint 22
 85354 Freising
 Tel. 08165-646956
 Fax 08165-646958
 info@ravaglioli.de

RAV Equipment UK LTD
 Prince Albert House
 20 King Street
 Maidenhead, SL6 1DT
 Tel. 020-76286832
 Fax 020-76286833
 ravuk@ravaglioli.com

RAV en Belgique
 Nederlandstalig
 Tel. 0498-162016
 Fax 016-781025
 Zone Francophone
 Tel. 0498-163016
 Fax +32 78 055 030

RAV Equipos España
 Avenida Europa 17
 Pol. Ind. de Constanti
 Tarragona 43120
 Tel. 977 524525
 Fax 977 524532
 ravequipos@ravaglioli.e.telefonica.net

DRD23U (1)

