

Accessori a richiesta

Optional accessories – Accessoires en option – Accesorios opcionales – Optionales Zubehör

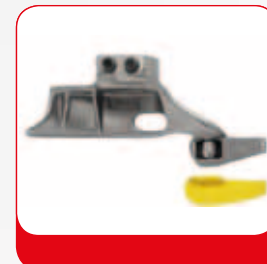

Protezione frontale torretta
Front M/D head protection
Protection frontale tête de montage
Protección frontal de la cabeza
Frontschutz Montagekopf



Tecnarm



Protezione ala torretta
Rear M/D head protection
Protection arrière tête de montage
Protección posterior de la cabeza
Hinterschutz Montagekopf



Helper Group



X 4

Kit 4 pezzi protezione corsia
Slide guard kit (4 pcs)
Kit 4 pièces protection griffes
Kit nr. 4 protecciones garras
Kit 4 Stk. Schutz für Spannklauen



Tecnohelp



Protezione paletta
Bead breaker blade protection
Protection pale
Protección paleta
Schutz für Abdrückschaufel



Helper Arm



Protezione leva
Lever protection
Protection levier
Protección palanca
Schutz für Montiereisen



Crab99
Sollievatore ruota
Wheel lift
Élévateur de roue
Elevador rueda
Radlift



Kit IT Tubeless



Kit rulliera
Roller board
Kit rouleau
Kit rodillo
Rollbrett



Kit scooter

X 4



Kit moto

X 4



Torretta in plastica
Plastic M/D tool
Tête de montage en plastique
Cabeza en plastico
Kunststoffmontagekopf



Kit attacco rapido
Quick change M/D tool
Kit tête de montage rapide
Kit cambio rapido cabeza
Schnellverschluss-Satz für Montagekopf



Leva Run Flat
Run Flat lever
Levier Run Flat
Palanca Run Flat
Run Flat Montiereisen



Pinza Run Flat
Run Flat clamp
Pince Run Flat
Pinza Run Flat
Run-Flat Spannbacke

Dotazione standard Standard supply – Fourniture standard – Dotación estándar – Standardausstattung

Standard / S



PG / PGS / IT / IT S



Dati tecnici Technical data – Données techniques – Datos técnicos – Technische Daten

	KG	IN	OUT	W	D	ALL TYRES				KW	bar	
TC522 IT S	238 Kg								MI 230/1/50-60	10 - 17 rpm	0,75	
TC522 PG S	220 Kg								MI 110/1/60			
TC522 S	220 Kg	10" - 28"	12" - 28"	3" - 16"	1160mm - 46"	✓	2500 Kg		400/3 - 2V	7 - 14 rpm	0,9 - 1,2	8 - 12
TC522 IT	245 Kg								230/3 - 2V			
TC522 PG	226 Kg								230/1/50-60	8 rpm	1,1	
TC522	226 Kg								110/1/60		0,75	

	KG	IN	OUT	W	D	ALL TYRES				KW	bar	
TC52 IT	245 Kg								MI 230/1/50-60	10 - 17 rpm	0,75	
TC528 PG	226 Kg								MI 110/1/60			
TC528	226 Kg	10" - 28"	12" - 28"	3" - 16"	1160mm - 46"	✓	2500 Kg		400/3 - 2V	7 - 14 rpm	0,9 - 1,2	8 - 12
									230/3 - 2V			
									230/1/50-60	8 rpm	1,1	
									110/1/60		0,75	

Ingombri macchina Maximum overall dimensions – Dimensions d'encombrement – Dimensiones máquina – Maschinenabmessungen

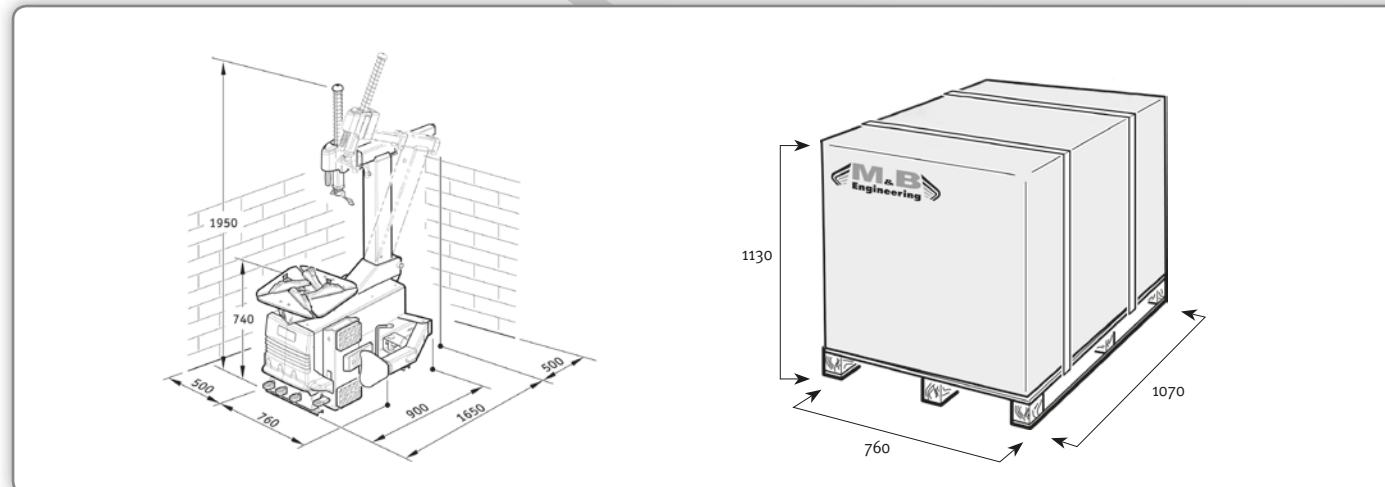

IT0802000001747

Made in Correggio

ITALY

M&B Engineering srl - Via della Costituzione, 49 - 42015 Correggio (RE) - Tel. +39 0522 644511 - Fax +39 0522 644512
www.mbenengineering.info / info@mb-re.it

Dichiaro di riservare il diritto di modificare le caratteristiche dei prodotti in qualsiasi momento. - The manufacturer reserves the right to modify the technical specifications of its products at any time. - La société se réserve le droit de modifier les caractéristiques de ses produits à tout moment. - La empresa se reserva el derecho de modificar las características de sus productos en cualquier momento. - Der Hersteller behält sich das Recht vor, die Eigenschaften der Produkte jederzeit zu ändern.

COD. 20463

TC522



Tested according to walk-Mounting Demounting Instructions UNP and Run Flat Tyres



TC528 IT

